

Product Information

Pull-force measurement system

POWER-CHECK II

ENGLISH

95.100.352.D.E / 2010-02

OTT-JAKOB
Spanntechnik GmbH
Industriestraße 3 – 7
D - 87663 Lengenwang

☎ +49 (0) 83 64 / 98 21 -0
📠 +49 (0) 83 64 / 98 21 -10
✉ info@ott-jakob.de
<http://www.ott-jakob.de>

JAKOB
GRUPPE

Table of contents

1	Safety notes.....	5
1.1	Intended use.....	5
2	Product Description.....	6
2.1	Function.....	6
2.2	Dimensions.....	7
2.3	Features.....	7
2.3.1	Force measuring	8
2.4	Technical Data.....	8
2.5	Order numbers.....	9
2.5.1	Basic unit.....	9
2.5.2	Adapter for HSK / manual operation.....	9
2.5.3	Adapter for Capto / manual operation.....	9
2.5.4	Adapter for steep taper / manual operation.....	10
2.5.5	Adapter for hollow shaft with gripper groove for automatic tool change.	10
2.5.6	Adapter for steep taper with gripper groove for automatic tool change.....	10
3	Assembly of adapter.....	11
3.1	Preparation.....	11
3.2	Assembly	11
4	Start-up.....	13
4.1	Adjustment of the adjustable range	13
4.2	Prepare charging process	14
4.3	Load battery	14
5	Operation	15
5.1	Manual operation.....	15
5.2	Automatic operation	16
5.3	Continuous measuring mode	17
5.3.1	Continuous measuring mode.....	17
5.4	Measured values	18
5.4.1	Display measured values	18
5.4.2	Measured value memory.....	19
5.5	Battery state of charge	19

6	System settings	20
7	Maintenance	22
7.1	Deactivation in the event of failures.....	22
7.2	Maintenance.....	22
7.3	Deactivation	22
8	PC software	23
8.1	Product description.....	23
8.2	Installation.....	23
8.3	Operation.....	24
8.3.1	Start-up.....	24
8.3.2	Display and operation.....	24
8.4	Charging process	26

symbol explanation:



keep attention - dangerous



keep attention - malfunction

Case contents:

- Pull-force measurement system (Base unit)
- tool
- PC software with driver CD
- USB connection cable
- Product Information Pull-force measurement system **Power-Check II**
- Quick guide

EC Declaration of Conformity

It is hereby declared that this product complied with the essential protection requirements of Council Directive 89/336/EEC and its amendments on the approximation of the laws of the Member States relating to electromagnetic compatibility.

This declaration applies to all specimens manufactured identical to the model submitted for testing/evaluation.

Directive	Standard / Reference number	Edition
2004/108/EC	EN 61326-1	Mai 2004
2004/108/EC	EN 61010-1	August 2002

WEEE Notice

The Directive on Waste Electrical and Electronic Equipment (WEEE), which entered into force as European law on 13th February 2003, resulted in a major change in the treatment of electrical equipment at end-of-life.

The WEEE logo (shown at the left) on the product or on its box indicates that this product must not be disposed of or dumped with your other household waste.

For more information about electronic and electrical waste equipment disposal, recovery, and collection points, please contact your local municipal household waste disposal service or shop from where you purchased the equipment.

RoHS Compliance

This product is in compliance with Directive 2002/95/EC of the European Parliament and of the Council of 27 January 2003, on the restriction of the use of certain hazardous substances in electrical and electronic equipment (RoHS) and its amendments.

FCC Compliance

This equipment has been tested and found to comply with the limits for a Class B digital device, pursuant to Part 15 of the FCC Rules. These limits are designed to provide reasonable protection against harmful interference in a residential installation. This equipment generates, uses and can radiate radio frequency energy and, if not installed and used in accordance with the instructions, may cause harmful interference to radio communications. However, there is no guarantee that interference will not occur in a particular installation. If this equipment does cause harmful interference to radio or television reception, which can be determined by turning the equipment off and on, the user is encouraged to try to correct the interference by one or more of the following measures:

- Reorient or relocate the receiving antenna.
- Increase the separation between the equipment and receiver.
- Connect the equipment into an outlet on a circuit different from that to which the receiver is connected.
- Consult the dealer or an experienced radio/TV technician for help.



1 Safety notes

Consider always the following points:



Important

- Follow the operating instructions
- Avoid impacts and vibrations to the system
- The system may be operated only within the specified technical values and limits.
- Commissioning, adjustments and operation is allowed only by qualified personnel.
- In the cases of improper system adjustment or use, the OTT-JAKOB company will not accept any liability.

1.1 Intended use

The pull-force measurement system has been designed for an industrial environment. It measures the pull-force in the power drawbar.

The measured pull-force can be read from the display during manual operation. In addition, the measured value will be stored.

During automatic operation, the measured value is stored internally for use during the automatic tool change.

The measured value can be logged using the **POWER-CHECK II** - PC-Software (USB interface)

2 Product Description

2.1 Function

The pull-force measurement system **POWER-CHECK II** measures the pull-force in power drawbars.

The exchangeable adapter allows the use with steep taper and HSK systems.

The pull-force measurement system is embedded in the tool holder. The force occurring after the clamping process is logged by the measurement system.

The measured pull-force is read from the display during manual operation. In addition, the measured value is stored internally and may be logged by an adequate reading device (USB interface).

During automatic operation, the use from a tool magazine is possible. If the measurement device is automatically transported into the clamping unit, the internal motion detector switches the device from the standby into the operational mode. This ensures a long battery life. The measured pull-force is stored internally and can be logged with an adequate reading device (USB interface).

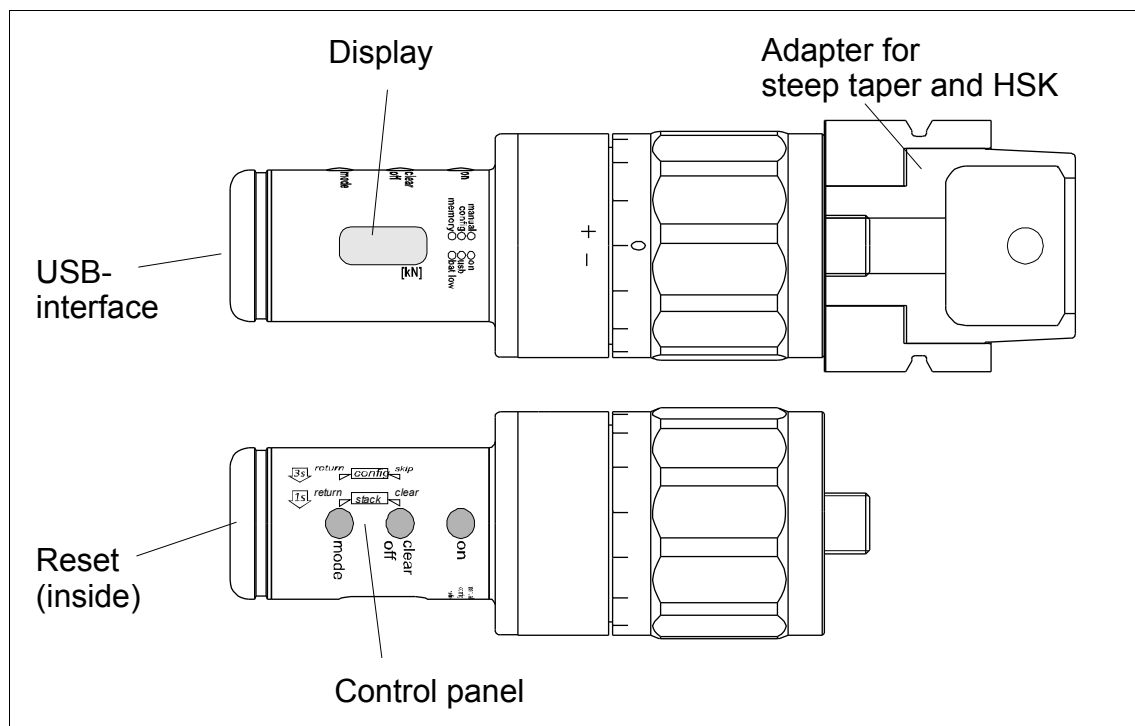

2.3.1 Force measuring

Force measuring within the tolerancefield of spindle and tool possible

Common powercheck gages measure only the nominal dimensions of the taper.

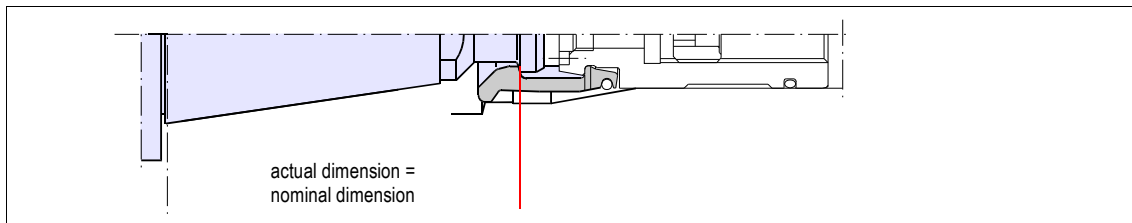

If the part dimensions deviate, the measured value would be wrong.

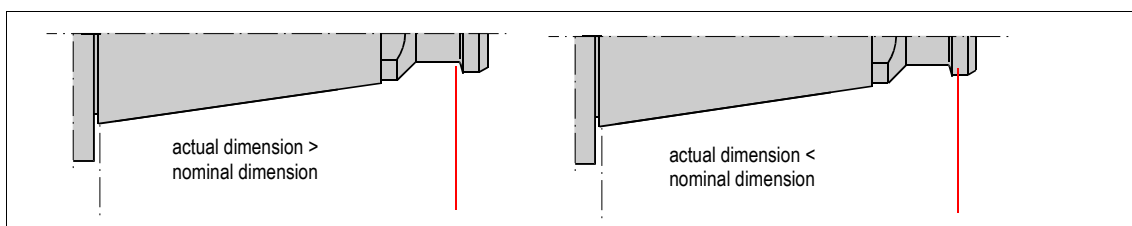

The **POWER-CHECK** offers the possibility to take those tolerances in its consideration.

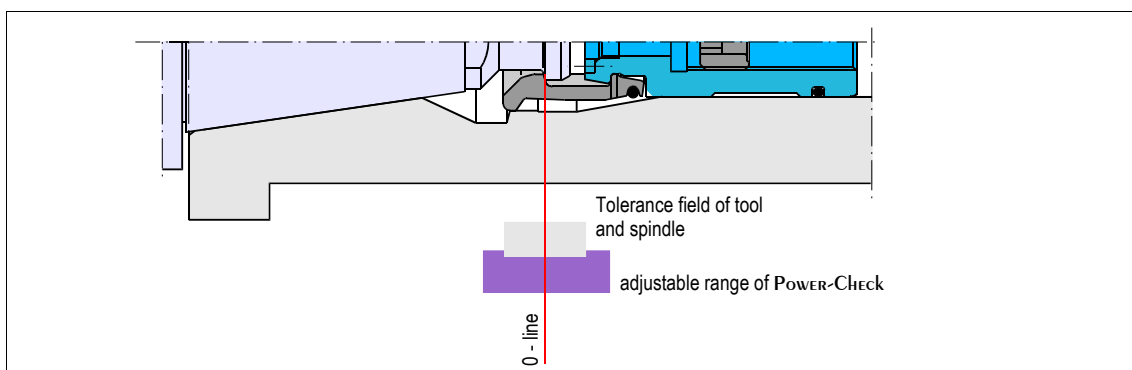

2.4 Technical Data

Measuring range	0,14 - 5 / 0,4 - 15 / 2 - 75 / 5,5 - 200 [kN]
Temperature range	+15 °C to + 35 °C
Measuring system	Straingage
Charging process	via USB interface
Weight	max. 1,5 kg

2.5 Order numbers

2.5.1 Basic unit

Measuring range	Order number
0,14 - 5 kN	95.103.134.9.2
0,4 - 15 kN	95.103.135.9.2
2 - 75 kN	95.103.136.9.2

2.5.2 Adapter for HSK / manual operation

Nominal size	Order number
E 25 / F 32	95.600.069.9.2
A 32 / B 40	95.600.070.9.2
A 40 / B 50	95.600.071.9.2
A 50 / B 63	95.600.072.9.2
A 63 / B 80	95.600.073.9.2
A 80 / B 100	95.600.074.9.2
A 100 / B 125	95.600.075.9.2
A 125 / B 160	95.600.076.9.2

2.5.3 Adapter for Capto / manual operation

Nominal size	Order number
C4 ISO 26623-1	95.601.481.9.2
C5 ISO 26623-1	95.601.482.9.2
C6 ISO 26623-1	95.601.266.9.2
C8 ISO 26623-1	95.601.483.9.2

2.5.4 Adapter for steep taper / manual operation

Nominal size	DIN 69871 / 69872 ISO 7388 / 1 / 2 Typ A	ANSI B 5.50-78 ISO 7388 / 1 / 2 Typ B	MAS 403-1982 BT / PT-I (45°)	MAS 403-1982 BT / PT-II (30°)
SK 30	95.101.582.9.2	95.101.583.9.2	95.101.584.9.2	95.101.585.9.2
SK 40	95.101.586.9.2	95.101.587.9.2	95.101.588.9.2	95.101.589.9.2
SK 45	95.101.590.9.2	95.101.591.9.2	95.101.592.9.2	95.101.593.9.2
SK 50	95.101.594.9.2	95.101.595.9.2	95.101.596.9.2	95.101.597.9.2
SK 60	95.101.598.9.2	95.101.599.9.2	95.101.601.9.2	95.101.602.9.2

2.5.5 Adapter for hollow shaft with gripper groove for automatic tool change.

Nominal size	Order number
A 63 / B 80	95.601.851.9.2

2.5.6 Adapter for steep taper with gripper groove for automatic tool change.

Nominal size	DIN 69871 / 69872 ISO 7388 / 1 / 2 Typ A
SK 50	95.103.097.9.2

Other adapters available on request!

3 Assembly of adapter

3.1 Preparation



The contact surfaces of the basic unit and the adapter must be clean and undamaged.

3.2 Assembly

HSK to nominal size A 63/B 80

and

Capto up to C6

➤ Screw on pull stud and tighten	➤ Secure pull stud	➤ Attach compression ring; secured by a spring loaded ball

HSK over nominal size A 80/B 100

and

Capto C8

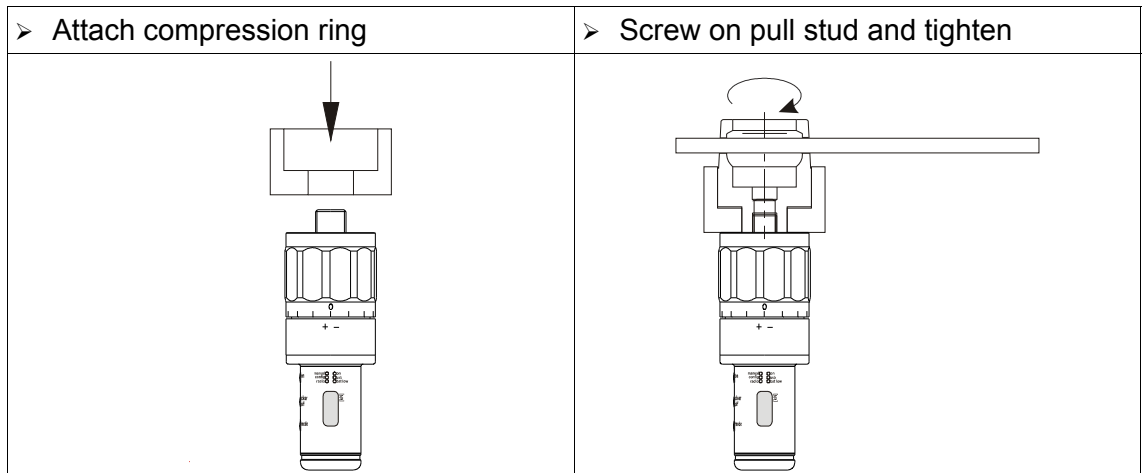

Steep taper

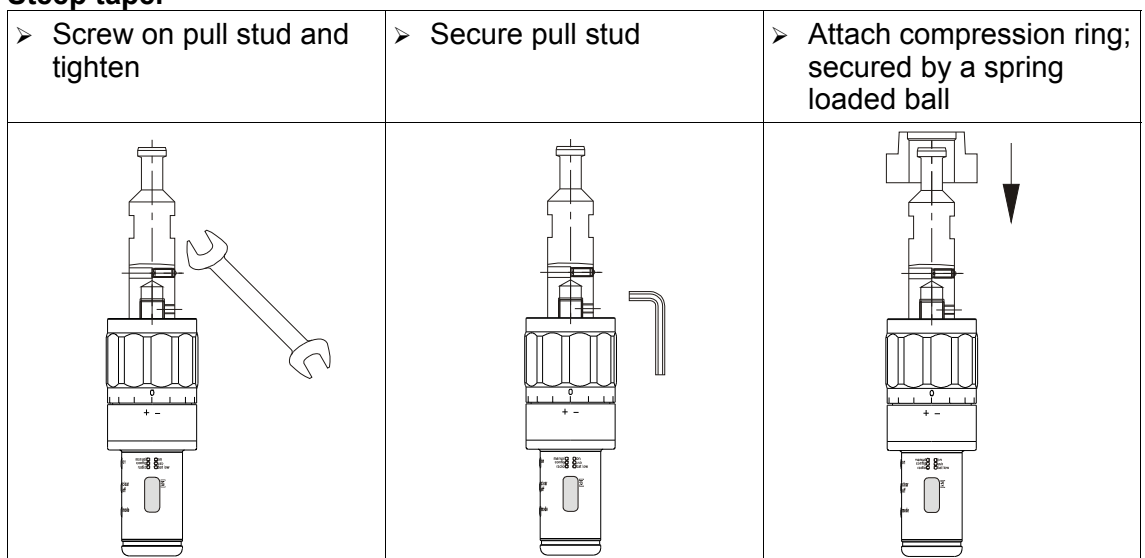

Note:

The pull force measurement system is protected against spray water if the base unit is used in conjunction with a OTT-JAKOB adapter with gripper groove.

4 Start-up



The **POWER-CHECK** is a precision instrument → Please handle with care!

Measuring conditions: the following requirements must definitely be fulfilled in order to get accurate measurements

- Measuring range (see technical data)
- Temperature range (see technical data)
- use suitable adapter, observe the proper steep taper standard!

4.1 Adjustment of the adjustable range



Adjusting the adjustable range (sleeve position) is possible in a released condition only!

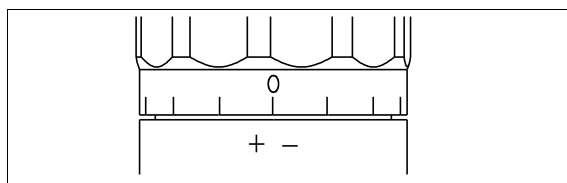

- Screw in adjustable sleeve delicately to the shoulder
- Turn back adjustable sleeve after it passed the 0-mark the first time

The **POWER-CHECK** with the adapter now is set to the medium tolerance field of the corresponding tool standard

Turning the adjustable sleeve toward "+" makes the adapter longer, turning it toward "-" makes the adapter shorter

The permissible adjusting range is:

for **HSK** according to DIN 69893 and **Capto**

- +/- 0.1mm is +/- 1 index on the adjustable sleeve

for **steep taper** per ISO 7388 type A and B
DIN 2080
MAS 403

- +/- 0.3mm is +/- 3 indexing on the adjustable sleeve

The adjustable sleeve must be always engaged!

4.2 Prepare charging process

The **POWER-CHECK II** is powered via a USB PC interface.

A driver installation is required.

The driver is supplied on an enclosed data medium. Installation is performed via an exe.-file.

System requirements::

- USB interface
- Windows operating system
- CD drive (for driver installation)

Note: do not use a USB charger!

4.3 Load battery

The battery condition is briefly displayed during power on (Line display 0 - 100%).

For charging

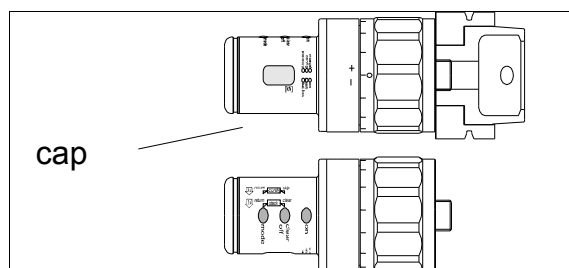

- Remove cap
- Connect USB connector with the PC

Charging process

- Charge 75 %: max. 4 h (the device's charge indicator already indicates this charge state at 100%)
- Charge 100 %: < 10 h
- Charging process may be interrupted at any time
- Charging switches off automatically

5 Operation

5.1 Manual operation

The measured pull-force is read from the display during manual operation. In addition, the measured value is stored internally and may be logged by an adequate reading device (USB interface).

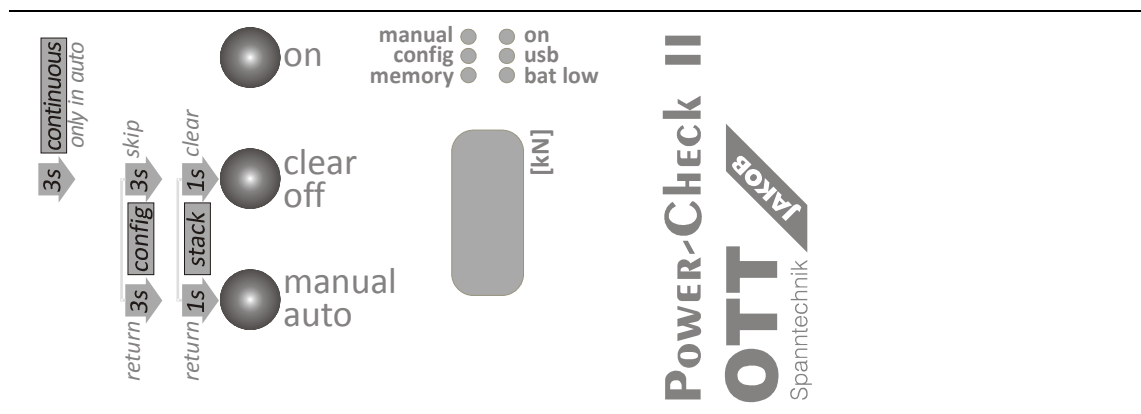

Activate



The battery charging condition is briefly display (line display 0 - 100%); the device is operational thereafter

Measuring

- Clamp tool
- Read pull-force

Pull-force is displayed
 Drag indicator display: only the maximum value is displayed and remains displayed until the *clear* button is pushed
 Adjusting the adjustable range (sleeve position) is possible in a released condition only(→ 4.1 / 13)

Storing



The current data is stored every time *clear* is pushed. The LED *memory* lights up briefly
 Many thousand measurements can be stored.
 Stored data: consecutive number, ID, date, time, measured value [kN], sleeve position (adjustable range for tolerances)

Deactivate

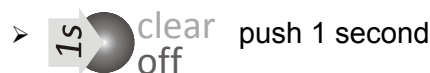

Otherwise, the power-off function automatically deactivates the measurement tool after 2 minutes.

5.2 Automatic operation

In automatic operation, the measured pull-force is stored internally and can be logged with an adequate reading device (USB interface).

During automatic operation, application from a tool magazine is possible.

Spindle rotation with the measuring device is not allowed!



Important

Activate



The battery charging condition is briefly display (line display 0 - 100%); the device is operational thereafter

change to automatic operation



LED flashes *on*

The measurement tool switches from standby to operation automatically as soon as it is moved. It checks for a measurable force and stores it if applicable. If there is no measurable force applied, the device switches back to standby after a pre-defined time.

Many thousand measurements can be stored and logged with an adequate reading device (USB interface).

change to manual mode



LED *on* and *manual* light up

Deactivate



Possible only in manual mode!

5.3 Continuous measuring mode

In continuous measuring mode, it is possible to perform a defined number of measurements with a defined time interval.

Factory setup is 10 measurements with a 0.5 second time interval: The total measuring series lasts $(10-1) \times 0.5 = 4.5$ seconds.

The number and time interval may be adjusted using the **POWER-CHECK II** - PC software (USB interface).

Activate



change to automatic operation



5.3.1

Continuous measuring mode



push *clear* until - - - is displayed

Recording of the measuring series starts immediately.

Manual operation is subsequently activated.

5.4 Measured values

5.4.1 Display measured values

It is possible to display the last measurements directly on the system. These measurements are compiled in a stack. In order to access this function on an activated device, do the following:

Stack mode

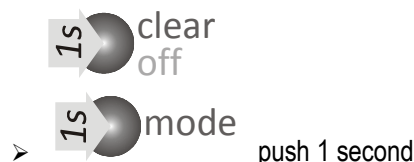

The following information is displayed: stack number (n01), ID (i05), measured value [kN] (18.6) in temporal sequence.

The stack number is not identical with the consecutive measured value number! Stack number one always represents the number of the last measurement.

An example:

Stack number	Consecutive number
001	255
002	254
003	253
004	252
005	251

A maximum of 20 of the most recent measurements are displayed. Older measured values are deleted.

Leave stack mode



Delete stack

- If the stack should be deleted completely: change into the stack mode, push *clear* until - - - appears

The stack has been deleted. No measured values can be accessed directly on the measuring device. But all measured values remains stored.

5.4.2 Measured value memory

The measured pull-force is stored internally and can be logged with an adequate reading device (USB interface). Handling is described in a separate document.

Many thousand measurements can be stored.

The display message *ful* indicates that the measured value memory is at 100% capacity. Additional measured values will overwrite the first measured values!

5.5 Battery state of charge

The battery condition is briefly displayed during power on (Line display 0 - 100%).

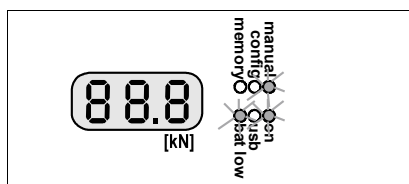

If the LED **bat low** (battery low) lights up, the measurement system has to be recharged at the USB interface as soon as possible.
→ 4.2 and 4.3

6 System settings

The **POWER-CHECK II** allows to change the following settings:

- Identification number ID
- Activation threshold value for the motion detector (in automatic operation)
- Measuring duration in automatic mode
- Display brightness

Follow the following steps for changing values:

Select configuration menu

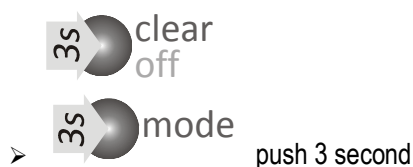

StA and then con: release buttons
LED *config* lights up

It is possible to adjust various values in the configuration menu. The same pattern applies to every setting:

increase value



decrease value

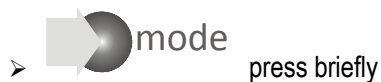



next setting in configuration menu



The following values can be adjusted:

Identification number ID	<p>Id and shortly thereafter the identification number are displayed</p> <p>An identification number may be entered here, e.g. when various clamping systems are measured.</p>
Motion sensor threshold value	<p>Int (for interrupt) is briefly displayed; shortly thereafter followed by a value between 0 and 255.</p> <p>This value indicates the motion sensor threshold value: small value indicates that low accelerations are needed to trigger; high value indicates that high accelerations are required; ; our recommendation: ~ 40.</p> <p>Change threshold values: see above</p>
Measuring duration in automatic mode	<p>dur (duration) is briefly display; shortly thereafter followed by a value.</p> <p>This value indicates the duration during which the measured values are recorded in automatic mode. The maximum value of these measured values will then be logged.</p> <p>Example: ~ 10 (approx. 5 seconds)</p>
Display brightness	<p>bri (for brightness) is briefly displayed; shortly thereafter followed by a value between 0 and 255.</p> <p>This value indicates the screen brightness. a small value indicates a dark screen (low power consumption); high value - bright (high power consumption); our recommendation: ~ 130 - 200</p>

Press *clear* again to return to the *id* loop. (loop).

Exit configuration menu   **mode** For exiting the configuration menu:
push *mode* until the display changes to manual mode

7 Maintenance

7.1 Deactivation in the event of failures

The device can be forced to deactivate in the event of failures. For this:

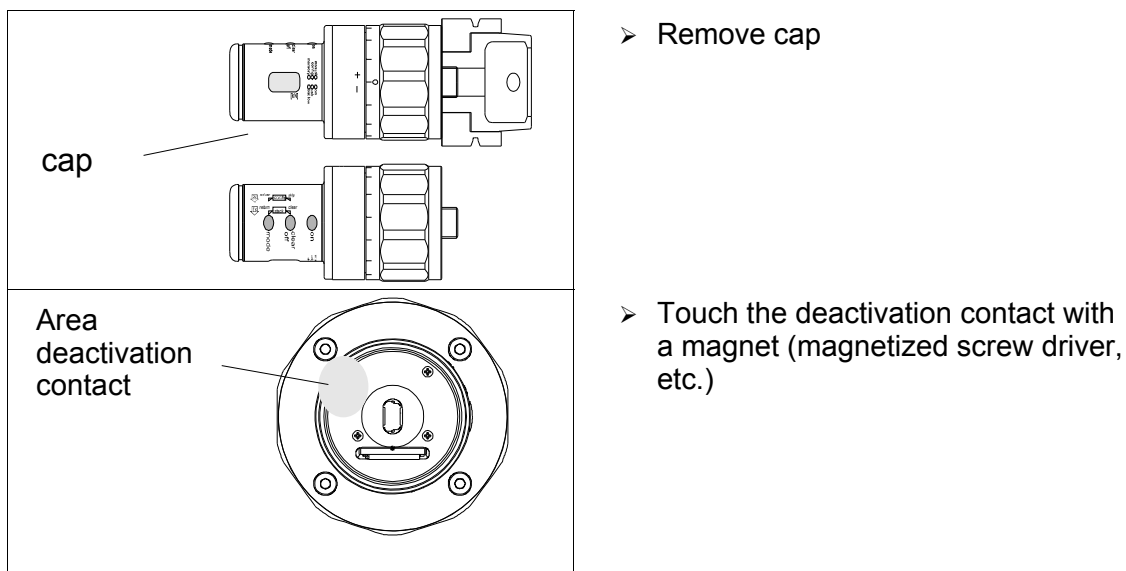

➤ Remove cap

➤ Touch the deactivation contact with a magnet (magnetized screw driver, etc.)

The system is now deactivated can be switched back on. The stored measured values remain preserved.

7.2 Maintenance

Inspection by OTT-JAKOB

- yearly
- after a fall or a similar incident

7.3 Deactivation

After deactivation, proper battery disposal requires the measuring unit to be shipped to OTT-JAKOB.

8 PC software

8.1 Product description

The software contains the driver for charging the pull force measurement system **POWER-CHECK II** battery.

The software allows adjusting system parameters and reading and exporting measured values stored in the system.

8.2 Installation

System requirements:

- USB interface
- Windows operating system
- CD drive for installation

The measuring system must not be connected during installation!

- Insert CD
- Start .exe file

Installation begins, the following information is requested:

- Language
- Program storage location

Installation is closed after accepting the license agreement.

Note for uninstallation: Program may be uninstalled using the supplied program „Power-Check II_remove“.

8.3 Operation

8.3.1 Start-up

- Connect **POWER-CHECK II** to the active PC via the supplied USB connection cable.
- Wait for system recognition by the operating system
- Start program **POWER-CHECK II** PC software; the following should be displayed in the connection display: *1 device(s) found and 1 connected*

Observing the sequence is essential!

8.3.2 Display and operation

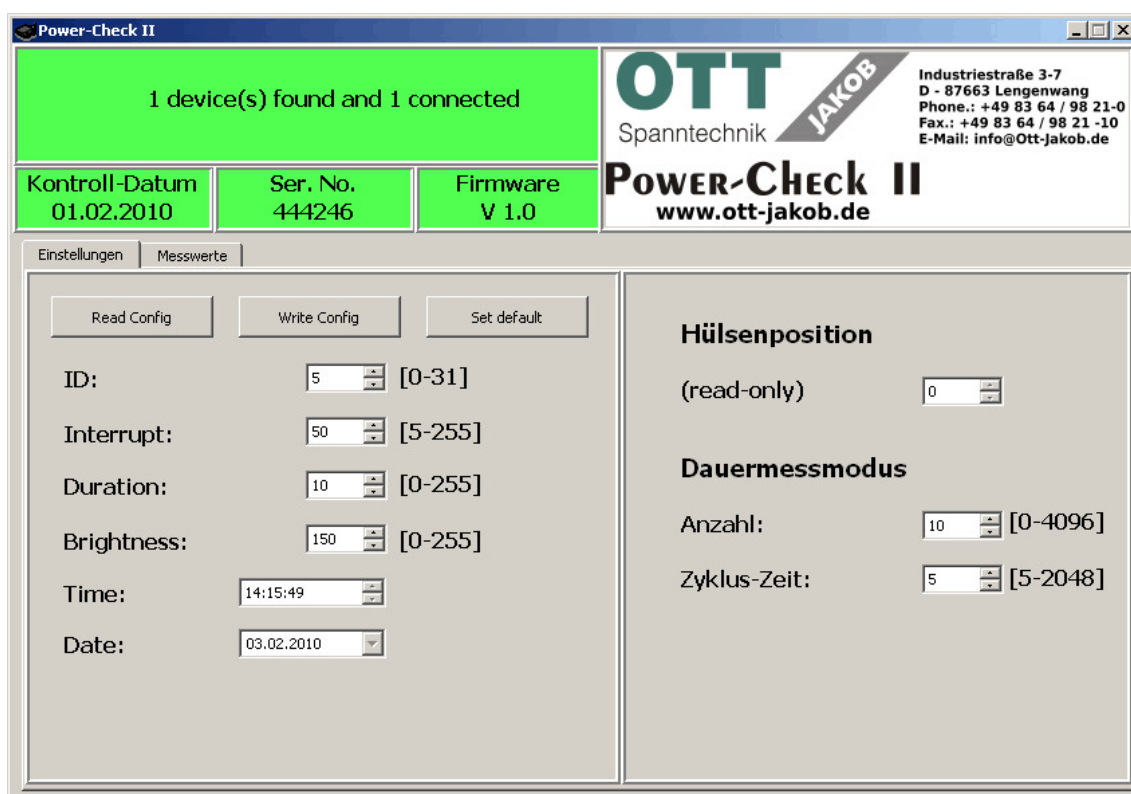

Display area

The green display area indicates displays the following information:

- Connection: successful when *1 device(s) found and 1 connected* appears
- Inspection date: date of OTT-JAKOB outgoing inspection (regular inspection)
- System serial number
- Firmware version number

Category settings:

- **Read Config:** Pressing this button reads the current measuring system settings; these settings are displayed during startup as described above
- **Write Config:** Pressing this button transfers the program field setting changes to the measuring system, overwriting the previous settings.
- **Set default:** Pressing this button resets all program values to factory default.

System setting for ID, Interrupt, Duration and Brightness: May be altered by pressing the arrow-up-button or arrow-down-button or by adding a value. → 6 / 20

Settings for **time** and **date** are take over from the PC; no possibility to adjust from within the program.

Sleeve position is displayed only, no possibility to adjust from within the program.
→ 4.1 / 13

Continuous measuring mode settings are altered via the same method as the system settings. → 5.3 / 17

Category measured values

The following measured values are displayed here:

- Measurement
- Date
- Time
- Measured value [kN]
- Sleeve position
- Device ID

The current storage space/memory use is displayed in percent next to it.

- **Read memory:** Pressing this button reads the measured values to the PC and displays them on the screen.
- **Export:** Pressing this button saves the current measured values to a folder (requiring selection). Two txt files are created: one file with comma and one ..dot.txt file with a point as decimal separator
The txt files can be imported and analyzed via any standard spreadsheet program.
- **Clear Memory:** Pressing this button irretrievable deletes all measured values in the pull force measuring system!

8.4 Charging process

The PC USB interface supplies the **POWER-CHECK II**, this only works if the software has been installed!

- Connect **POWER-CHECK II** to the active PC via the supplied USB connection cable.

Start the program in order to check the charging process; the following should be displayed in the connection display: *1 device(s) found and 1 connected*