

# OTT

Spanntechnik

JAKOB

## Product Information

**The pull-force measurement  
system**

**Power-Check**

95.100.230.D.E / 98.11

OTT-JAKOB GmbH & Co  
Spanntechnik KG  
Industriestraße 3 - 7  
D-87663 Lengenwang

Phone: (+49) 08364 /98 21 -0  
Fax: (+49) 08364 /98 21 -10  
E-mail: TechDoku@Ott-Jakob.de  
Service: (+49) 08364 /98 21 -59

**JAKOB  
GRUPPE**

## Table of contents

<b>1</b>	<b>Product Description.....</b>	<b>3</b>
1.1	Remarks.....	3
1.1.1	Force measuring within the tolerancefield of spindle and tool possible.....	4
1.2	Technical Data.....	5
1.3	Order numbers.....	5
1.3.1	Basic unit.....	5
1.3.2	Adapter for HSK.....	5
1.3.3	Adapter for steep taper.....	6
<b>2</b>	<b>Assembly of adapter.....</b>	<b>7</b>
2.1	Preparation.....	7
2.2	HSK to nominal size A 63/B 80.....	7
2.3	HSK over nominal size A 80/B 100.....	8
2.4	Steep taper.....	8
<b>3</b>	<b>Measuring.....</b>	<b>9</b>
3.1	Measuring conditions.....	9
3.2	Adjustment of the adjustable range.....	9
3.3	Measuring procedure.....	10
<b>4</b>	<b>Maintenance.....</b>	<b>10</b>
<b>5</b>	<b>Inspections.....</b>	<b>11</b>

# 1 Product Description

Easy and fast measuring of the pull force of all common clamping systems. Using interchangeable adapters, it is possible to measure the pull force on steep tapers as well as on hollow shaft tapers.

## 1.1 Remarks

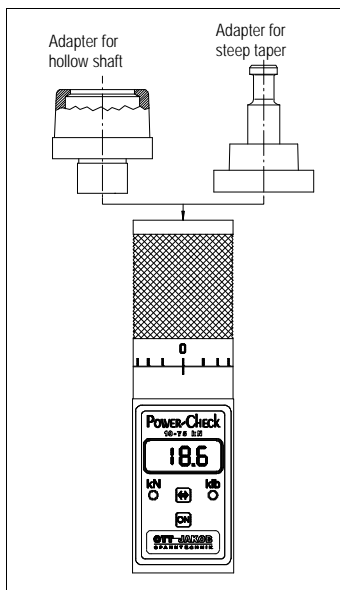

- universal application for all common steep taper and hollow shaft taper standards
- pull force measuring mechanism integrated in base unit
- no power connection required
- auto power off
- display in newton and lbs
- display with maximum value memory

### 1.1.1 Force measuring within the tolerancefield of spindle and tool possible

Common powercheck gages measure only the nominal dimensions of the taper.

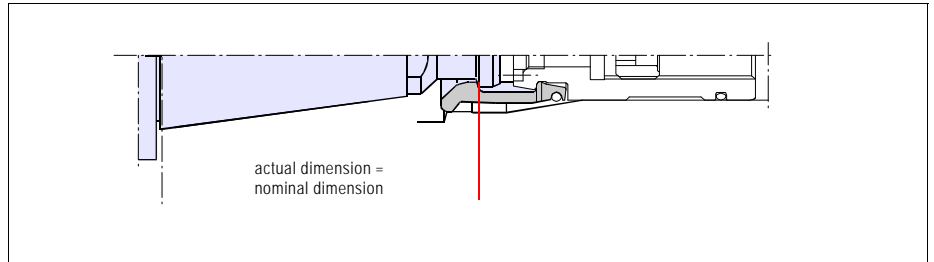

If the part dimensions deviate, the measured value would be wrong.

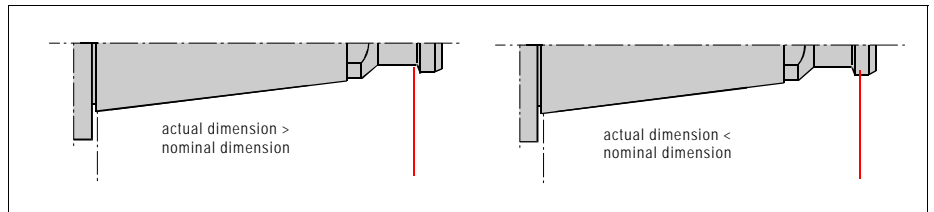

The Power Check offers the possibility to take those tolerances in its consideration.

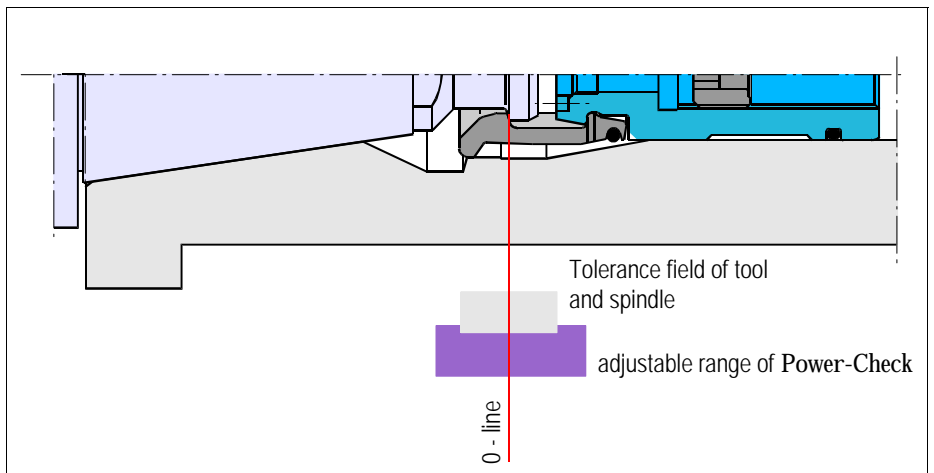

## 1.2 Technical Data

Measuring range	<b>2 - 15 kN</b> and <b>10 - 75 kN</b>
Measuring system	Straingage
Display	big 3.5 digit LCD.-display
Power source	9 volt battery
Weight	max. 6.6 lbs
Temperature range	14 °F to 122 °F

## 1.3 Order numbers

### 1.3.1 Basic unit

Order number	Measuring range
95.101.712.2.2	2 - 15 kN
95.101.600.2.2	10 - 75 kN

### 1.3.2 Adapter for HSK

Nominal size	Order number
E 25 / F 32	95.600.069.9.2
A 32 / B 40	95.600.070.9.2
A 40 / B 50	95.600.071.9.2
A 50 / B 63	95.600.072.9.2
A 63 / B 80	95.600.073.9.2
A 80 / B 100	95.600.074.9.2
A 100 / B 125	95.600.075.9.2
A 125 / B 160	95.600.076.9.2

### 1.3.3 Adapter for steep taper

Nominal size	DIN 69871 / 69872 ISO 7388 / 1 / 2 type A	ANSI B 5.50-78 ISO 7388 / 1 / 2 type B	MAS 403-1982 BT / PT-I (45°)	MAS 403-1982 BT / PT-II (30°)
SK 30	95.101.582.9.2	95.101.583.9.2	95.101.584.9.2	95.101.585.9.2
SK 40	95.101.586.9.2	95.101.587.9.2	95.101.588.9.2	95.101.589.9.2
SK 45	95.101.590.9.2	95.101.591.9.2	95.101.592.9.2	95.101.593.9.2
SK 50	95.101.594.9.2	95.101.595.9.2	95.101.596.9.2	95.101.597.9.2
SK 60	95.101.598.9.2	95.101.599.9.2	95.101.601.9.2	95.101.602.9.2

Other adapters available on request!

## 2 Assembly of adapter

### 2.1 Preparation



The contact surfaces of the basic unit and the adapter must be clean and undamaged.

### 2.2 HSK to nominal size A 63/B 80

„ Screw on pull stud and tighten

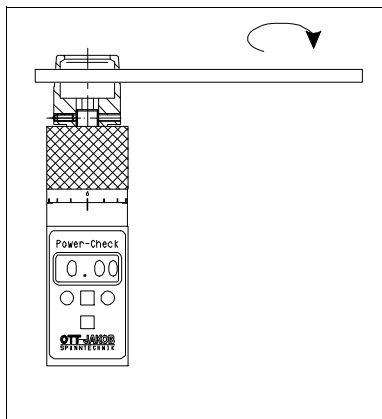

„ Secure pull stud

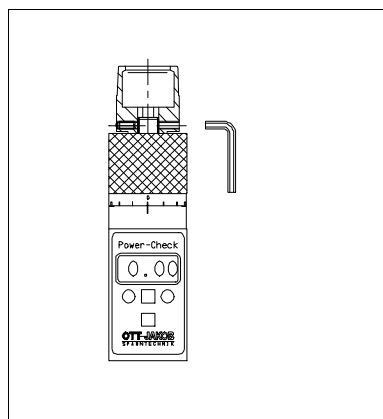

„ Attach compression ring; secured by a spring loaded ball

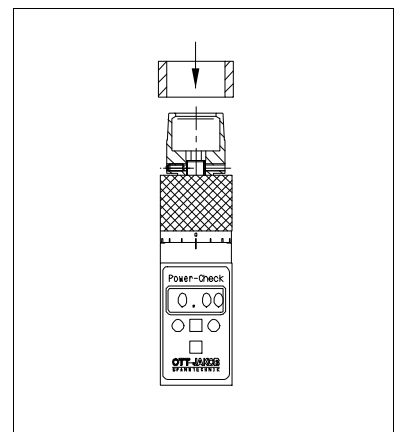

## 2.3 HSK over nominal size A 80/B 100

„ Attach compression ring

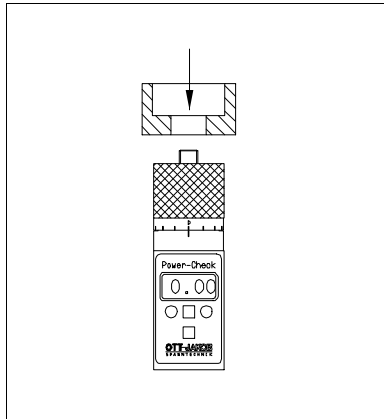

„ Screw on pull stud and tighten

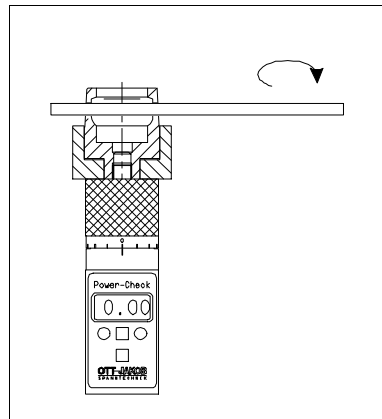

## 2.4 Steep taper

„ Screw on pull stud and tighten

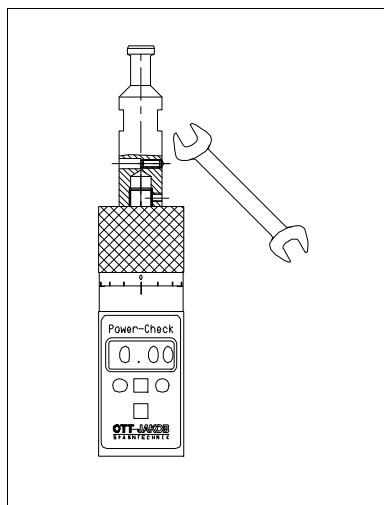

„ Secure pull stud

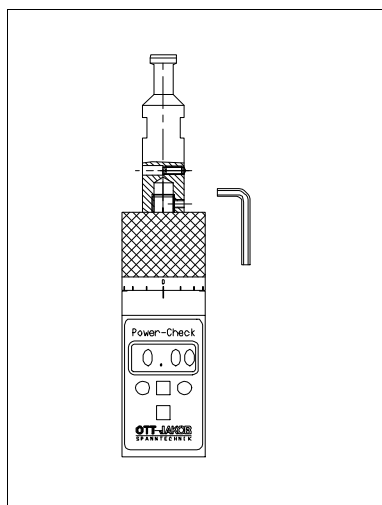

„ Attach compression ring; secured by a spring loaded ball

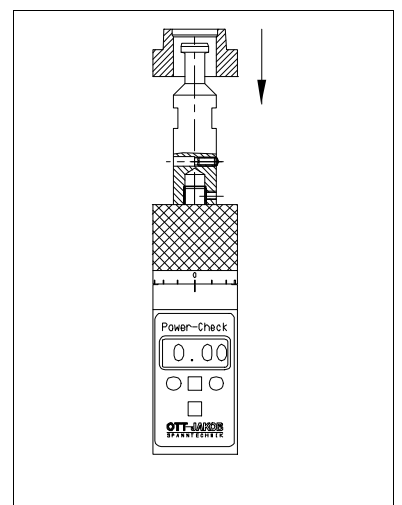

### 3 Measuring

**Wichtig** 

The Power-Check is a precision instrument –  
Please handle with care!

**Wichtig** 

#### 3.1 Measuring conditions

The following requirements must definitely be fulfilled in order to get accurate measurements

- Temperature range within 59 °F and 95 °F
- use only within the proper range of the basic unit; either 2-15 kN or 10 to 75 kN
- use suitable adapter,  
observe the proper steep taper standard!

#### 3.2 Adjustment of the adjustable range

- „ Screw in knurled sleeve delicately to the shoulder
- „ Turn back knurled sleeve after it passed the 0-mark the first time

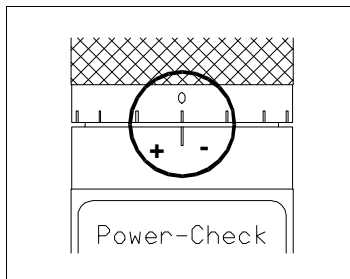

The Power-Check with the adapter now is set to the medium tolerance field of the corresponding tool standard

Turning the knurled sleeve toward "+" makes the adapter longer,  
turning it toward "-" makes the adapter shorter

The permissible adjusting range is:

for **HSK** according to DIN 69893

- +/- 0.1mm is +/- 1 index on the knurled sleeve

for **steep taper** per ISO 7388 type A and B  
DIN 2080  
MAS 403

- +/- 0.3mm is +/- 3 indexing on the knurled sleeve

### 3.3 Measuring procedure

„ Insert Power-Check into the spindle and preload it.



„ Switch on Power-Check

If needed



„ Select measurement unit; display on LED

„ Adjust adjustable range (see above); press ON button again

„ Repeat measuring by pressing ON again

Power-Check turns off automatically!

## 4 Maintenance

When malfunction, remove and reinsert battery

- Change battery if display shows **LOW BAT**
- Have OTT-JAKOB inspect the Power-Check once a year

## 5 Inspections

Serial No. ....

Serial No. of display .....

Serial No. of power sensor .....

### Technical data

Measurement range .....kN

Accuracy class 1 % of maximal value

Nominal temperature 59 °F to 95 °F

actual temperature .....°C

force limit: 130 % of the maximal value

break force > 300 % of the maximal value

### Test protocol

Date	Inspector	Nominal value				
		2-15 kN	4 kN	7 kN	10 kN	15 kN
		10-75 kN	15 kN	20 kN	50 kN	-
Actual value						

