

Unclamp Unit LE 124 F-B

dimension

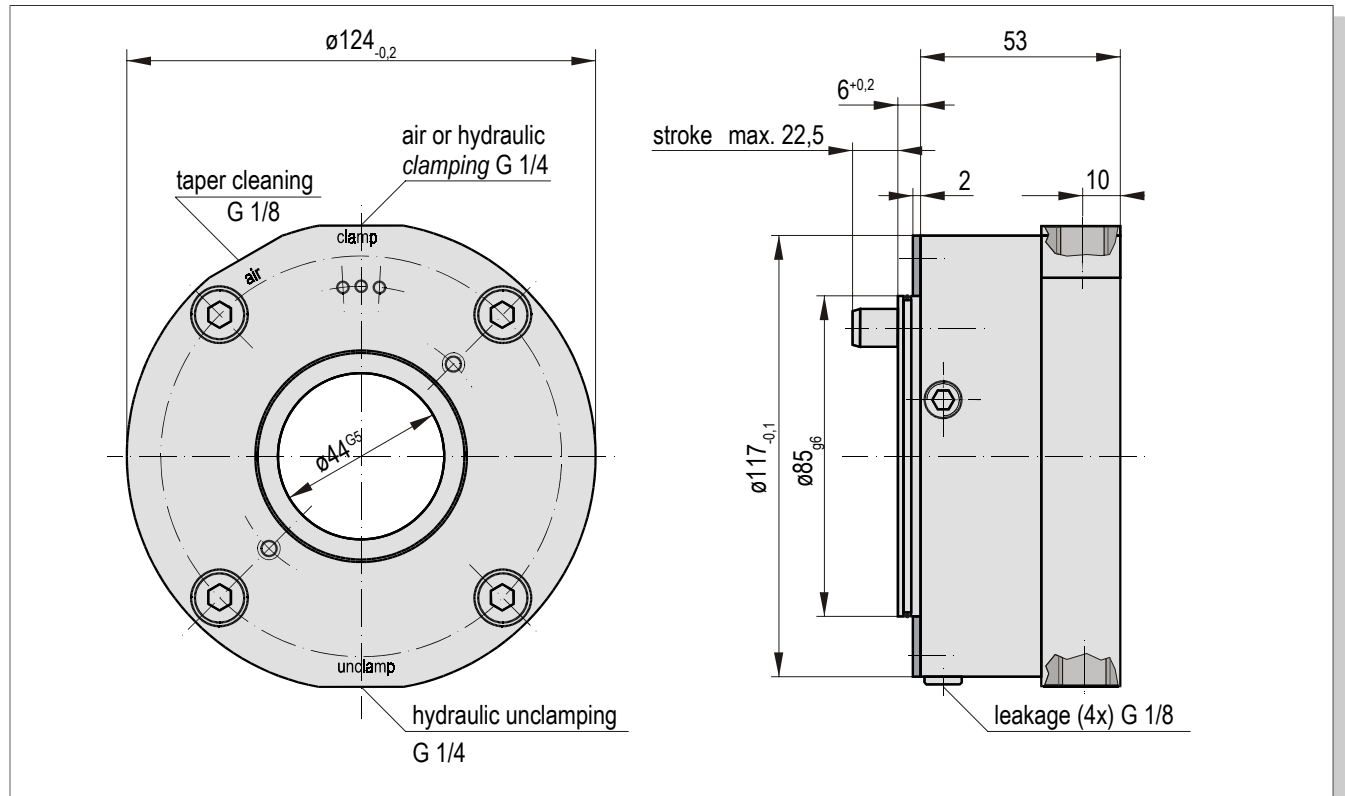

technical data

| | | |
|--|-------|-----------------|
| release pressure at 120 bar..... | 38,5 | kN |
| piston area <i>unclamping</i> | 32,11 | cm ² |
| piston area <i>clamping</i> | 19,55 | cm ² |
| hydraulic pressure <i>unclamping</i> max. | 120 | bar |
| air or hydraulic pressure <i>clamping</i> min..... | 5 | bar |

features

- short design
- easy to assemble
- RPM independant
- leakage connection
- purge passage
- suitable for holding 1K-rotary unions

code

| | |
|---|---|
| 1 | 1 |
|---|---|

Subject to modification due to technical advance!

95.100.258.D.E / 2002-09