

## dimension

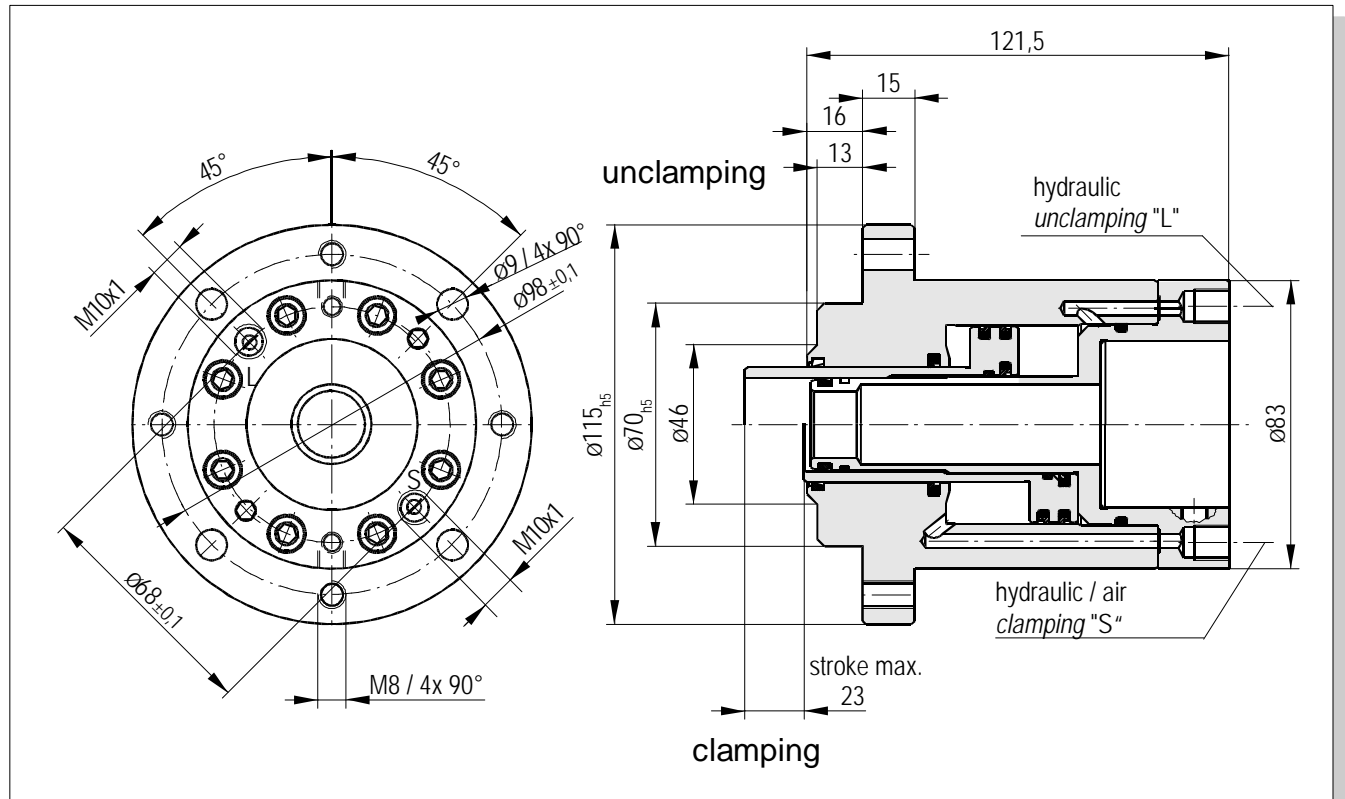

## technical data

piston area "L".....	19,36	cm <sup>2</sup>
piston area "S".....	17	cm <sup>2</sup>
hydraulic pressure "L" max.....	160	bar
hydraulic / air pressure "S" min.....	5	bar

## features

- easy to assemble
- suitable for holding 1K-rotary unions

### code

0	4
---	---