

Measurement System for Production Measuring

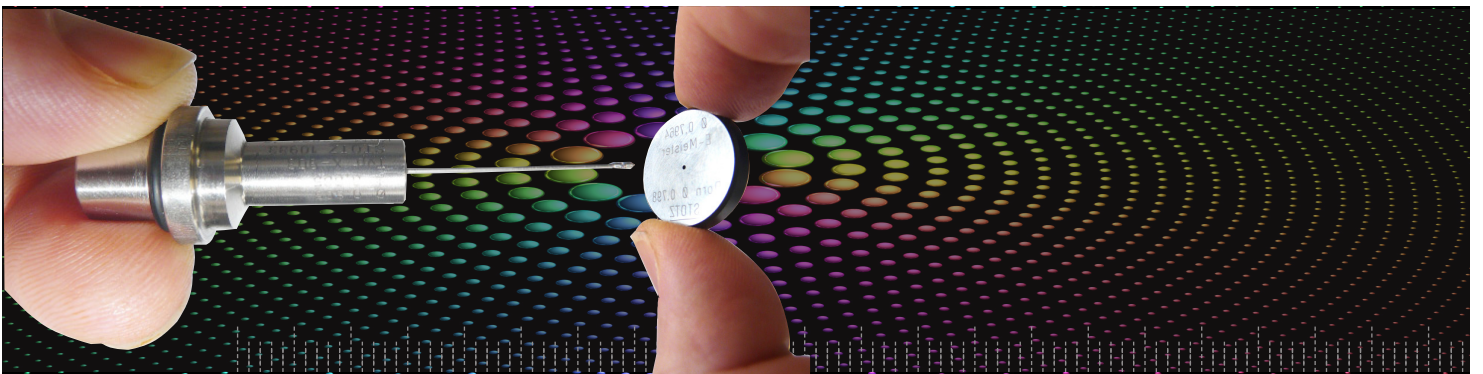

CENTERLESS

CENTERLESS

Short Description

The pneumatic measurement technology shows its strength especially in areas with coolant. Centerless-measuring devices use this advantage. The grinding machine will be adjusted immediately after the manufacturing process. The Centerless control provides the precision correction data without generating an oscillating behavior. The workpiece conveyor is specifically designed for centerless applications. The Centerless flexible system is able to measure different diameters without changing parts and the intelligent contour control displays any grooves or holes that are present in the part. The following components are used for an example:

Used in coolant near grinding wheels



Centerless - Stand

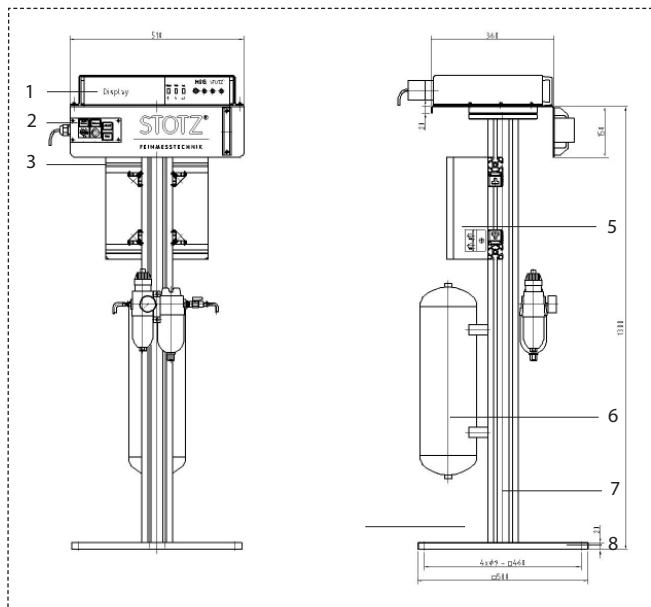

Stotz - Workpiece handling with integrated measuring

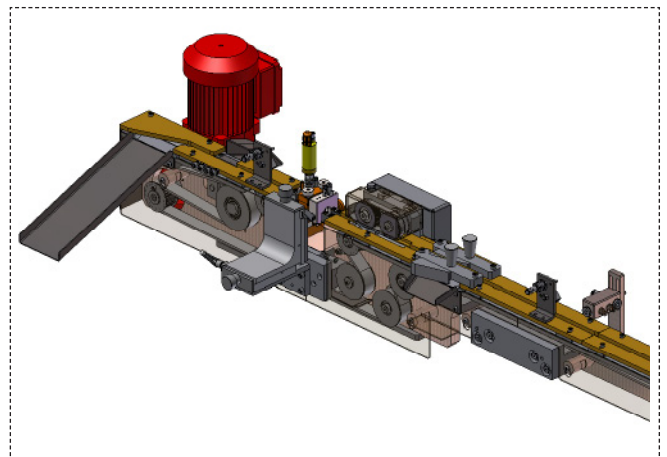

Position	Description
1	Measuring and Controller MSG-64L (Lying Flat)
2	Operating box
3	Swivelling control console
4	Terminal Box
5	Service Unit
6	Air Buffer
7	Stand
8	Base

Technical Data MSG-64L

Equipment Features	
Power Supply	100-230 V AC; 40-60 Hz Autoswitch; 25 VA
Graphic-Display	64 x 256 Pixel
Measuring programs	18
Connection for Operator box	available
Serial Interface	RS232 COM1
Digital Input 24 V; 4 mA	4
Digital Output 24 V; 100 mA	4
Enclosure	IP 52
Dimensions	447 x 221 x 88 mm

Multi-Function Measuring and Control MSG-64L Version 19"



Technical Data SPW

Equipment Feature	
Power Supply	24 V DC / 24 VAC / 50 Hz
Power Consumption	1 VA
Output Voltage	± 10 V (\pm V FSC)
Linearity	$\leq 0,5\%$ of measuring range
Functional Range	18...36 V DC
Output Current	max. 5 mA
Pressure	$3,0 \pm 0,1$ bar
Air Consumption	appx. 2 m ³ /h when free blowing
Requirements	oil free/filtered
Response Time	30 ms
Translaction	100 mV/ μ m
Enclosure	IP 65
Temp.	5 ... 60 °C (permissible ambient temperature)
Dimensions	64x 52x 98 mm



Technical Data DSPW

Features	
Power Supply	24 V DC / 24 VAC / 50 Hz
Power consumption	5 VA
Linearity	$\leq 0,5\%$ of measuring range
Functional range	20...60 V DC
External Input	± 12 V
Pressure	$3,0 \pm 0,1$ bar
Air consumption	appx. 2 m ³ /h while free blowing
Requirements	oil free/ filtered
Ethernet	
Response time	40 ms
Enclosure	IP 65
Temp.	10 ... 55 °C (permissible ambient temperature)
D imensions	79/69/136 mm



Connection Principal MSG-64L-SPW/1

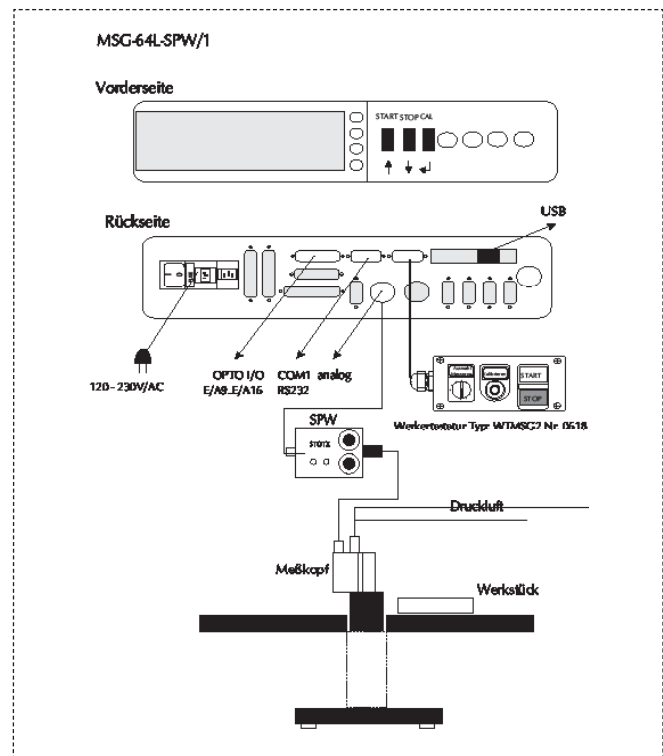

9 offices worldwide

USA

Advanced Machine & Engineering Company
– sales- and service-branch

Germany

STOTZ Feinmesstechnik GmbH
– head office
– 4 sales- and service-offices

France

STOTZ France
– sales- and service-branch

Italy

STOTZ Italia
– sales- and service-branch

Czech Republic, Slovakia

STOTZ Slowakei
– sales- and service-branch



Advanced Machine & Engineering Company
2500 N. Latham Street
Rockford, Illinois 61103

Phone (815) 962-6076
Fax (815) 962-6483
info@ame.com www.ame.com/stotz