

# Rotary Union 2KLR

## dimension

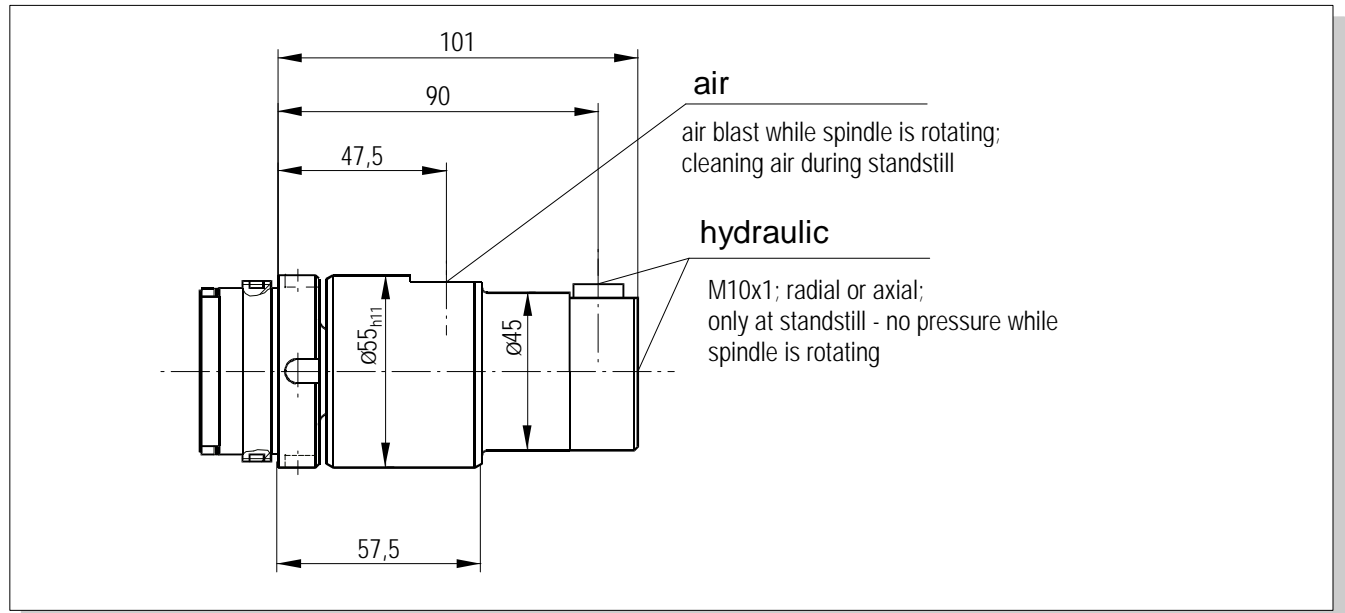

## technical data

spindle speed max. ....	20000	min <sup>-1</sup>
hydraulic pressure max.; n = 0 min <sup>-1</sup> .....	160	bar
air pressure max.....	10	bar

## features

- due to aluminum housing, hybrid spindle bearing and air blast during rotation especially suitable for HSC-operations on wood, plastic, light alloy and other dry operations
- hydraulic unclamping of HSC-power drawbars

## code

2	8
---	---

Subject to modification due to technical advance!

95.100.207.D.E / 98-07