

# Product Information

## Gripper with holder

SK / Form 1

## Table of contents

<b>1</b>	<b>Product Description .....</b>	<b>3</b>
1.1	Standard .....	3
1.2	Medium transfer.....	5
1.3	Dimensions.....	6
1.4	Order number.....	7
<b>2</b>	<b>Assembly .....</b>	<b>8</b>
2.1	Mounting tool SK gripper.....	8
2.2	Gripper with holder SK.....	9
2.3	Finaly inspection .....	10
<b>3</b>	<b>Operation .....</b>	<b>11</b>
<b>4</b>	<b>Maintenance.....</b>	<b>13</b>
4.1	Preventive maintenance schedule .....	13
4.2	Break of a gripper segment.....	13
4.3	Wearing part list.....	14
4.3.1	Gripper SK.....	14
4.4	Trouble shooting SK.....	15

symbol explanation:



# 1 Product Description

## 1.1 Standard

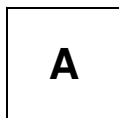

### DIN 69 871 / 69 872 - ISO / DIS 7388 / 1 / 2; Typ A

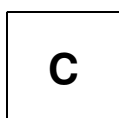
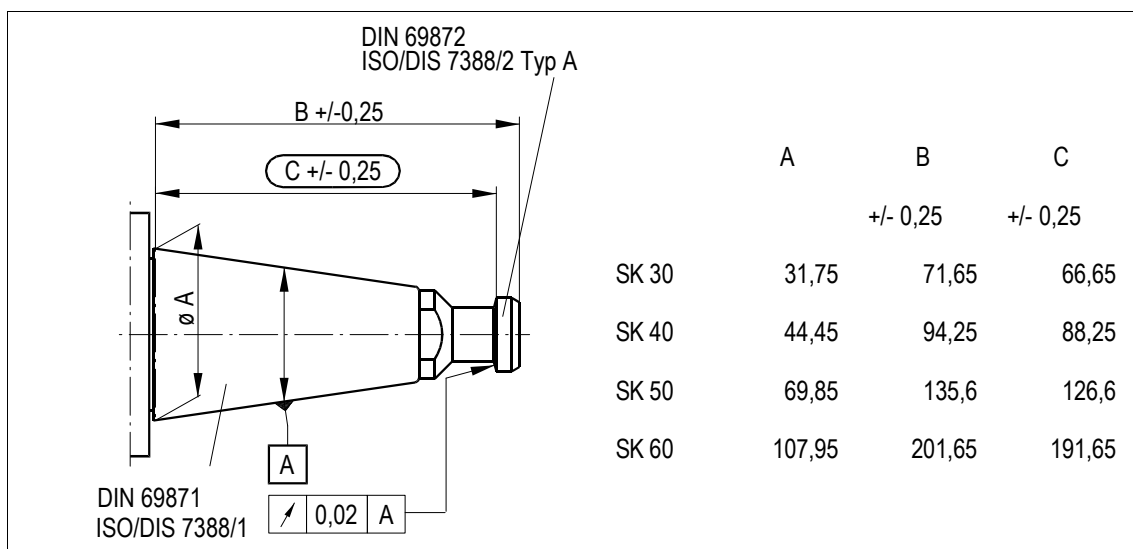

### ANSI B5.50 - ISO / DIS 7388 / 1 / 2; Typ B

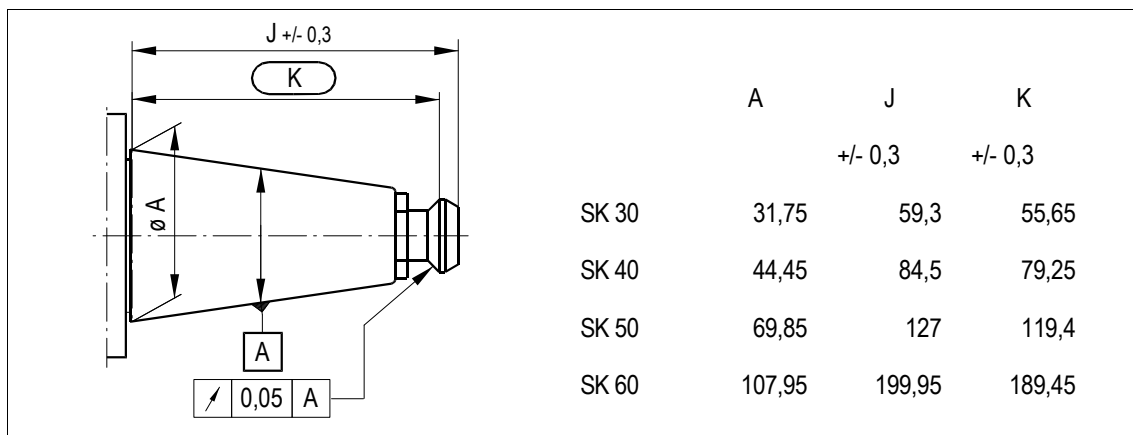

**E**

**MAS 403-1982 BT/PT-2 (30°)**

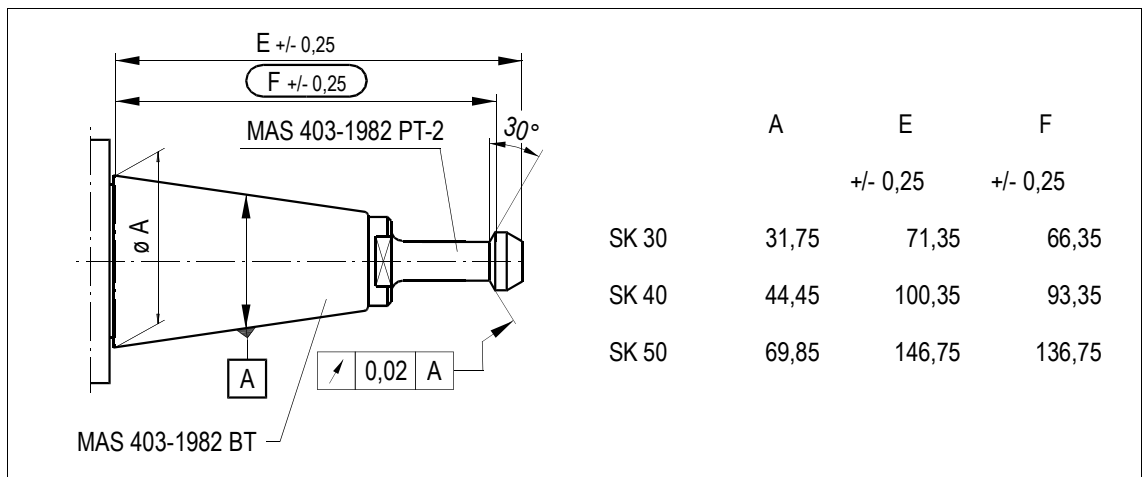

**F**

**MAS 403-1982 BT/PT-1 (45°)**

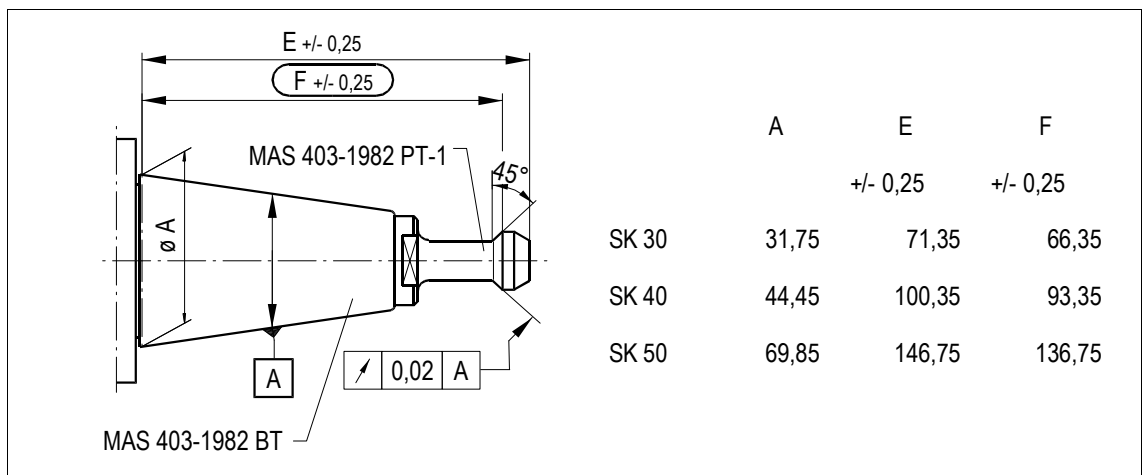

## 1.2 Medium transfer

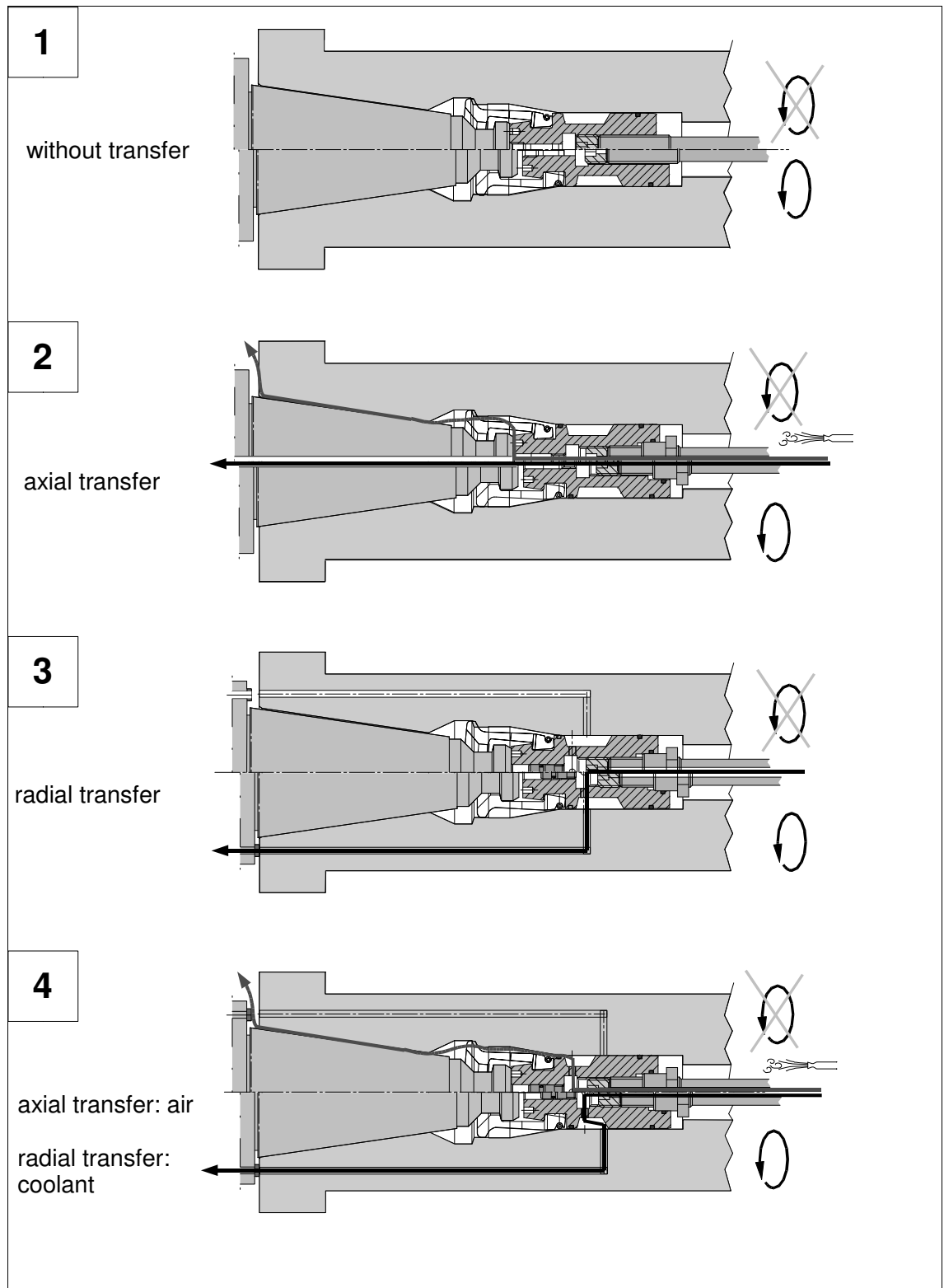

### 1.3 Dimensions

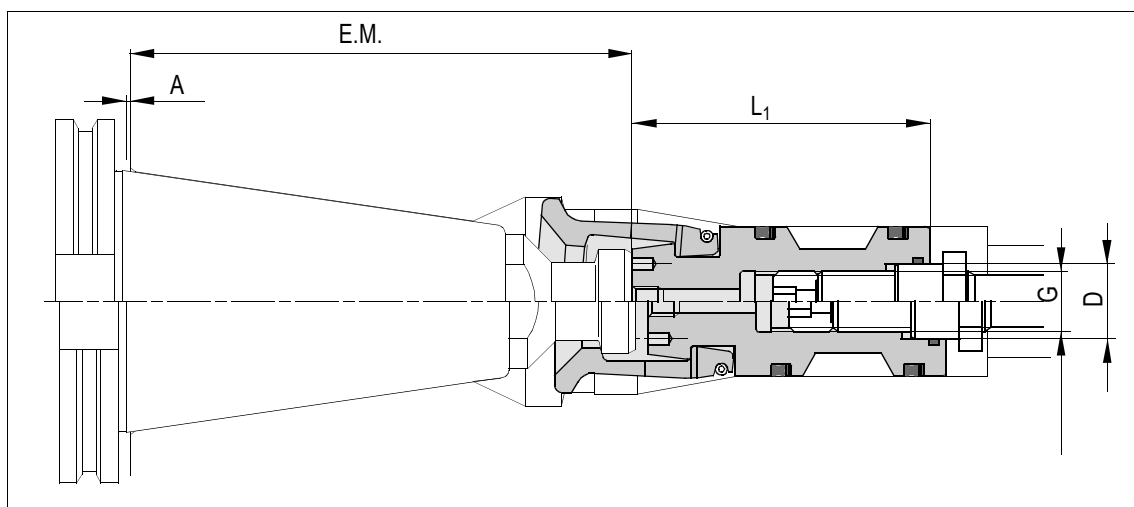

Nominal size	Standard	Mediumtransfer	L <sub>1</sub>	E.M.	A	D	G
30	A	1 / 2 / 3	57,1	70,7	0,95	∅12 <sup>H8</sup>	M10
	C		69,8	57,7	1,6		
	E		57,8	70,4	0,95		
	F		57,8	70,4	0,95		
40	A	1	67,1	93,6	0,65	-	M14x1,5
		2	66,4			∅18 <sup>H8</sup>	
		3	67,4				
		4	67,4				
	C	1	77,9	82,9	1,6	-	
		2	77,5			∅18 <sup>H8</sup>	
		3	77,9				
		4	78,2				
E	1 / 2	60,3	99,7	0,65	∅18 <sup>H8</sup>		
F							
50	A	1 / 2	79,7	134,6	1	∅20 <sup>H8</sup>	M16x1,5
		3					
		4					
	C	1 / 2	87,9	126			
		4					
	E	1 / 2	68,8	145,75			
F							
50 reinforced	A	1 / 2 / 3	95	134,6	1	(∅22 <sup>H8</sup> )	(M25x1,5)
	C		103	126			
60	A	1 / 2	130,5	200,5	1,15	∅26 <sup>H8</sup>	M30x1,5
	C		132,2	199	0,95		

## 1.4 Order number

<i>nominal size</i>	<i>Standard</i>	<i>Mediumtransfer</i>	<i>gripper with holder</i>	<i>lock screw</i>		
30	A	1 / 2 / 3	95.101.452.3.2			
	C		95.101.450.3.2			
	E		95.101.453.3.2			
	F		95.101.451.3.2			
40	A	1	95.101.288.3.2	95.101.372.5.1		
		2	95.101.216.3.2			
		3	95.101.202.3.2			
		4	95.101.223.3.2			
	C	1	95.101.287.3.2			
		2	95.101.233.3.2			
		3	95.101.290.3.2			
		4	95.101.295.3.2			
	E	1 / 2	95.101.485.3.2			
			95.101.486.3.2			
	50	A	1 / 2		95.101.297.3.2	95.103.636.5.1
			3		95.101.298.3.2	
4			95.101.356.3.2			
C		1 / 2	95.101.306.3.2			
		4	95.101.522.3.2			
E		1 / 2	95.101.476.3.2			
	95.101.506.3.2					
50 reinforced	A	1 / 2 / 3	95.101.781.3.2	95.101.273.4.1		
	C		95.101.782.3.2			
60	A	1 / 2	95.101.308.3.2	95.101.092.4.1		
	C		95.101.307.3.2			

## 2 Assembly

### 2.1 Mounting tool SK gripper

(not included with delivery)

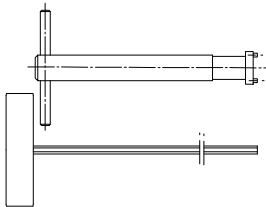
	nominal size	order-no.
	SK 30	95.101.280.9.2
	SK 40	95.101.281.9.2
	SK 50	95.101.337.9.2
	SK 50 reinforced	95.101.336.9.2
	SK 60	95.101.284.9.2



## 2.2 Gripper with holder SK

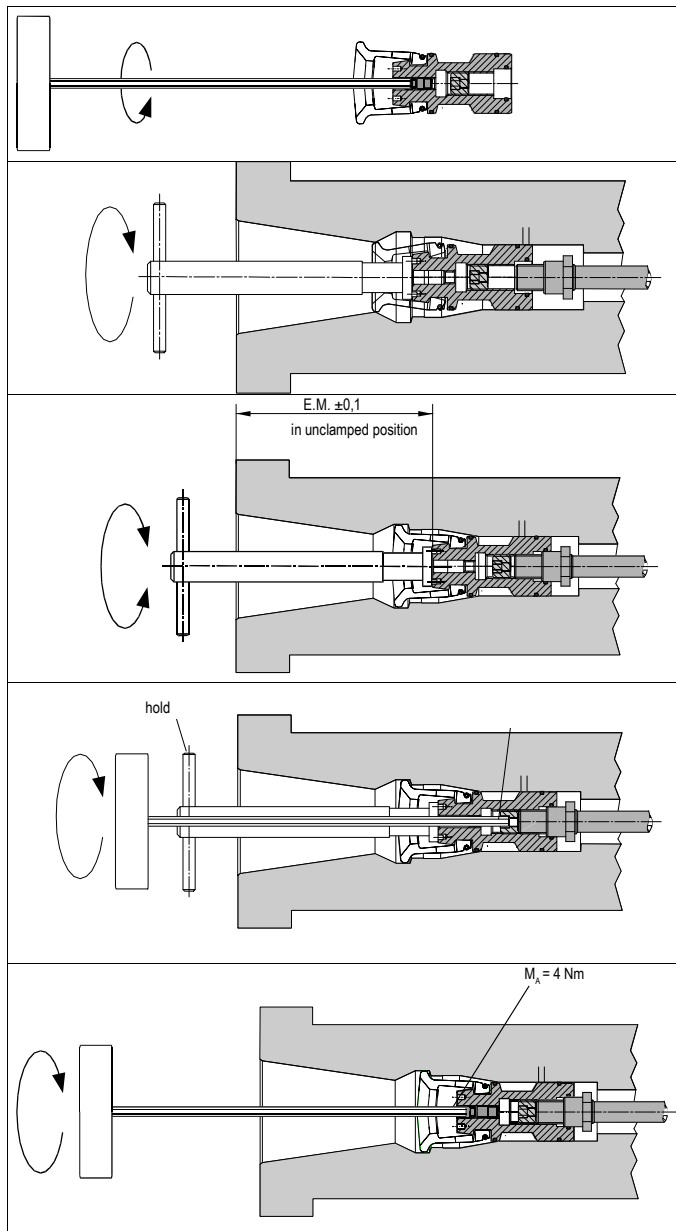

*if necessary:*

- Remove sealing screw (if needed)
- mount the gripper with holder on the drawbar
- adjust at gauge dimension E.M.

- fix gripper with holder in place: tighten lock screw firmly

*if necessary:*

- screw in seal screw and tighten it

## 2.3 Final inspection

Check after approx. 100 strokes

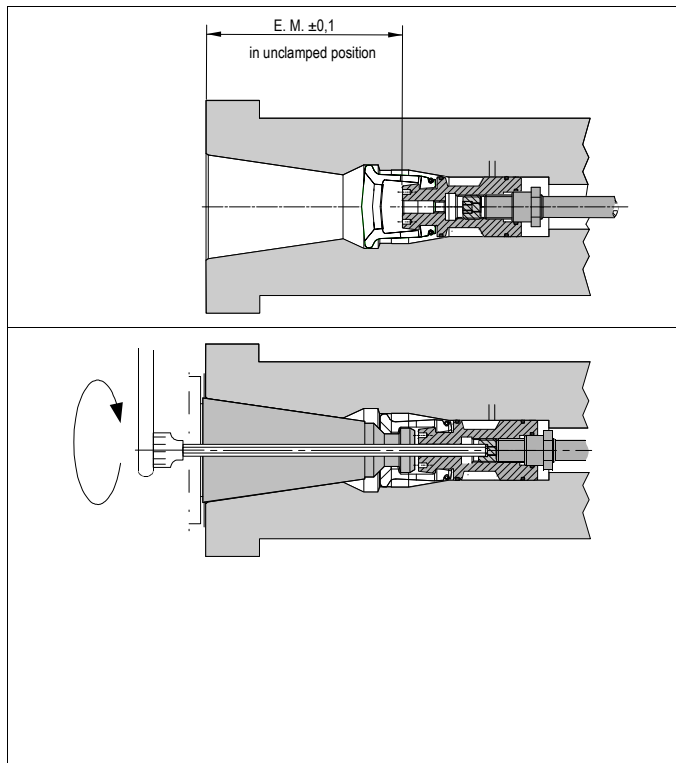

➤ Check dimension gauge E.M.

➤ Tighten lock screw through a clamped tool

tightening torque  $M_A$ :

- SK 30: 10 Nm (M8)
- SK 30: 20 Nm
- SK 40: 30 Nm
- SK 50: 50 Nm
- SK 60: 100 Nm

check valve

tightening torque  $M_A$ :

- SK 40: 18 Nm
- SK 50: 18 Nm

### 3 Operation

**ATTENTION**

**No rotation without clamped tool!  
Only use technically perfect tools!**

**Important**

- Do not insert tool into the spindle taper when rotating
- During tool changes it is very important that the tool must be pushed into the spindle taper and held in place until the drawbar starts pulling
- Recommendation: install a limit switch for the drawbar
- Follow preventive maintenance schedule!

#### Unclamp Force

In our file, you will find calculated values of the minimum unclamp force and unclamp pressure to eject the tool. This is based on a well serviced interface of male and female taper. ; ⇒ Preventive maintenance schedule - Every week.

In rare cases the unclamp force may exceed the theoretical values and malfunction may occur.

Unclamp force depends on:

- Unclamp speed (In pulse)
- Thermal condition of spindle
- Surface quality of taper in spindle
- Contact pattern of spindle/steep taper shaft.  
(See test records of steep taper obtainable thru [techdoku@ott-jakob.de](mailto:techdoku@ott-jakob.de))
- Mechanical overload of the interface

**Important****Coolant**

Guidelines and technical specifications for the coolant use in the machine:

Coolant use must conform to the current regulations of the legislation and the professional association.

Our products are to the greatest possible extent protected by the materials used or by means of a passivated surface against corrosion and therefore suited for use with water. The rate of corrosion is strongly dependent on the contents of the media (e.g. chlorine is very much increasing the rate of corrosion), as well as the environment in which the products are being operated (e.g. the difference in electrical potential between rotor and stator in spindles). Suitable protective measures such as the utilization of corrosion inhibitors will extend the service life in every way.

Furthermore, you must only use coolants which conform with the specs listed on the table below.

Parameter / test procedure	Limited values
Corrosion protection according to DIN 51360 section 2	No corrosion after 2 hours
Elastomer compatibility	No change of the shore hardness and/or the elongation OTT-JAKOB applies FKM (VITON®)
Nonferrous metal compatibility	No corrosion on copper, brass and aluminum parts
Glue residue after slow evaporation at 50 degrees	Non sticky! No residue! Easily removable.

## 4 Maintenance

### 4.1 Preventive maintenance schedule

To guarantee the function of the power drawbar the following preventive maintenance schedule must be adhered to.

#### Every week

- Check the gripper if it is polluted or damaged (visual check)
- Apply *Klueber Altemp Q NB50* to Spindle taper for service

#### Every six month or after 200.000 tool changes at the latest

- In unclamped position: Check dimension gauge E.M.
- check the secure fit of the lock screw through a clamped tool
- test pull-in-force  
(we recommend: use **POWER-Check** )

If the pull-in-force is smaller than 70% of the nominal value, the following procedures have to be performed in the following sequence:

- check gripper if it is polluted or damaged;  
clean it if necessary; test again
- exchange gripper and test again
- exchange drawbar completely

### 4.2 Break of a gripper segment

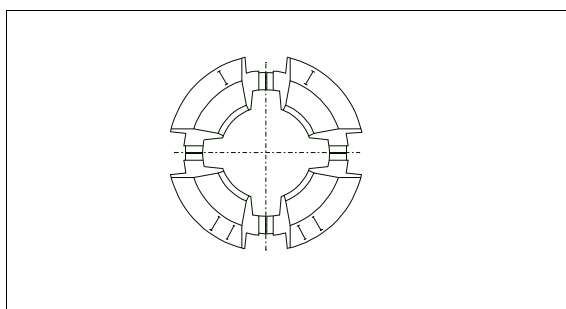

- If one of the gripper segments should break, the complete set of grippers needs to be replaced. On assembly mind the order of the segments.

## 4.3 Wearing part list

### 4.3.1 Gripper SK

code	standard	nominal size	order number	sign
A	DIN 69871 / 69872 ISO 7388/1/2 Typ A	SK 30	95.103.597.2.1	9
		SK 40	95.102.437.2.1	36
		SK 50	95.102.914.2.1	69
		SK 50 reinforced	95.102.104.2.1	66
		SK 60	95.102.327.2.1	83
B	DIN 2080 - OTT-Rille	SK 30	95.103.599.2.1	91
		SK 40	95.102.432.2.1	32
		SK 50	95.102.916.2.1	70
		SK 50 reinforced	-	
		SK 60	-	
C	ANSI B5.50 - 78 ISO 7388/1/2 Typ B	SK 30	95.103.598.2.1	90
		SK 40	95.102.436.2.1	35
		SK 50	95.102.915.2.1	71
		SK 50 verstärkt	95.102.183.2.1	68
		SK 60	95.102.328.2.1	84
E	MAS 403-1982 BT/PT 2 (30°)	SK 30	95.103.595.2.1	7
		SK 40	95.103.514.2.1	38
		SK 50	95.103.535.2.1	73
		SK 50 reinforced	-	
		SK 60	-	
F	MAS 403-1982 BT/PT 1 (45°)	SK 30	95.103.596.2.1	8
		SK 40	95.103.513.2.1	37
		SK 50	95.103.534.2.1	72
		SK 50 reinforced	-	
		SK 60	-	

## 4.4 Trouble shooting SK

Malfunction	Reason
Tool is not pulled in correctly	gauge dimension out of adjustment
	lock screw got loose
	wrong gripper installed (tool standard)
	wrong or faulty spindle-inside-contour
	retention knob not correct or faulty
	tool not sufficiently pressed in during clamping
	air blow off prevents tool from seating during tool change
Tool is not released	insufficient service of the steep taper interface
	accumulated rust on the steep taper
Tool is pulled out during working cycle	gripper or clamping cone broken
	retention knob or steep taper broken
	tool too long / short