

Unclamp Unit LE 102-B

dimension

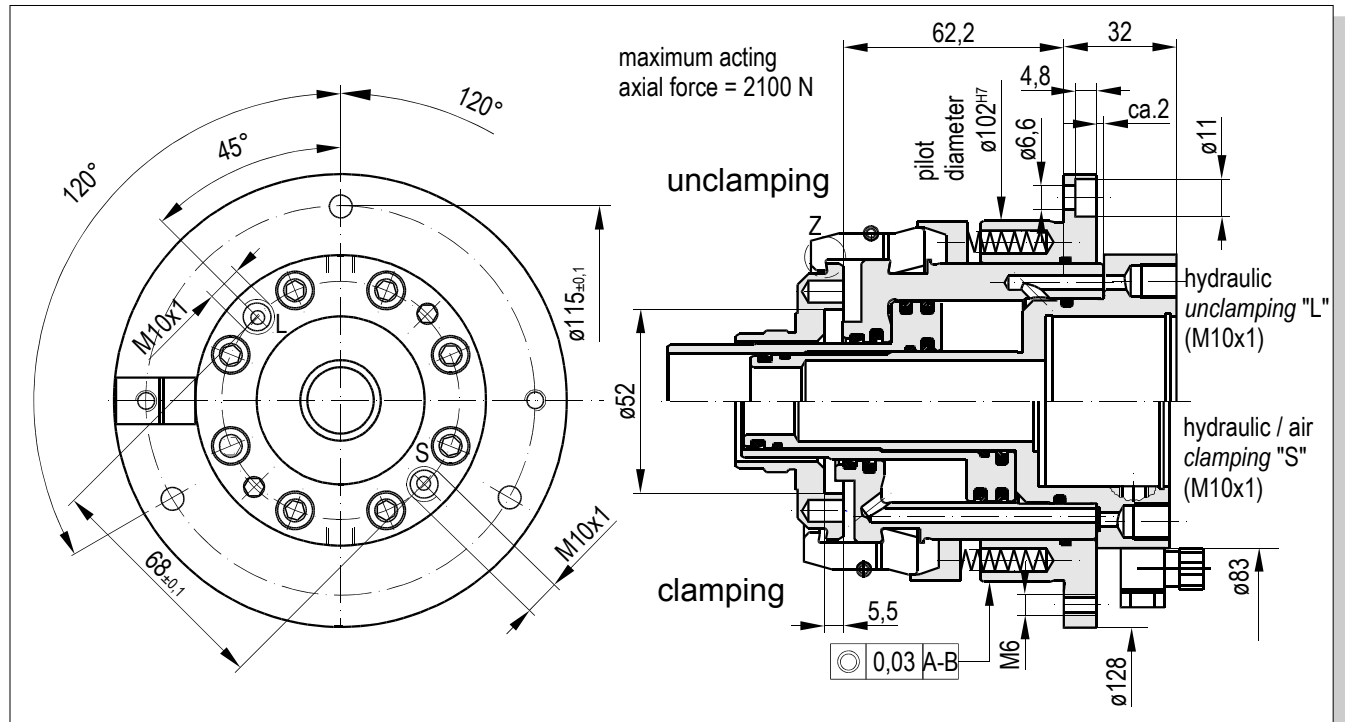

gripper contour

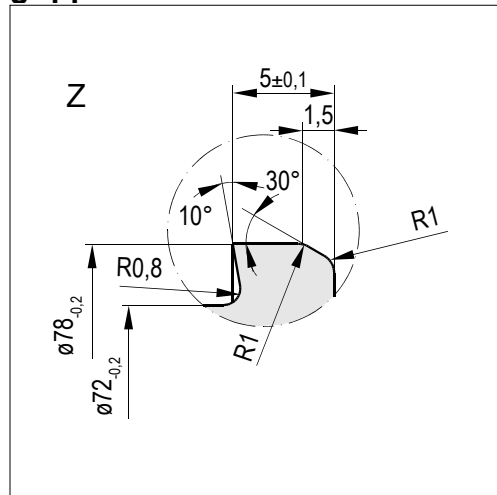

technical data

piston area "L".....	19,36	cm ²
piston area "S".....	17	cm ²
hydraulic pressure "L" max.....	160	bar
hydraulic / air pressure "S" min.....	5	bar

features

- purge passage
- low bearing load
- easy to assemble
- RPM independant
- suitable for holding 1K-rotary unions

code

0	3
---	---

Subject to modification due to technical advance!

95.100.221.D.E / 2002-10