

# Unclamp Unit LE 115

## dimension

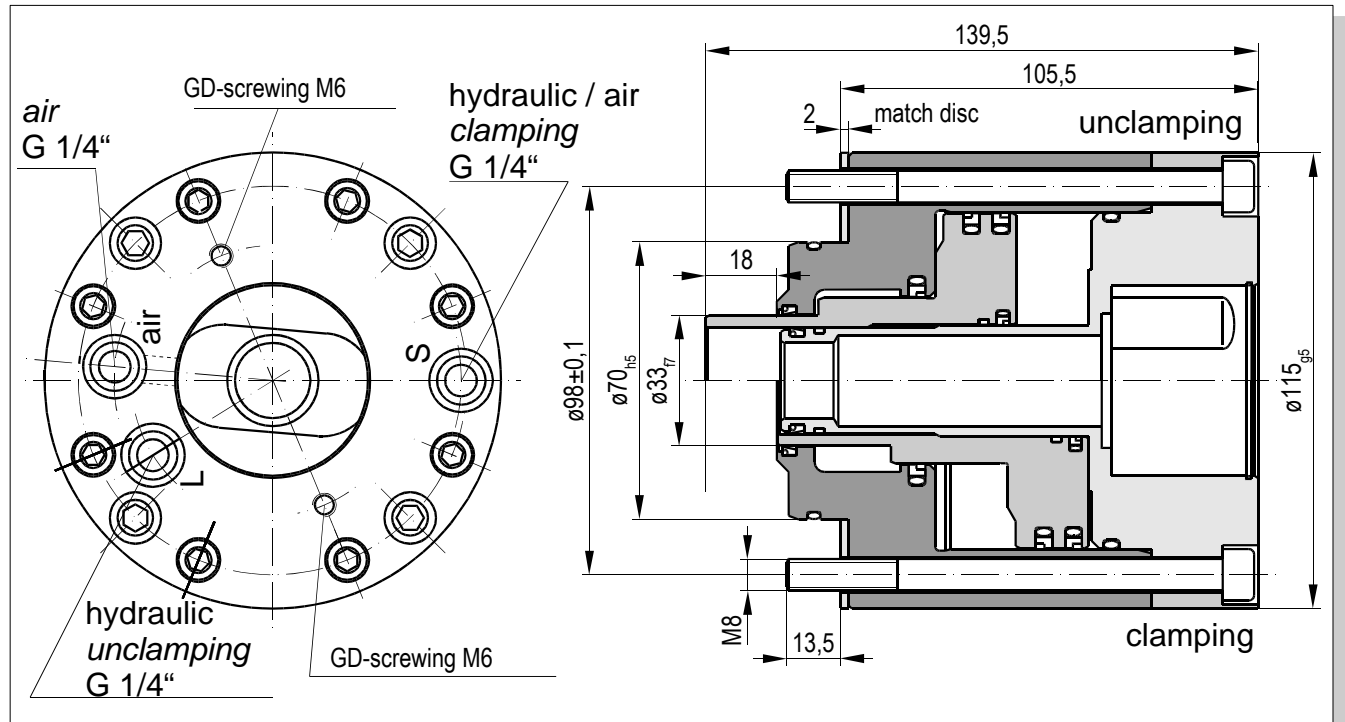

## technical data

piston area "L" .....	50,6	cm <sup>2</sup>
piston area "S" .....	42,9	cm <sup>2</sup>
hydraulic pressure "L" max.....	120	bar
hydraulic / air pressure "S" min.....	5	bar

## suitable for indicating position

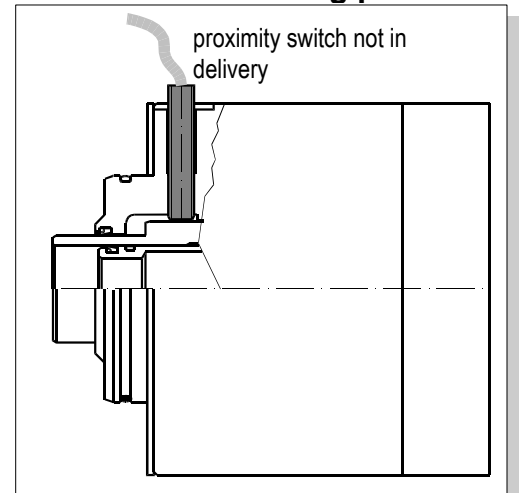

## features

- easy to assemble
- RPM independant
- suitable for holding 1K-rotary unions

## code

1	0
---	---

Subject to modification due to technical advance!

95.100.240.D.E / 1999-11