

# TRIAG

INTERNATIONAL

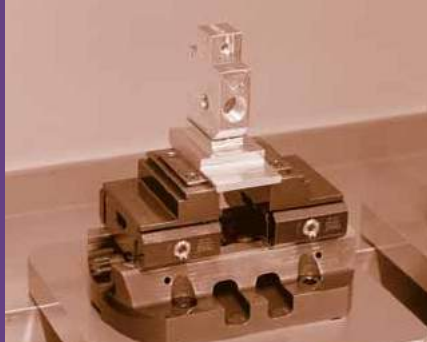

**powerCLAMP**



**triCENTRO**

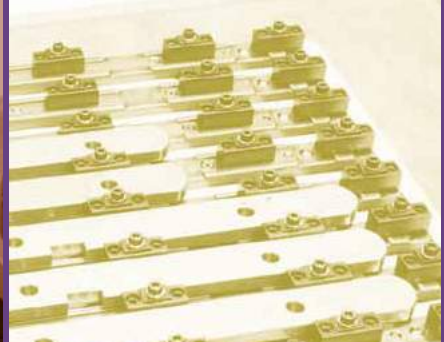

**microCLAMP  
compactCLAMP**



**aptoCLAMP**



**tripoxyMINERAL**

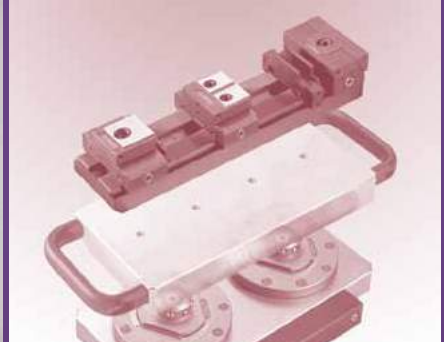

**oppSystem**



**trivaCLAMP**

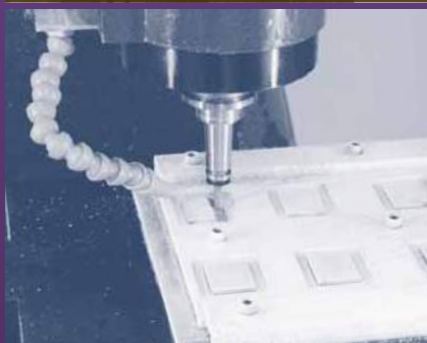

**triGEL**



**Zubehör  
Accessories**

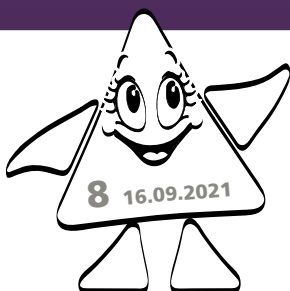

## Gesamtkatalog General catalogue



Aktuellste Version / Latest version : [www.triag-int.ch/download/gk](http://www.triag-int.ch/download/gk)

Eigenes Engineering  
Eigene Produktion  
Weltweiter Vertrieb

*In-house Engineering  
In-house Manufacturing  
Worldwide distribution*



**Triag International AG**   
Boesch 84 / CH-6330 Huenenberg

**triag-int.ch**   
Official Website

**1990** Seit der Gründung der **Triag AG** im Jahre 1990 entwickelten und produzierten wir Spannsysteme für die spanabhebende Fertigung für den Weltmarkt und vertrieben Zerspanungswerkzeuge namhafter Hersteller in der Schweiz.

**HEUTE** Ab dem 1. Juli 2013 konzentrieren wir uns unter dem neuen Namen **Triag International AG** auf die Entwicklung, Produktion und den weltweiten Vertrieb unserer Spannsysteme.

Unsere Motivation ist es, für unsere Kunden den grösstmöglichen Nutzen ihrer Anlagen zu fördern. Sei es mit unserem tiefen und breiten Sortiment an Modularspanntechnik oder mittels werkstückspezifischen Sonderlösungen. Unsere modularen Spannsysteme finden Anwendung von der konventionellen Fräsmaschine bis zu 5-Achsen Fräszentren mit und ohne Automatisierung. Diese Effizienz nutzen wir auch in der Herstellung unserer Spannsysteme in unserer modernen Fertigung.

Auf ein gutes Arbeitsklima und unsere Umwelt legen wir sehr grossen Wert, denn nur mit einem funktionierendem Team und einem grossen Umweltbewusstsein können wir unsere Kunden offen und nachhaltig bedienen.

**1990** Since the formation of **Triag AG** 1990 we have developed and produced workholding systems for the world market. Beside that we sold cutting tools also for the swiss market.

**TODAY** Since the 1st of July 2013 **Triag International AG** concentrates on workholding systems for the world market. Our goal is to develop, produce and distribute solutions for all application in the metal cutting industry.

Our motivation is to give our customers the best support to achieve the highest output of their investments in machine tools. We offer modular vise systems as standard and dedicated solutions for the highest performance. The modular system find it's application from conventional machines to high end 5-axis automated systems as well as many time on horizontal machines. Naturally we use for our production our own clamp systems so we have our own practical experience.

In a good working atmosphere and environment, we attach great importance, because only with a functioning team and a great environmental awareness, we can serve our customers open and sustainable.



# UNSERE MOTIVATION OUR MOTIVATION

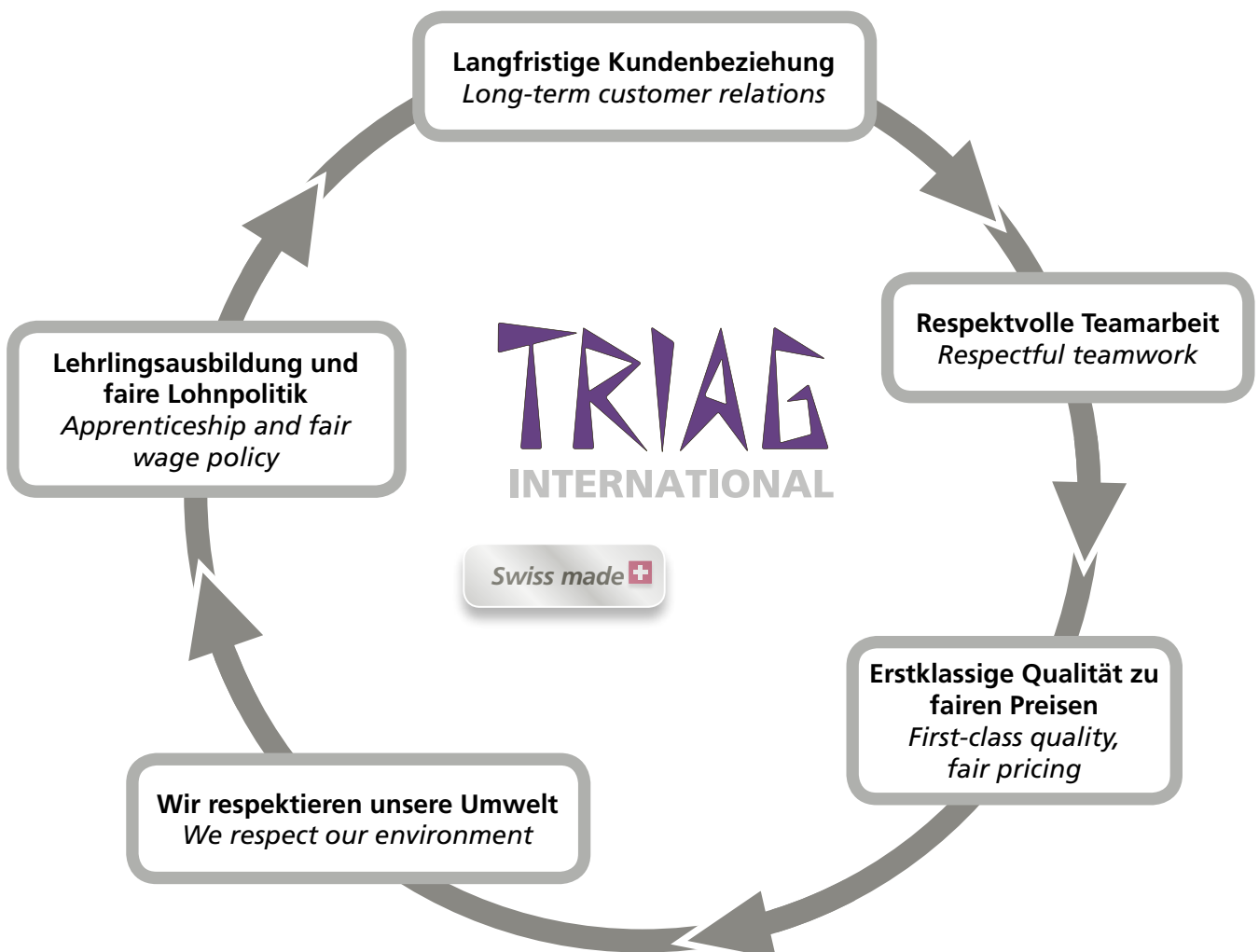



	<b>Informationen</b> <i>Informations</i> .....	5 - 2
	<b>powerCLAMP</b> Modulares Spannsystem <i>Modular workholding system</i> .....	13 - 112
	<b>triCENTRO</b> Zentrischspanner <i>Self centring vises</i> .....	113 - 162
	<b>microCLAMP</b> Vorrichtungsbau Module <i>Clamp modules for dedicated fixtures</i> .....	163 - 206
	<b>aptoCLAMP</b> Modulares Spannsystem für die Schwerzerspannung <i>Heavy duty modular workholding system</i> .....	207 - 234
	<b>tripoxyMINERAL</b> Mineralguss und Stahlmineralgusstürme <i>Epoxy and steel epoxy mineral tombstones</i> .....	235 - 278
	<b>oppSystem</b> Nullpunkt Spannsysteme <i>Zero point systems</i> .....	279 - 302
	<b>trivaCLAMP</b> Vacuum Spannsysteme <i>Vacuum systems</i> .....	303 - 328
	<b>triGEL</b> Gefrierspannen <i>Workholding by freezing</i> .....	329 - 332
	<b>Allgemeines Zubehör</b> <i>General accessories</i> .....	333 - 340
	<b>Index</b> .....	341 - 346



Mass- und Konstruktionsänderungen bleiben uns vorbehalten.  
*We reserve the right to modify dimensions and structural design.*





Time to say goodbye  
to the dinosaur vises!



# Warum moderne Spannsysteme nutzen ? *Why using modern workholding system*

In Ihrem Gebäude werden doch auch alle Wohnungen vermietet...

*Don't you rent out all flats in your building? So...*



...weshalb nicht auch in Ihrem  
Bearbeitungszentrum?

*...why not in your CNC milling  
machine?*

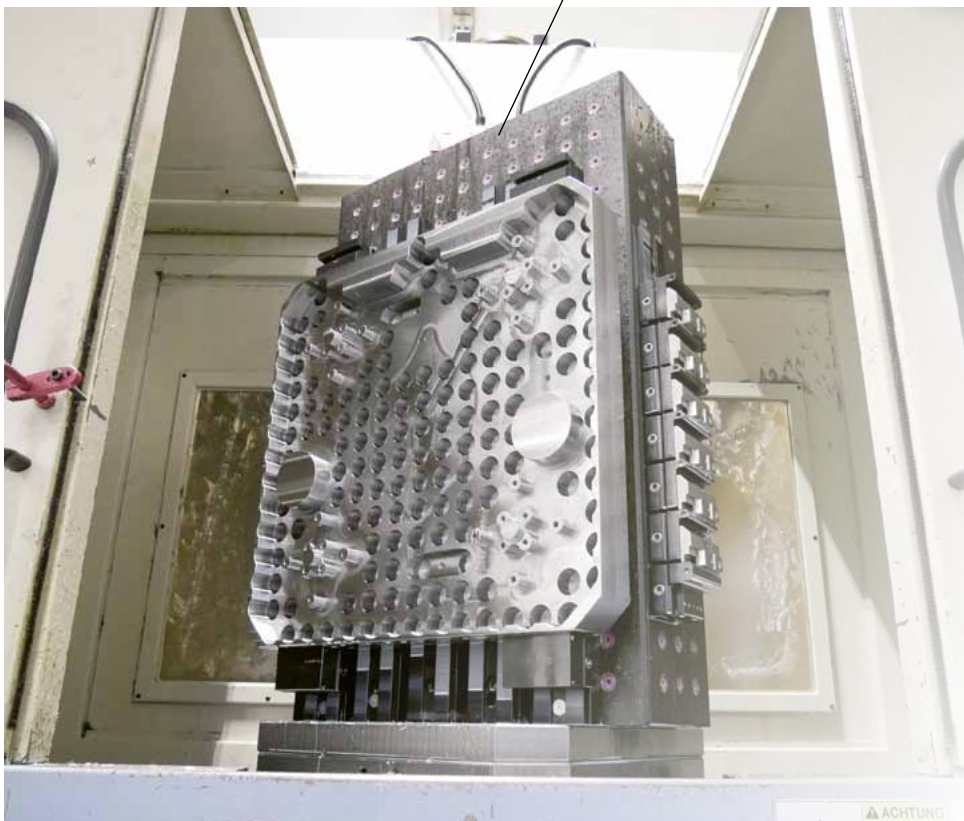



**80%**

...aller Bearbeitungszentren werden nicht voll ausgenutzt!  
...of all machines are not fully used!



Max. mögliche Bearbeitungsgrösse  
Max. working area



Verschwenden Sie nicht einen Grossteil Ihrer Investition!  
Don't waste a great part of your investment!

## Die Lösung:

### **Modulares Spannen! Oder Sondervorrichtungen!**

Mit unseren modularen Spannsystemen adaptieren Sie einfach und schnell einzelne oder mehrere Werkstücke in Ihrem Maschinen Verfahrensbereich. Das Umrüsten wird schneller und es können viel mehr Werkstücke gespannt werden.

## The solution:

### **Modular workholding! Or dedicated fixtures!**

With our modular workholding devices you change fast and adapt one or more workpieces into your machine xyz travel envelope ! You can clamp more than one or two parts at once.

# «Modular» bedeutet:

## 3 dimensionales Anpassen an Werkstück und Maschine

### Vorteile des modularen Mehrfachspannens:

- Möglichkeit der chaotischen Produktion
- Schneller Werkstückwechsel
- Vielseitigkeit durch Kombination mehrerer Komponenten, 3D modular (Schienen, mechanisch oder hydraulisch betätigte Spannelemente etc.)
- Einfache Montageprozesse
- Lange Lebensdauer, geringe zusätzliche Instandhaltungskosten
- Beschädigte Komponenten können einfach ersetzt werden
- Längere unbemannte Laufzeit
- Deutlich weniger Werkzeug- und Palettenwechsel
- Schont die Maschine, da der gesamte Bearbeitungsraum genutzt wird
- Preis: Kann trotz der Vorteile mit einem Spannstock mithalten
- Geringerer Aufwand in der Logistik, Lagerhaltung und Beschaffung
- Höhere Spanndichte, mehr Teile aufgespannt
- Spannen von kleinen wie grossen Werkstücken

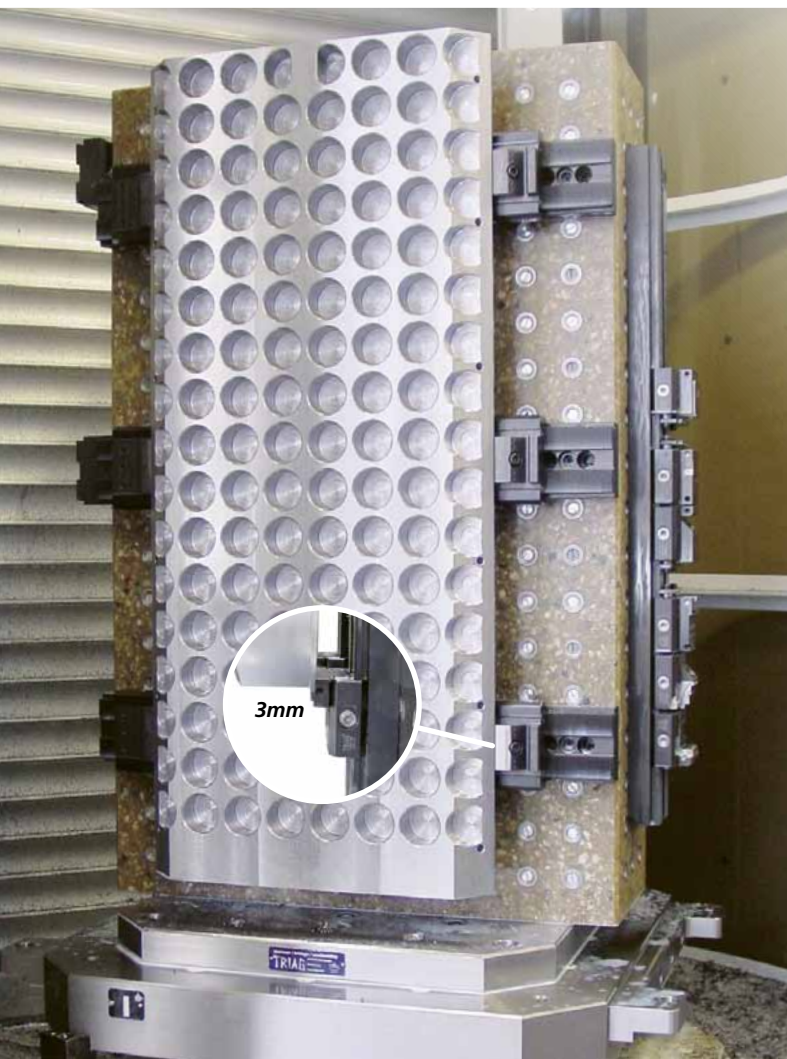



# «Modular» means:

*Adapting to workpiece and machine situation in 3 dimensions*

## **Advantage of modular workholding:**

- Possibility of chaotic manufacturing
- Fast workpiece change
- Flexibility because of different components, 3D modular
- Simple to set up
- Cost effective
- Easy to replace spare parts
- Long unmanned production
- Less tool changes
- The machines are used in the whole working area
- Competitive price to standart vises
- Simple to be purchased and used on different machines
- High density workholding, you clamp more parts!
- Long and reliable live with low maintenance cost

Chaotische Spannung (Tripoxy Mineral) mit unterschiedlichen Werkstücken bestückt.  
Optimale Nutzung eines Horizontal-Bearbeitungszentrums.

*Mixed set up on a Mazak horizontal machine with  
18 pallets. This is used for unmanned production of  
small quantities of different materials.*

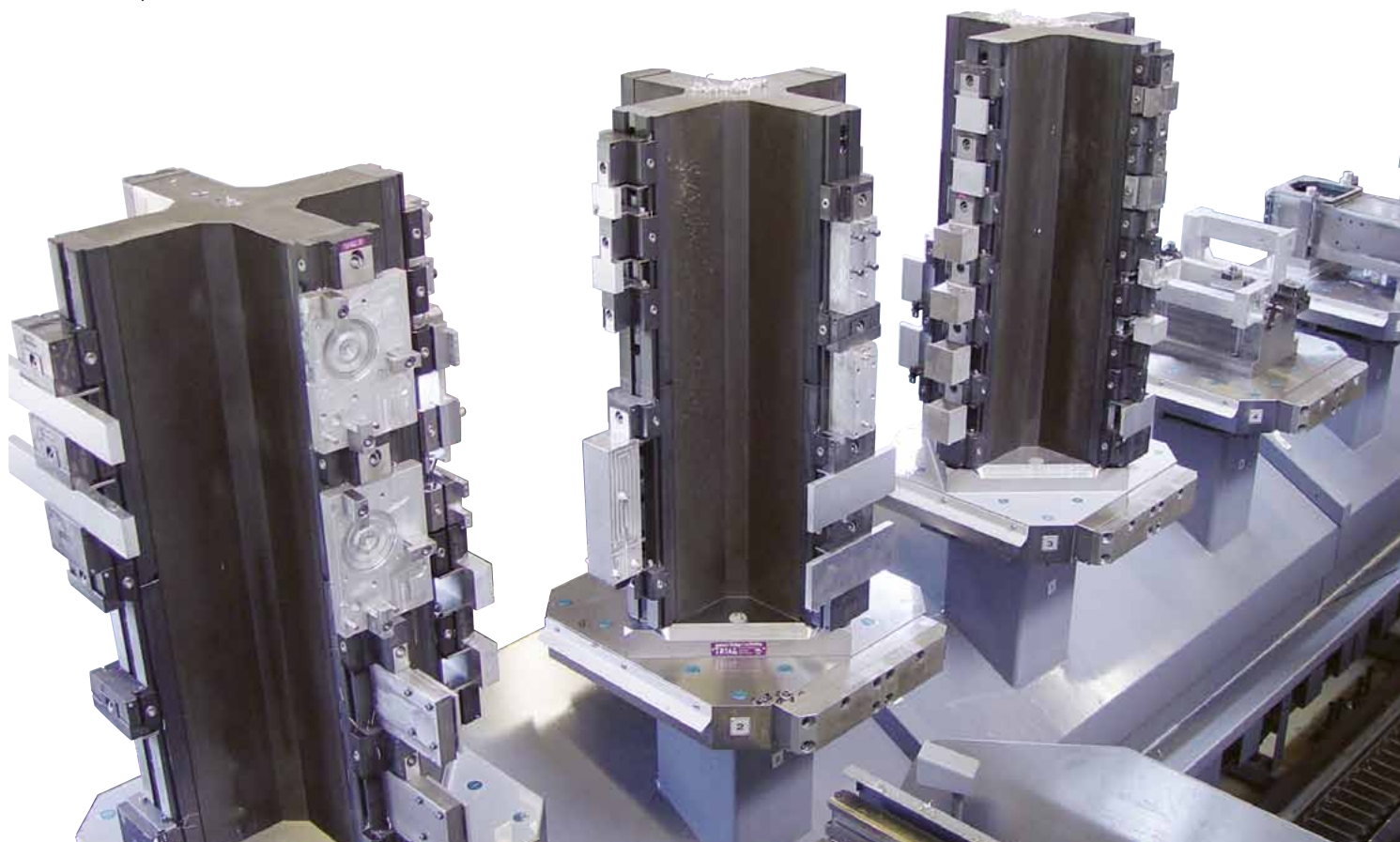

Modulare Mehrfachspannsysteme werden in ihrer Bedeutung für die Zerspanung noch immer unterschätzt. Dabei sind sie sowohl in der Einzelteilfertigung als auch für Grossserien flexibel einsetzbar. Zurückzuführen ist diese Flexibilität auf das Konstruktionsprinzip der Systeme, ihre handhabbare, kompakte Bauweise wie auch die hohe Spannkraft und Spanndichte.

Bei der Beurteilung modularer Mehrfachspannsysteme gibt es eine eigentümliche Konstellation: Zum einen sieht der Einzelteil- und Kleinserienfertiger enorme Vorteile für die Anwendung in der Serienfertigung, beispielsweise rückbaubarer Vorrichtungsbaukasten. Zum anderen erkennt der Serienfertiger genau diese Vorzüge für die Einzelteil- und Kleinserienfertigung. Diese Sichtweise zu hinterfragen und zu verdeutlichen, worin die fertigungsspezifischen Vorteile modularer Mehrfachspannsysteme liegen, ist Ziel des Beitrags.

## Modulare Mehrfachspannsysteme sind flexibel anwendbar

Für viele Zerspanungsarbeiten ist der klassische Maschinenschraubstock auch heute noch die passende Spannung. Mit den ständig neuen und erhöhten Anforderungen geht allerdings die Entwicklung der Spanntechnik in eine andere Richtung. Will man ein hohes Mass an Flexibilität und eine grosse Spanndichte erzielen und sollen gleichzeitig verschiedene Werkstücke auf kleinstem Raum gespannt werden, kommt der klassische Maschinenschraubstock oft an seine Grenzen. Häufig führt hier nur ein modulares Mehrfachspannsystem zum Erfolg. Spannsysteme müssen heute möglichst flexibel sein. Damit lassen sie sich an veränderte Umstände anpassen und können so die Wirtschaftlichkeit des Bearbeitungsprozesses erhalten. Modular ist ein Spannsystem, wenn es nach dem Baukastenprinzip aus Elementen zusammengesetzt und erweiterbar ist. Neben diesen grundsätzlichen Eigenschaften bedarf das Spannsystem jedoch weiterer prägnanter Merkmale: So muss es einfach und schnell zu handhaben sein, eine kompakte Bauweise mit hoher Spannkraft und Spanndichte verbinden und möglichst autarke Spannstellen aufweisen, deren Spanndruck einzeln zu verstellen ist. Im Idealfall kann mit nur einer Basisschiene ein breites Backenprogramm mit geringem Aufwand aufgebaut werden.

In der Serienfertigung besteht der wohl grösste Vorteil modularer Mehrfachspannsysteme darin, dass sich das System als rückbaubarer Vorrichtungsbaukasten für ein vielseitig gefächertes Werkstückspektrum einsetzen lässt. So spart sich der Anwender oft teilespezifische, teure Vorrichtungen. Mehrfachspannsysteme können zudem das Engineering vereinfachen, da sich auf vorhandenes Spannmateriale zurückgreifen lässt. So sind kurze Planungs- und Umrüstzeiten realistisch. Darüber hinaus trägt das modulare System zur erhöhten Prozesssicherheit bei und fördert die Qualitätstreue, die heute ein elementares, unabdingbares Kriterium der modernen Fertigung ist. Schliesslich ist ein Mehrfachspannsystem mit mehreren unabhängigen Spannstellen auch für den Einsatz in der Serie ideal, da so mehrere Werkstückspannungen mit unterschiedlichen Parametern möglich sind.

## Anwendung ist bei horizontalem und vertikalem Aufbau möglich

Häufig wird bei der Serienfertigung eine Maschine mit horizontalem Aufbau, Palettenbahnhof und Spanntürmen verwendet. Was aber ist mit vertikalen Bearbeitungszentren? Wo liegen hier die Vorteile eines Mehrfachspannsystems? Spanntürme, die in der Serienfertigung mit modularen Mehrfachspannsystemen bestückt werden, weisen eine hohe Spanndichte auf, die zur verlängerten Spindelzeit führt. Gleichzeitig ist auch eine hervorragende Zugänglichkeit der Werkzeuge gewährleistet.



1

## Vertikalmaschinen, deren komplette Tischflächen mit einem modularen Mehrfachspannsystem bestückt sind, ermöglichen Spanndichten, die denen auf Horizontalmaschinen gleichen

Mit einer vierten Achse kann eine Vertikalmaschine zur Serienmaschine mit Mehrseitenbearbeitung aufgerüstet werden, wobei auch hier eine hohe Spanndichte und Zugänglichkeit erreicht wird. Die horizontale und die vertikale Strategie lässt sich mit dem gleichen Spannsystem umsetzen, was bei Maschinenausfall mitunter eine echte Problemlösung darstellt.

## Autarke Spannstellen sind auch für die Kleinserie wichtig

In der Einzelteil- und Kleinserienfertigung spielen modulare Mehrfachspannsysteme grundsätzlich die gleichen Vorteile wie in der Serienfertigung aus: hohe Spanndichte, geringere Werkzeugwechselzeiten, bessere Tischauslastung, gute Zugänglichkeit, einfache Handhabung, einfaches Engineering. Besonders wichtig ist hier jedoch die Flexibilität der Spanntechnik. Gerade bei kleinen Losgrößen geht viel Zeit beim Umrüsten verloren. Um diesen Vorgang zu optimieren, ist der Einsatz modularer Spannsysteme häufig das einzige Mittel. Daher ist die schnelle Verstellbarkeit der einzelnen Spannstellen in Spanndruck, Backenbreite oder Backenausführung unabdingbar.

Autarke Spannstellen sind gerade für den Einzelteilfertiger immens wichtig. Mit ihnen kann er sicherstellen, dass sich verschiedene Werkstücke aus unterschiedlichen Materialien gleichzeitig und prozessspezifisch spannen lassen (siehe Bild 2).

Der notwendige Spanndruck wird dabei ebenso gewährleistet wie die Verformungsfreiheit des Werkstücks. Letztlich resultiert aus der höheren Spanndichte eine längere Spindelzeit. Bei wiederkehrenden Kleinserien ist die reproduzierbare Spannsituation sehr wichtig. Wie in der Grossserie kann auch bei Kleinserien oder Einzelteilen die Tischfläche mit einem Mehrfachspannsystem besser ausgenutzt, der Werkzeugwechsel reduziert und die Wirtschaftlichkeit erhöht werden (siehe Bild 3).

Bei genauer Betrachtung der verschiedenen Fertigungsstrategien - Horizontal- oder Vertikal-BAZ sowie Serien-, Einzelteil- oder Kleinserienfertigung- wird die Vermischung der Verfahren deutlich. Die vermeintlichen Unterschiede sind oft nicht gross. Auch ist die Investition, die beim Übergang von einer Strategie zur anderen notwendig wird, jederzeit vertretbar und zu argumentieren. So erweist sich beispielsweise eine hochwertige Spannschiene mit drei oder vier Spannstellen als weitgehend preisneutral zu einem klassischen Maschinenschraubstock.

Für viele Anwendungen sind modulare Mehrfachspannsysteme ein echter Problemlöser und daher unumgänglich. Dies gilt sowohl für den Einsatz in der Serie als auch in der Einzelteilfertigung. Insofern haben beide Anwender - um zum Anfang zurückzukehren - mit ihrer Sichtweise recht. Nur gelten die Vorteile eben nicht nur für den jeweils anderen Bereich, sondern vor allem auch für den eigenen.

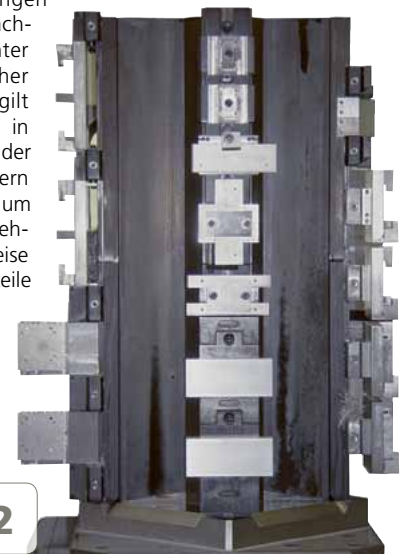

2

**Kleinserienfertigung auf Horizontalmaschinen: Autarke Spannstellen ermöglichen die gleichzeitige, spezifische Fixierung unterschiedlicher Werkstücke.**

*Small batch production of different work pieces on a horizontal machining centre (family of parts)*

# The dormant potential

From the press

Modular and multiple workholding systems are still underestimated in their economic potential. But they have proven their point in many practical applications in batch production, in some cases even on small series. This is due to their modular, compact design resulting in a very high workpiece density. In spite of their compact size, the clamping force is considerable. Producers of small batches see the advantages of these systems mainly in the quantity production, whereas the mass producer uses these modular vice elements on some occasions to quickly set up a fixture for only a few parts. The reason for this fact you will find in this editorial.

## Modular workholding systems are very flexible in their use

For many machining applications the classical machine vice is still the suitable workholding solution. Since the introduction of the CNC machining centres the demand for flexible, modular systems has constantly increased. These systems allow the accommodation of many parts in a limited workspace. Also the number of tool changes are considerably reduced, which means less machining time per part and longer spindle time between the loading stops. Consequently the machine productivity goes up.

Modern multiple workholding systems must be flexible. The setting up of their modules must be simple and quick. The kit like components have to be adaptable to many different workholding configurations, just by placing them into other locations or changing jaws. Their clamping force must be adjustable to protect the workpiece. In the ideal case the base rail must be able to accommodate many different vice modules and jaws.

In the production of larger batches the modular workholding systems have the greatest advantages. Their interchangeable modules can be placed to suit the workpieces often replacing expensive dedicated fixtures. Engineering of fixtures may be simplified.

Hence planning and set up from one part to the next can be shortened. Multiple workholding systems contribute also to more constant and precise parts improving the interchangeability of products, an important criterion in today's industrial world. In some cases it is even possible to clamp a family of parts in one setup. Some of our customers take advantage of this feature.

## Installation possible on horizontal and vertical machines

On horizontal machines tombstones (fixture carrying towers) are often installed on the pallets. This arrangement allows for machining on three faces even with very high workpiece density. What about machines with vertical spindles? Where are the advantages of multiple workholding

systems on such machines. The machine table can be filled with several workholding systems side by side allowing many parts to be clamped in a small area. If an indexer (fourth axis) is installed with a bridge or a trunnion exactly the same machining features are possible as on a horizontal

**The output of a vertical machine with a fully loaded table surface is similar to that of a horizontal machine.**

machines – lots of parts even when machining on three faces. If independent base rails are used they can be installed vertically as well as horizontally. A high interchangeability of components gives good flexibility in case of a machine break down.

## Multiple workholding also for small batch production and families of parts

A very important advantage besides the points mentioned for large quantity production, is the workholding of part families, particularly if the parts are produced at intervals. In such cases the flexibility and the simplicity of set up is of great importance. For instance shaped jaws may be stored in the tool room ready for the next production run. In some applications users build dedicated fixtures and install Compact Clamp or microCLAMP vice modules on their own fixtures (see picture 2).

Naturally the rail based systems like the Power Clamp or the Compact Clamp can be used as a conventional vice if only one vice module and one end module is used. For wider workpieces sometimes two or more systems are installed side by side. Doing that, the vice modules and the reference surfaces are aligned by the serrations or the pins in the base rail.

Again, the clamping of different workpieces allows the use of the same tool on various cuts therefore giving longer machining cycles and less tool changes (see picture 3).

The investment in a multiple workholding system with three or four workholding stations is about the same as that for a conventional machine vice. But the multiple workholding system gives the user much greater flexibility and versatility.



**Die Verwendung von Mehrfachspannsystemen auch in der Kleinserienfertigung reduziert den Werkzeugwechsel und erhöht die Wirtschaftlichkeit.**

**The use of a multiple workholding system is also beneficial in small batch machining.**



Mehrfachspannung auf Sputnik 1  
Multiple workholding on Sputnik 1



# MAKINO a500Z & Sputnik II

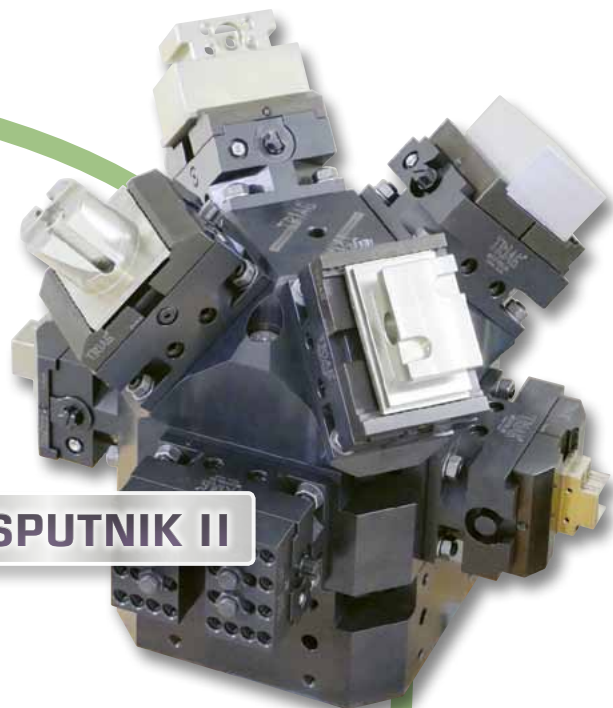

**SPUTNIK II**

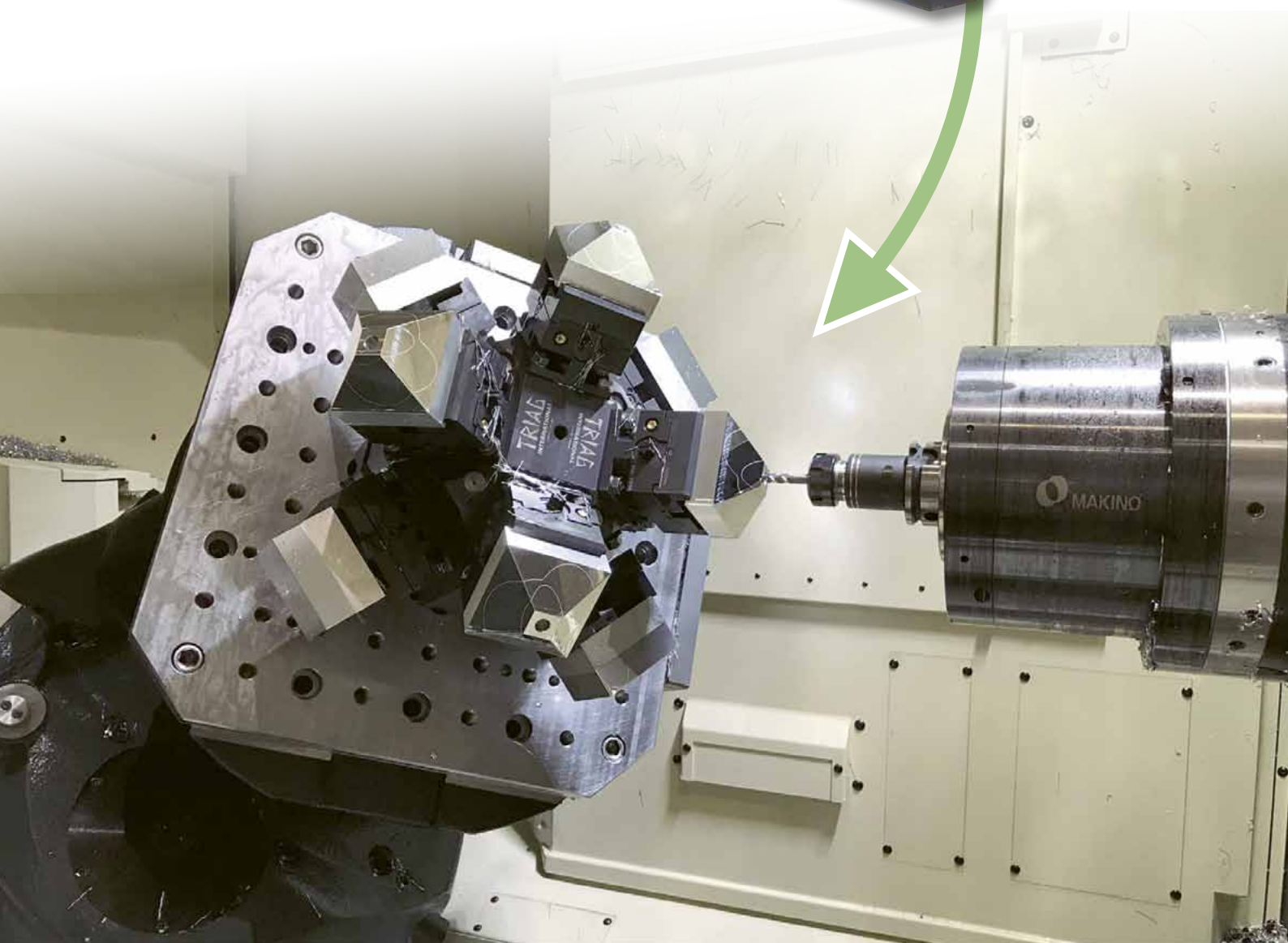

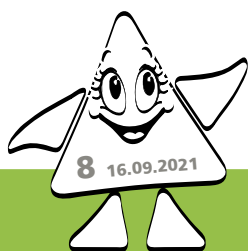



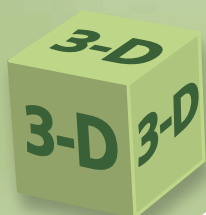
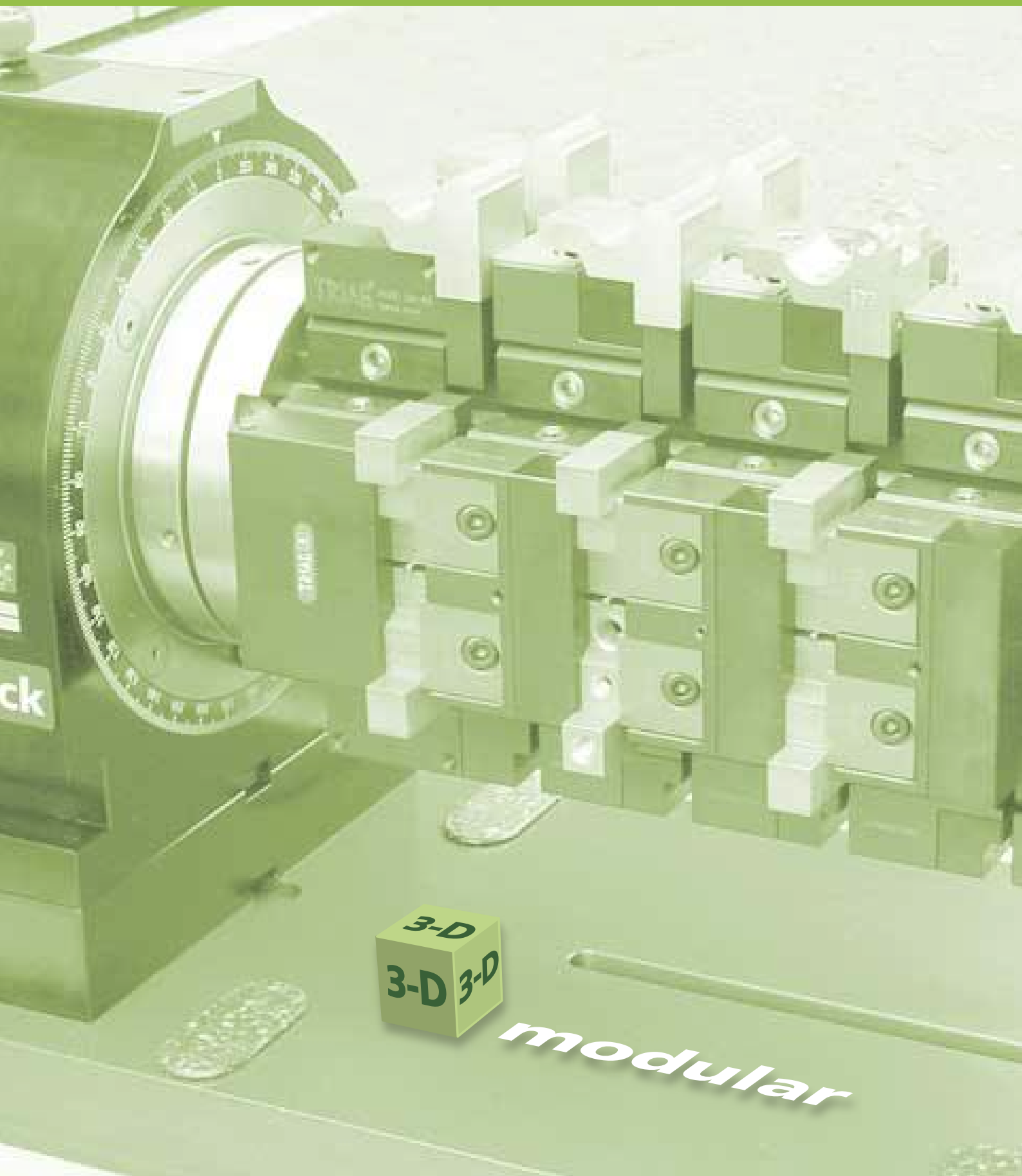





# *power*CLAMP & 5axes

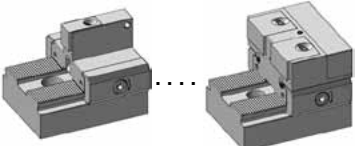
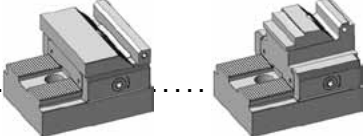

*modular*

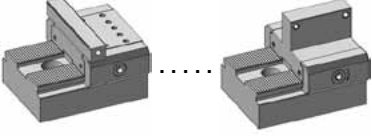

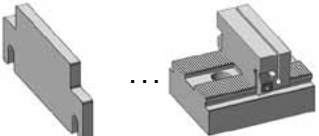
	Einleitung   <i>Introduction</i> .....	15 - 21
	Bedienungsanleitung   <i>Operating manual</i> Spannkraft und Drehmoment   <i>Workholding force and torque</i> .....	22
	Anwendungsbeispiele   <i>Examples of application</i> .....	23 - 38
	System - Basisschiene   <i>System - base-rail</i> .....	 41 - 57
	Modular - Startersets   <i>Modular - Starter kit</i> .....	 58 - 59
	Niederzugspanmodule   <i>Pull down clamp modules</i> .....	 60 - 73
	Linearspanmodule mit Präge- und Linearbacken <i>Linear clamping modules with stamping and linear jaws</i> .....	 74 - 83
	Backen zu Linear   <i>Jaws for linear</i> .....	 82 - 84
	Anschlagmodule   <i>End module</i> .....	 85 - 92
	Verschiedene Module   <i>Different modules</i> .....	 93 - 105
	Zubehör   <i>Accessories</i> .....	 106 - 112





Der klassische Maschinenschraubstock ist für gewisse Zerspanungsarbeiten vielfach die richtige Wahl, obwohl man einen Spannstock ohne Mehrkosten auch mit einem Modularsystem aufbauen kann. Er wird durch die ständig erhöhten Anforderungen an die Prozessoptimierung immer mehr durch modulare Spannsysteme ersetzt.

*The classic machine vise is for some application still a good option, on the other hand can you set up the same with a modular clamp system at not higher costs! Because of always increasing demand and high competition you see more modular systems at endusers places, to keep up with productivity.*

Mit den modularen Systemen wird ein hohes Mass an Flexibilität und grosser Spanndichte erreicht. Dies führt auch bei der Einzelteil- und Kleinserienfertigung zur Senkung der kostenintensiven Nebenzeiten, die einen wichtigen Faktor in der Wertschöpfungskette darstellen. Gegenüber Vorrichtungen ist der Vorteil, dass bei einem modularisiertem Aufbau die Aufspannung aus einem Baukastensystem (also standardisierten Einzelbauteilen) besteht, die kostengünstiger sind und für andere Aufspannungen wiederverwendet werden können. Zudem wird für die 3-Seitenbearbeitung eine gute Zugänglichkeit zum Werkstück gewährleistet.

*With modular clamp system you achieve a high flexibility and also high density of holding workpieces. This brings you big advantages also by producing single parts or small quantities! Compared to dedicated fixtures you can use this vises for many different applications.*

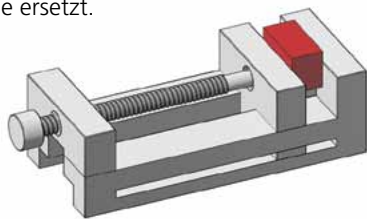

Spannen mit dem Spannstock  
Clamping with the machine vise

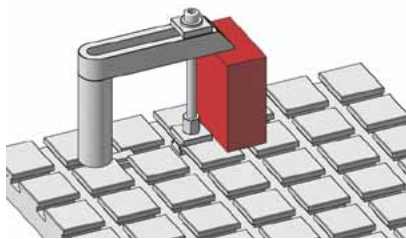

Spannen mit Spannpratzen  
Clamps in operation

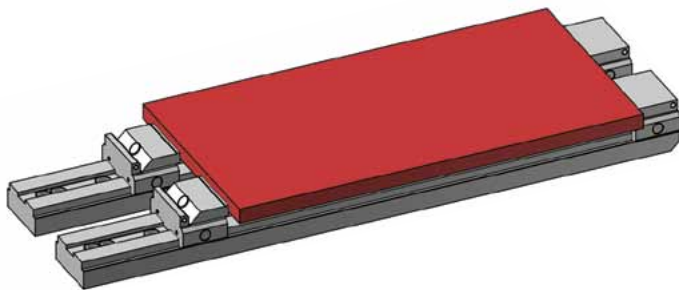
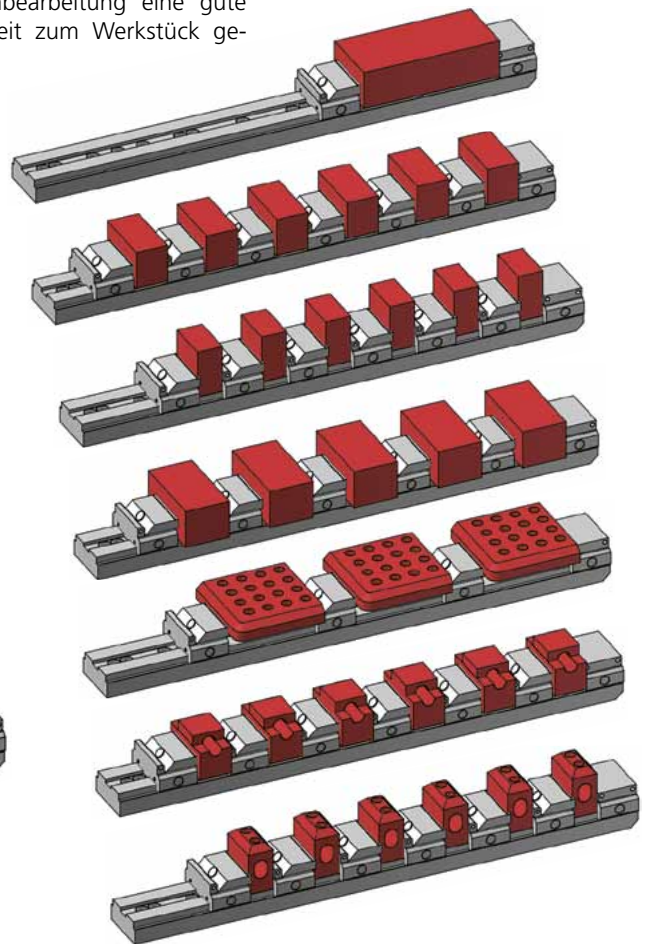

**Ausserdem / And:**

Ich bin auch ein Spannstock!  
I'm also a vise!



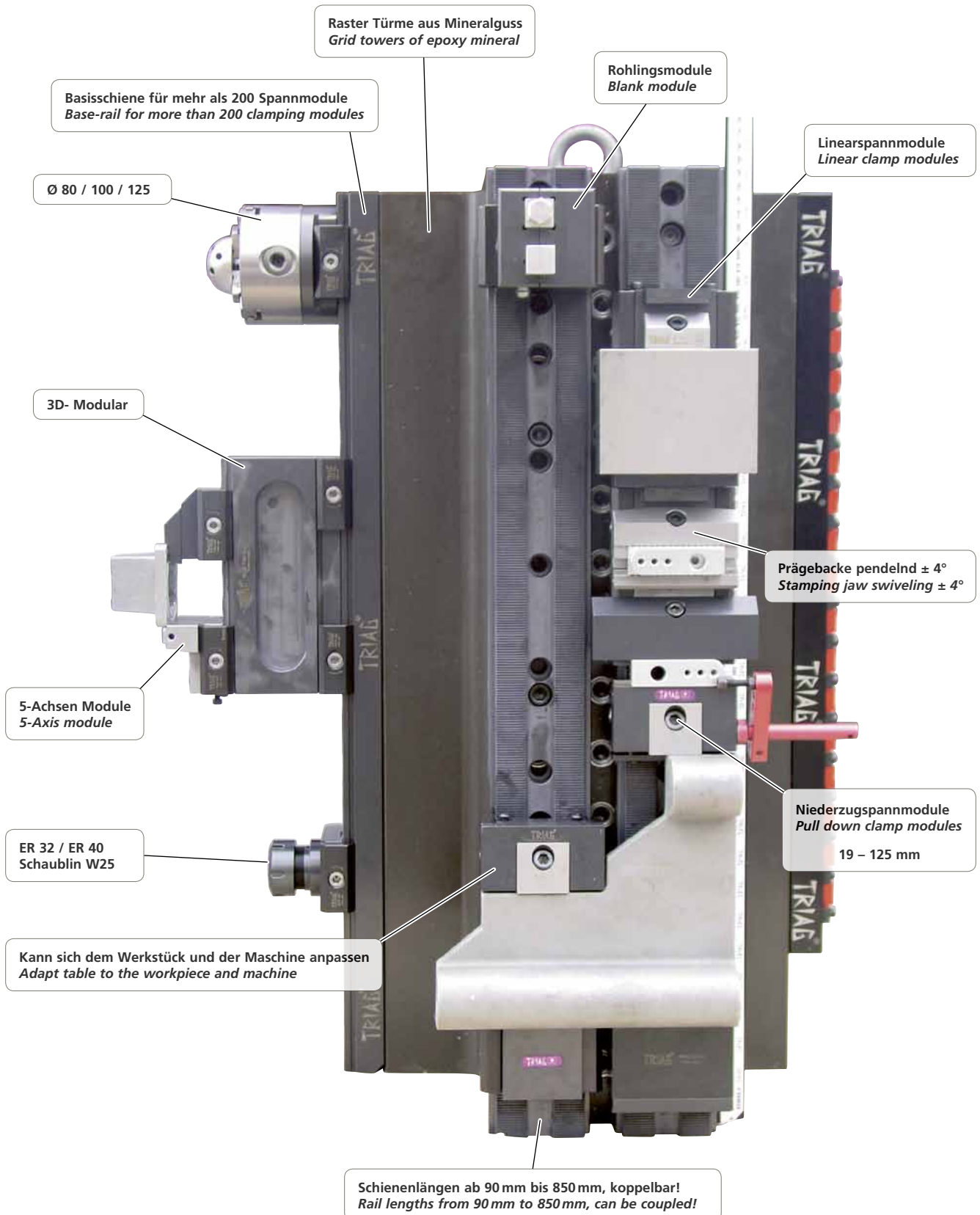

**Modulares Spannen =** Einzelspannung, Mehrfachspannung sowie auch das Spannen von kleinen, grossen oder unförmigen Werkstücken.  
Chaotisches, gemischtes spannen!

**Modular workholding =** Single clamping, multiple clamping small parts and large workpieces can be clamped, also shaped parts are possible to clamp.  
Mixed setups in chaotical clamp situation!



Mit dem Spannsystem Power Clamp hat die Triag International ein Produkt entwickelt, welches die Vorteile des klassischen Maschinenschraubstocks mit der Modularität eines innovativen Spannsystems in einer optimalen Art und Weise kombiniert und eine enorme Vielseitigkeit bietet. Einfache Spannungen sind genauso möglich wie Mehrfachspannungen und Spannungen von schwierigen Werkstücken.

*With Power Clamp Triag has developed a product which includes the advantages of a classical vise and has the features of an advanced modular system. It can be used to clamp single parts (small and big) or multiple workholding as well as difficult to clamp parts.*

## Schnelligkeit / Quickness



1

**Eine Schraube lösen**  
*Loosen a screw*



2

**Abheben und neu platzieren**  
*lift and change position*



3

**Eine Schraube anziehen**  
*fasten one screw*

Mit nur einer Schraubspindel, welche von beiden Seiten her zugänglich ist, werden die positionierten Module in einem patentierten Prätzensystem zuverlässig geklemmt.

Die Module können an jeder Stelle der Trägerschienen aufgesetzt werden. Verglichen mit dem üblichen axialen Aufchieben beschleunigt das den Aufbau von Mehrfachspannern und ermöglicht, diese Spannsysteme auch bei beengten Platzverhältnissen komfortabel zu rüsten.

*With only one bolt screw (left and right hand thread) the clamp modules can be lifted and change position in 2mm steps.*

*This patented system is unique and fast, as well as accurate.*



4

**Drehmoment beachten**  
*Observe the torque*

## Geringes Gewicht Low weight



**= Einfaches Handling**  
**= Easy handling**

Das Modul kann mit zwei Fingern abgehoben werden.  
*The clamp module can be moved by two fingers.*



Darum haben wir dieses Symbol gewählt:  
*Thats why we have chosen this symbol:*



## Einfache Reinigung Easy cleaning

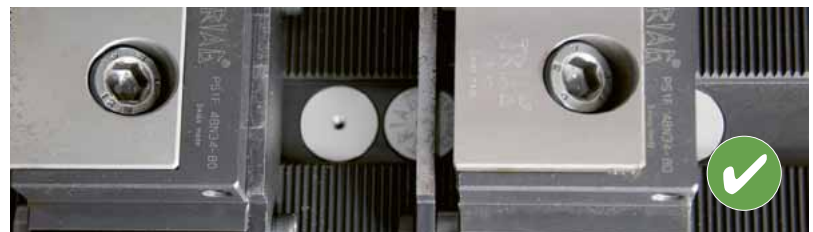

Keine spänefüllenden T-Nuten (im Gegensatz zu vielen Wettbewerbsprodukten) - Basis bilden stabile, mit Teilstücken verlängerbare Trägerschienen. Sie verfügen über eine hochgenau gefräste Verzahnung.

Eine Vielzahl an Spannmodulen mit unterschiedlichen Spannelementen lassen sich auf den Trägerschienen in einem Raster von 2 mm positionieren.

*No chip catching T slots (opposite of many competitors). The base rails are rigid and can be used modular in length width and hight. The serration is accurate and checked for each base rail.*

*Many different clamp modules can be used on only one type base rail (step 2 mm)*



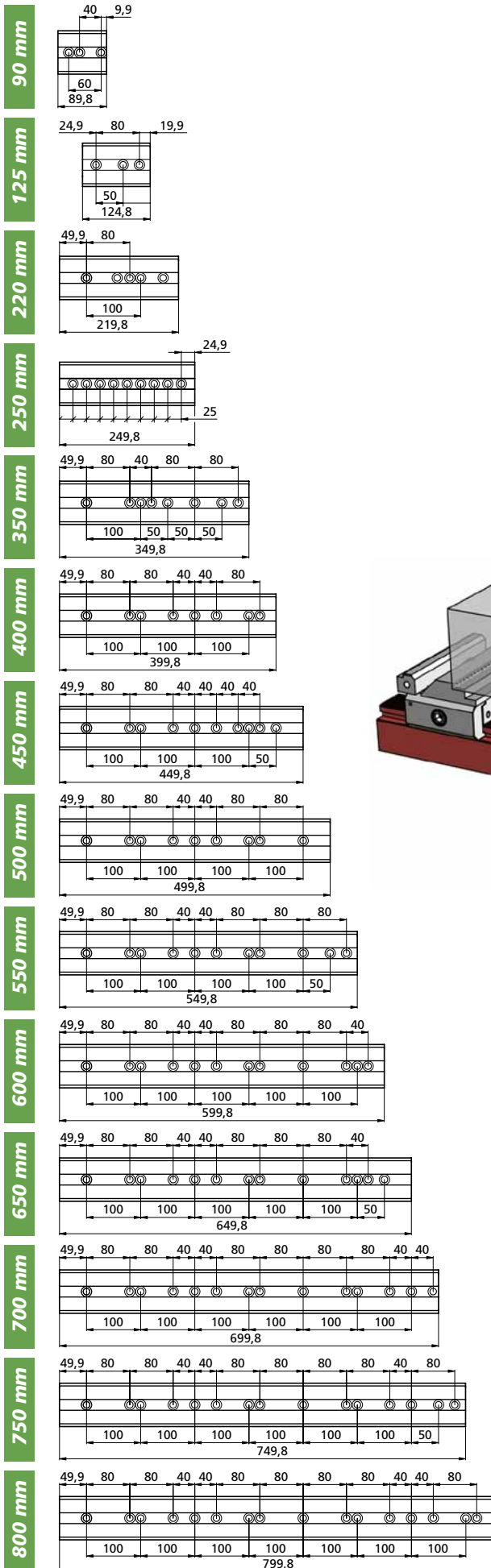

Schienen sind in den folgenden Höhen lieferbar:  
 Rails are in following ups available:

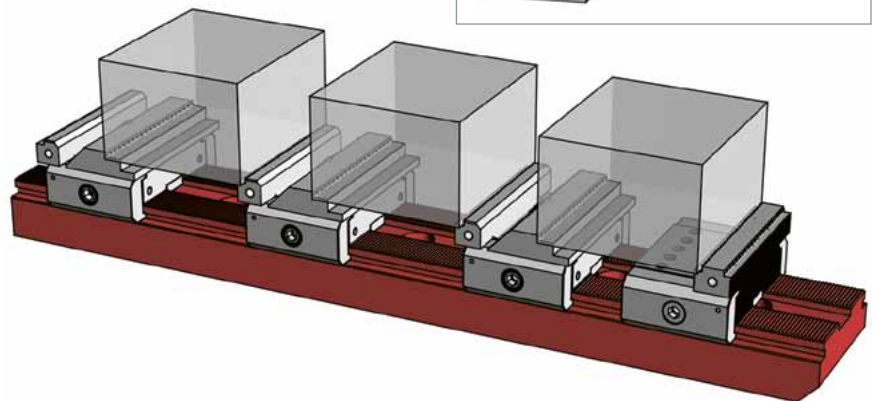
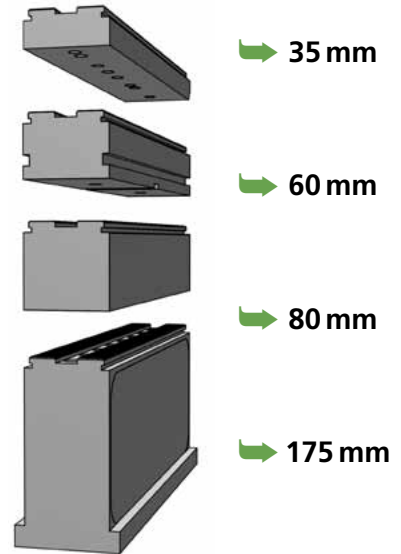

## Basisschiene

Die Basisschiene ist das Grundelement des modularen Spannsystems von Triag International und ist in den Höhen 35 mm, 60 mm, 80 mm und 175 mm verfügbar. Auf der Basisschiene werden alle Spann- und Anschlagmodule über eine Schraubspindel mit einer Haltekraft von 15.000 daN (= 15t) befestigt. Eine schnelle und genaue Positionierung ist durch die Verzahnung (2 mm Teilung) auf der Basisschiene gewährleistet und sorgt somit für kurze Rüstzeiten.

Durch den Einsatz von Erhöhungsmodulen wird die Werkstück-Zugänglichkeit speziell bei 5-Achsenmaschinen auch mit kurzen Werkzeugaufnahmen ermöglicht. Somit ist die Maximalgröße der Werkstücke nur noch durch die Maschinengröße eingeschränkt. Die Basisschiene dient in diesem Zusammenhang als mechanisches Nullpunktsystem.

Die Basisschienen sind für eine schnelle Aufspannung auf den gängigsten Palettsystemen konzipiert. Aus Gewichtsgründen können auch die eigens entwickelten Spanntürme aus Mineralguss eingesetzt werden. Diese verfügen über eine so hohe Vibrationsdämpfung, dass dadurch im oberen Bereich der Türme sehr präzise gearbeitet und dabei eine exzellente Oberflächengüte erreicht werden kann.



Mit verschiedenen Basismodulen kann man auch die 3. Dimension Modular gestalten! Mit der Höhe von 60 mm kann die Modulhöhe auf 94 respektive auf 109 mm erhöht werden (34/49 Modulhöhe). Die Länge von 130 mm erlaubt es jeweils ein Spannmodul und ein Anschlagmodul zu platzieren.

There are different sizes of riser blocks to increase the height of the clamp modules. This way you can get from 34 to a clamp height of 94 or 109 mm depending on the clamp module you choose. This riser blocks makes the power clamp system 3D-modular!

**Mehr auf Seite | More on Page 48**

## Base rail

The base rail is the basic element of the Triag modular clamp system. We offer them in different lengths and heights and more than a hundred different standard clamp modules will fit onto the base rails.

Holding force which the clamp modules are clamped to the base rail is 15'000 daN (15t). The precision serration in 2mm pitch allows to fit the clamps fast and accurate.

All three dimension are modular! You can double or triple the length with coupling the rails or you can use them side words in a row. Also the height is modular (please see next page)



Basisschienen in Zoll  
Base rails in inch

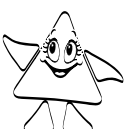



## Das Anschlagmodul / End modules

Für das Spannsystem «Power Clamp» ist in der Regel nur ein Anschlagmodul als «feste Backe» notwendig. Mittels der 2 mm Verzahnung lässt sich das Modul sehr genau auf der Basisschiene positionieren und ist mit der Schraubspindel schnell befestigt.

Für die unterschiedlichen Bearbeitungssituationen steht eine Vielzahl von Ausführungen zur Verfügung. Diese unterscheiden sich in der Breite der Backen (ab 19 mm bis max. 150 mm) als auch in der Beschaffenheit der Spannflächen (glatt, geriffelt, gerillt, hartmetallbeschichtet oder mit Prägeverzahnung, mit der direkt geprägt werden kann).

*In a row of parts there is usually one end module followed by the clamp modules. For all the different clamp situation we offer a wide range of different end modules from 19 mm to 150 mm.*

*Usually you have one side of the datum face flat and the opposite double serrated so you have two options in one. Also direct stamping end modules with a workholding step of 3 mm are available.*

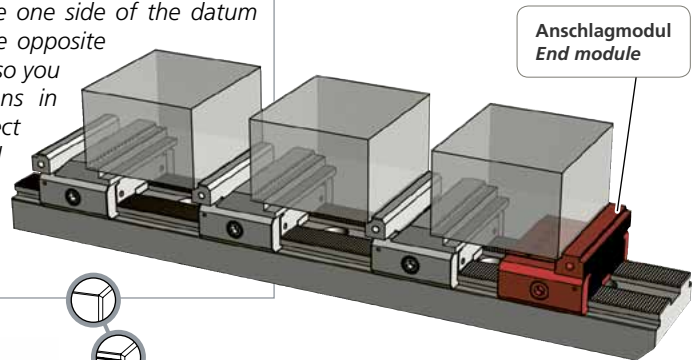

Anschlagmodul  
End module

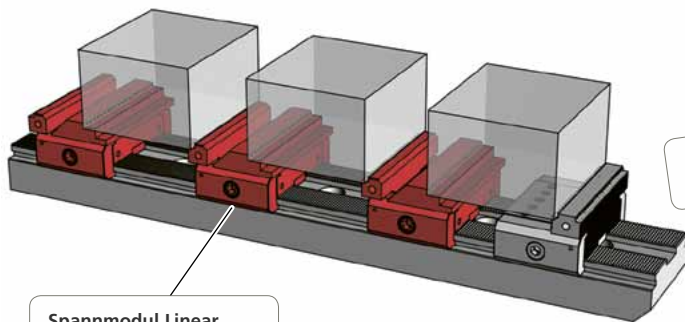

Spannmodul Linear  
Linear clamping module

Verschiedene Ausführungen der Anschlagflächen!  
Different styles at grip surfaces!

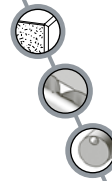

## Das Spannmodul / Clamp modules

Die «beweglichen Backen» gibt es in zwei Ausführungen. Zum einen für das Niederzugspannsystem und zum anderen für das Linearspannsystem. Dabei dient das Spannmodul bei beiden Systemen wiederum als Anschlagmodul für die nächste Aufspannung.

Die Breite der Spannfläche bewegt sich wie bei den Anschlagmodulen im Bereich zwischen 19 mm und 125 mm. Durch die innovativen Ausführungen der Spannflächen wie z. B. die Prägebacken oder Druckstifte werden enorme Haltekräfte erreicht.

Bei umfangreichen Testreihen zu der Werkstückverschiebung bei einer Spannkraft von 2000 daN und einer Zerspankraft von bis zu 600 daN wurden bei der Verwendung von Prägebacken nur minimale Abweichungen vom Nullpunkt festgestellt. Leichte Abweichungen von der Parallelität der Werkstücke werden mit der Pendelfunktion ( $\pm 4^\circ$ ) ausgeglichen.

Innovative Lösungen gibt es auch für spezielle Spannaufgaben, wie z.B. Formbacken, Dreibacken- und Spannanzgenfutter, Vakuumplatten oder Magnetspannplatten.

*There are mainly two different types of clamp modules. Linear and pull down jaws both with integrated datum face for the next workpiece. Datum face can normally be double serrated or flat.*

*The movable jaws you can get in various versions such as hardened flat, carbide coated soft jaws double serrated, linear pull down, direct stamping dovating and more. The width of the clamps modules starts from 19 mm up to 125 mm.*

*Clamping force goes to a maximum of 2800 daN (2,8t).*

*For special clamping situations we offer also chucks, collet chucks vacuum plates or even magnet plates which fits onto the Power Clamp base rails.*



Lineare Direktprägespannung  
Linear direct stamping module





**Niederzugspanmodule**  
*Pull down clamp modules*

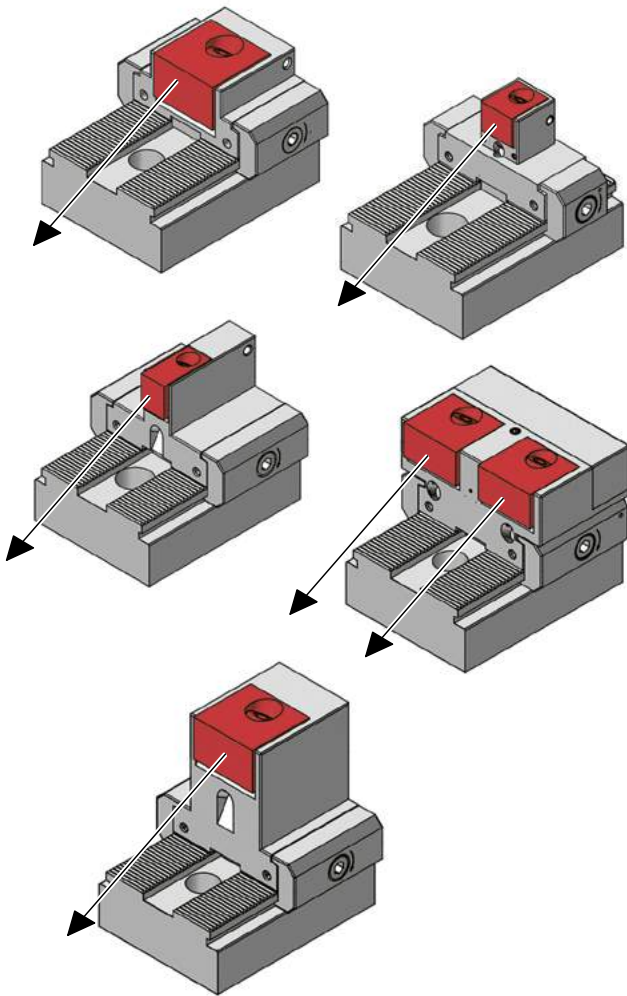

**Die Fakten beim Niederzugspannsystem**

Verstellbereich: 0- 4,1 mm  
 Spannkraft: Bis 2'800 daN

**Vorteile beim Niederzugspannsystem:**

- Höhere Haltekräfte
- Hohe Wiederholgenauigkeit
- Optimale Spannmethode für Kleinteile
- Mit Schnellwechselbacken
- Doppelspannsystem in einer Backe zum Spannen und Bearbeiten von zwei Kleinteilen
- Mit Vorsatz als Linearspannsystem einsetzbar
- Auch Anschläge mit Niederzugeffekt erhältlich

**Facts for pull down clamp modules**

Jaw range: 0- 4,1 mm  
 Clamping force: up to 2'800 daN

**Advantages pull down jaws:**

- Higher holding force
- With linear adaptable jaws
- Also with pull down jaws for the stop side available
- With adapter set can be changed to linear
- Also pull down jaws for datum face

**Linearspanmodule**  
*Linear clamp modules*

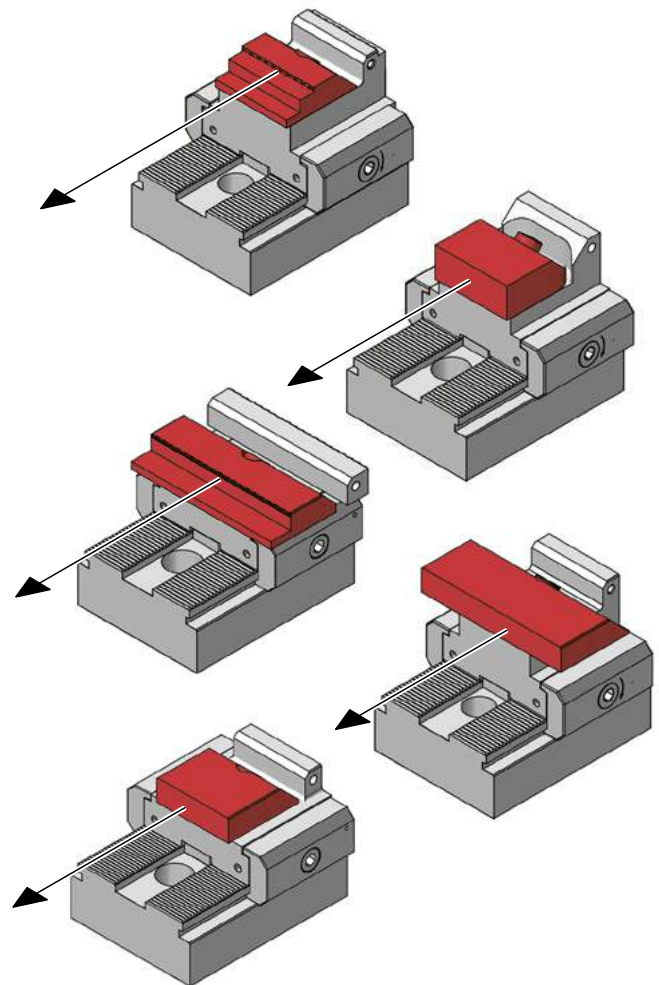

**Die Fakten beim Linearspannsystem**

Verstellbereich: 0- 5,0 mm  
 Spannkraft: Bis 1'600 daN

**Vorteile beim Linearspannsystem:**

- Spannstockähnliches Spannen
- Prozesssichere Positionierung der zweiten Aufspannung
- Gut geeignet für die Erstellung von individuellen Formbacken
- Sicherer Halt mit Prägetechnik

**Facts for linear clamp modules**

Jaw range: 0- 5,0 mm  
 Clamping force: up to 1'600 daN

**Advantages linear jaws:**

- Similar clamp as conventional vise
- Good for shaped jaws
- Secure clamped with direct stamping jaws
- Higher accuracy



**ACHTUNG / CAUTION**

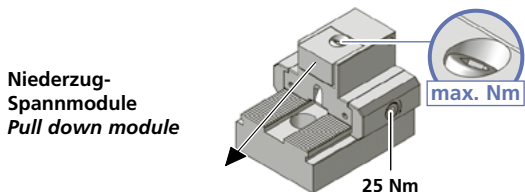

Niederzug-Spannmodule  
Pull down module

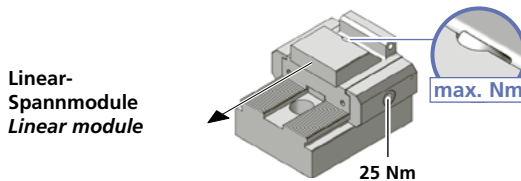

Linear-Spannmodule  
Linear module

Schraube Screw	Drehmoment Torque		Spannkraft Workholding force		
	Nm	(lb-ft)	~daN	~(lb)	~t
M5 + M6	4	3	= 500	1100	0,50
	5	3,7	= 580	1280	0,58
	6	4,4	= 690	1520	0,69
	7	5,2	= 780	1720	0,78
	8	5,9	= 880	1940	0,88
	9	6,6	= 980	2160	0,98
M6	10	7,4	= 1020	2250	1,02
	12	8,9	= 1220	2690	1,22
	14	10,4	= 1450	3200	1,45
M8	15	11	= 1520	3350	1,52
	4	3	= 410	900	0,41
	5	3,7	= 490	1080	0,49
	6	4,4	= 560	1230	0,56
	7	5,2	= 660	1450	0,66
	8	5,9	= 730	1600	0,73
	9	6,6	= 810	1790	0,81
	10	7,4	= 900	1980	0,90
	15	11	= 1520	3350	1,52
	20	14,8	= 1810	3990	1,81
M10	25	18,4	= 2100	4630	2,10
	10	7,4	= 400	880	0,40
	20	14,8	= 1400	3090	1,40
	30	22,1	= 2000	4410	2,00
	40	29,5	= 2800	6170	2,80

Schraube Screw	Drehmoment Torque		Spannkraft Workholding force		
	Nm	(lb-ft)	~daN	~(lb)	~t
M8	10	7,4	= 400	880	0,4
	20	14,8	= 800	1760	0,8
	30	22,2	= 1200	2650	1,2
	40	29,6	= 1600	3530	1,6

**WICHTIG:** Die angegebenen Drehmomente sind die absoluten Maximalwerte. Über die Spannkräfte geben die Tabellen Auskunft.

**IMPORTANT:** The torque numbers specified represent the absolute maximum. The table at the bottom of this page provides further information on the workholding forces.

Die Spannbacken und Schrauben regelmässig fetten!  
 Lubricate clamping jaw and screw regularly with grease!

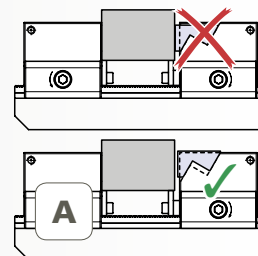
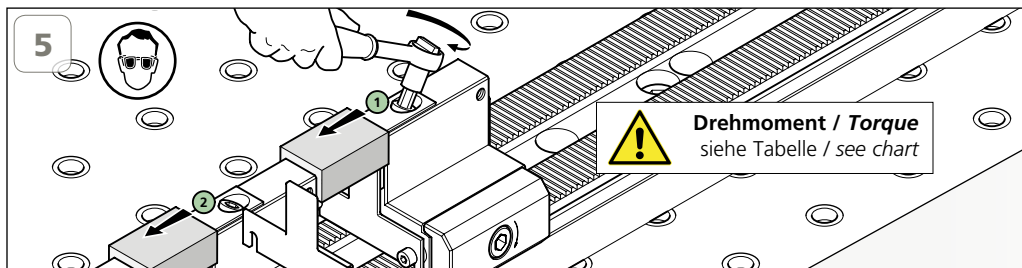
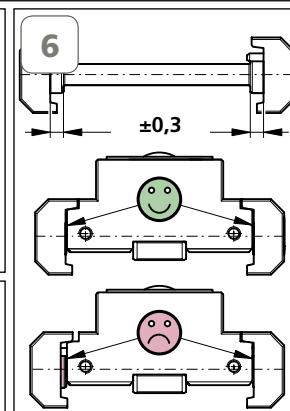
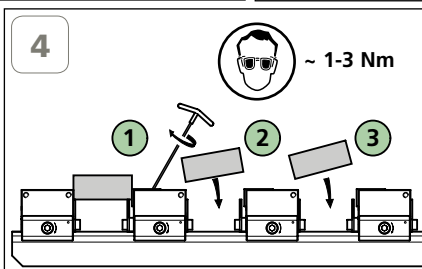
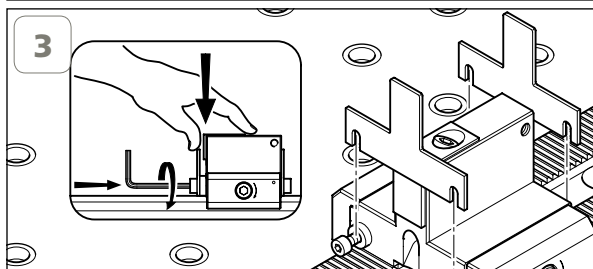
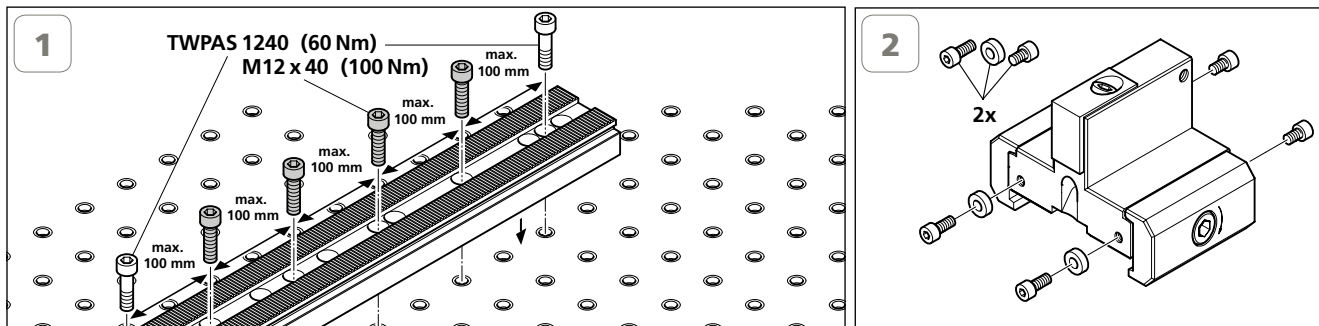
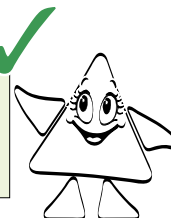

**WICHTIG:** Vor dem Positionieren der Spannmodule für ein neues Werkstück, ist die Spannbacke ganz zurück zu stellen, dies gewährleistet eine sichere Spannung (siehe Bild A)!

**IMPORTANT:** Prior to setting up a new clamping module the clamping jaw of the vice module must be retracted all the way (see picture A)! This guarantees proper clamping of the new workpiece.



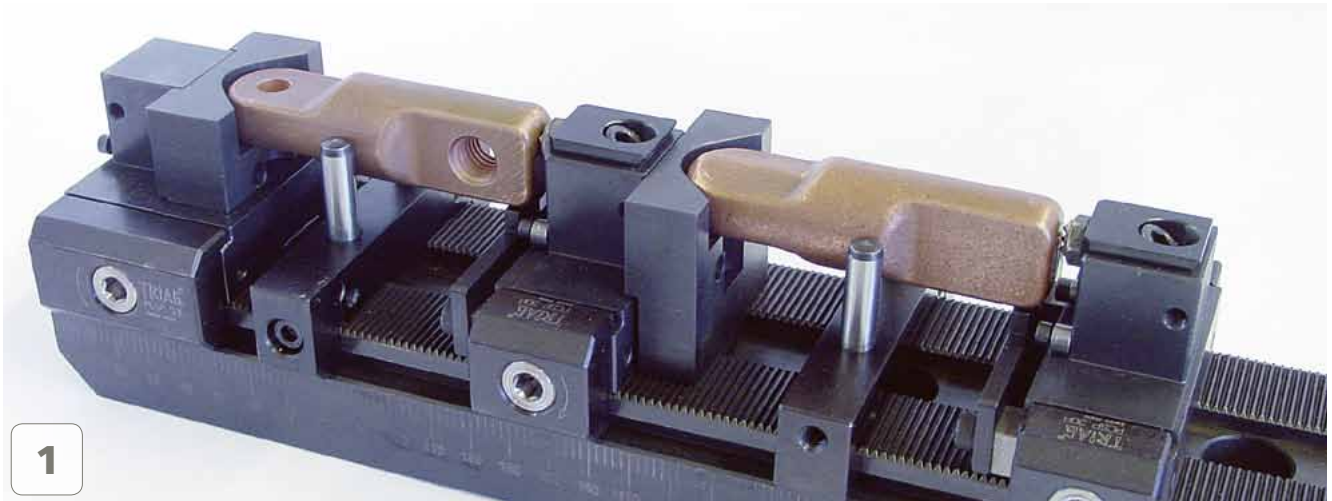

1

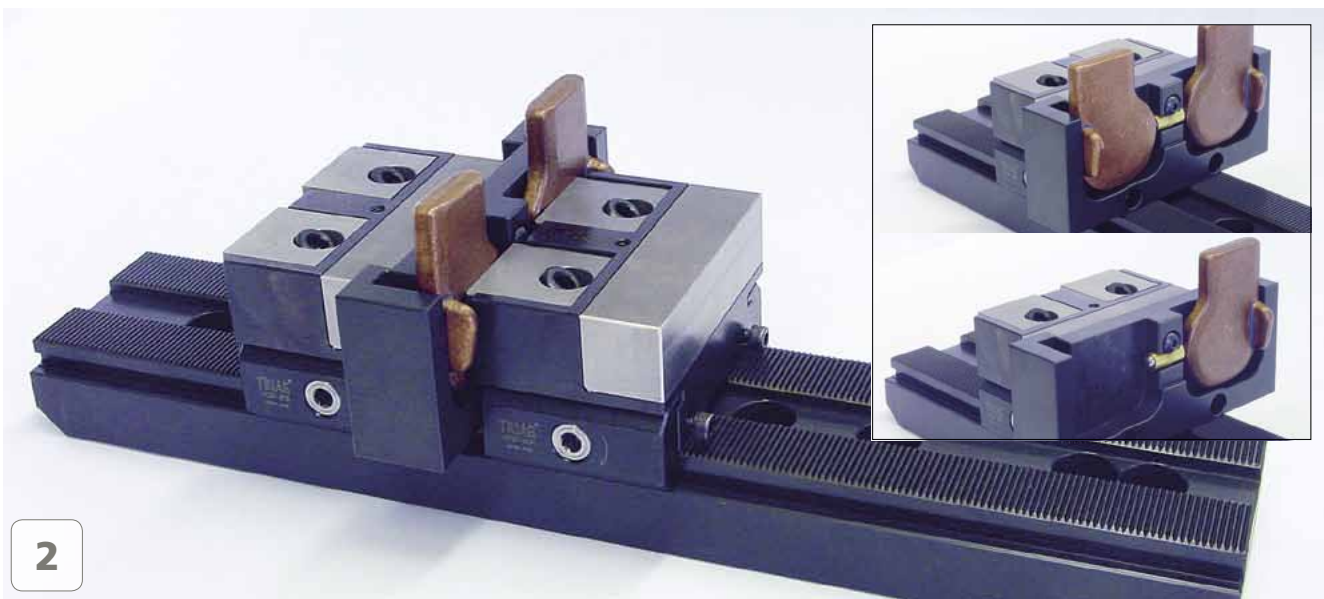

2

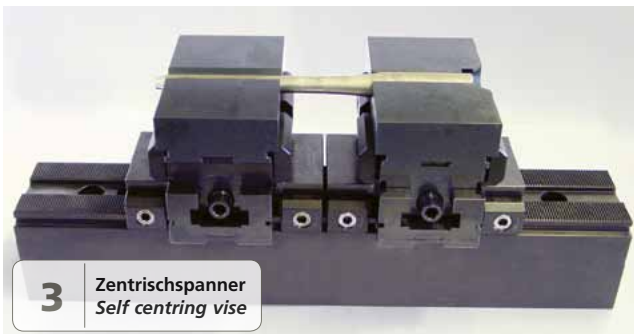

3 Zentrischspanner  
Self centring vise

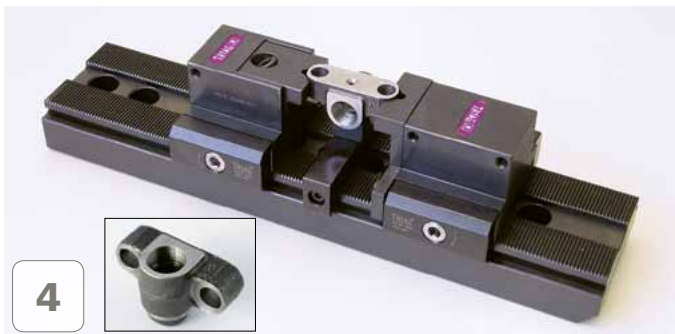

4



5



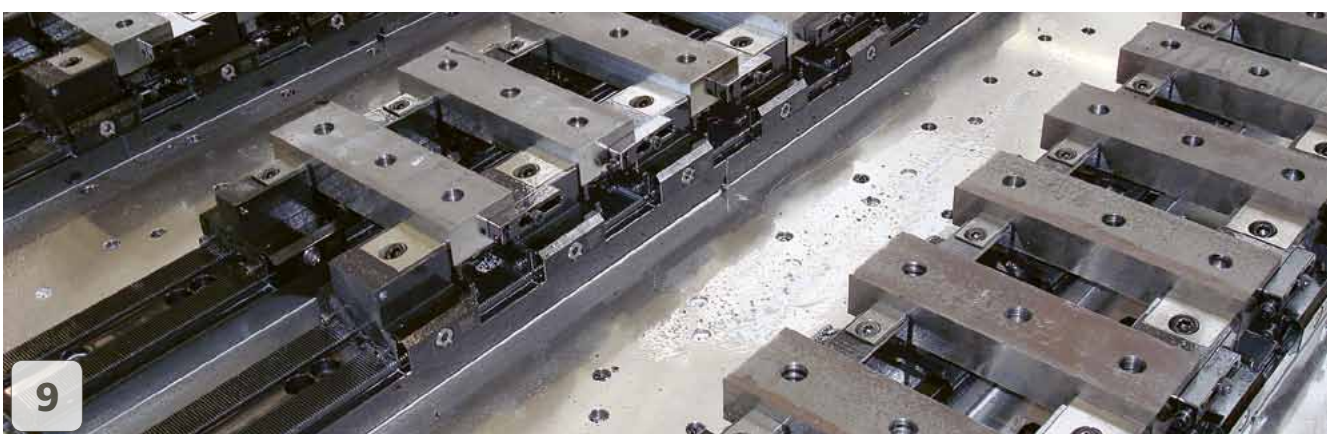
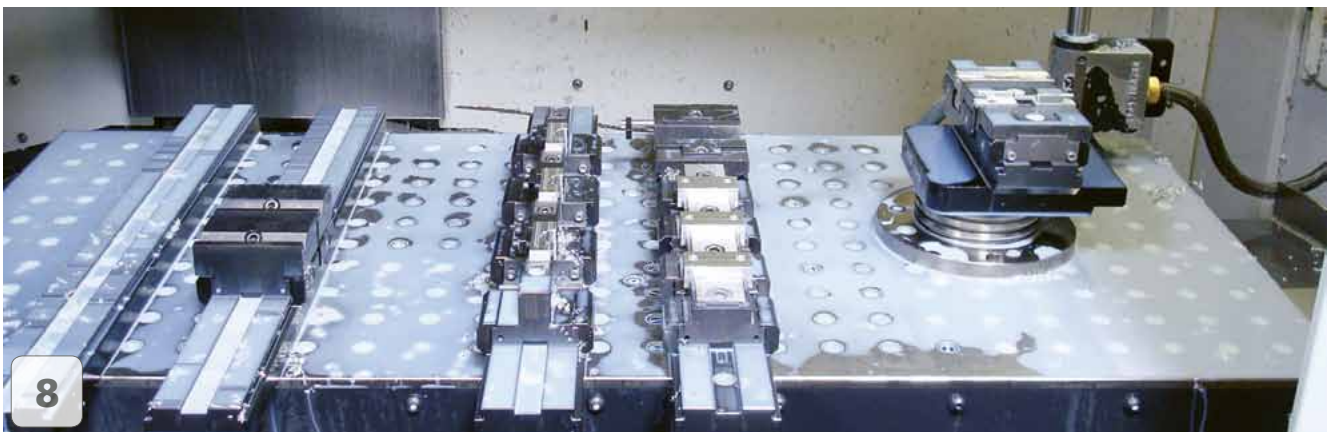
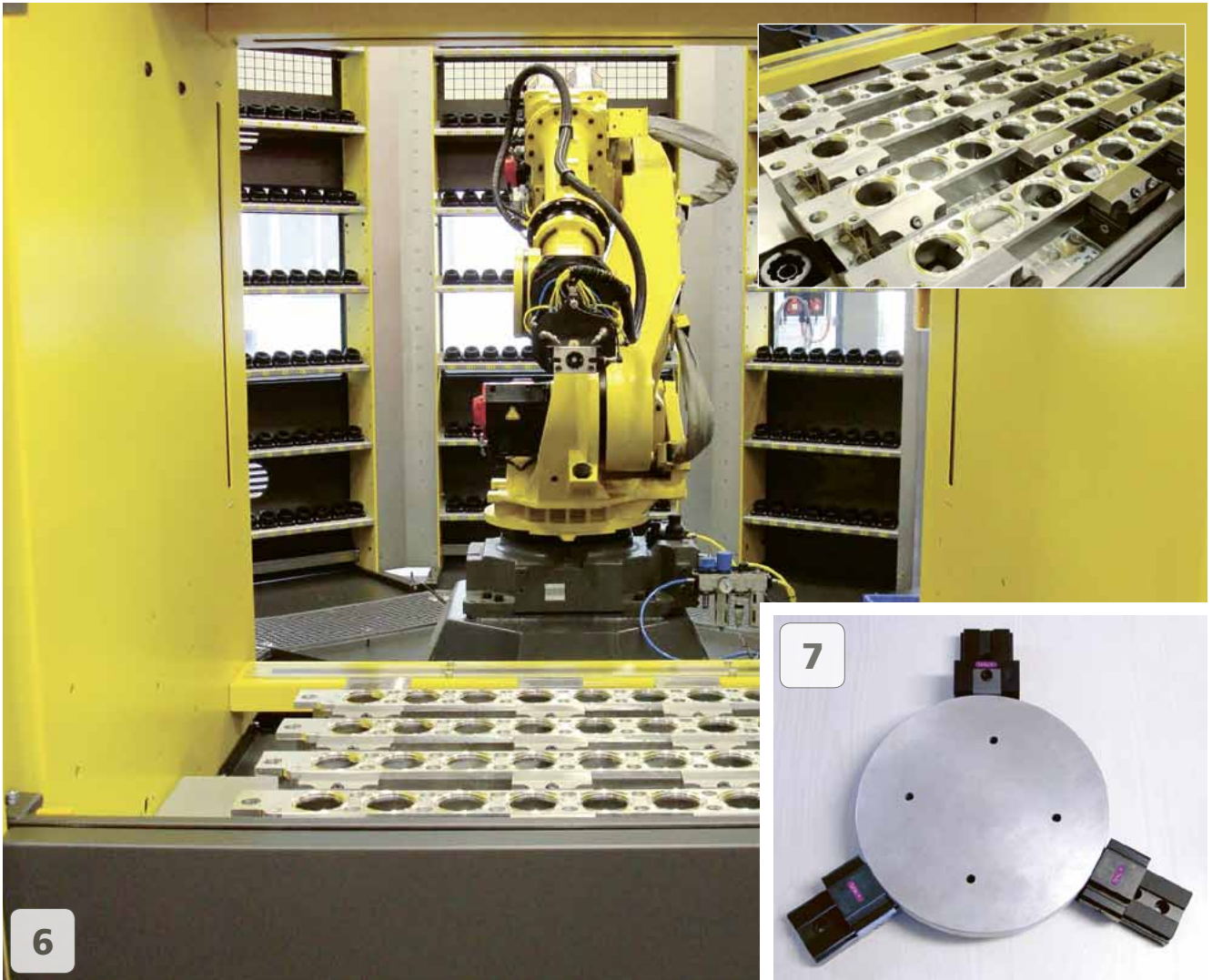



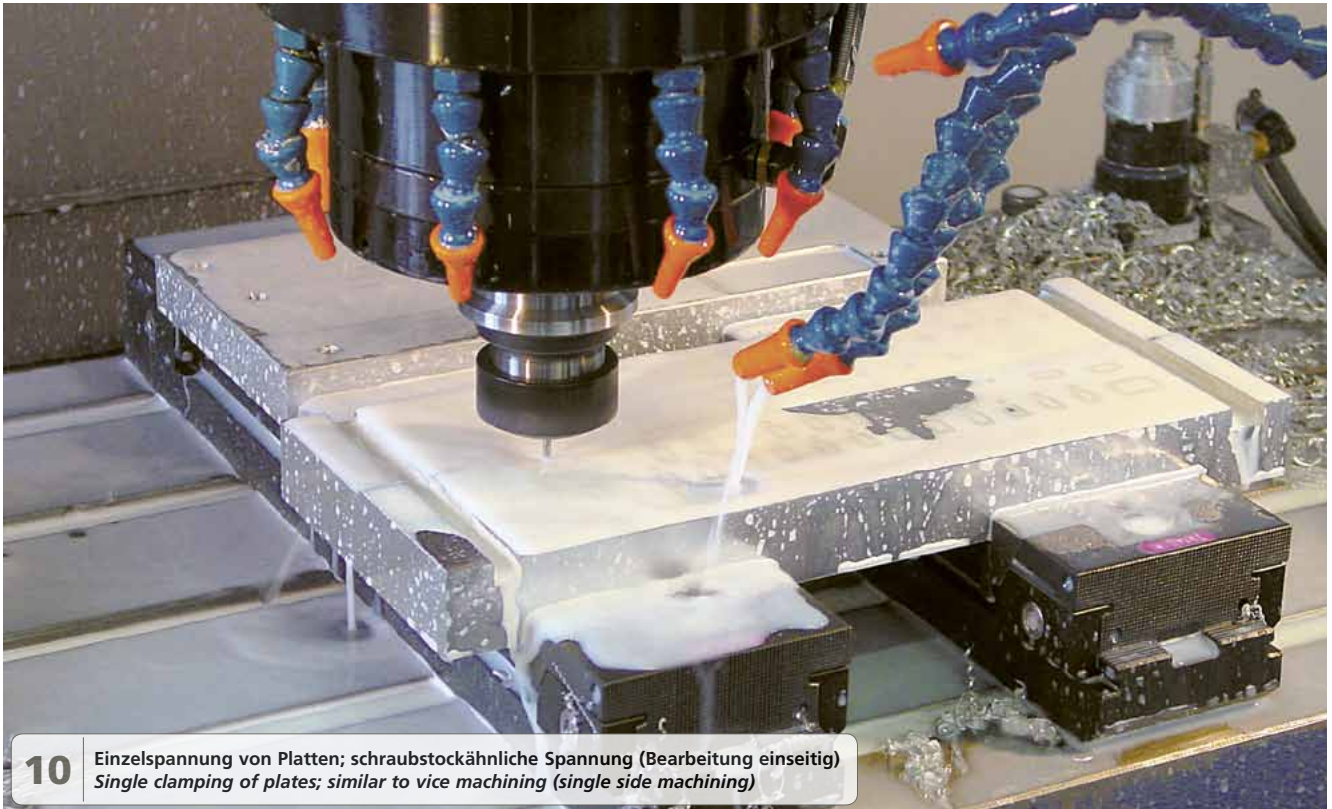

10 Einzelspannung von Platten; schraubstockähnliche Spannung (Bearbeitung einseitig)  
Single clamping of plates; similar to vice machining (single side machining)



11



12 Verschiedene dringende Werkstücke in Bearbeitung, Grundplatte, Nutensteine und Keile (Total 9 Werkstücke)  
Various urgent work pieces in progress, base plate, nuts and wedges (totally 9 pieces)



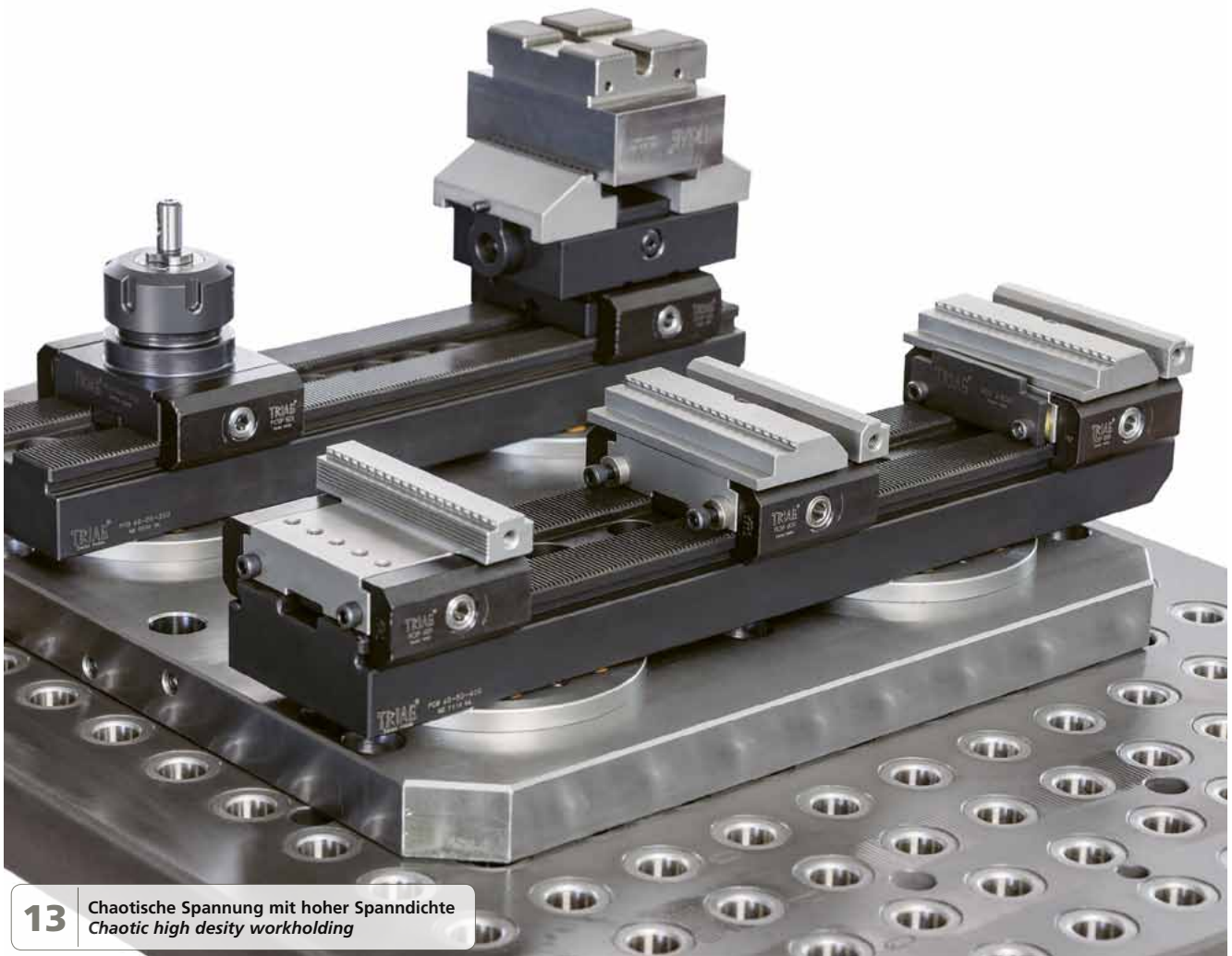

13 Chaotische Spannung mit hoher Spanndichte  
Chaotic high density workholding



14 Chaotische Spannung mit hoher Spanndichte  
Chaotic high density workholding





**15** Prägespannung auf sehr kleiner Einspannhöhe von 3 mm  
Clamped 3 mm depth with direct stamping jaws



**16** Dreiseitenbearbeitung ab 19 mm  
Three-sided machining beginning at 19 mm



**17** ... im Einsatz auf der 4. Achse  
... in action on the 4th axis



**18** Das Triag Power Clamp im Einsatz als Spannstock (Starterset)  
Triag Power Clamp in action as machine vise (starter set)

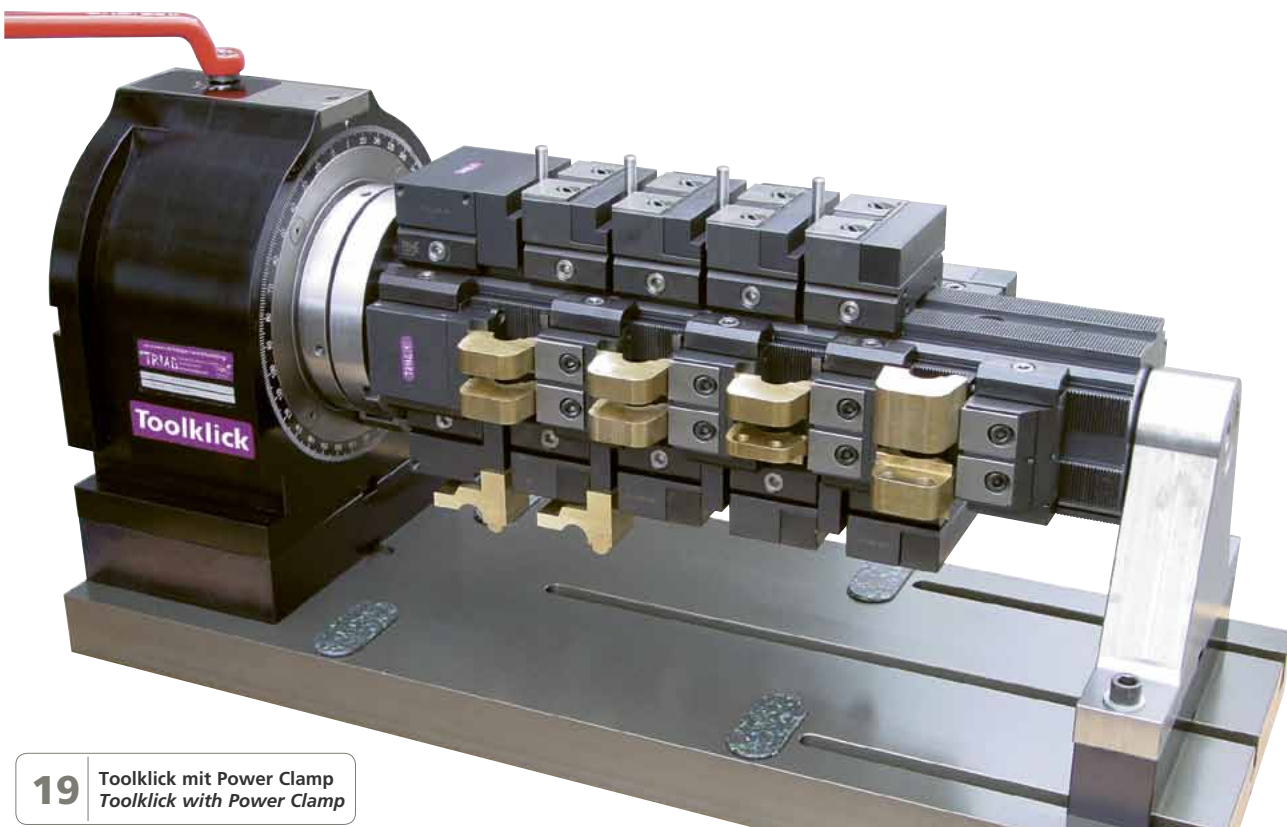

**19** Toolclick mit Power Clamp  
Toolclick with Power Clamp





**20** 5-Achs Anwendung auf Lehmann Teilapparat  
5-axis application on Lehmann indexer



**21**



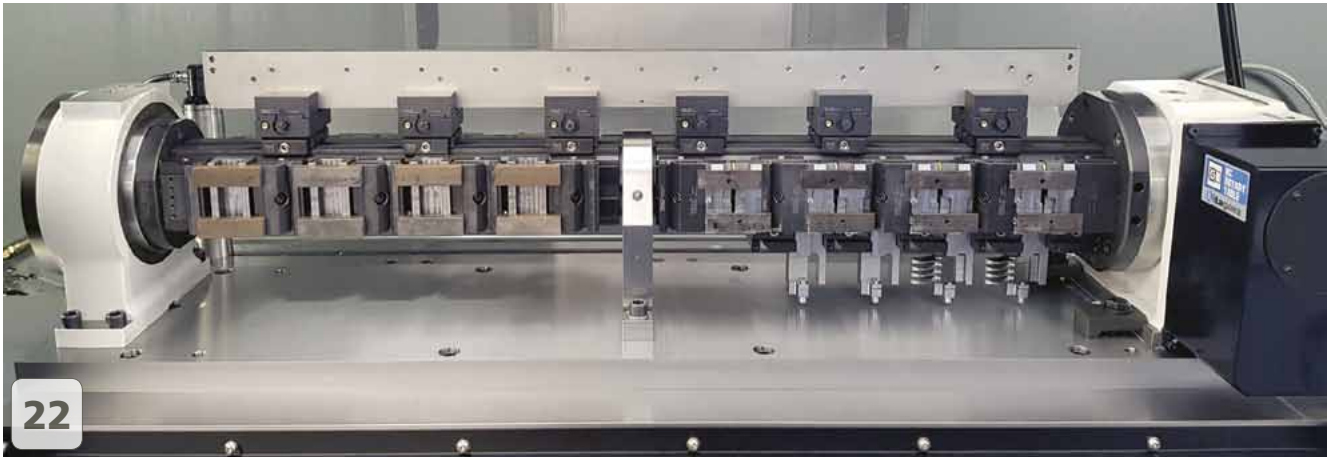

22

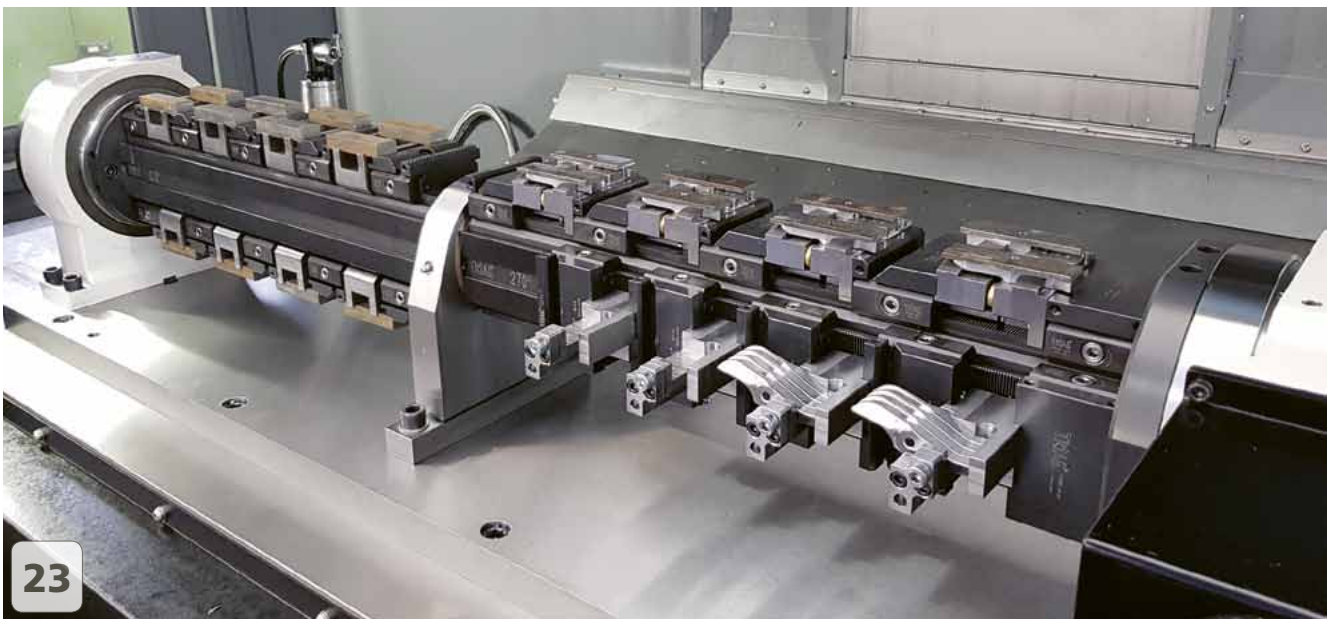

23

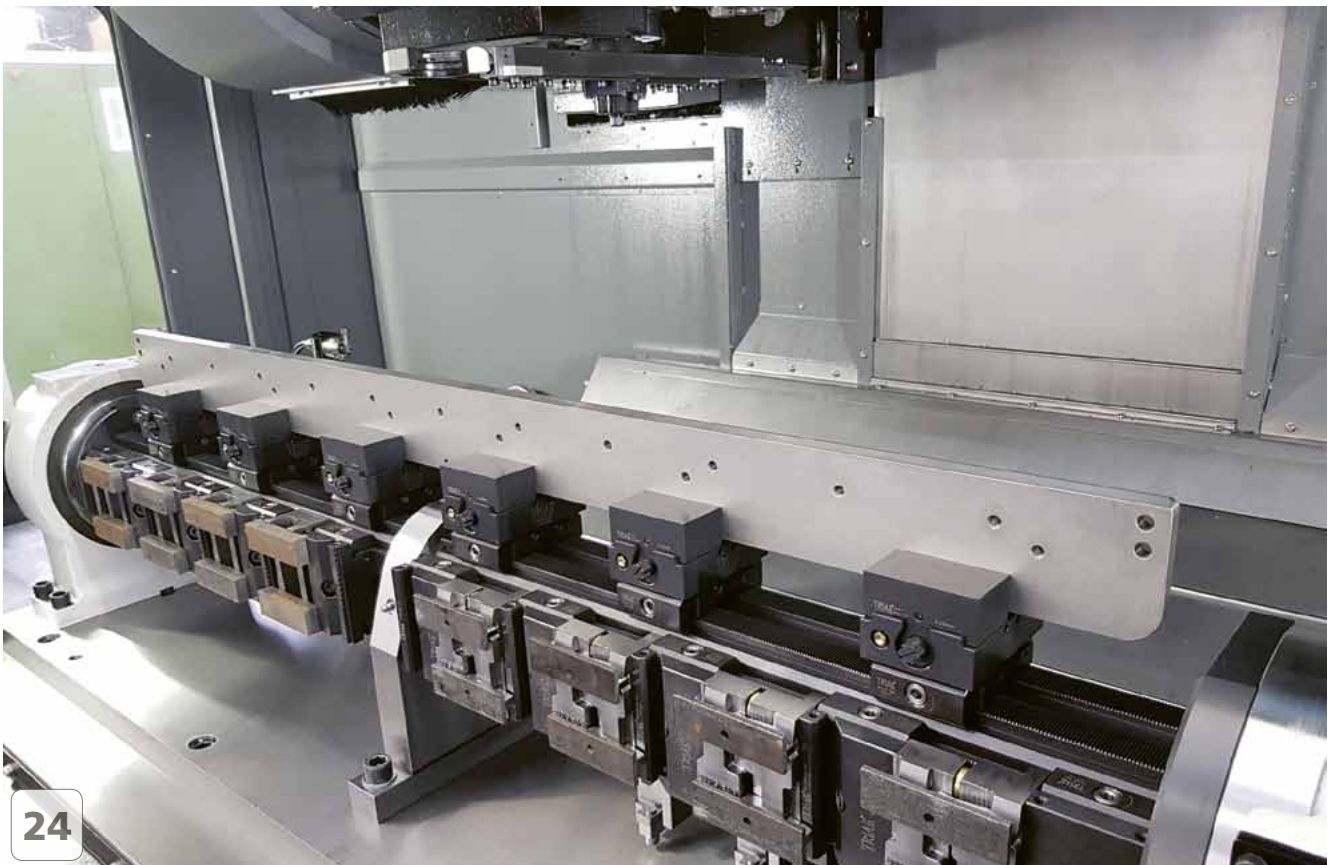

24



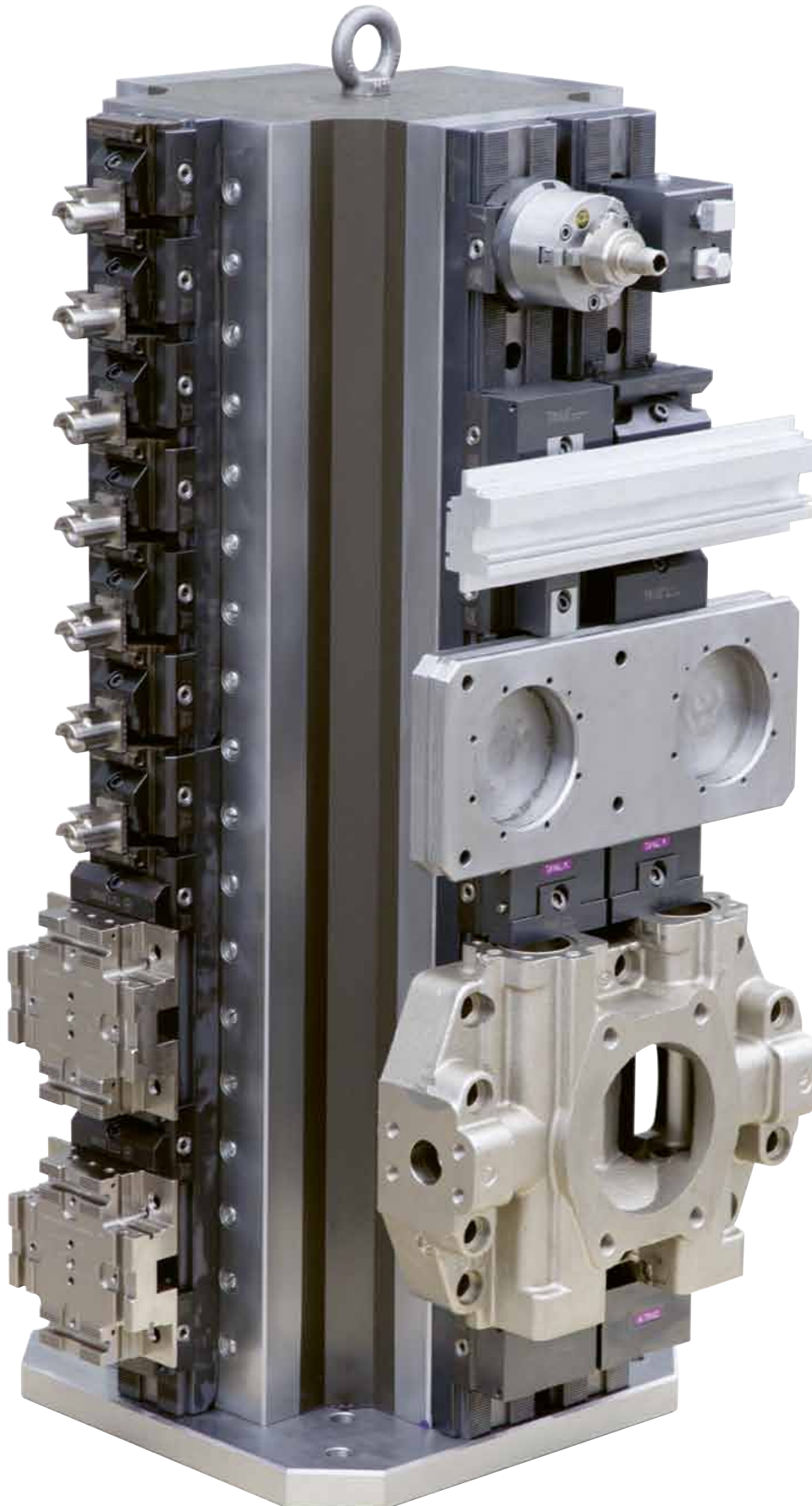

**25** tripoxyMINERAL Kreuzturm mit PowerCLAMP Schienen für chaotische Spannung  
tripoxyMINERAL Cross version with PowerCLAMP baserails for chaotic workholding



**31** tripoxyMINERAL mit unterschiedlichen Werkstücken bestückt  
tripoxyMINERAL tombstones holding a variety of workpieces

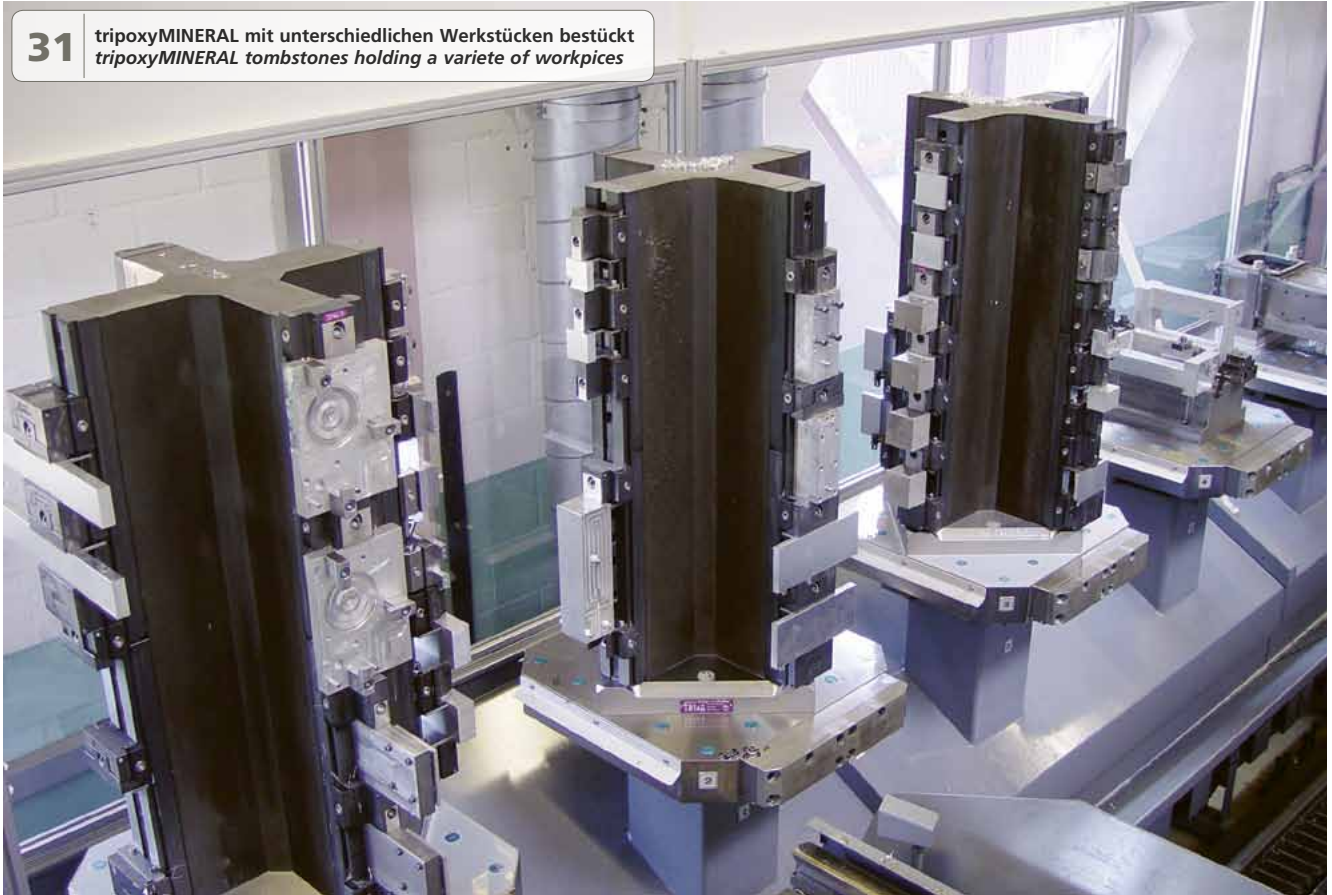

**32** Zentrischspanner auf einem Spezialturm  
Centric vices installed on a special tombstone

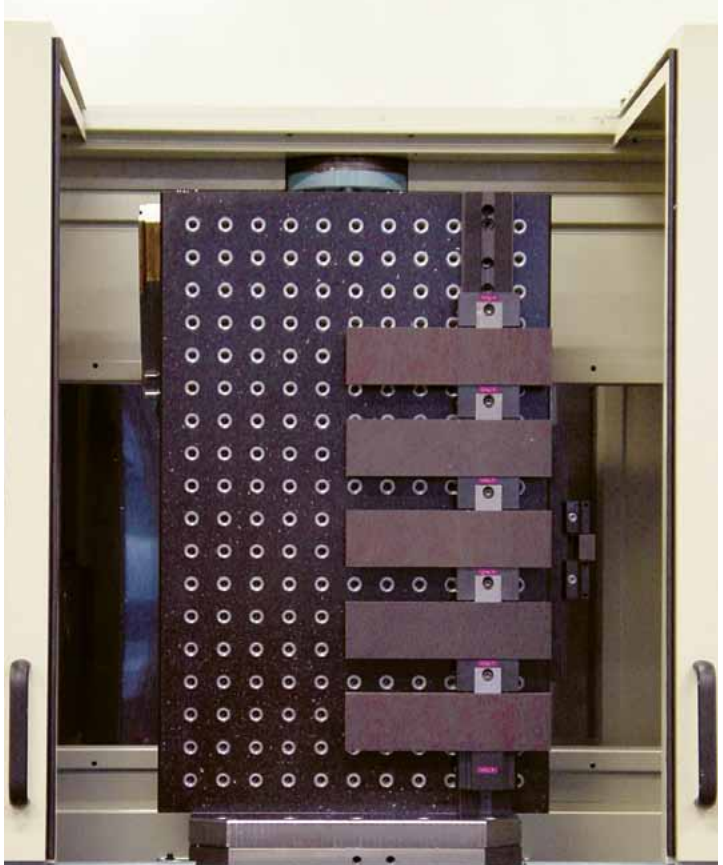

**33** Aufspannung mit Power Clamp auf einem Mineralgussturm  
Set up with Power Clamp on a tombstone made of composite concrete



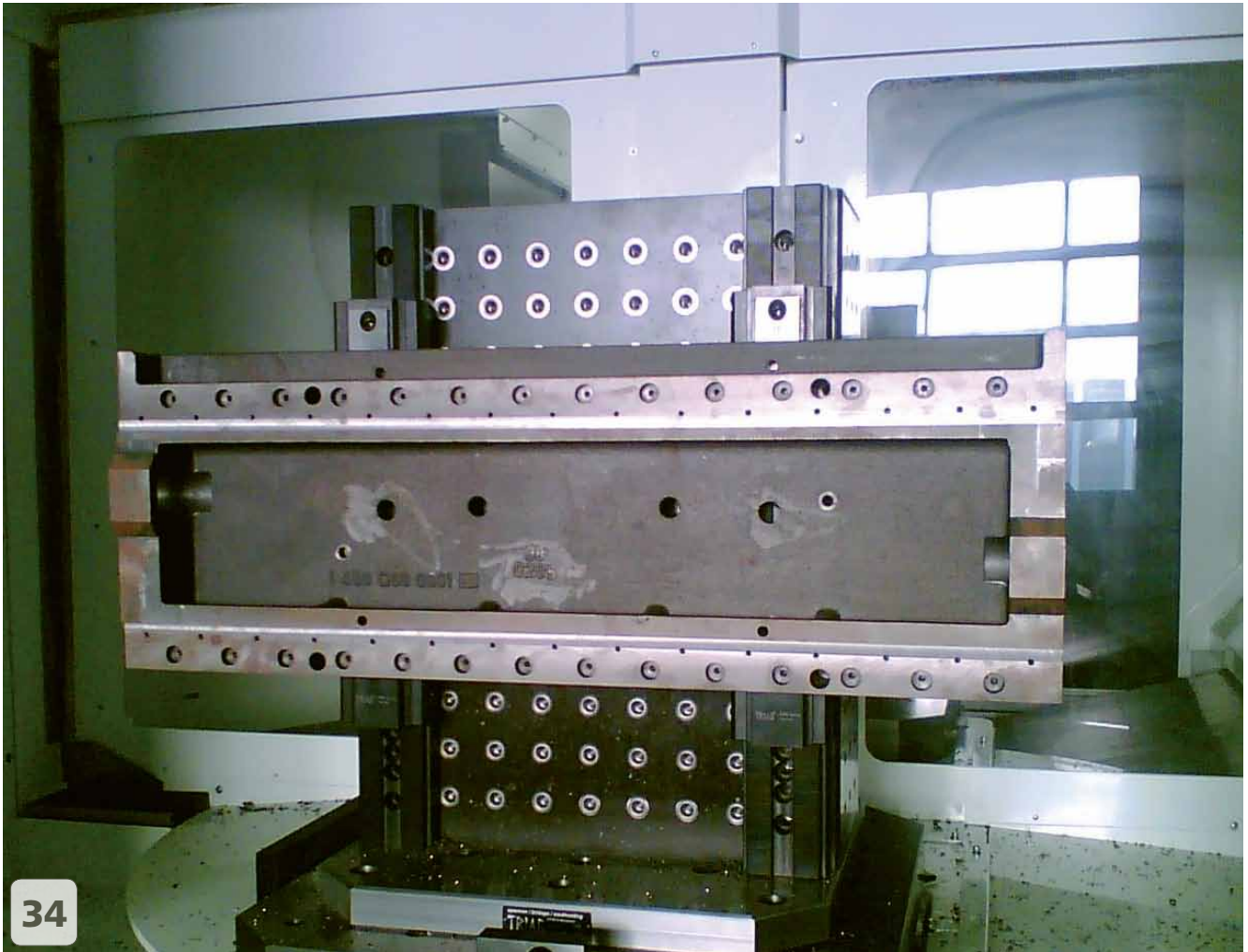

34

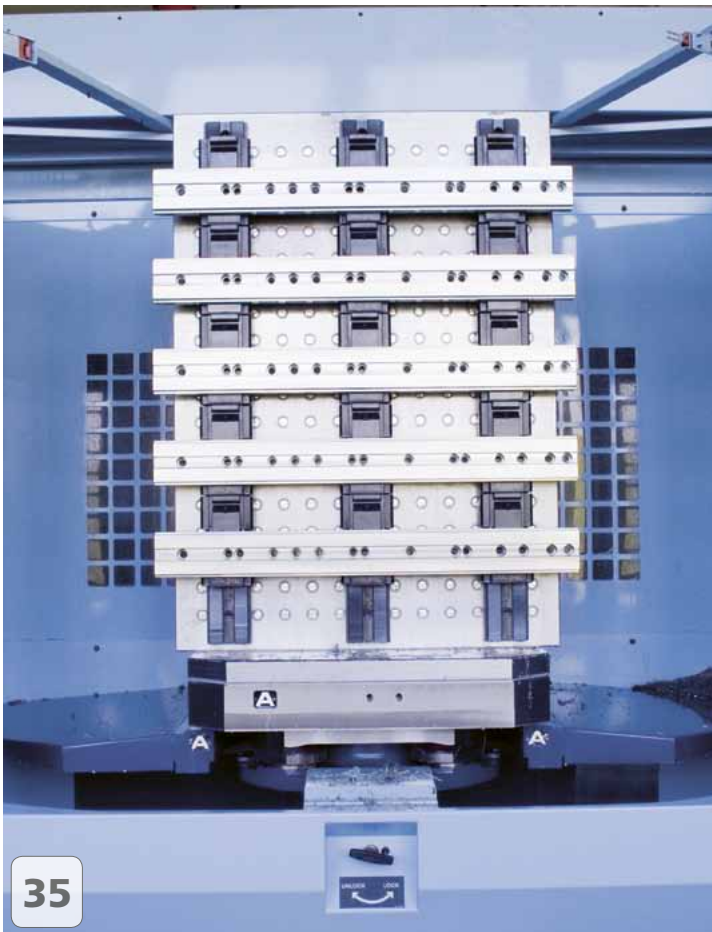

35

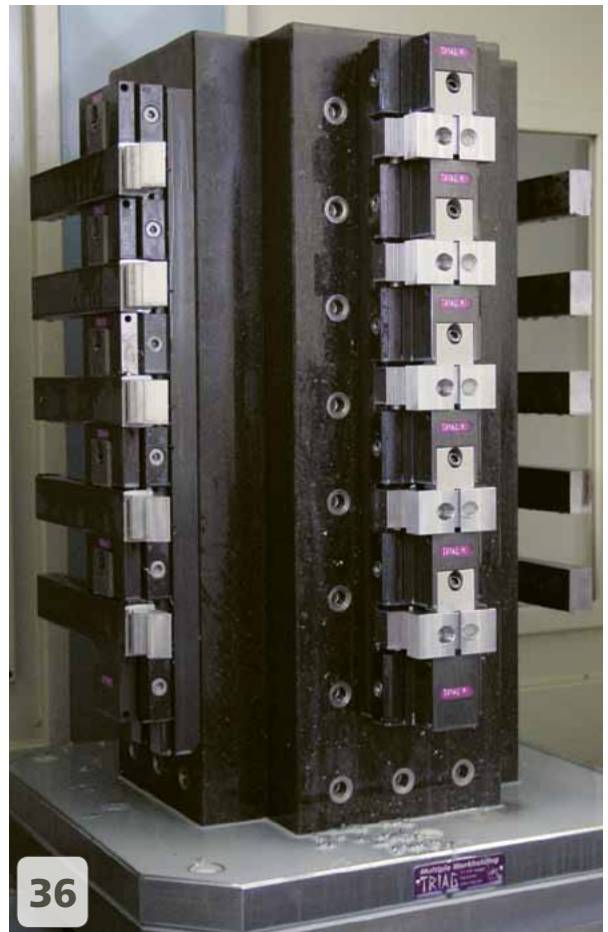

36



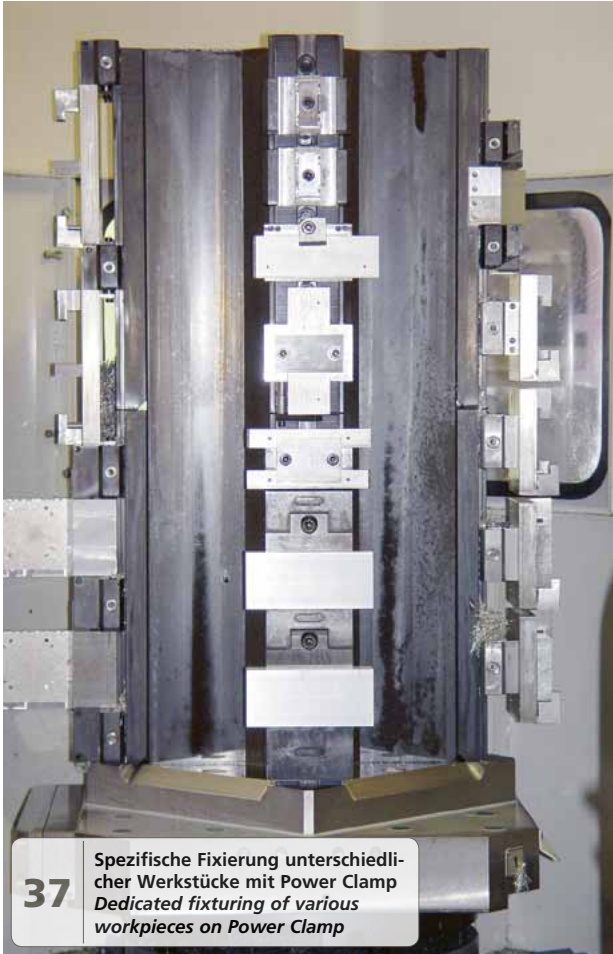

**37** Spezifische Fixierung unterschiedlicher Werkstücke mit Power Clamp  
*Dedicated fixturing of various workpieces on Power Clamp*



**38** Prägespannung auf sehr kleiner Einspannhöhe von 3 mm  
*Clamped 3 mm depth with direct stamping jaws*

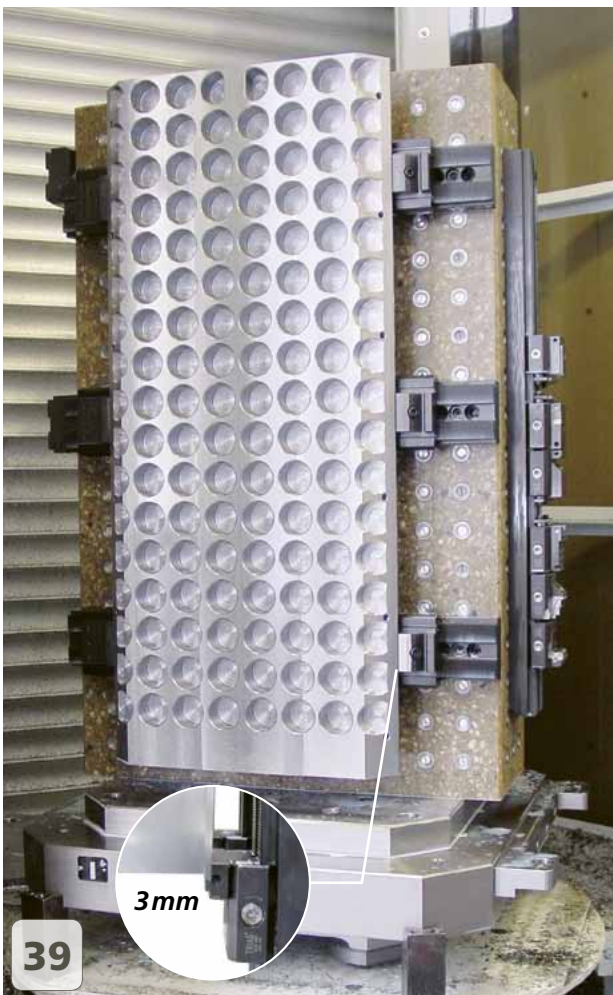

**39** 3mm



**40** Aufspannung mit Power Clamp auf einem „Tripoly“ Mineralgussturm  
*Set up with Power Clamp on a tombstone made of composite concrete*



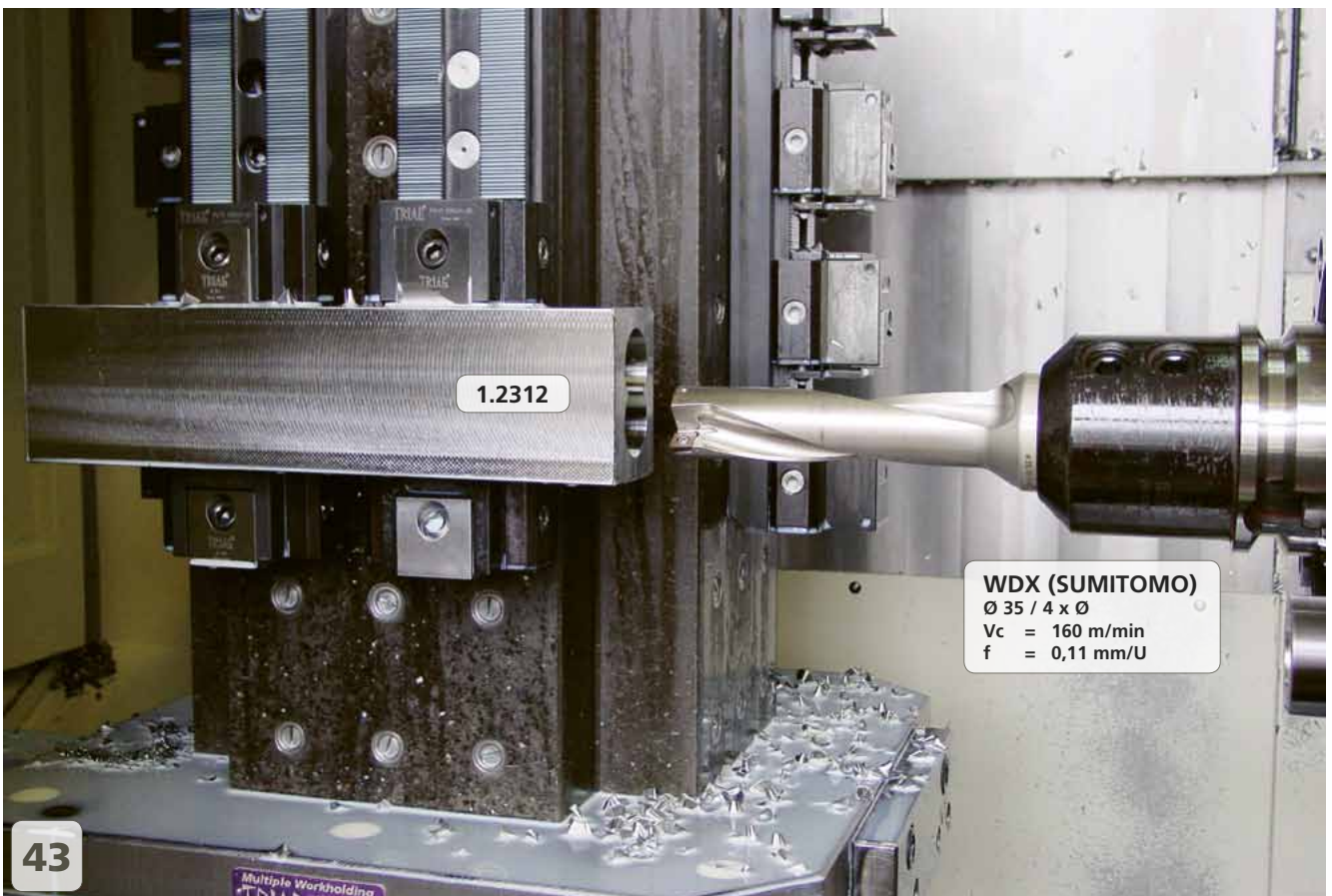
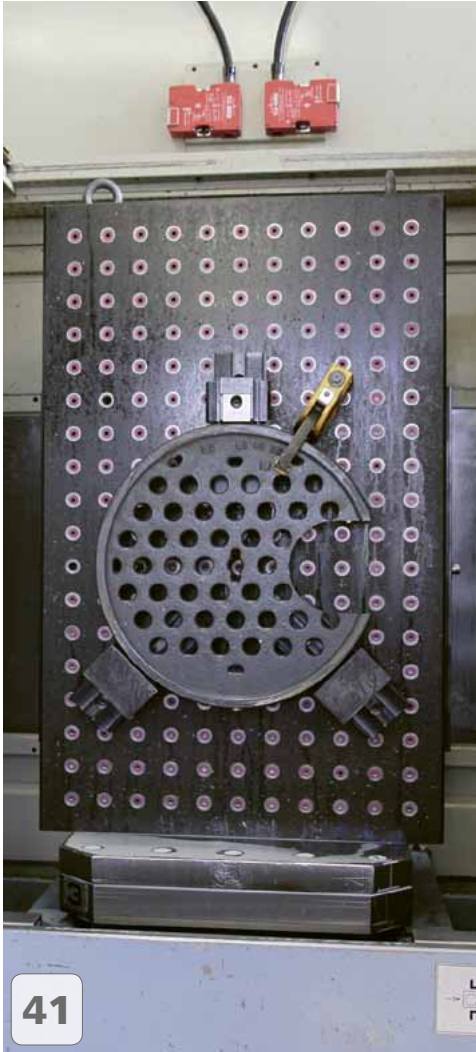





**200 x 400 x 1330**  
Flügelteil für Airbus A320  
Tail wing part for Airbus A320

**45** Stahlmineralguss-Säulen mit Power Clamp für die Fertigung von Flügelteilen.  
Steel epoxy frames machining wing parts on a Makino machine

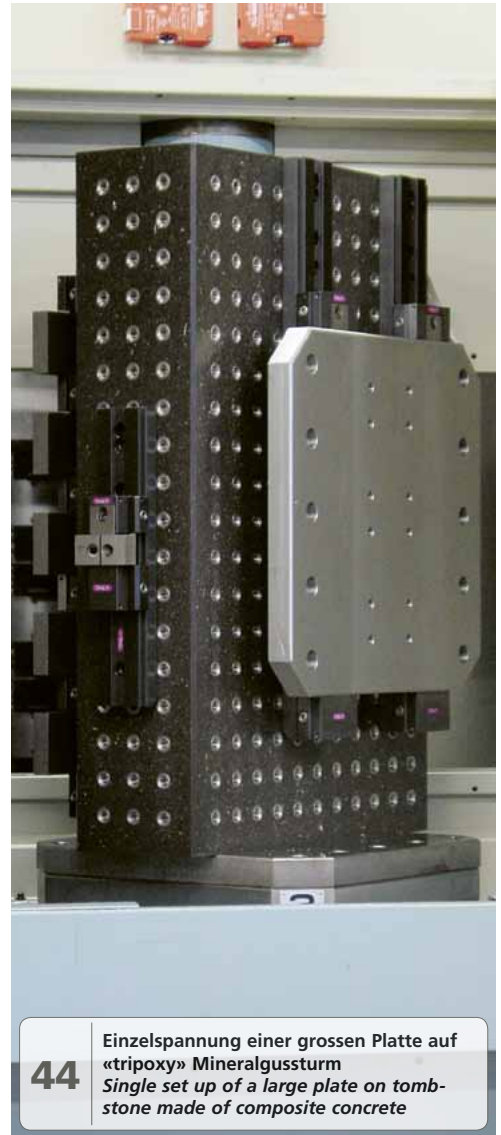

**44** Einzelspannung einer grossen Platte auf «tripoxy» Mineralgusssturm  
Single set up of a large plate on tomb-stone made of composite concrete



**46**



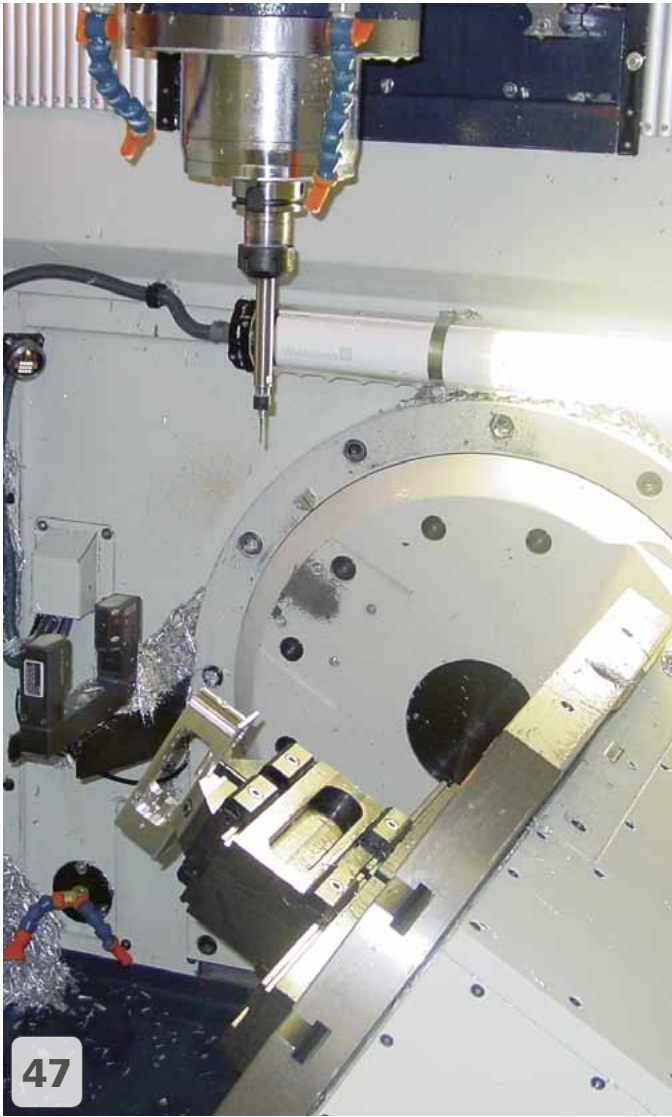

47



48 Im Einsatz auf der 5 Achsenmaschine  
In action on a 5 axis machine



49 ... im Einsatz auf der 5 Achsenmaschine  
... in action on a 5 axis machine



50



51 oppSystem in Anwendung mit Werkstückwechsler  
oppSystem in application with workpiece changer





52



54



53



55

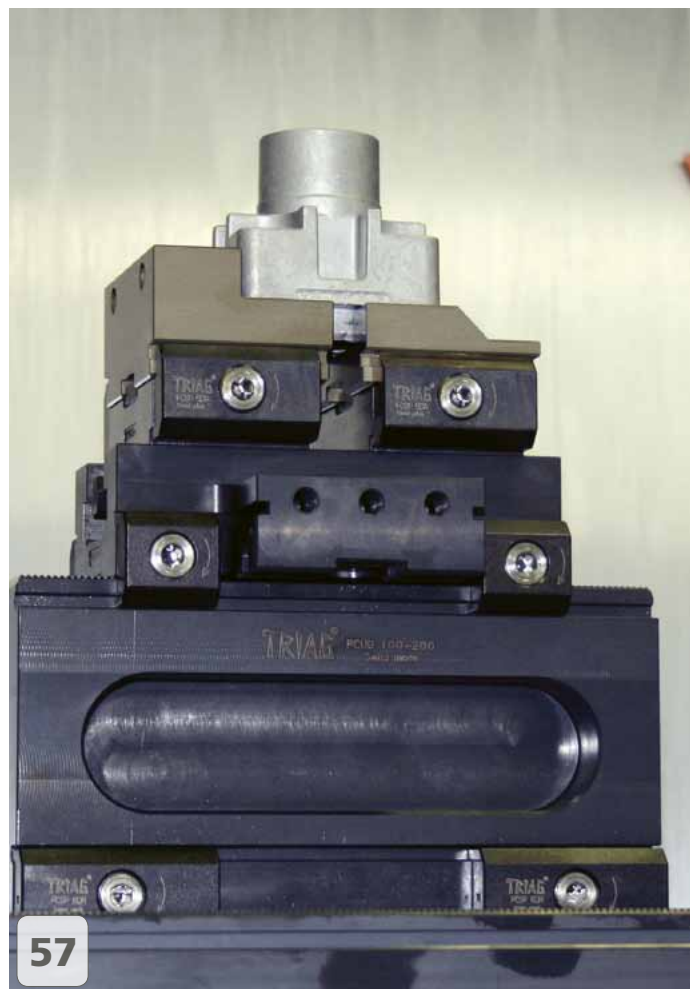

57



56



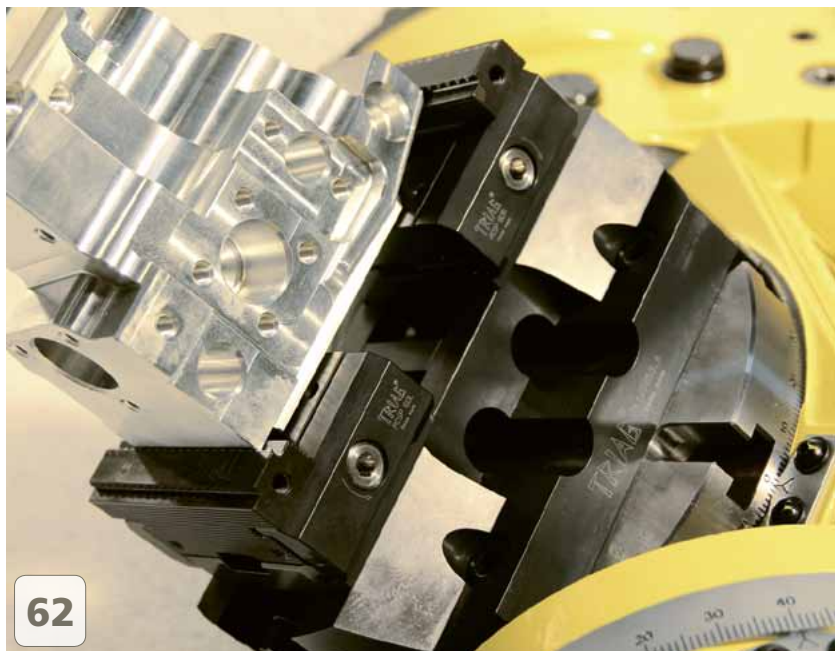
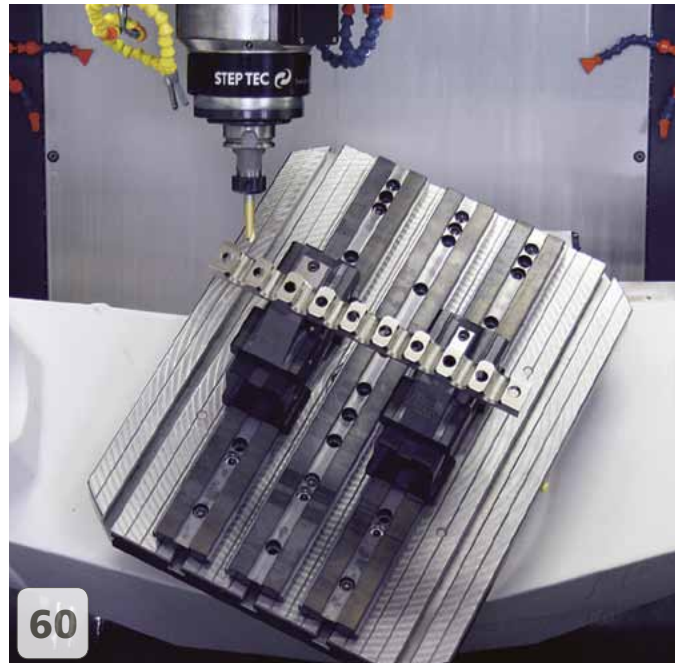

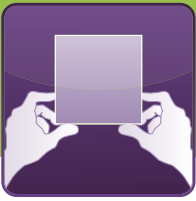

### Modulares Mehrfachspannen auf 5-Achsen-Maschinen

Immer öfter werden die 5-Achsen-Maschinen in den Produktionsabläufen eingesetzt, um den Ansprüchen der heutigen effizienten Herstellung gerecht zu werden und weltweit wettbewerbsfähig zu bleiben. Die Werkstückspannung ist sehr anspruchsvoll und fordert die technischen Mitarbeiter ausserordentlich, wie auf den nachfolgenden Bildern dargestellt.

### Modular workholding system for 5-axis machines

Increasingly, the 5-axis machines are used in the production processes to be in accordance with the demands of today's efficient manufacturing and remain globally competitive. The workpiece clamping is very demanding and calls for extremely technical staff, as shown on the following pictures.

#### Vorteile der Triag 5-Achsen Spannsysteme:

- Die unteren Basisschienen dienen sowohl als mechanisches Nullpunktspannsystem, aber auch als Spannstock.
- Die Spannkraft wirkt direkt beim Werkstück, trotzdem ist das Werkstück ob klein, lang oder gross mit kurzen Werkzeugen sehr gut zugänglich. (Die Einschränkung ist der Maschinentisch)!
- Bei der Dreiseitenbearbeitung ist auch Mehrfachspannung möglich.
- Es können über 200 verschiedene Spannmodule, sowie Rohmodule, Zentrischspanner, Dreibackenfutter, Spannzangenfutter, Vakuumspannmodule usw. aufgesetzt werden. Die Schnittstelle ist immer dieselbe.
- Sehr schnelles Umrüsten!
- Wenig Reinigungsaufwand, da keine T-Nuten vorhanden sind.
- Besonders gut geeignet für 5-Achsen-Maschinen. Alle Spannvorrichtungen können auch auf Horizontal- und Vertikalmaschinen universell eingesetzt werden.

#### Benefits of Triag 5-axis workholding systems:

- The lower base rails serve both as a mechanical zero-point clamping system, but also as a vice.
- The tension acts directly at the workpiece, the workpiece is still, whether small, long or large, very accessible with short tools. The constraint is the machine table!
- 3-side machining is possible as well.
- There may be placed over 200 different clamping modules, as well as raw modules, self-centring modules, three jaw chuck, collet chuck, vacuum clamping modules and so on. The interface is always the same.
- Very fast setup!
- Reduced cleaning required, since no T-slots available.
- Especially suitable for 5-axis machines. All clamping devices can also be used universally on horizontal and vertical machines.



Geeignet sowohl für kleine ...  
Especially suited for small ...



... als auch für grosse Werkstücke!  
... as well as large workpieces!



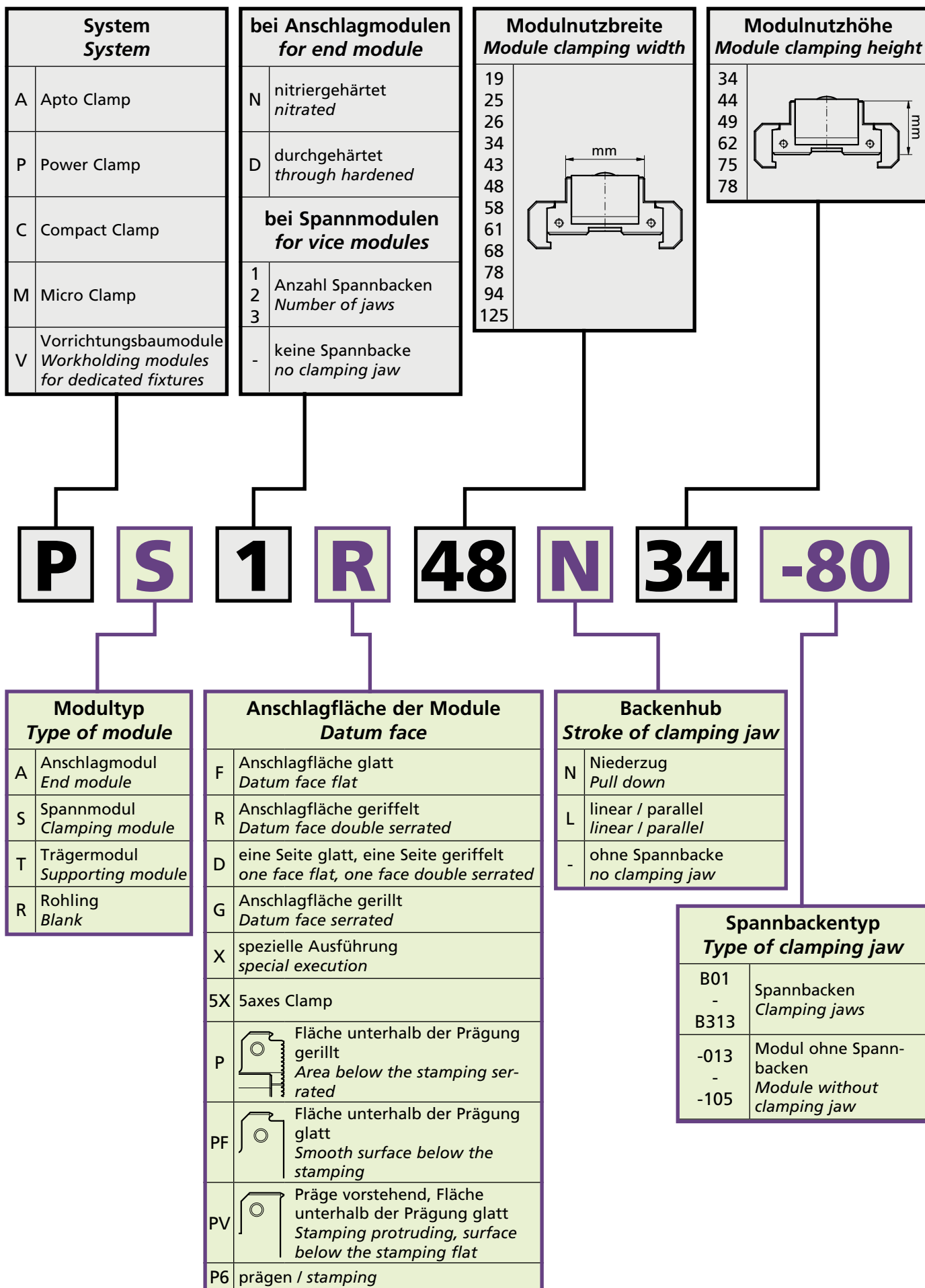

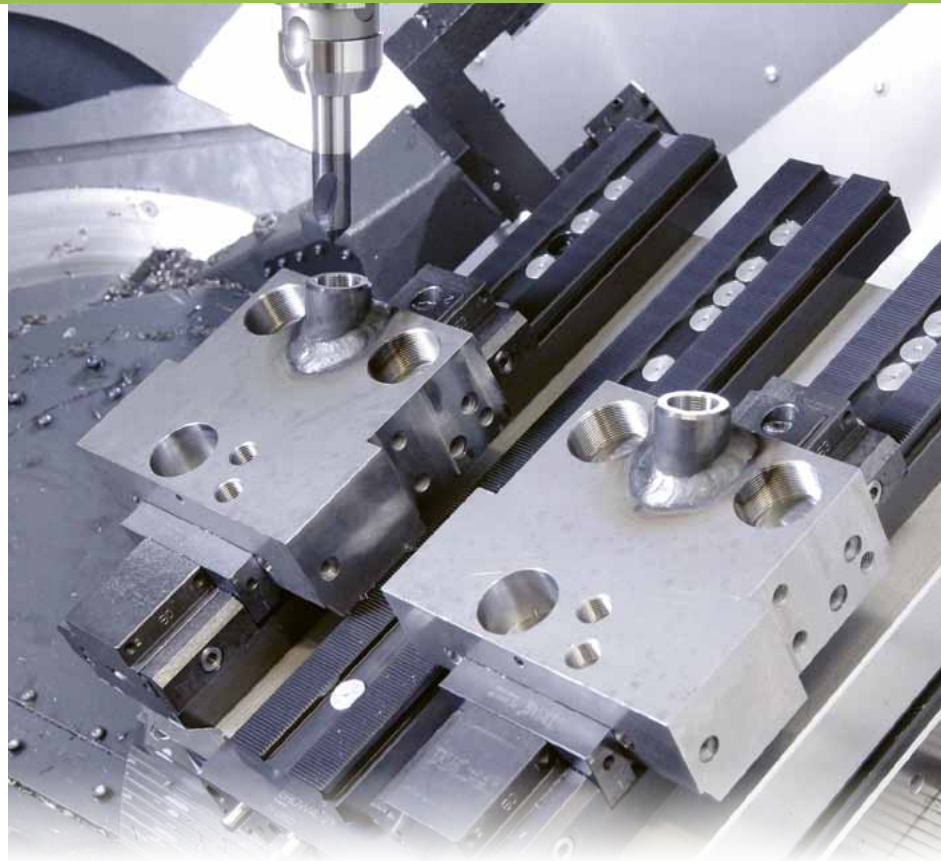

**Die Basisschiene ist die Grundlage des Power Clamp Spannsystems**

Der Einsatz der Basisschiene als Modularspannstock ist jedem Mechaniker ein Begriff. Die Vorteile ihres Einsatzes als mechanisches Nullpunktsystem sind in der Zwischenzeit ebenfalls ins Planungsdenken der mechanischen Fertigung eingeflossen.

Die Power Clamp-Schiene dient als Basis für über 200 verschiedene Spannmodule, Zentrischspanner, Rohlingsmodule und Vakuumplatten.

**The serrated base rail is the basic structure of the Power Clamp workholding system**

Using the base rail as a modular workholding vise is standard practice to any mechanic. The advantages of using it as a zero point system have also widely influenced the planning stages of mechanical production.

The Power Clamp base rail serves as a supporting plate for more than 200 different clamping modules, self centring vises, blank modules and vacuum clamping plates.

Toleranz gilt für alle PCB-Basisschienen / Tolerance applies to all PCB base rails

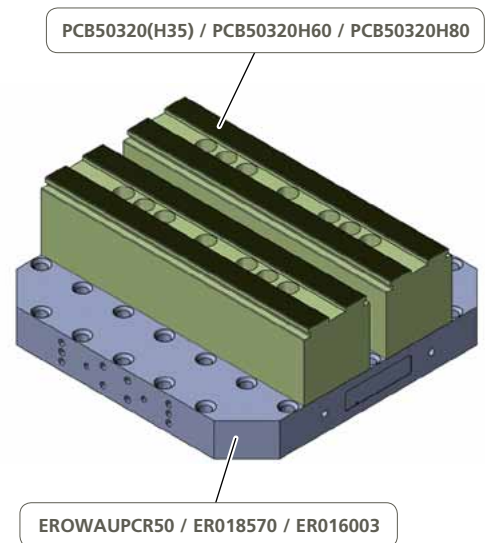
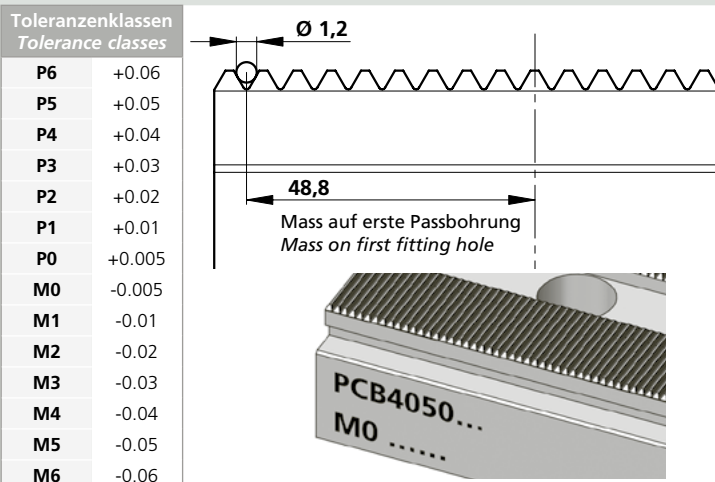

Separat bestellen / Separate order

Bestellbeispiel / Ordering example: 2x PCB50320H80 & 1x ER018570





PCB6090 kg ~1,8

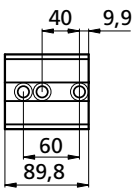

PCB25300 kg ~5,4

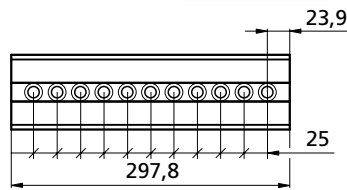

PCB4050500 kg ~9,9

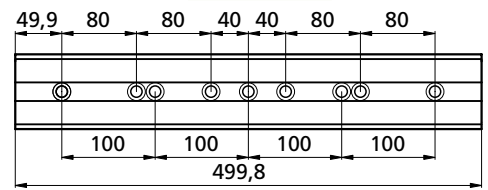

PCB4050125 kg ~2,3

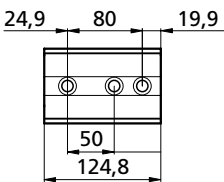

PCB25200 kg ~3,6

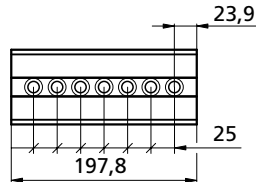

PCB4050550 kg ~10,8

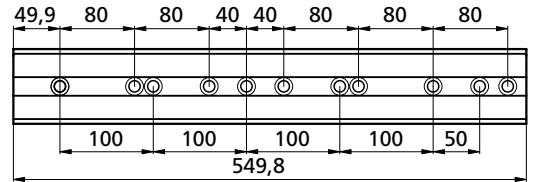

PCB4050220W2 kg ~4,3

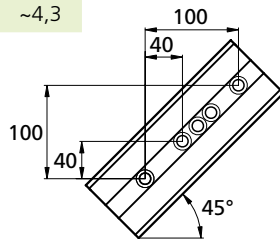
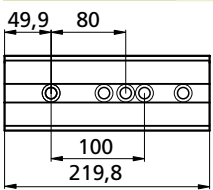

PCB4050600 kg ~11,8

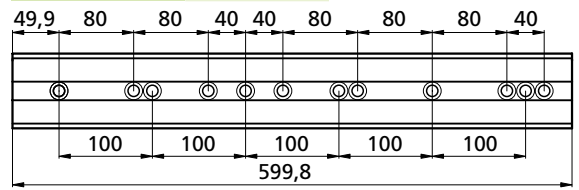

PCB2550250 kg ~4,8

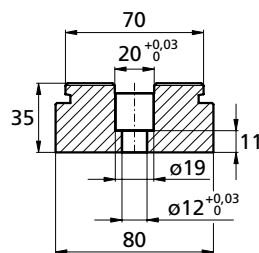
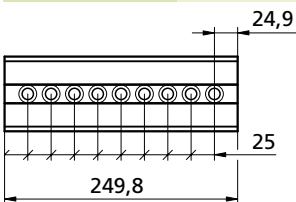

PCB4050650 kg ~12,8

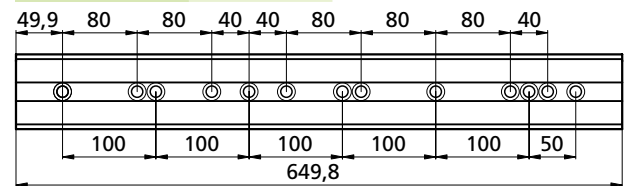

PCB50320 kg ~6,0

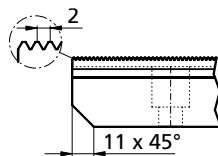
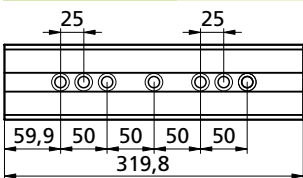

PCB4050700 kg ~13,8

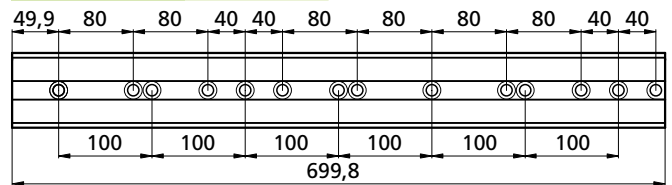

PCB4050350 kg ~6,9

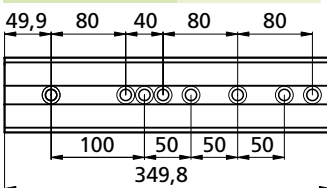

PCB4050750 kg ~14,8

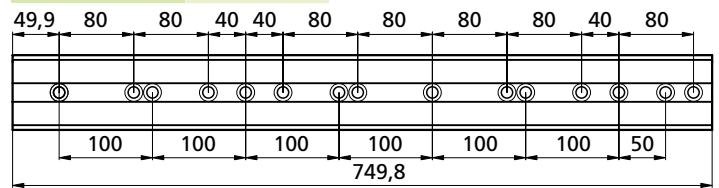

PCB4050400 kg ~7,9

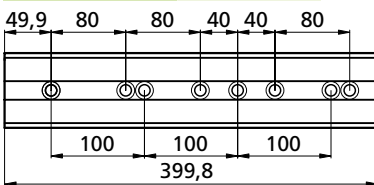

PCB4050800 kg ~15,3

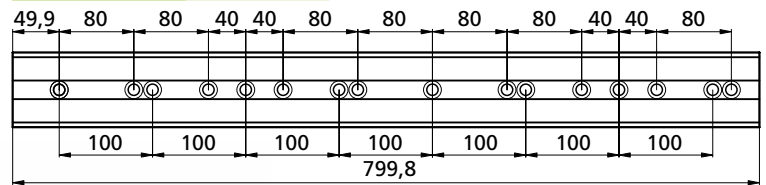

PCB4050450 kg ~8,9

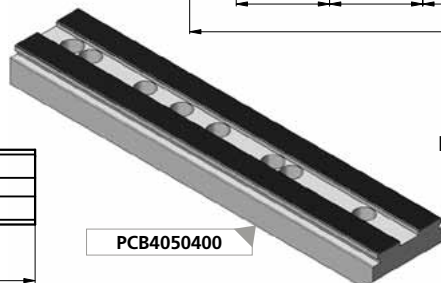
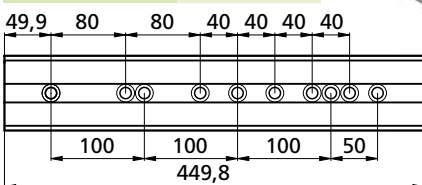

PCB4050400

Basisschienen in Zoll  
Base rails in inch

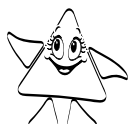

Bestellbeispiel / Ordering example: PCB4050125

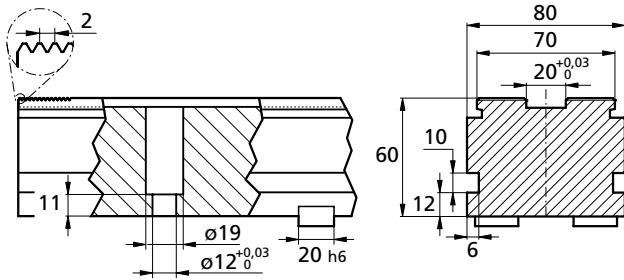

**PCBR40** Befestigungsart / Mounting type

**1. Befestigung 1. Fastening**  
Mit den seitlichen Pratten, kann die Basisschiene frei auf Ihrem Maschinentisch montiert werden.  
*With the lateral clamps, the base-rail can be mounted freely on your machine table.*

**2. Befestigung 2. Fastening**  
Diese Nutensteine sind zum Ausrichten der Basisschiene auf Ihrem Maschinentisch.  
*These t-slot nuts are for aligning the base-rail on your machine table.*

<b>PCB50320H60</b>
1x TF190449
2x M6X12ISO4762
2x SM1136-20
kg ~10,5

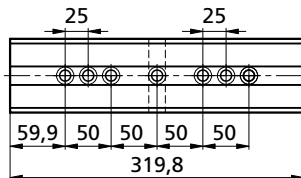

<b>PCB100350H60</b>
1x TH170888
2x M6X12ISO4762
2x SM1136-20
kg ~12,0

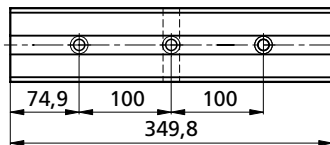

<b>PCB100400H60</b>
1x TB140546
2x M6X12ISO4762
2x SM1136-20
kg ~13,6

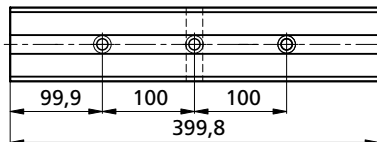

<b>PCB100500H60</b>
1x TB140553
2x M6X12ISO4762
2x SM1136-20
kg ~17,0

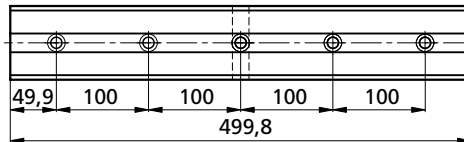

<b>PCB100600H60</b>
1x TB140556
2x M6X12ISO4762
2x SM1136-20
kg ~20,5

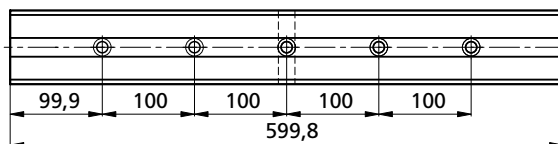

<b>PCB100650H60</b>
1x TB140559
2x M6X12ISO4762
2x SM1136-20
kg ~22,0

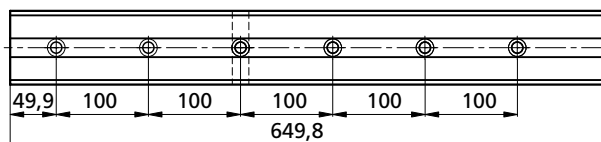

<b>PCB100690H60</b>
1x ZL100122
2x M6X12ISO4762
2x SM1136-20
kg ~22,6

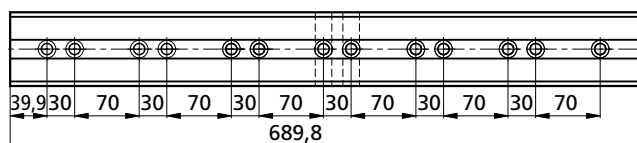

<b>PCB100850H60</b>
1x TB140562
2x M6X12ISO4762
2x SM1136-20
kg ~28,2

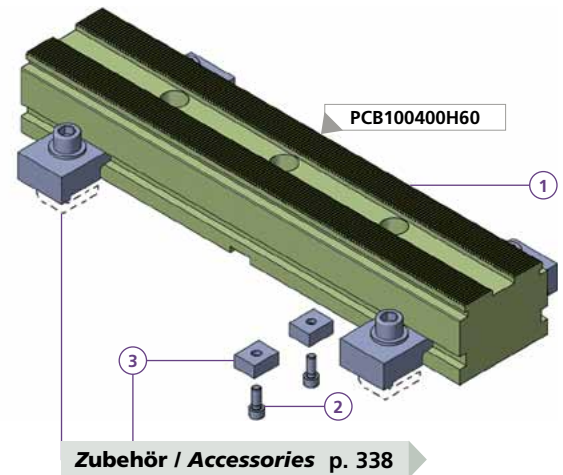
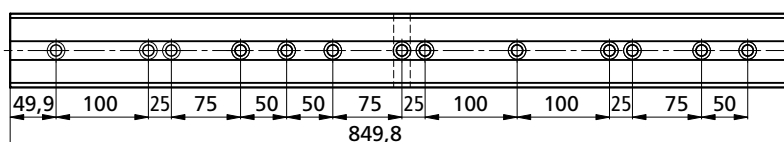

Zubehör / Accessories p. 338

**PCBR40**

4	1x M12X45ISO4762
5	1x TN100251
6	1x TK200035
kg	~0,25

**T-Nutensteine T-slot nuts**  
T-Nutensteine je nach Maschinentisch, muss separat bestellt werden.  
*T-slot nuts depending on the machine table, must be ordered separately.*

Bestellbeispiel / Ordering example: 1x PCB100400H60 & 2x M6X12ISO4762 & 2x SM1136-20





**PCB4050125H80** kg ~7,5

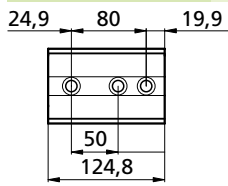

**PCB50320H80** kg ~14,4

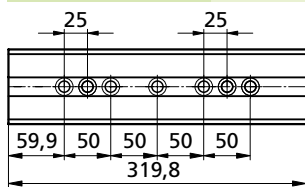

**PCB50350H80** kg ~15,8

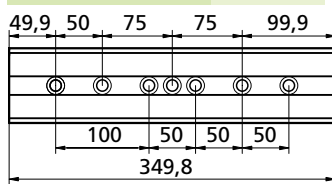

**PCB50400H80** kg ~18,2

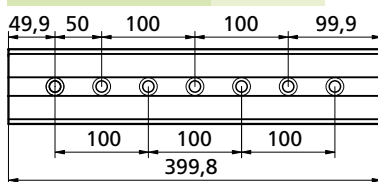

**PCB50450H80** kg ~20,3

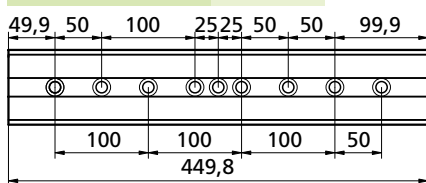

**PCB50500H80** kg ~22,8

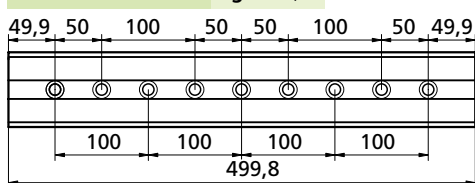

**PCB50550H80** kg ~24,8

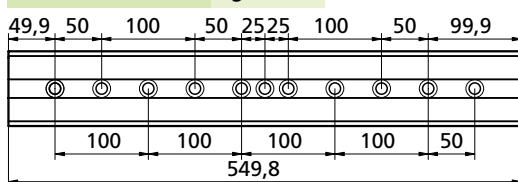

**PCB50600H80** kg ~27,3

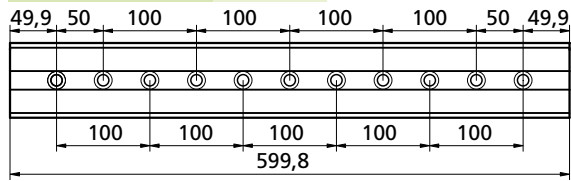

**PCB50650H80** kg ~29,4

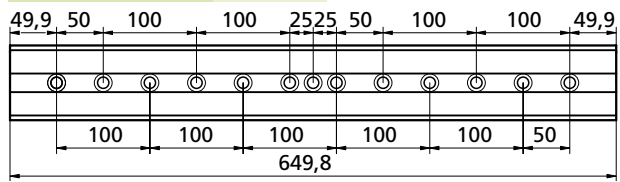

**PCB50700H80** kg ~31,8

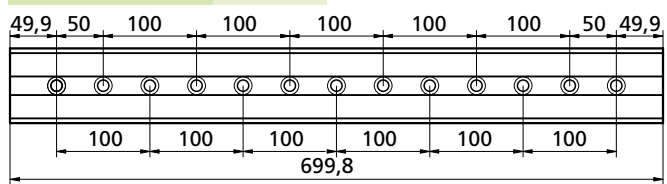

**PCB50750H80** kg ~33,9

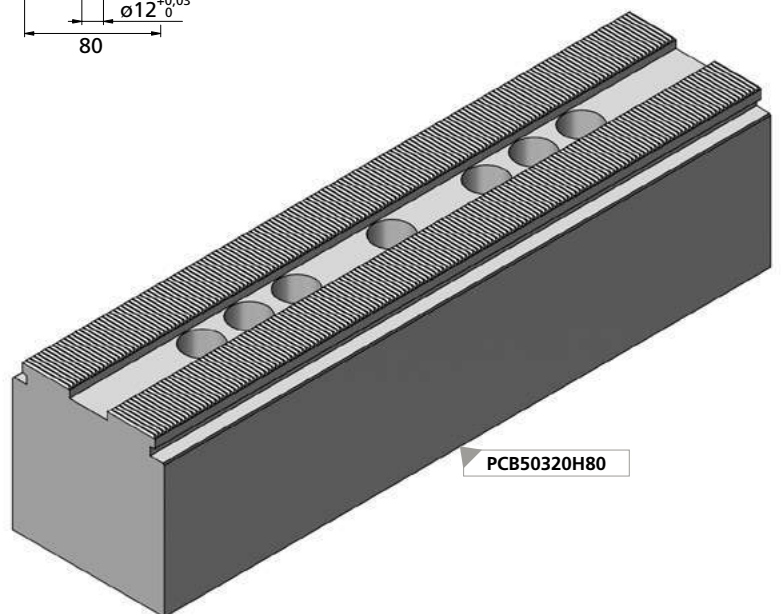
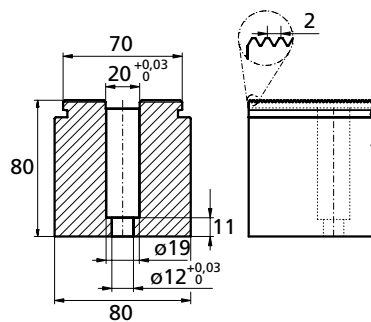
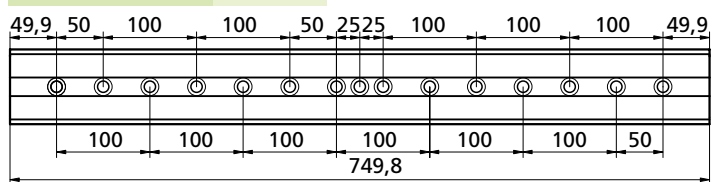

PCB50320H80



PCMB50600H175 kg ~39

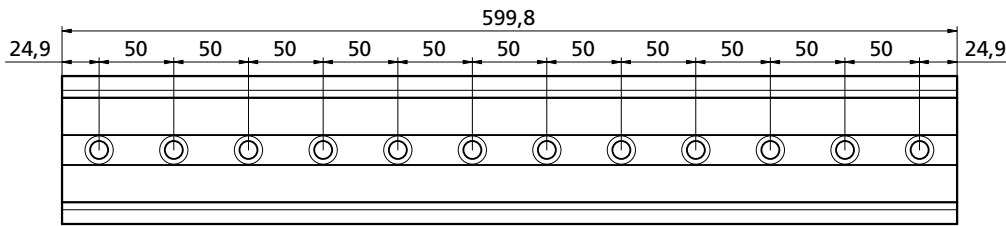

PCMB50500H175 kg ~34

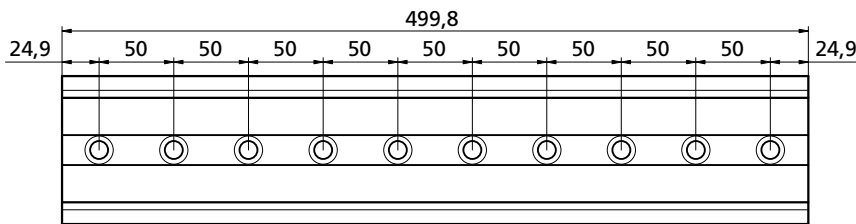

PCMB50400H175 kg ~27

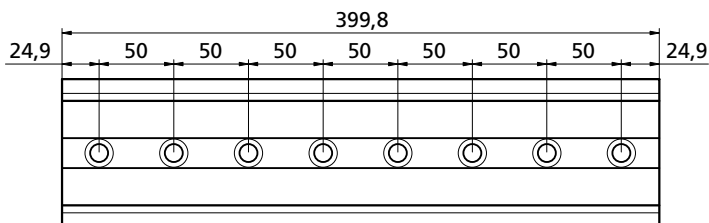

PCMB50300H175 kg ~22

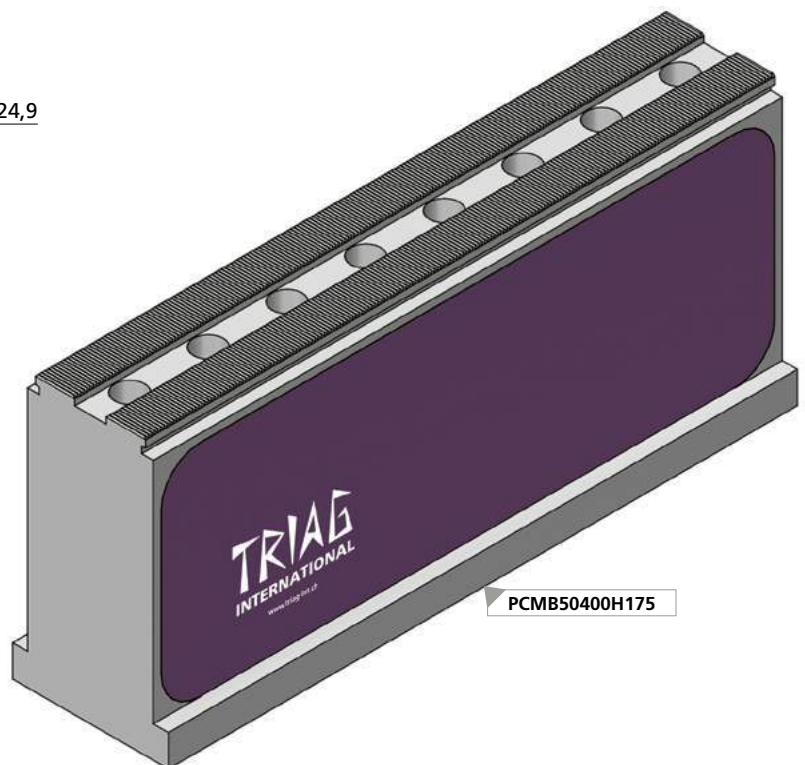
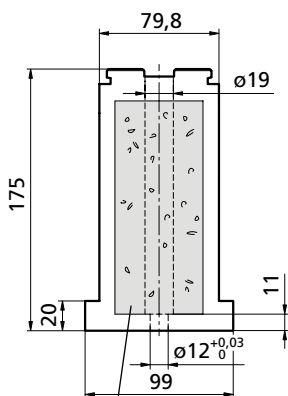
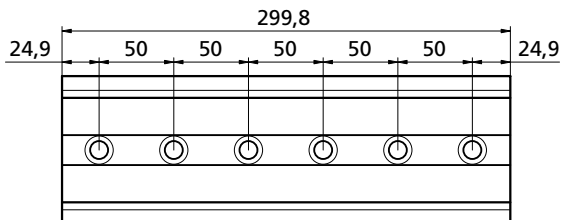

**Epoxy Mineral**  
 Für gute Vibrationsdämpfung  
 For brilliant dampening effect



# Kupplungsstück (Basisschienen zum koppeln) Coupling element (Basic rails to coupling)



powerCLAMP

## Kupplungsstücke für PCB Basisschiene auf Mineralgus-Türmen

Mit diesen Kupplungsstücken ist es möglich, die PCB Basisschienen zu verlängern. Aufgrund des durchgängigen Kraftschlusses wird eine übermäßige Belastung des Mineralgussturmes vermieden. Erforderlich ist eine Modifikation der Enden der Basisschienen gemäss der untenstehenden Zeichnung durch den Anwender. Selbstverständlich können neue Schienen bereits mit dieser Modifikation ausgeliefert werden.

So können die zwei Kupplungsstücke montiert werden, die nach dem Platzieren der Schienen eingesetzt und festgezogen werden. Eine zusätzliche Schraube (B) nimmt allfällige, senkrecht zur Befestigungsfläche auftretende Kräfte auf.

## Coupling element for PCB base rails mounted on epoxy mineral tombstones

With this coupling element, it is possible to extend the PCB base rail by a second rail. Due to the frictional connection, the behaviour of the associated items is approximate to the behaviour of a continuous rail. A modification according to the drawing below (made by the customer) is required at the end of the base rails. New base rails can be supplied with this modification.

So the two coupling elements can be placed between the base rails. An additional screw (B) is taken the force flatwise to the seating.



Montageanleitung siehe Video  
Assembly instructions see video

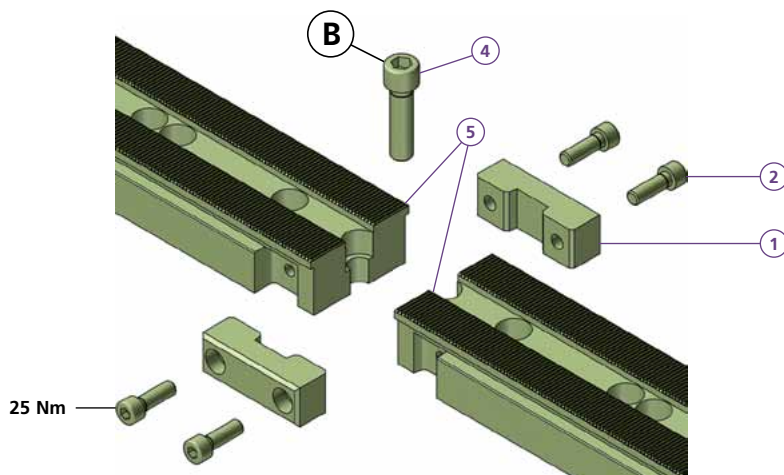

25 Nm

PCBP69SET	5 PCB4050250KP	5 PCB4050400KP	5 PCB4050450KP	5 PCB4050500KP	5 PCB4050650KP	5 PCB4050700KP
1 2x TW090078	L1 = 250	L1 = 400	L1 = 450	L1 = 500	L1 = 650	L1 = 700
2 4x M8X25ISO4762	kg ~5,1	kg ~7,9	kg ~8,9	kg ~9,9	kg ~12,8	kg ~13,8
4 1x M12X45ISO4762						
kg ~0,4						

Bestellbeispiel / Ordering example: PCB4050250KP

PCB850SET	PCB900SET	PCB950SET	PCB1000SET
1 1x PCB4050400KP	1 1x PCB4050650KP	1 1x PCB4050700KP	1 2x PCB4050500KP
2 1x PCB4050450KP	2 1x PCB4050250KP	2 1x PCB4050250KP	3 1x PCBP69SET
3 1x PCBP69SET	3 1x PCBP69SET	3 1x PCBP69SET	4 4x TWPAS1240
4 4x TWPAS1240	4 4x TWPAS1240	4 4x TWPAS1240	5 6x M12X40ISO4762
5 5x M12X40ISO4762	5 6x M12X40ISO4762	5 7x M12X40ISO4762	6 10x PCPF16L6
6 9x PCPF16L6	6 10x PCPF16L6	6 11x PCPF16L6	7 8x PCPF16L18
7 9x PCPF16L18	7 12x PCPF16L18	7 12x PCPF16L18	kg ~20,9
kg ~17,8	kg ~18,7	kg ~19,8	

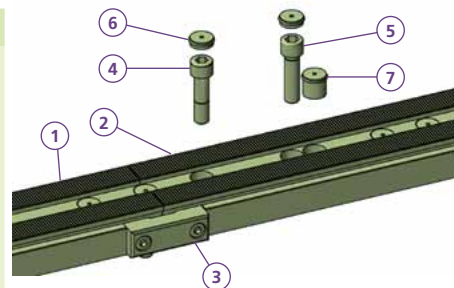

Detailzeichnung zum Bearbeiten aller **Basisschienen H35**, um die Aussparungen für das Kupplungsstück bei vorhandenen Schienen nachträglich herzustellen.

Detail drawing for machining all **base rails H35** to retrofit the recesses for the coupling piece on existing rails.

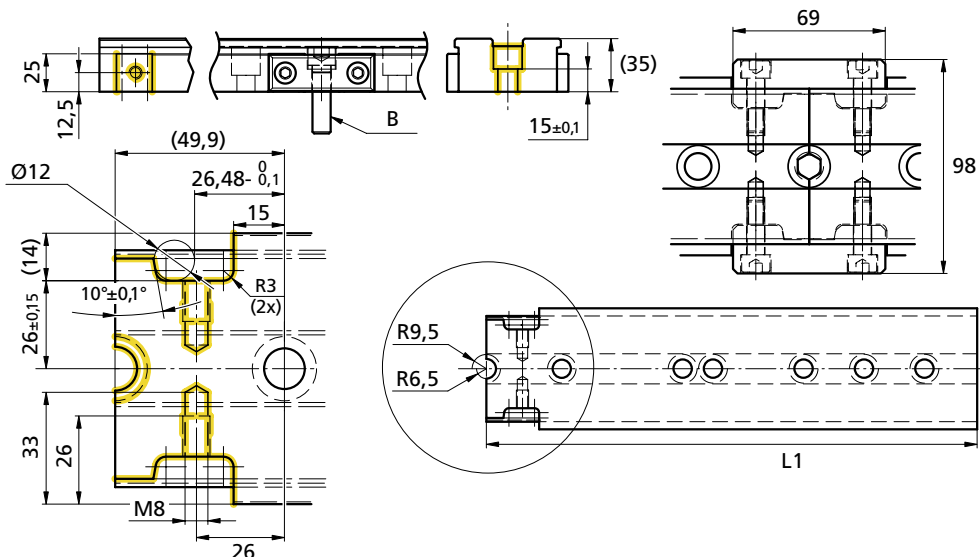

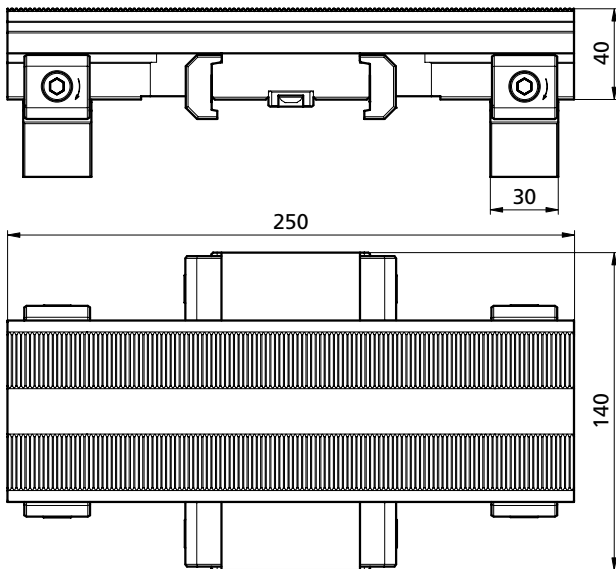
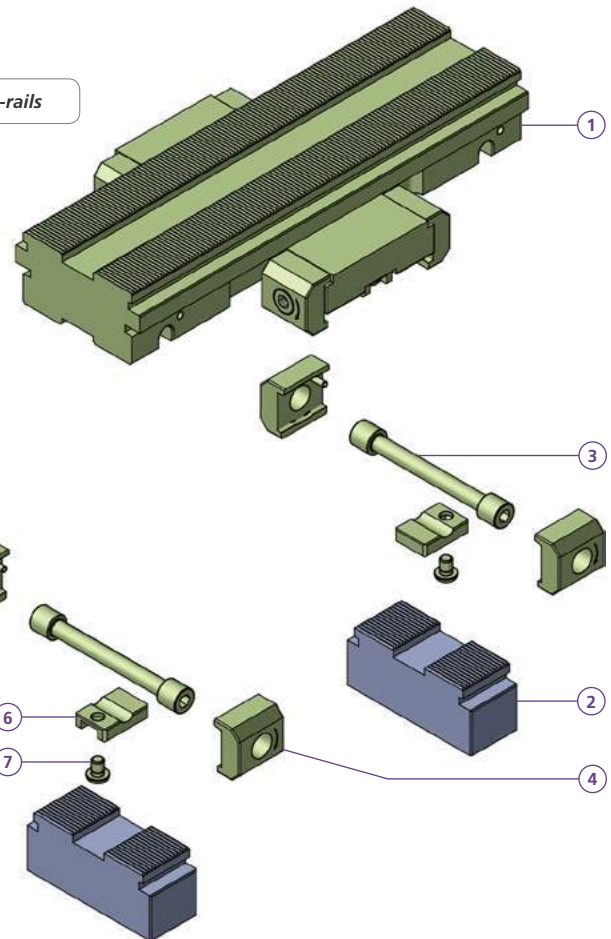
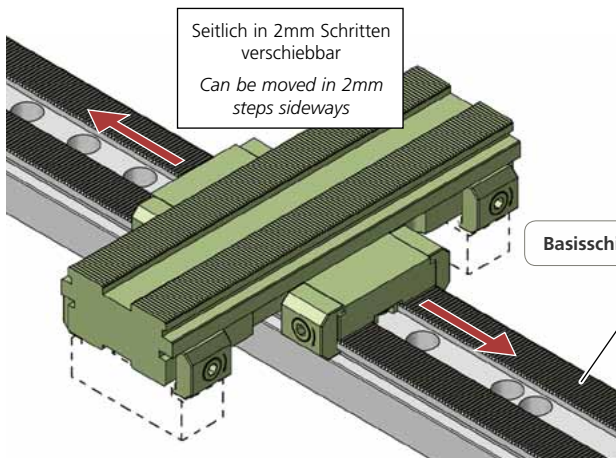

PCB250Q90H35	
①	1x TH151032
②	2x —
③	4x PCS14
④	4x PCSP30L
⑤	4x PCSP30R
⑥	4x PCGU2030
⑦	1x M6X8ISO7380
kg	~8,18

Schienenhöhe / Rail height

AS35 (H = 35)	AS60 (H = 60)	AS80 (H = 80)

Seitliche Stützen

Bei Gebrauch der Querschiene 90°, werden je nach Höhe der Basisschiene auf dessen sie aufgesetzt sind, zwei seitliche Stützen AS35 / AS60 / AS80 unterlegt.

Side support

When using the cross rail 90°, a side support AS35 / AS60 / AS80 is underlaid, depending on the height of the base rail on which it is placed.

Bestellbeispiel / Ordering example: PCB250Q90H35



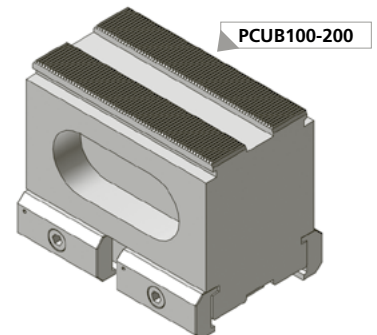
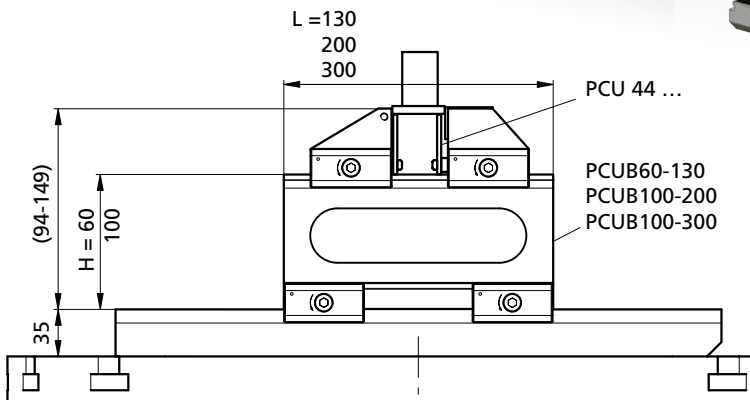
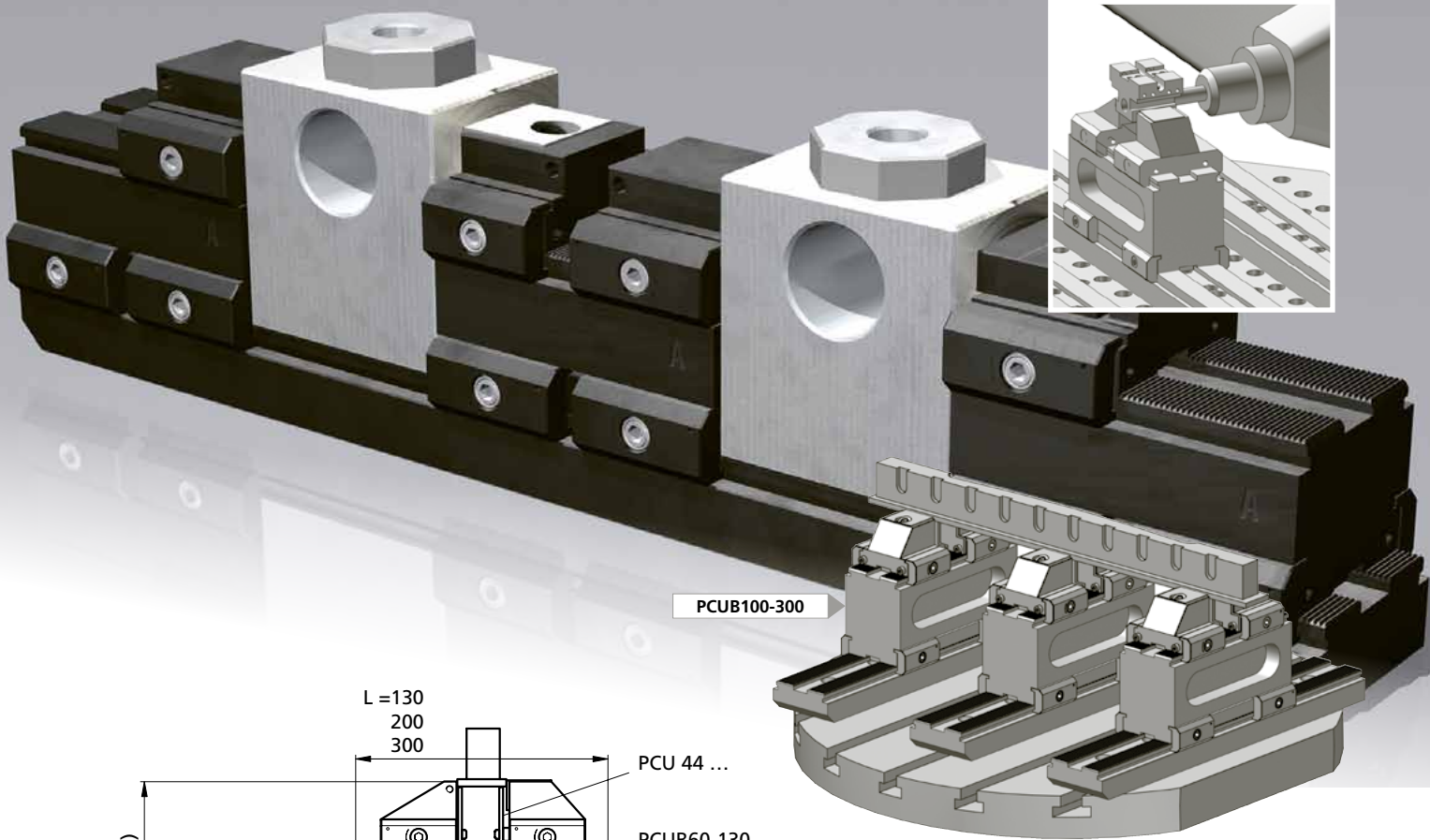

- | PCUB60-130  |                |
|-------------|----------------|
| ①           | 1x TK120596    |
| ③           | 2x PCSP60R     |
| ④           | 2x PCSP60L     |
| ⑤           | 2x PCS14       |
| ⑥           | 2x PCGU2049    |
| ⑦           | 2x M6X8I5O7380 |
| L           | = 130          |
| H           | = 60           |
| kg          | ~5,8           |
| PCUB100-200 |                |
| ①           | 1x TK130108    |
| L           | = 200          |
| H           | = 100          |
| kg          | ~10,5          |
| PCUB100-300 |                |
| ①           | 1x TK130109    |
| ③           | 3x PCSP60R     |
| ④           | 3x PCSP60L     |
| ⑤           | 3x PCS14       |
| ⑥           | 3x PCGU2049    |
| ⑦           | 3x M6X8I5O7380 |
| L           | = 300          |
| H           | = 100          |
| kg          | ~16            |

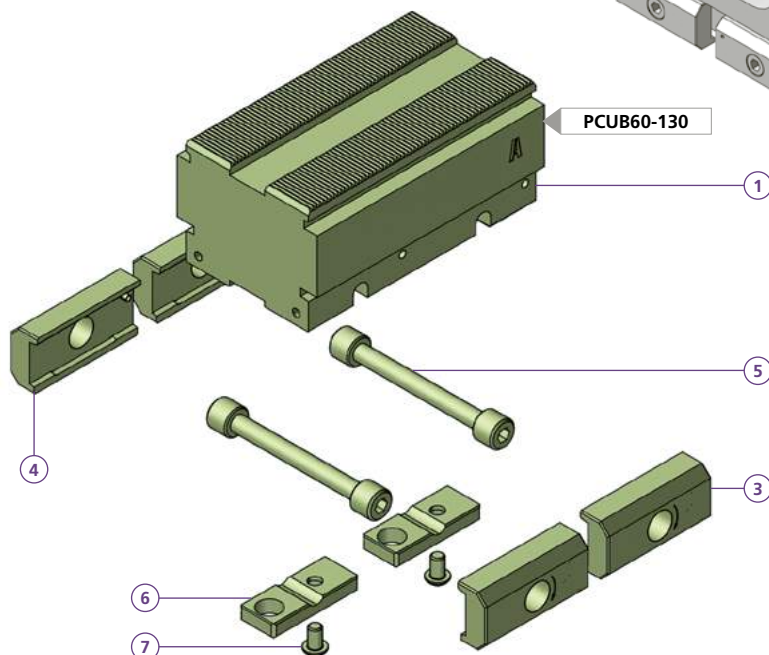







**PCUB115-200-R25**

**PCUB115-300-R25**

**powerCLAMP**

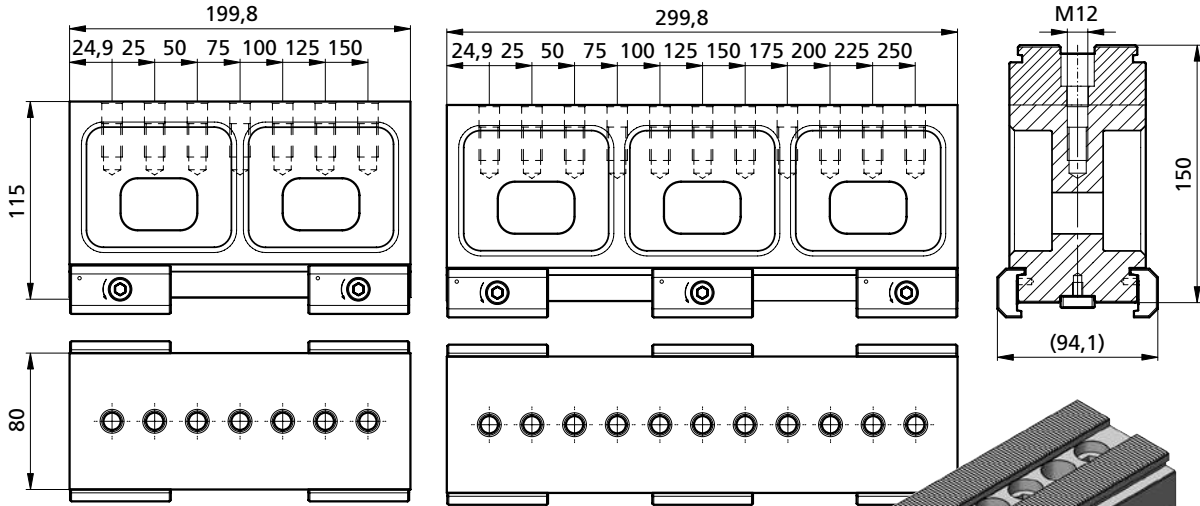

**PCB25200** kg ~3,6

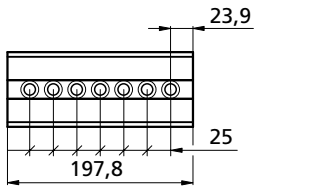

**PCB25300** kg ~5,4

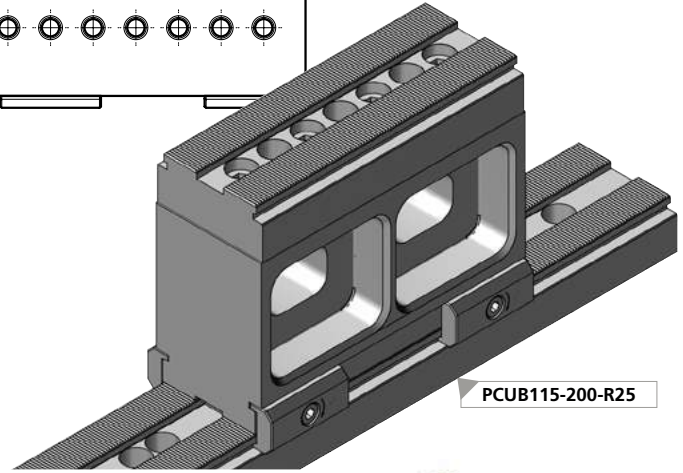
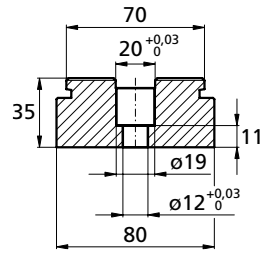
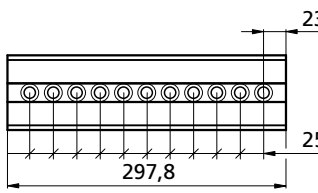

**PCUB115-200-R25**

**PCUB115-200-R25**

- ① 1x TK130323
  - ② 1x PCB25200
  - ③ 2x PCSP60R
  - ④ 2x PCSP60L
  - ⑤ 2x PCS14
  - ⑥ 2x PCGU2049
  - ⑦ 2x M6X8ISO7380
  - ⑨ 2x TWPAS1240
  - ⑩ 2x M12X40ISO4762
- kg ~13

**PCUB115-300-R25**

- ① 1x TK130324
  - ② 1x PCB25300
  - ③ 3x PCSP60R
  - ④ 3x PCSP60L
  - ⑤ 3x PCS14
  - ⑥ 3x PCGU2049
  - ⑦ 3x M6X8ISO7380
  - ⑨ 2x TWPAS1240
  - ⑩ 4x M12X40ISO4762
- kg ~19,6

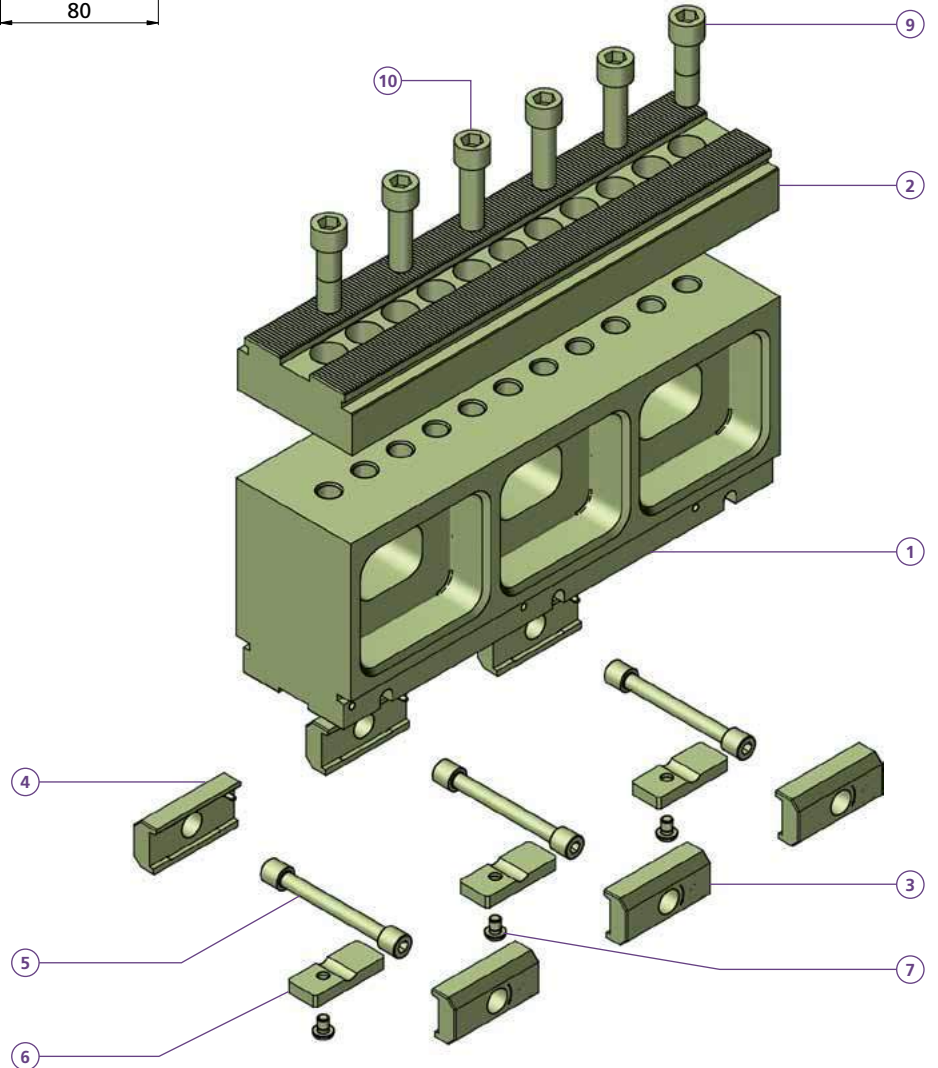

Bestellbeispiel / Ordering example: **PCUB115-300-R25**

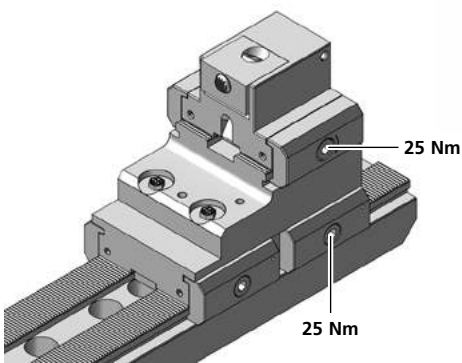
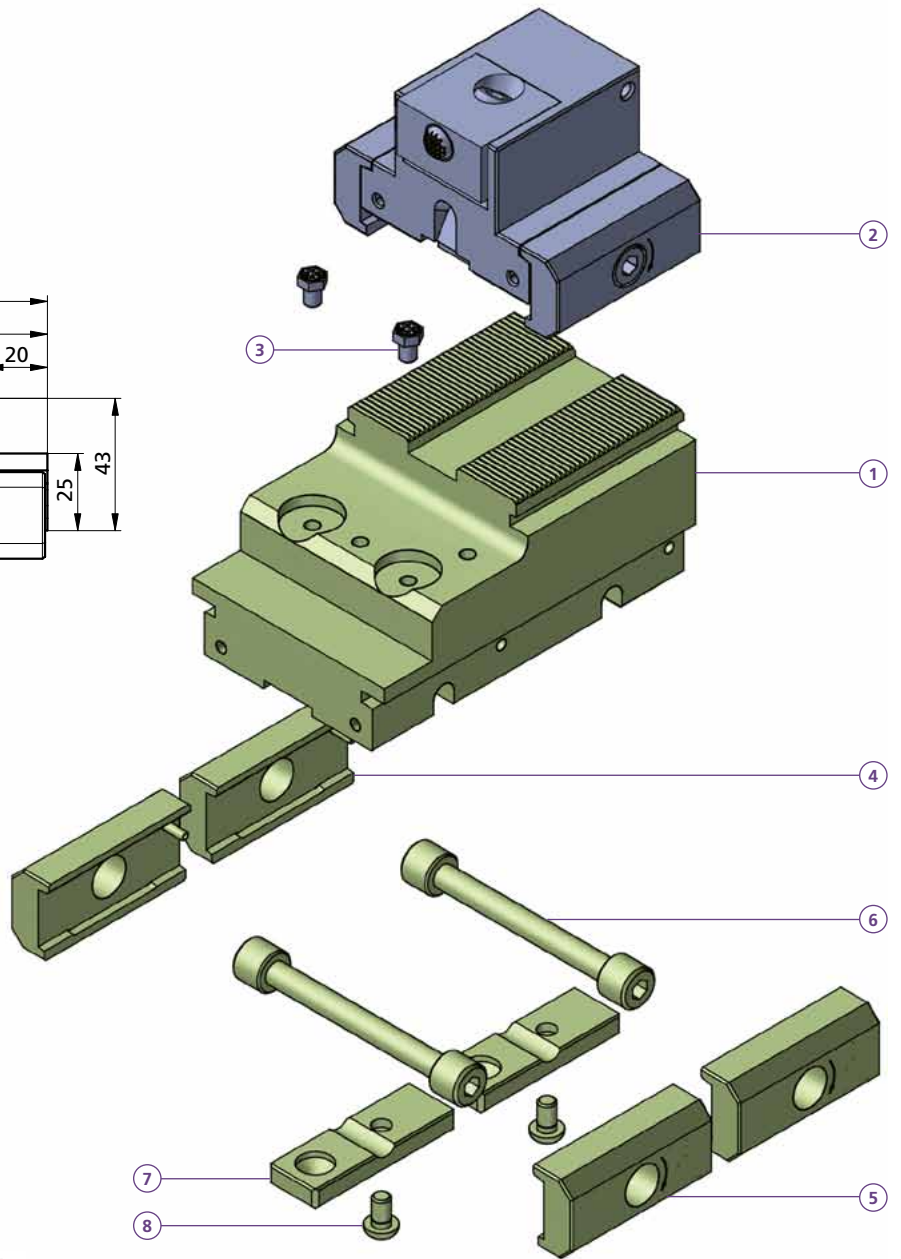
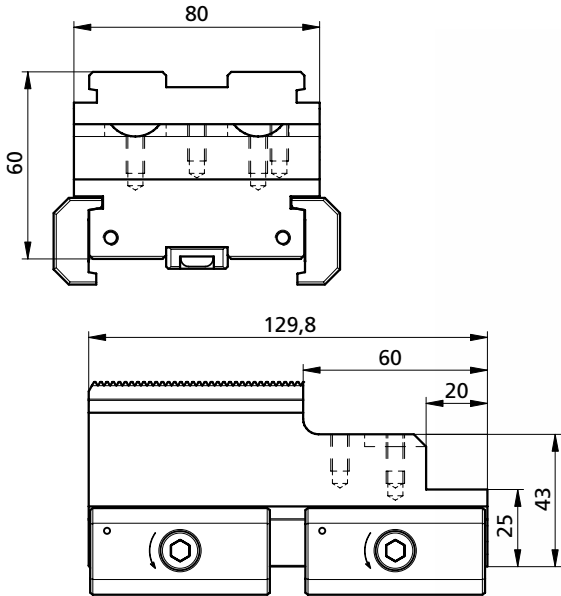

PCUB60-70-130	
①	1x TK130707
②	1x PS1F43N49-60
③	2x CCHMR
④	2x PCSP60L
⑤	2x PCSP60R
⑥	2x PCS14
⑦	2x PCGU2049
⑧	2x M6X8ISO7380
kg	~4,3

p. 64

Zubehör / Accessories p. 337

Bestellbeispiel / Ordering example: PCUB60-70-130

Separat bestellen / Separate order



# Schräge Basisschiene für 5-Achsenmaschinen

## Slanted base rail for 5-axes machines

PCB50207W25 25°



powerCLAMP

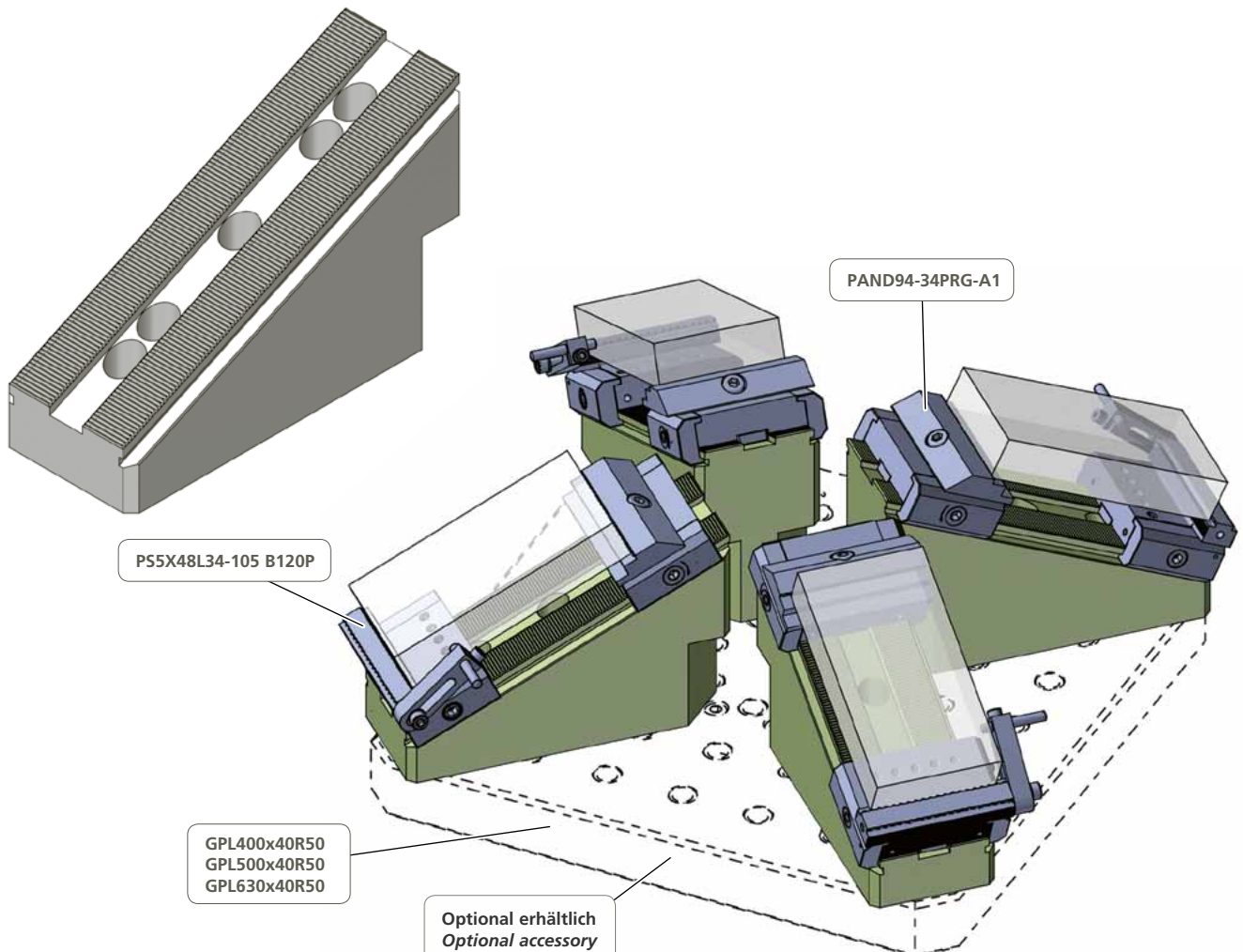
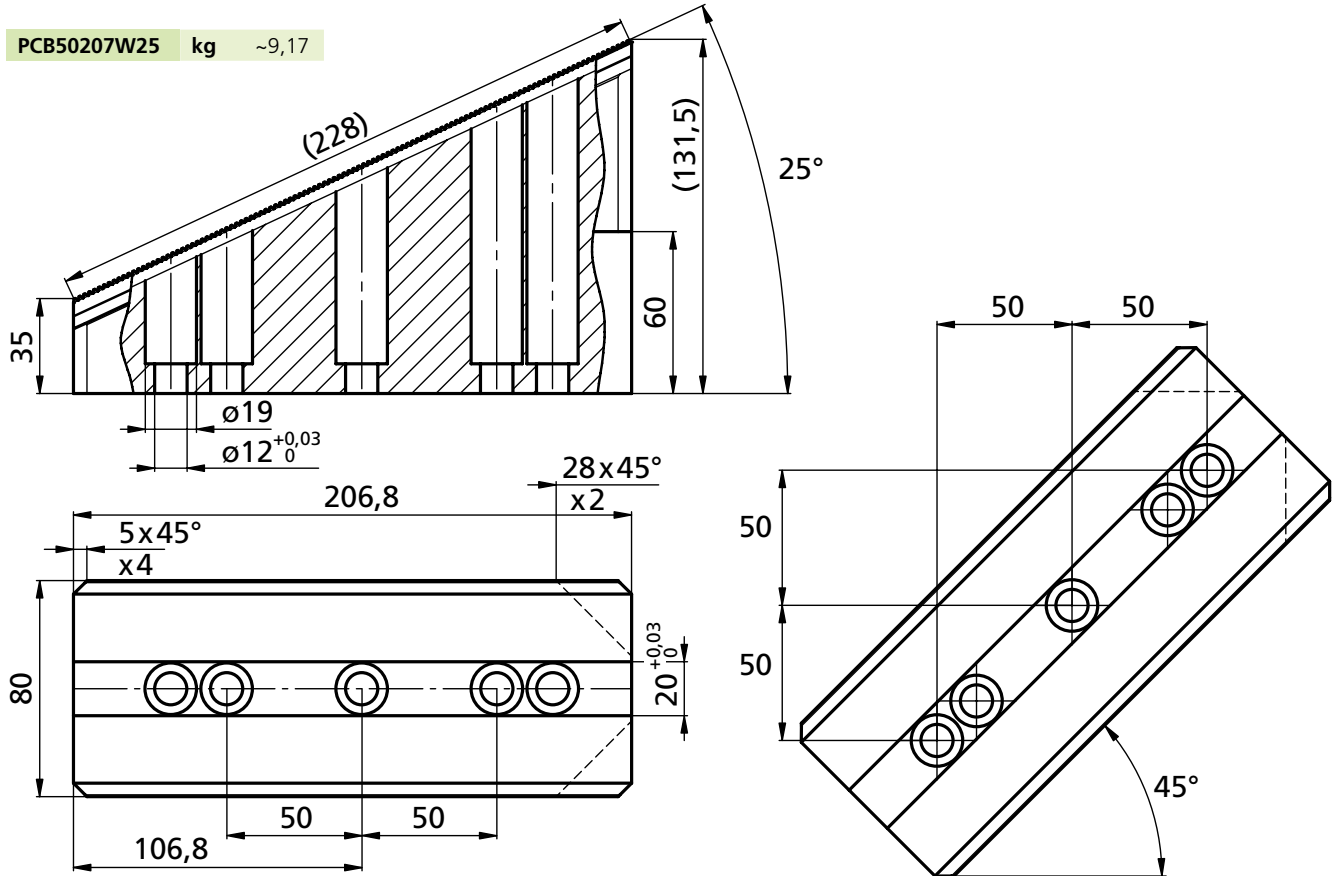

Bestellbeispiel / Ordering example: PCB50207W25

Separat bestellen / Separate order

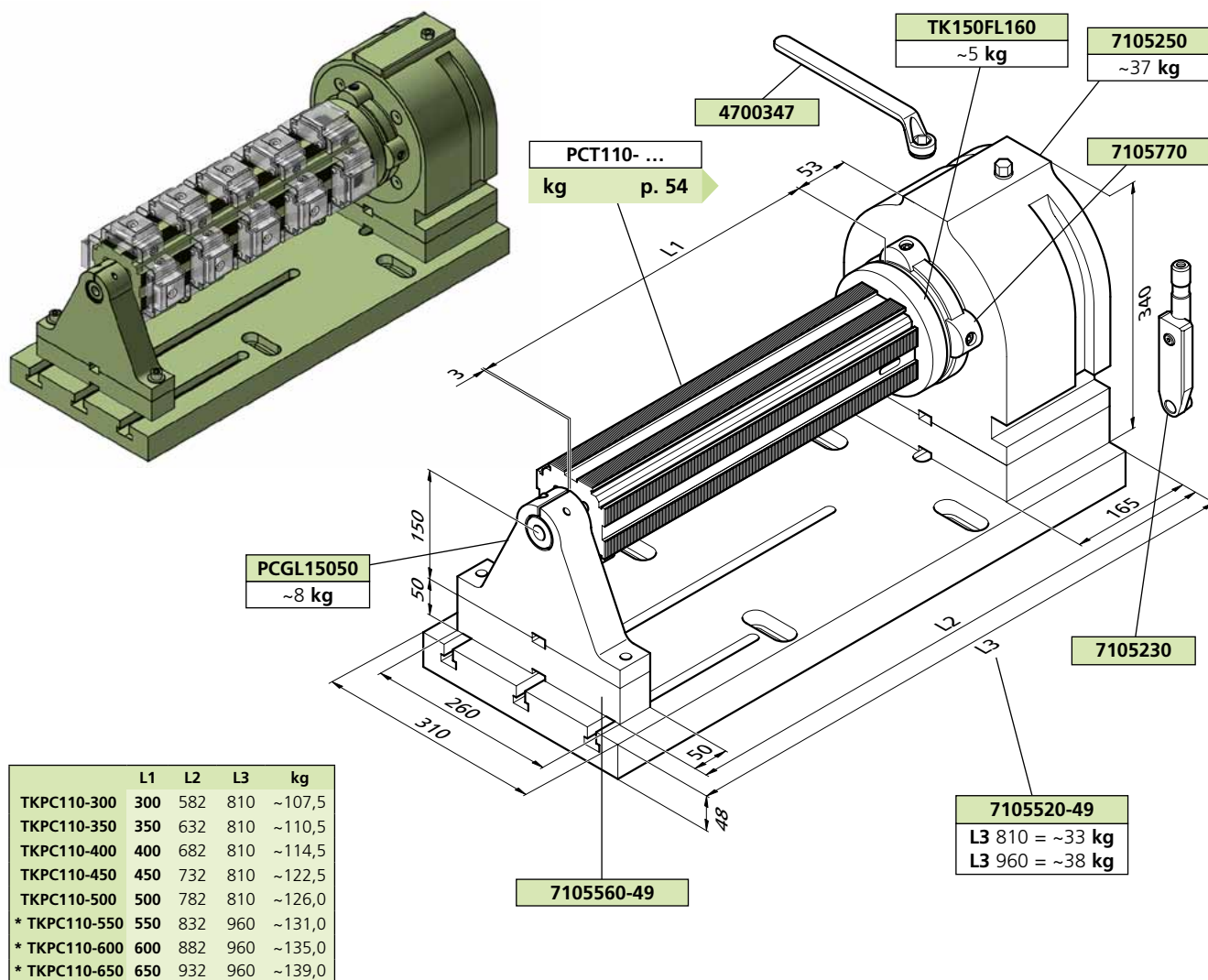

\* Entspricht nicht der Abbildung  
Does not correspond to the illustration

Bestellbeispiel / Ordering example: TKPC110-300







### Störkreis für Balken zu Teilapparat

Workpiece diameter for monobloc Power Clamp for 4th-axis

L	kg	Ø D			
PCT110-300	~24,5	255	241	211	224
B=110x110					
PCT110-350	~27,5	255	241	211	224
B=110x110					
PCT110-400	~31,5	255	241	211	224
B=110x110					
PCT110-450	~35,5	255	241	211	224
B=110x110					
PCT110-500	~39,5	255	241	211	224
B=110x110					
PCT110-550	~43,0	255	241	211	224
B=110x110					
PCT110-600	~47,0	255	241 <td 211	224	
B=110x110					
PCT110-650	~51,0	255	241	211	224
B=110x110					
PCT110-700	~55,2	255	241	211	224
B=110x110					

L	kg	Ø D		
PCMT150-700	~83	238	266	278
B=150x150				
PCMT150-750	~89	238	266	278
B=150x150				
PCMT150-800	~95	238	266	278
B=150x150				
PCMT150-850	~101	238	266	278
B=150x150				

- PS1R43N49-B60
- PS1R94N34-B80
- PS1R94N49-B90
- PS1R125N49-B95

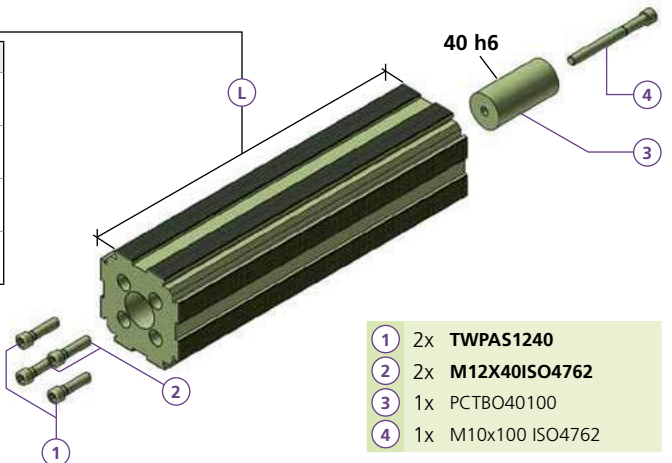

- 1 2x TWPAS1240
- 2 2x M12X40ISO4762
- 3 1x PCTBO40100
- 4 1x M10x100 ISO4762

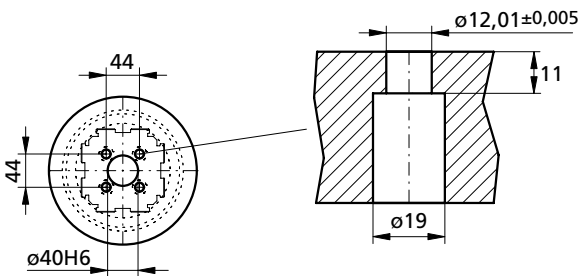

Monobloc powerCLAMP 110 x 110 x ...

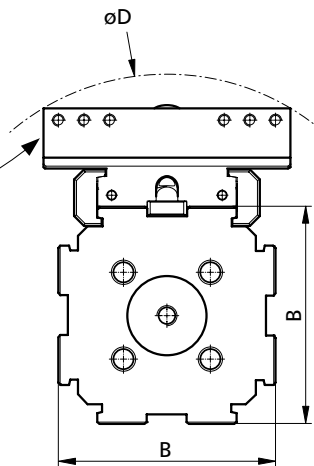

Bestellbeispiel / Ordering example: PCT110-500

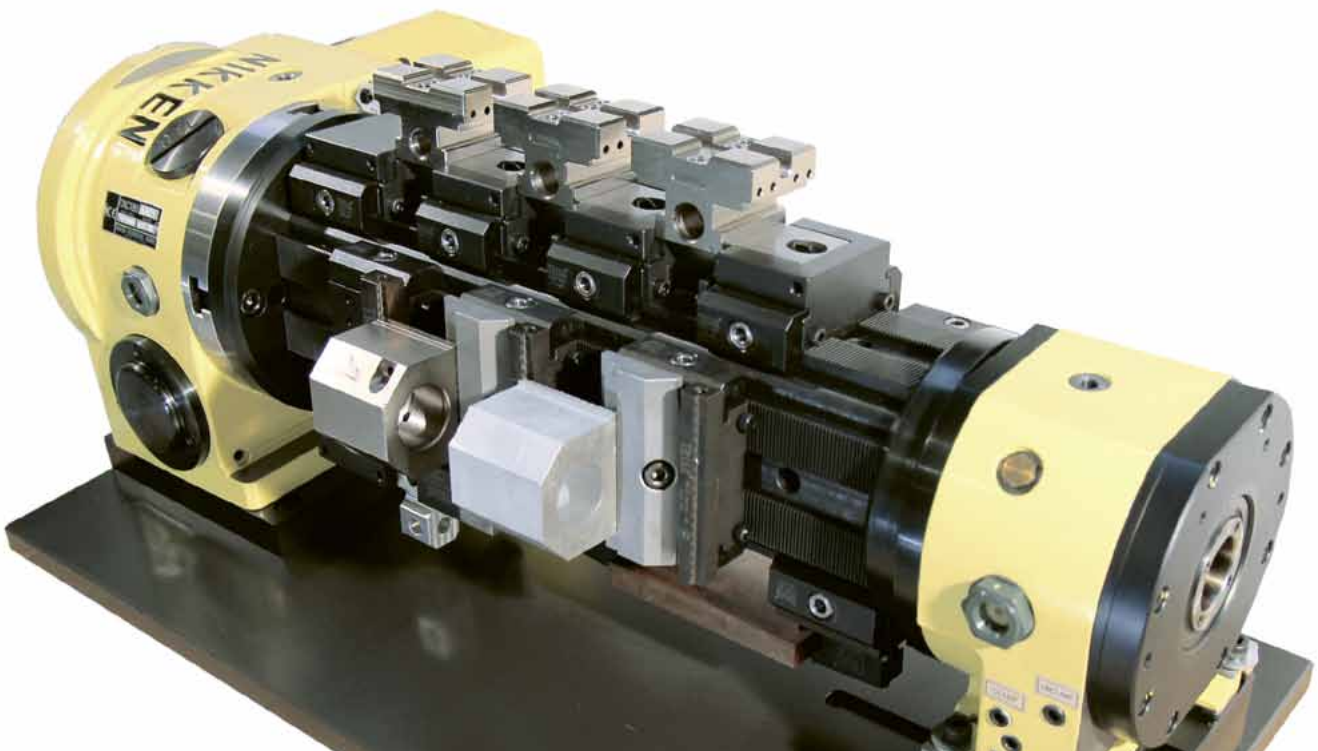



 powerCLAMP

 microCLAMP

 powerCLAMP

 triCENTRO

 microCLAMP





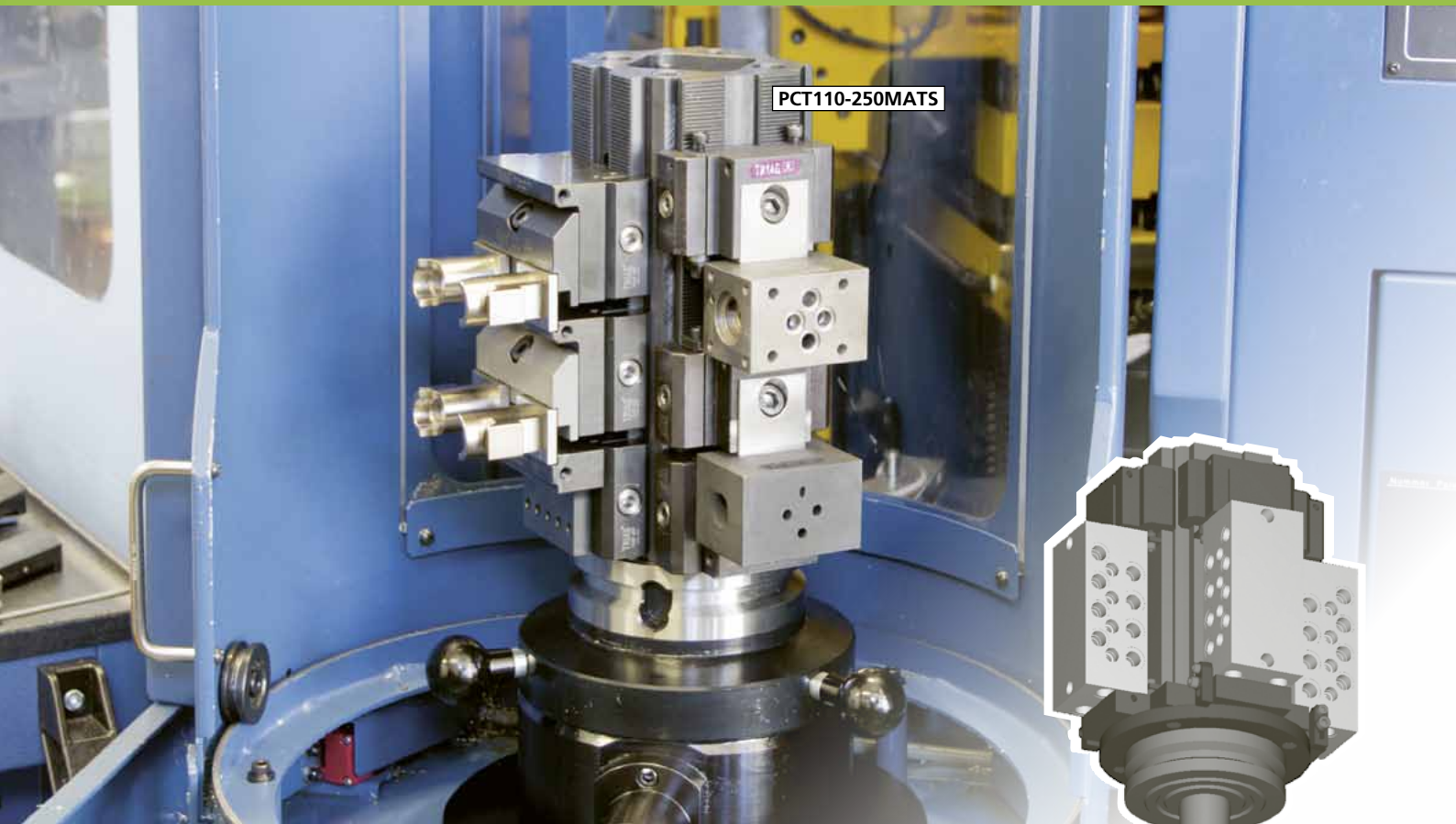

PCT110-250MATS

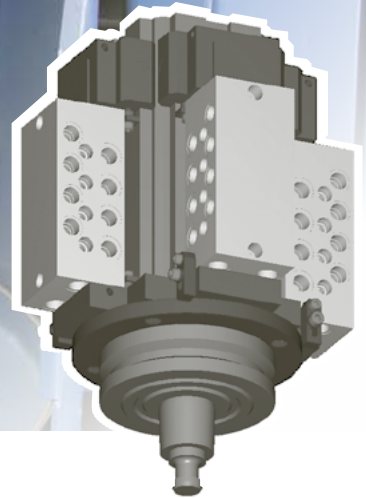

**Störkreis für MATS-Spanntürme**  
**Workpiece diameter for MATS clamping towers**

	H	kg	Ø D			
PCT110-250MATS	250	~20	255	241	211	224
PCT110-300MATS	300	~24	255	241	211	224
PCT7280232MATS	232	~11	211	195	161	176
PCT155-290-3MATS	290	~28,8	243	229	202	219
GPL160MATS	20	~2,2				

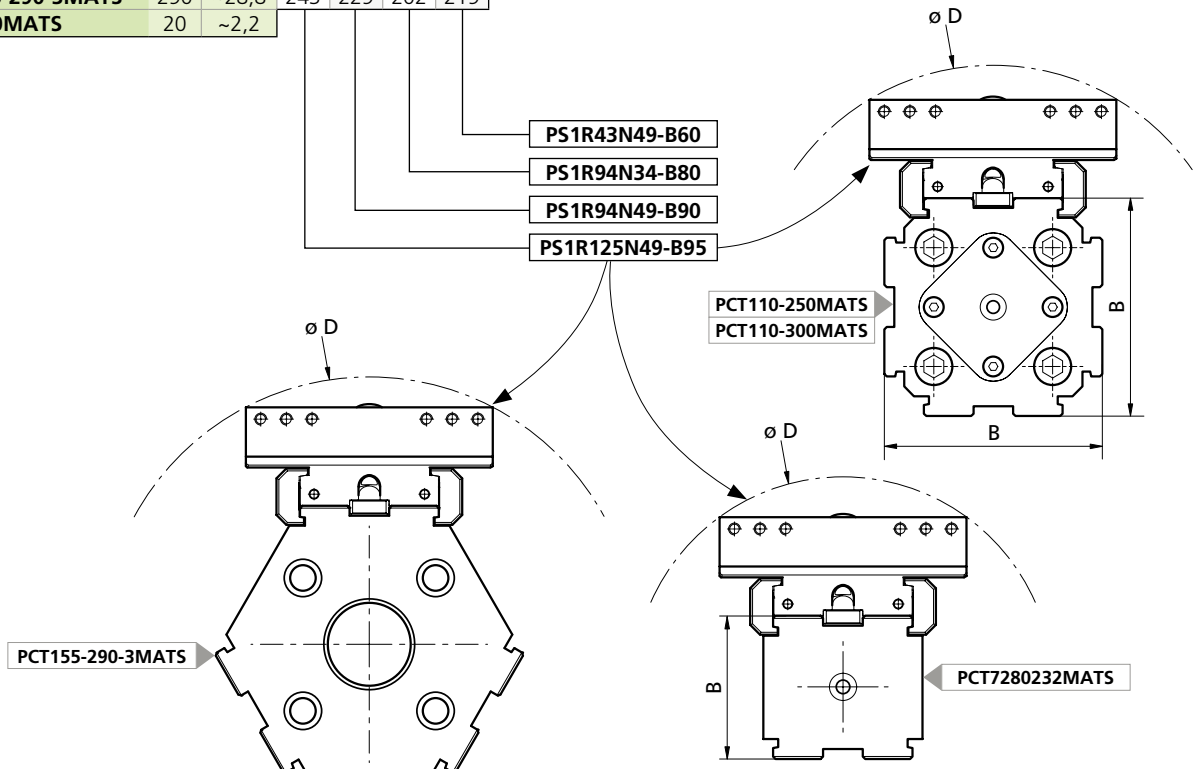

Bestellbeispiel / Ordering example: PCT110-250MATS

PCT110-250MATS  
PCT110-300MATS  
PCT155-290-3MATS

PCT7280232MATS  
GPL160MATS



powerCLAMP

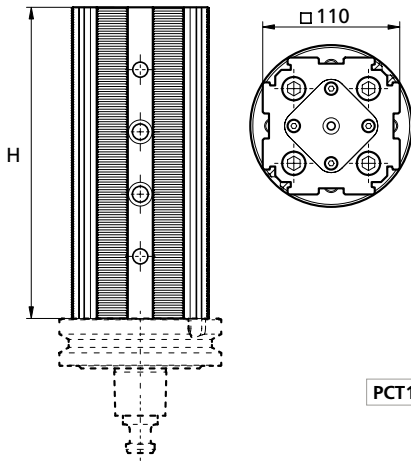

PCT110-250MATS

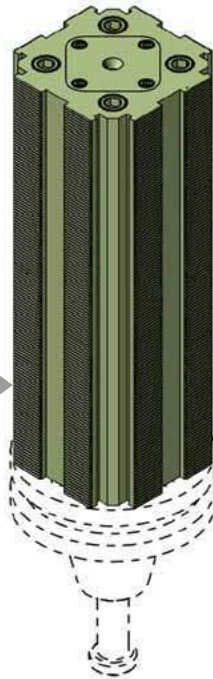

	H	kg
PCT110-250MATS	250	~20
PCT110-300MATS	300	~24

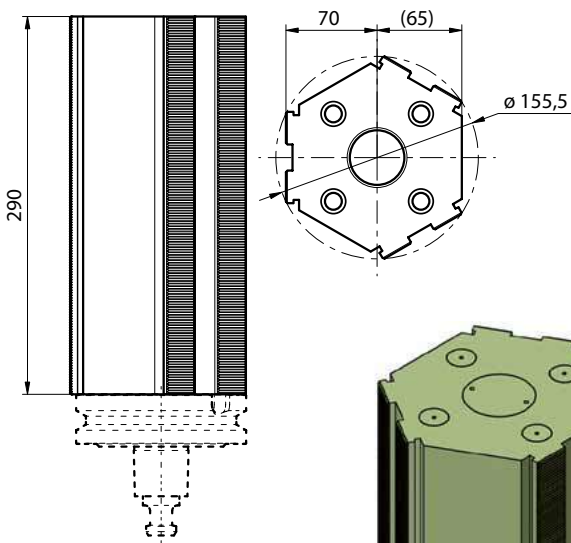

	H	kg
PCT155-290-3MATS	290	~28,8

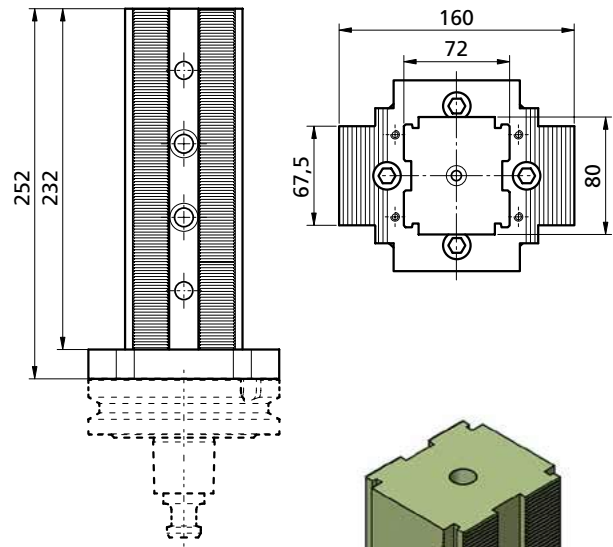

PCT7280232MATS

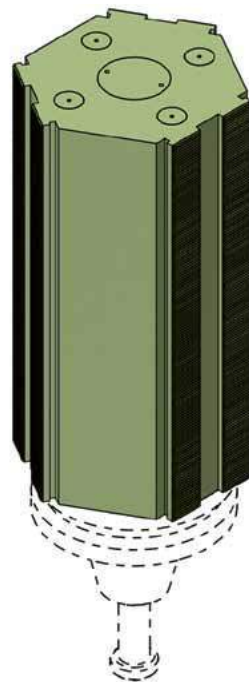

GPL160MATS

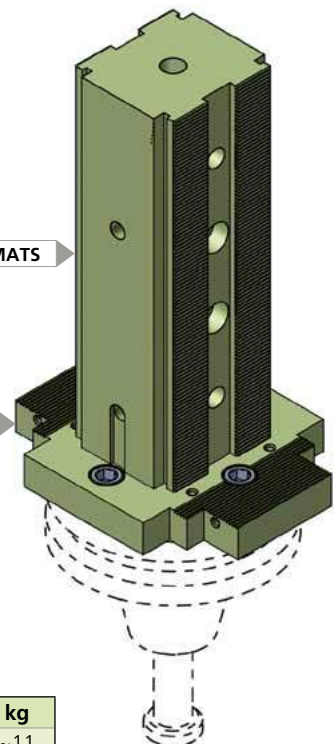

	H	kg
PCT7280232MATS	232	~11
GPL160MATS	20	~2,2

Separat bestellen / Separate order



## ...X PCSET18-650A 01

Stellen Sie Ihre eigenen Sets zusammen / Set up your own starter kits

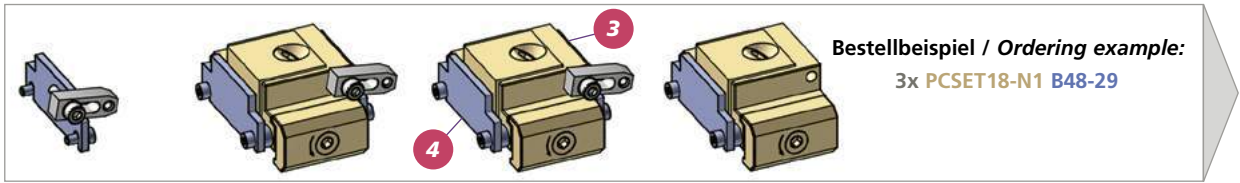

Bestellbeispiel / Ordering example:  
3x PCSET18-N1 B48-29

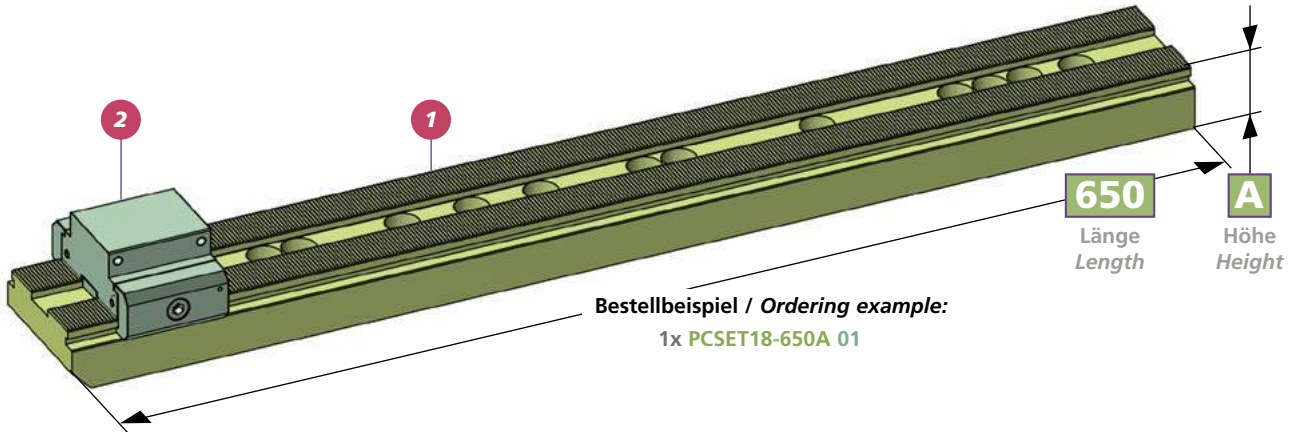

Bestellbeispiel / Ordering example:  
1x PCSET18-650A 01

Zu jeder Basisschiene gehört 1 Anschlagmodul «Tabelle 2» nach Ihrer Wahl!  
To each base rail one end module «table 2» of your choice is included!

Basisschienen / Base-rails	<b>PCSET18-250A</b> PCB2550250	<b>PCSET18-500A</b> PCB4050500	<b>PCSET18-700A</b> PCB4050700	A=H35 
	<b>PCSET18-350A</b> PCB4050350	<b>PCSET18-550A</b> PCB4050550	<b>PCSET18-750A</b> PCB4050750	
	<b>PCSET18-400A</b> PCB4050400	<b>PCSET18-600A</b> PCB4050600	<b>PCSET18-800A</b> PCB4050800	
	<b>PCSET18-450A</b> PCB4050450	<b>PCSET18-650A</b> PCB4050650		
	<b>PCSET18-320B</b> PCB50-320H60	<b>PCSET18-650B</b> PCB100-650H60		B=H60 
	<b>PCSET18-400B</b> PCB100-400H60	<b>PCSET18-690B</b> PCB100-690H60		
	<b>PCSET18-500B</b> PCB100-500H60	<b>PCSET18-850B</b> PCB100-850H60		
	<b>PCSET18-600B</b> PCB100-600H60			

Anschlagmodule / End modules	Breite / Width 48mm		Breite / Width 78mm		Breite / Width 94mm	
	<b>PAND48-34</b> 01 H=34	<b>PAND48-49</b> 02 H=49	<b>PAND78-34</b> 05 H=34	<b>PAND78-49</b> 06 H=49	<b>PAND94-34</b> 07 H=34	<b>PAND94-49</b> 08 H=49
	prägen / stamping				prägen / stamping	
	<b>PAND48-34PRF-A1</b> 03 H=34	<b>PAND48-49PRF-A1</b> 04 H=49			<b>PAND94-34PRF-A1</b> 09 H=34	<b>PAND94-49PRF-A1</b> 10 H=49



...X

PCSET18-N1

B48-29

3

Niederzugspannmodule / Pull down clamp modules

Breite / Width 48mm		Breite / Width 78mm		Breite / Width 94mm	
 PS1 R 48N34 B80N <b>PCSET18-N1</b> H=34	 PS1 R 48N49 B80N <b>PCSET18-N2</b> H=49	 PS1 R 78N49 B90R78 <b>PCSET18-N5</b> H=49	 PS1 F 78N49 B90F78 <b>PCSET18-N6</b> H=49	 PS1 R 94N49 B90 <b>PCSET18-N7</b> H=49	 PS1 F 94N49 B90 <b>PCSET18-N8</b> H=49
 PS1 F 48N34 B80N <b>PCSET18-N3</b> H=34	 PS1 F 48N49 B80N <b>PCSET18-N4</b> H=49			 PS1 R 94N49 B93 <b>PCSET18-N9</b> H=49	

Linearspannmodule / Linear clamp modules

Breite / Width 48mm		Breite / Width 78mm		Breite / Width 94mm	
prägen / stamping					
 PS1 PF 48L34 B115P <b>PCSET18-L1</b> H=34	 PS1 PF 48L49 B115P <b>PCSET18-L2</b> H=49	 PS1 R 78L34 B141 <b>PCSET18-L5</b> H=34	 PS1 F 78L34 B140 <b>PCSET18-L6</b> H=34	 PS1 PF 94L34 B120P <b>PCSET18-L9</b> H=34	 PS1 PF 94L49 B120P <b>PCSET18-L11</b> H=49
 PS1 R 48L49 B106 <b>PCSET18-L3</b> H=49	 PS1 F 48L49 B105 <b>PCSET18-L4</b> H=49	 PS1 R 78L49 B141 <b>PCSET18-L7</b> H=49	 PS1 F 78L49 B140 <b>PCSET18-L8</b> H=49	 PS1 R 94L34 B111 <b>PCSET18-L12</b> H=34	 PS1 F 94L34 B110 <b>PCSET18-L13</b> H=34
 PS1 R 48L34 B106 <b>PCSET18-L16</b> H=34	 PS1 F 48L34 B105 <b>PCSET18-L17</b> H=34	* Bei jedem Spannmodule sind 2 Parallelunterlagen nach Ihrer Wahl und 1 Fräsanschlag enthalten		 PS1 R 94L49 B111 <b>PCSET18-L14</b> H=49	 PS1 F 94L49 B110 <b>PCSET18-L15</b> H=49

Each clamp module included 2 parallels of your choice and 1 milling buffer

4

Inkl. 2 x Parallelunterlage  
Incl. 2 x Steel parallels

Breite / Width 48mm	Breite / Width 78mm	Breite / Width 94mm	Fräsanschlag Milling buffer																																																								
 PCU29047	 PCU39077	 PCU29093	1 x Inklusive / Included  FA1240																																																								
<table border="1"> <thead> <tr> <th>B48-</th> <th>H*</th> </tr> </thead> <tbody> <tr><td>PCU 20</td><td>047</td></tr> <tr><td>PCU 24</td><td>047</td></tr> <tr><td>PCU 29</td><td>047</td></tr> <tr><td>PCU 31</td><td>047</td></tr> <tr><td>PCU 34</td><td>047</td></tr> <tr><td>PCU 39</td><td>047</td></tr> <tr><td>PCU 44</td><td>047</td></tr> <tr><td>PCU 46</td><td>047</td></tr> </tbody> </table>	B48-	H*	PCU 20	047	PCU 24	047	PCU 29	047	PCU 31	047	PCU 34	047	PCU 39	047	PCU 44	047	PCU 46	047	<table border="1"> <thead> <tr> <th>B78-</th> <th>H*</th> </tr> </thead> <tbody> <tr><td>PCU 20</td><td>077</td></tr> <tr><td>PCU 24</td><td>077</td></tr> <tr><td>PCU 29</td><td>077</td></tr> <tr><td>PCU 31</td><td>077</td></tr> <tr><td>PCU 34</td><td>077</td></tr> <tr><td>PCU 39</td><td>077</td></tr> <tr><td>PCU 44</td><td>077</td></tr> </tbody> </table>	B78-	H*	PCU 20	077	PCU 24	077	PCU 29	077	PCU 31	077	PCU 34	077	PCU 39	077	PCU 44	077	<table border="1"> <thead> <tr> <th>B94-</th> <th>H*</th> </tr> </thead> <tbody> <tr><td>PCU 14</td><td>093</td></tr> <tr><td>PCU 20</td><td>093</td></tr> <tr><td>PCU 24</td><td>093</td></tr> <tr><td>PCU 29</td><td>093</td></tr> <tr><td>PCU 31</td><td>093</td></tr> <tr><td>PCU 34</td><td>093</td></tr> <tr><td>PCU 39</td><td>093</td></tr> <tr><td>PCU 44</td><td>093</td></tr> <tr><td>PCU 46</td><td>093</td></tr> <tr><td>PCU 47</td><td>093</td></tr> </tbody> </table>	B94-	H*	PCU 14	093	PCU 20	093	PCU 24	093	PCU 29	093	PCU 31	093	PCU 34	093	PCU 39	093	PCU 44	093	PCU 46	093	PCU 47	093	
B48-	H*																																																										
PCU 20	047																																																										
PCU 24	047																																																										
PCU 29	047																																																										
PCU 31	047																																																										
PCU 34	047																																																										
PCU 39	047																																																										
PCU 44	047																																																										
PCU 46	047																																																										
B78-	H*																																																										
PCU 20	077																																																										
PCU 24	077																																																										
PCU 29	077																																																										
PCU 31	077																																																										
PCU 34	077																																																										
PCU 39	077																																																										
PCU 44	077																																																										
B94-	H*																																																										
PCU 14	093																																																										
PCU 20	093																																																										
PCU 24	093																																																										
PCU 29	093																																																										
PCU 31	093																																																										
PCU 34	093																																																										
PCU 39	093																																																										
PCU 44	093																																																										
PCU 46	093																																																										
PCU 47	093																																																										



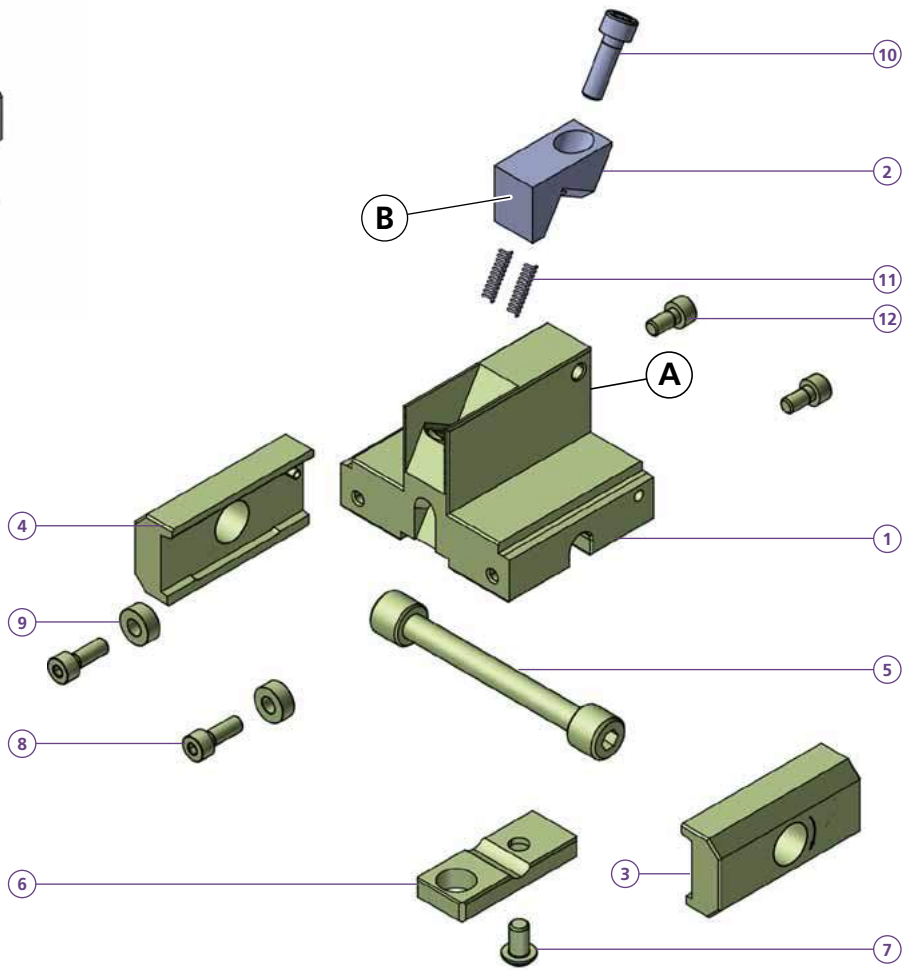
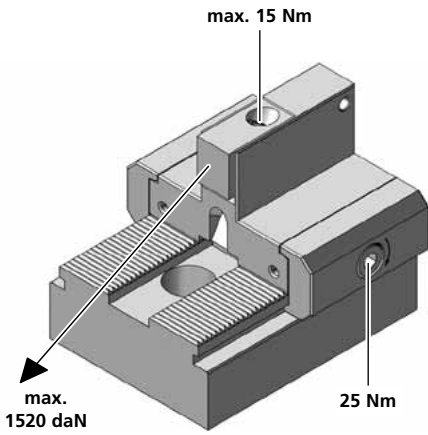
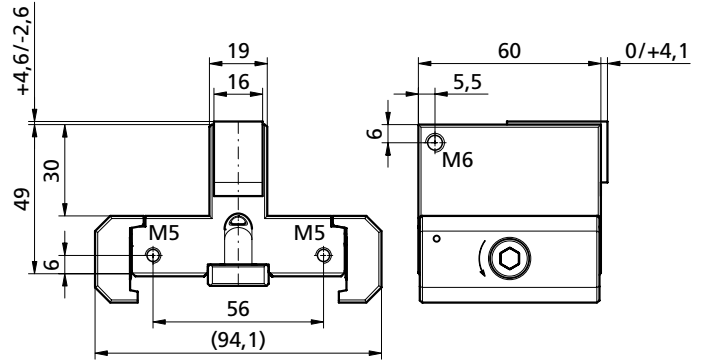
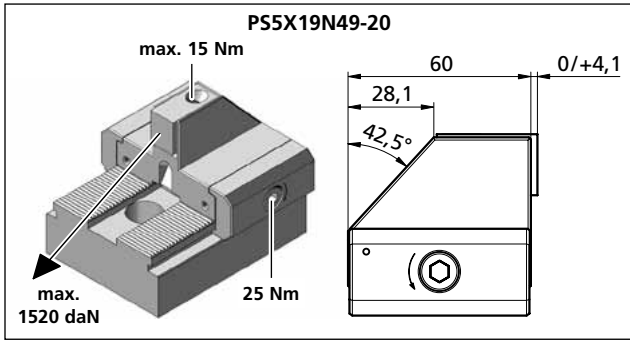

	<b>PS5X19N49-20</b>
1	1x TF140449
9	2x PCD005
8	2x M5X14ISO4762
kg	~1,1
	<b>PS1F19N49-20</b>
1	1x TF150961
	<b>PS1R19N49-20</b>
1	1x TF140448
2	1x
3	1x PCSP60R
4	1x PCSP60L
5	1x PCS14
6	1x PCGU2049
7	1x M6X8ISO7380
8	2x M5X14ISO4762
9	2x PCD005
10	1x M6X20ISO4762
11	2x FED0418
12	2x M5X10ISO4762
kg	~1,2

	<b>B20</b>	<b>B21</b>	<b>B22</b>
C	16	16	16
H	20	20	20
L	19	19	19
D	6,5	6,5	6,5
ø	12	12	12
i	HV700	HV700	*
	x0,2mm	x0,2mm	
kg	~0,06	~0,06	~0,06

Bestellbeispiel / Ordering example: 1x PS1R19N49-20 & 1x B21

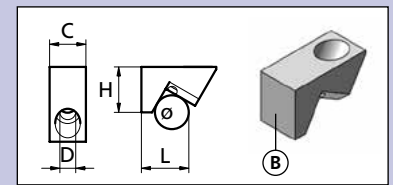

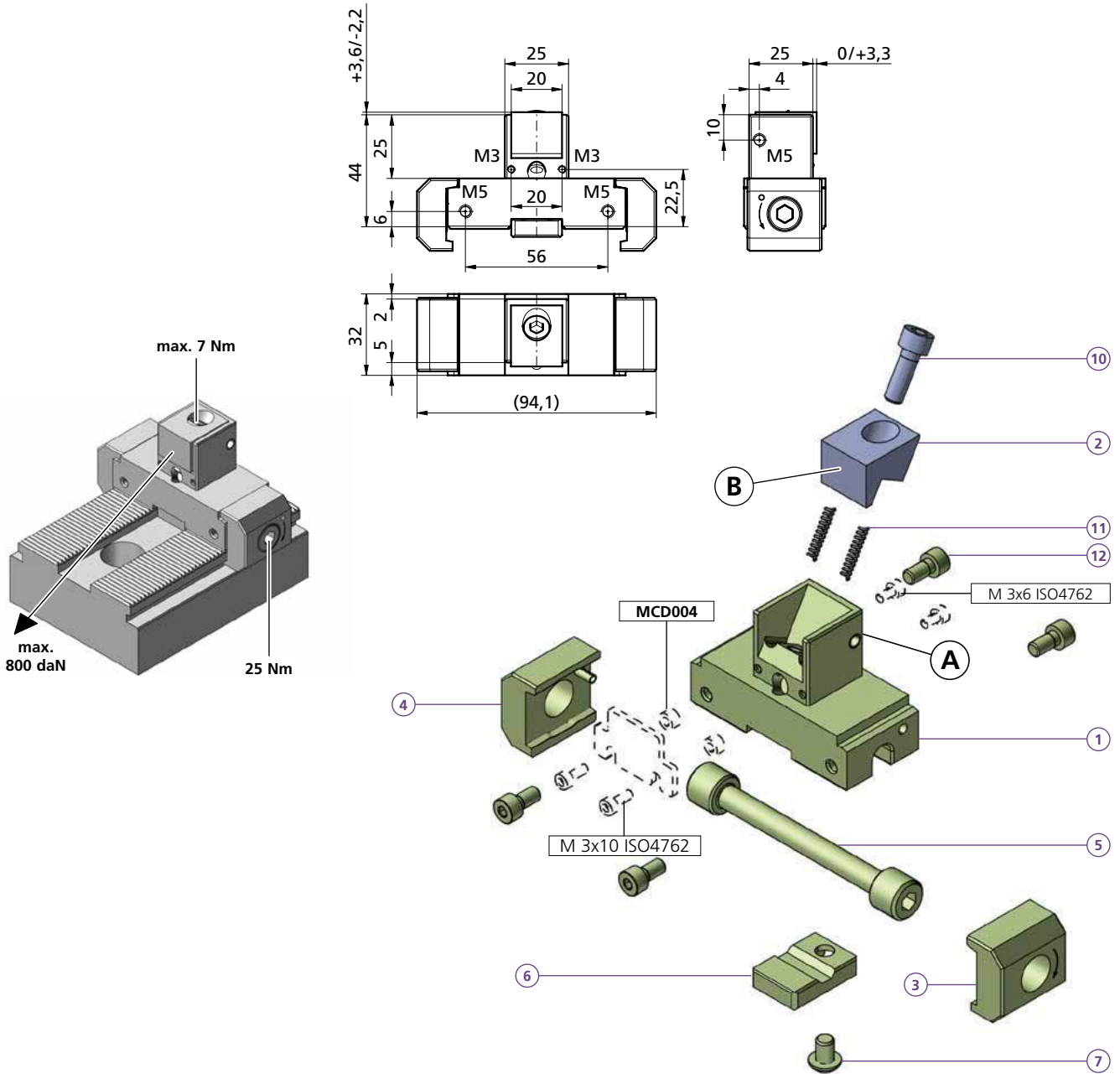

<b>PS1F25N44-13</b>	
①	1x TF150960
<b>PS1R25N44-13</b>	
①	1x TF140450
②	1x
③	1x PCSP30R
④	1x PCSP30L
⑤	1x PCS14
⑥	1x PCGU2030
⑦	1x M6X8ISO7380
⑩	1x M6X16ISO4762
⑪	2x FED03018
⑫	4x M5X10ISO4762
kg	~0,6

<b>Bestellbeispiel / Ordering example: 1x PS1R25N44-13 &amp; 1x B14</b>				
	<b>B13</b>	<b>B14</b>	<b>B15</b>	<b>B16</b>
③	20	20	20	20
④	16	16	16	16
⑤	13,8	13,8	13,8	19
⑥	6,5	6,5	6,5	6,5
⑦	10	10	10	10
i	HV700	HV700	*	*
	x0,2mm	x0,2mm		
kg	~0,05	~0,05	~0,05	~0,06

	H	B	N	kg
MCU11037	11	23	2	~0,004
MCU15037	15	23	2	~0,006
MCU18037	18	23	2	~0,008
MCU20037	20	23	2	~0,008
MCU22537	22,5	23	2	~0,008
	2x	<b>M3X10ISO4762</b>		
	2x	<b>M3X6ISO4762</b>		
	2x	MCD 004		

\* = weicher Stahl / soft steel





PS1R/F26N49-26

PS5X26N49-26

powerCLAMP

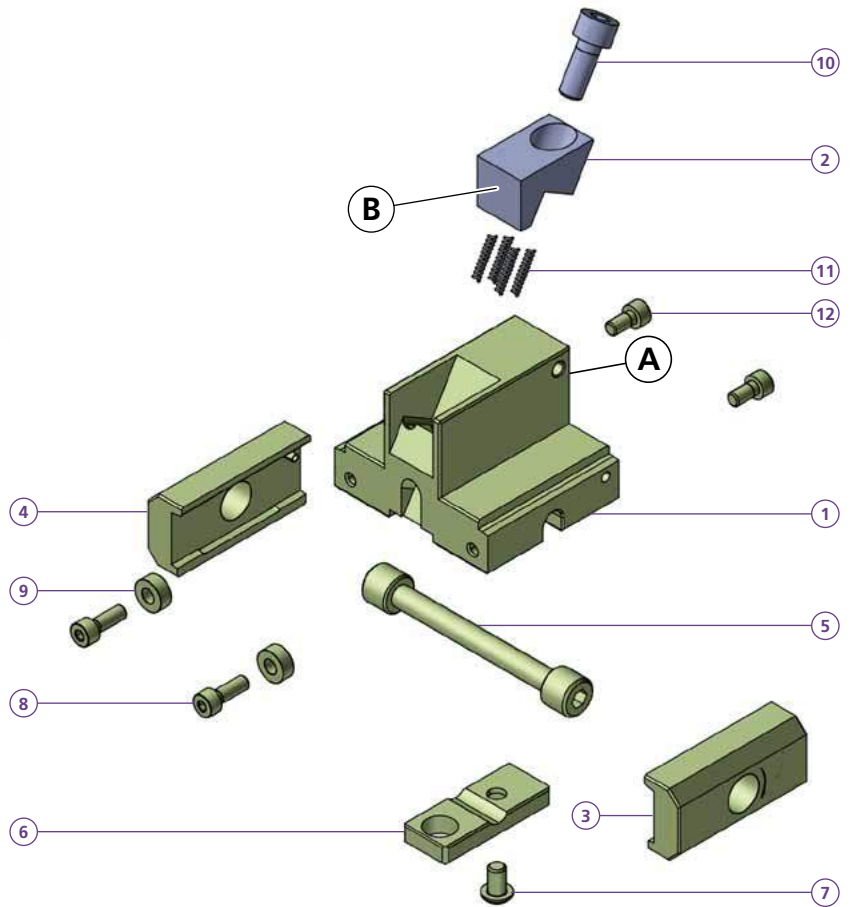
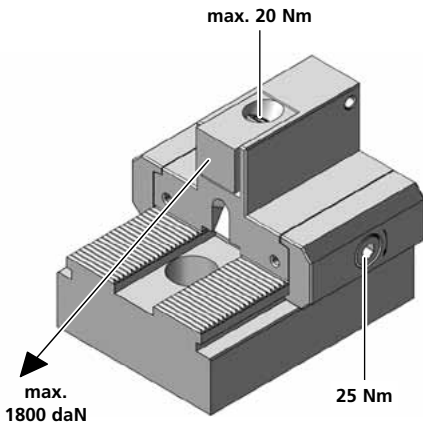
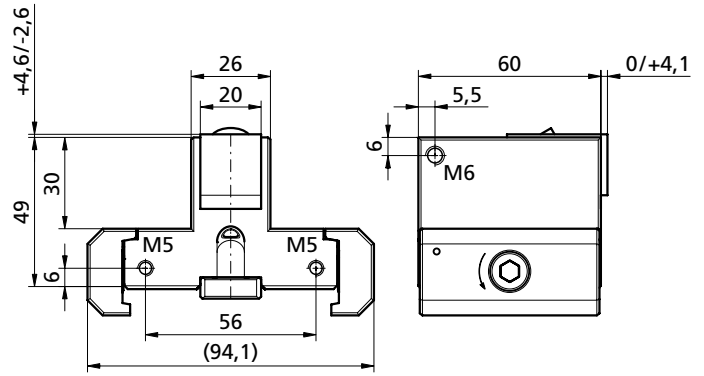
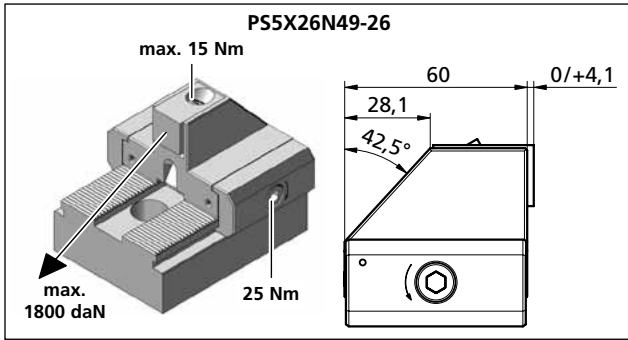

<b>PS5X26N49-26</b>	
1	1x TF140453
9	2x PCD005
8	2x M5X14ISO4762
kg	~1,1
<b>PS1F26N49-26</b>	
1	1x TF140451
<b>PS1R26N49-26</b>	
1	1x TF140452
2	1x
3	1x PCSP60R
4	1x PCSP60L
5	1x PCS14
6	1x PCGU2049
7	1x M6X8ISO7380
8	2x M5X14ISO4762
9	2x PCD005
10	1x M8X20ISO4762
11	4x FED0418
12	2x M5X10ISO4762
kg	~1,2

<b>B</b>	<b>B26</b>	<b>B27</b>	<b>B28</b>
C	20	20	20
H	20	20	20
L	19	19	19
D	9	9	9
ø	12	12	12
i	HV700	HV700	*
	x0,2mm	x0,2mm	
kg	~0,07	~0,07	~0,07

Bestellbeispiel / Ordering example: 1x PS1R26N49-26 & 1x B26

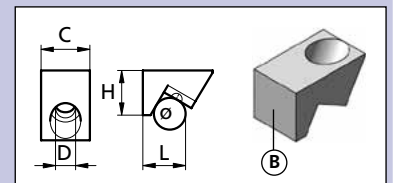

Separat bestellen / Separate order



PS1R/F34N49-45

PS5X34N49-45

powerCLAMP

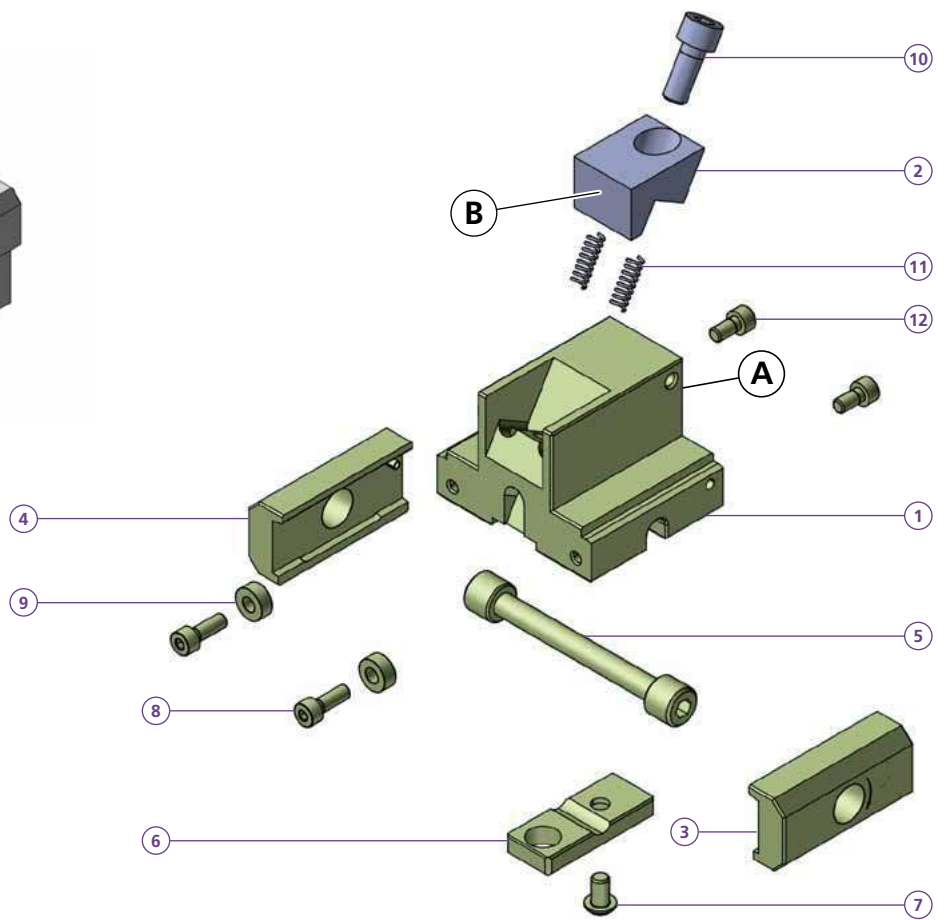
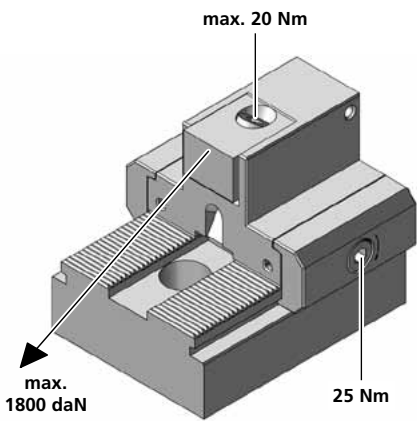
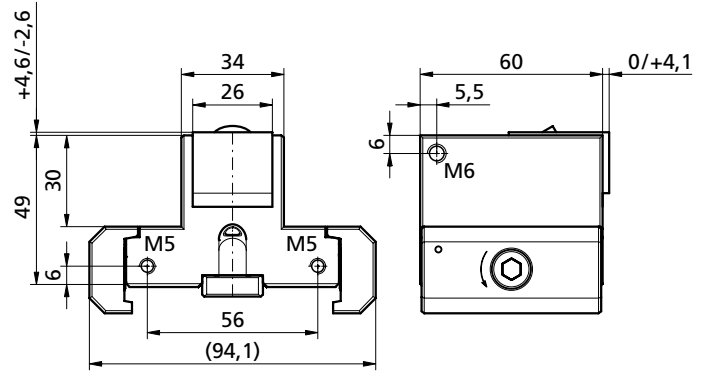
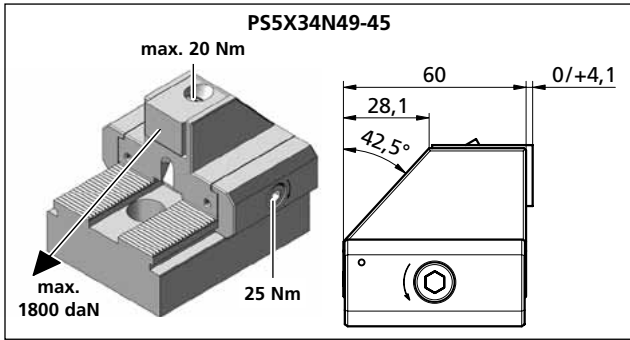

<b>PS5X34N49-45</b>	
1	1x TF140455
9	2x PCD005
8	2x M5X14ISO4762
kg	~1,2
<b>PS1F34N49-45</b>	
1	1x TF191071
<b>PS1R34N49-45</b>	
1	1x TF140454
2	1x
3	1x PCSP60R
4	1x PCSP60L
5	1x PCS14
6	1x PCGU2049
7	1x M6X8ISO7380
8	2x M5X14ISO4762
9	2x PCD005
10	1x M8X20ISO4762
11	2x FED0618
12	2x M5X10ISO4762
kg	~1,3

**Bestellbeispiel / Ordering example:** 1x **PS5X34N49-45** & 1x **B47HM**

	<b>B45</b>	<b>B46</b>	<b>B47</b>	<b>B47HM</b>
C	26	26	26	26
H	20	20	20	20
L	19	19	19,1	19,1
D	9	9	9	9
e	12	12	12	12
i	HV700	HV700	*	HM
	x0,2mm	x0,2mm		
kg	~0,1	~0,1	~0,1	~0,1

\* = weicher Stahl / soft steel

HM = Hartmetallbeschichtet / Carbide coated



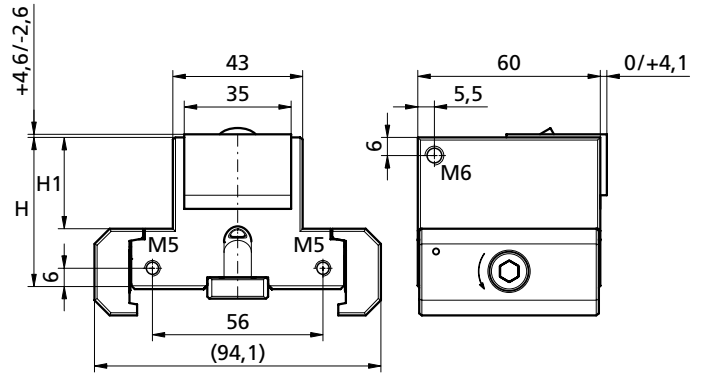
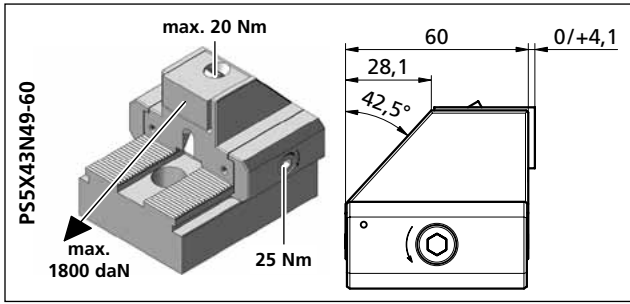

- PS5X43N49-60**
- 1x TF140458
  - 2x PCD005
  - 2x M5X14ISO4762
- kg ~1,3
- PS1F43N49-60**
- 1x TF140456
- PS1R43N49-60**
- 1x TH160507
  - 1x \_\_\_\_\_
  - 1x PCSP60R
  - 1x PCSP60L
  - 1x PCS14
  - 1x PCGU2049
  - 1x M6X8ISO7380
  - 2x M5X14ISO4762
  - 2x PCD005
  - 1x M8X20ISO4762
  - 2x FED0618
  - 2x M5X10ISO4762
- H = 49  
H1 = 30  
kg ~1,4
- PS1F43N62-60**
- 1x TF140459
- PS1R43N62-60**
- 1x TF140460
- H = 62  
H1 = 43  
kg ~1,7

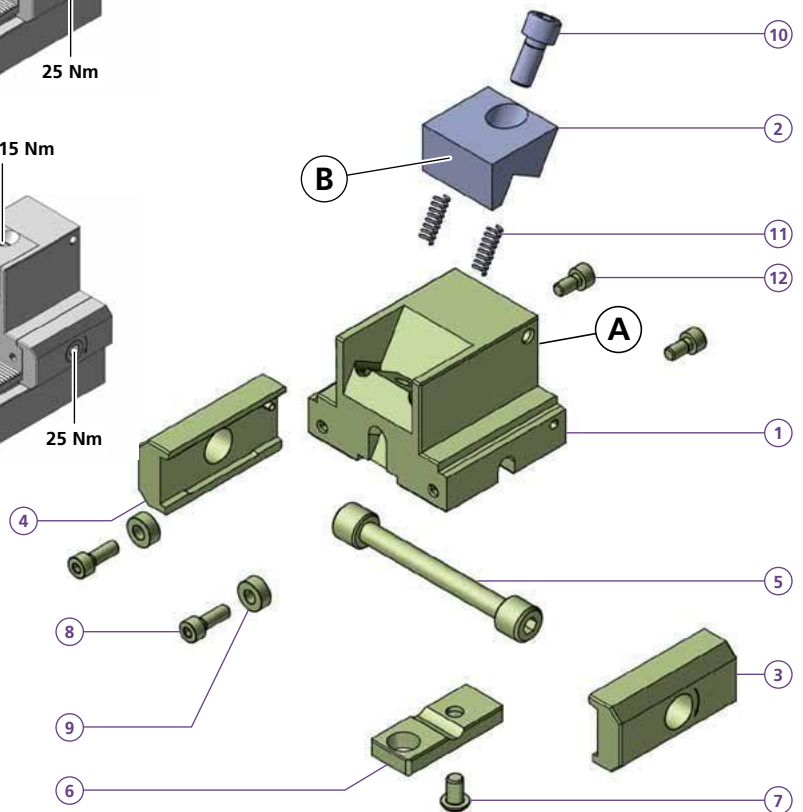
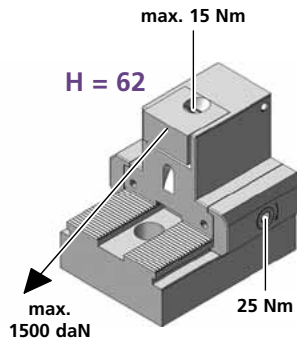
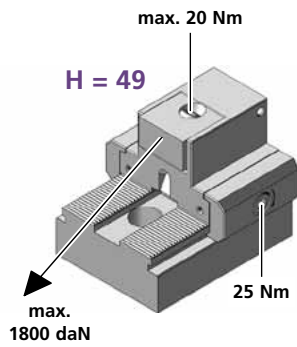

Bestellbeispiel / Ordering example: 1x PS1R43N49-60 & 1x B61

	B58	B60	B61	B62	B62HM	B65	B66	B67	B68	B69	B77	B79F	B79R
C	35	35	35	35	35	35	35	35	35	35	35	35	35
H	20	20	20	20	20	20	20	20	20	25	20	20	20
L	26	19	19	19	19	19	19	24	26	22	22	25	25
D	9	9	9	9	9	9	9	9	9	9	9	9	9
o	12	12	12	12	12	12	12	12	12	12	12	12	12
i	ALU	56HRC	56HRC	*	HM	HV700 x0,2mm	HV700 x0,2mm	HV700 x0,2mm	*	*	56HRC	HV700 x0,2mm	HV700 x0,2mm
kg	~0,07	~0,12	~0,12	~0,12	~0,12	~0,12	~0,12	~0,14	~0,15	~0,15	~0,12	~0,18	~0,18

**B69**  
M5X10ISO4762  
+11,5/-0,7  
0/+7

FED 0628

**B58**

**B60, B61, B62, B62HM**

**B65, B66, B67**

**B68**

**B77**

Spannbacke mit CCPDR  
Jaw with CCPDR

**B79F, B79R**

Separat bestellen / Separate order

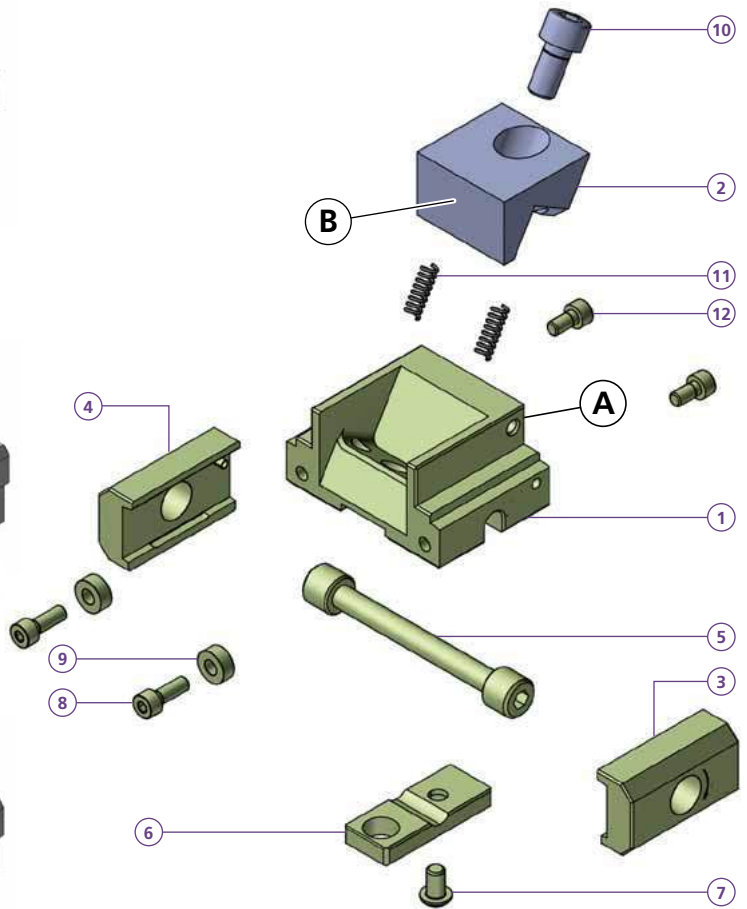
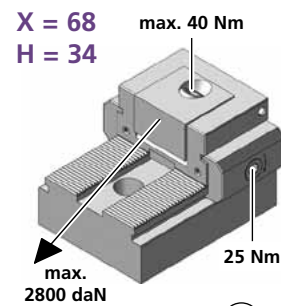
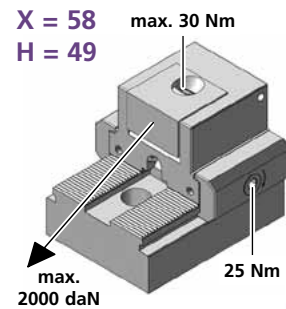
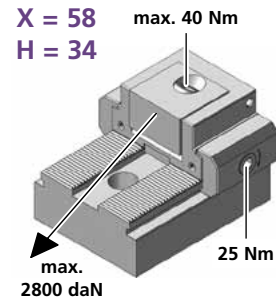
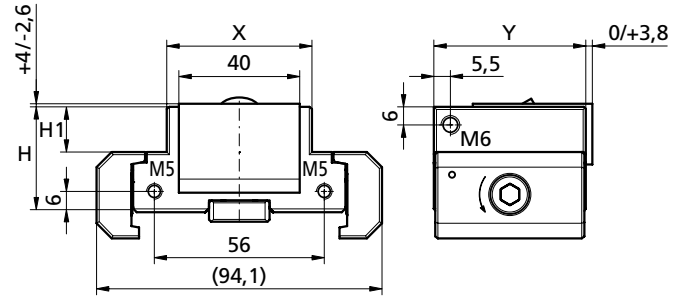
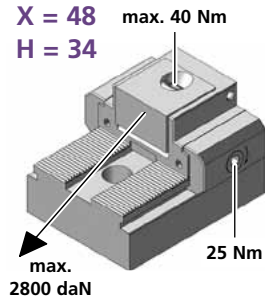

**PS1F48N34-80**

- 1 1x TF140461
- PS1R48N34-80**
- 1 1x TF140462
  - 2 1x
  - 3 1x PCSP50R
  - 4 1x PCSP50L
  - 5 1x PCS14
  - 6 1x PCGU2049
  - 7 1x M6X8ISO7380
  - 8 2x M5X14ISO4762
  - 9 2x PCD005
  - 10 1x M10X25ISO4762
  - 11 2x FED0618
  - 12 2x M5X10ISO4762
- X = 48  
H = 34  
H1 = 15  
Y = 50  
kg ~0,9

**PS1F58N34-80**

- 1 1x TF140463
- PS1R58N34-80**
- 1 1x TF140464
- X = 58  
H = 34  
H1 = 15  
Y = 50  
kg ~0,9

**PS1R58N49-80**

- 1 1x TK120129
  - 3 1x PCSP60R
  - 4 1x PCSP60L
- X = 58  
H = 49  
H1 = 30  
Y = 60  
kg ~1,6

**PS1F68N34-80**

- 1 1x TF140465
- PS1R68N34-80**
- 1 1x TF140466
- X = 68  
H = 34  
H1 = 15  
Y = 50  
kg ~1,0

**Bestellbeispiel / Ordering example: 1x PS1F68N34-80 & 1x B82HM**

	B80	B80N	B81	B82	B82L33	B82HM	B83	B84	B89F	B89R
C	40	40	40	40	40	40	40	40	40	40
H	25	25	25	25	25	25	25	25	25	25
L	22	22	22	22,2	33	22,2	22	26,3	29	29
D	11	11	11	11	11	11	11	11	11	11
ø	15	15	15	15	15	15	15	15	15	15
i	56HRC	HV700 x0,2mm	56HRC	*	*	56HRC	HV700 x0,2mm	*	HV700 x0,2mm	HV700 x0,2mm
kg	~0,2	~0,2	~0,2	~0,2	~0,28	~0,2	~0,2	~0,2	~0,24	~0,24

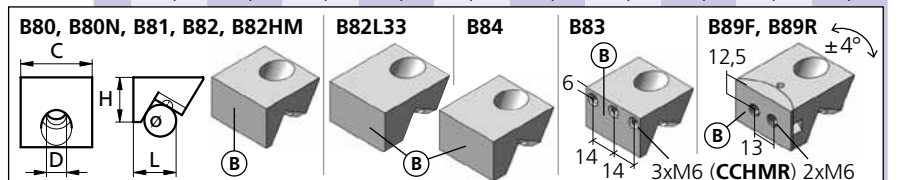

\* = weicher Stahl / soft steel

HM = Hartmetallbeschichtet / Carbide coated

Separat bestellen / Separate order



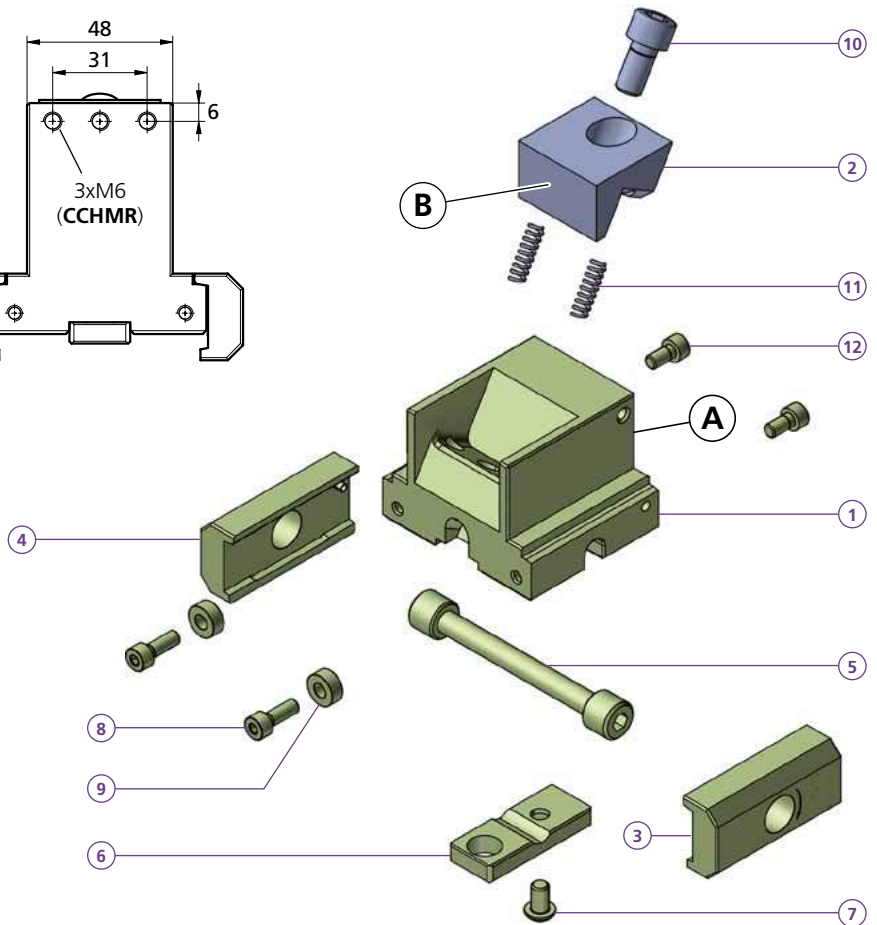
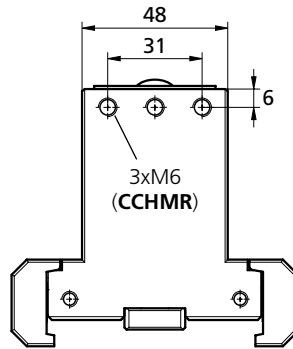
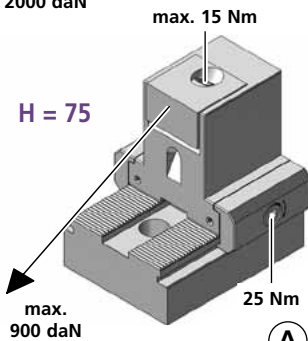
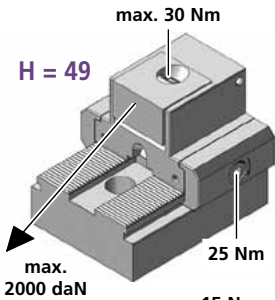
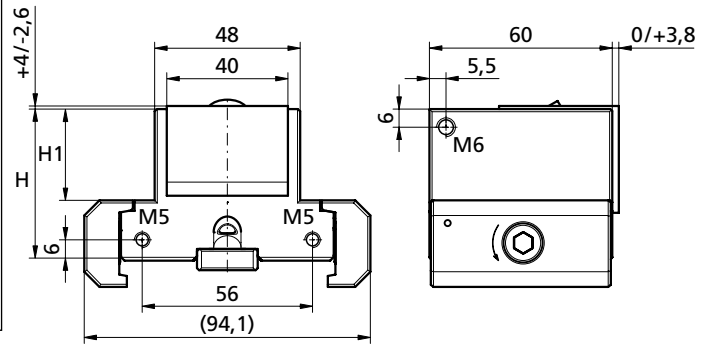
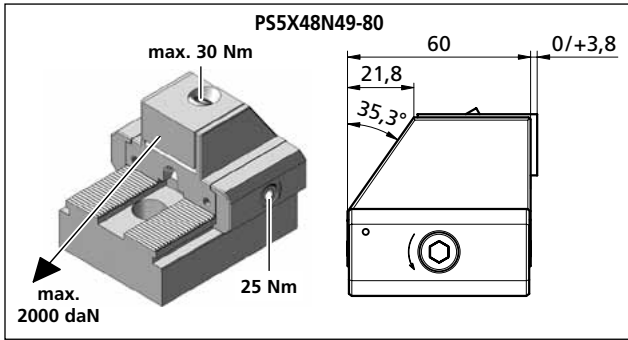

<b>PS5X48N49-80</b>
1x TF140469
2x PCD005
2x M5X14ISO4762
kg ~1,3
<b>PS1F48N49-80</b>
1x TF140467
<b>PS1R48N49-80</b>
1x TF140468
1x [Component 2]
1x PCSP60R
1x PCSP60L
1x PCS14
1x PCGU2049
1x M6X8ISO7380
2x M5X14ISO4762
2x PCD005
1x M10X25ISO4762
2x FED0618
2x M5X10ISO4762
H = 49
H1 = 30
kg ~1,4

<b>PS1R48N75-80</b>
1x TF140471
H = 75
H1 = 56
kg ~2,0

Bestellbeispiel / Ordering example: 1x PS1F48N49-80 & 1x B80

	B80	B80N	B81	B82	B82L33	B82HM	B83	B84	B89F	B89R
C	40	40	40	40	40	40	40	40	40	40
H	25	25	25	25	25	25	25	25	25	25
L	22	22	22	22,2	33	22,2	22	26,3	29	29
D	11	11	11	11	11	11	11	11	11	11
ø	15	15	15	15	15	15	15	15	15	15
i	56HRC	HV700 x0,2mm	56HRC	*	*	56HRC	HV700 x0,2mm	*	HV700 x0,2mm	HV700 x0,2mm
kg	~0,2	~0,2	~0,2	~0,2	~0,28	~0,2	~0,2	~0,2	~0,24	~0,24

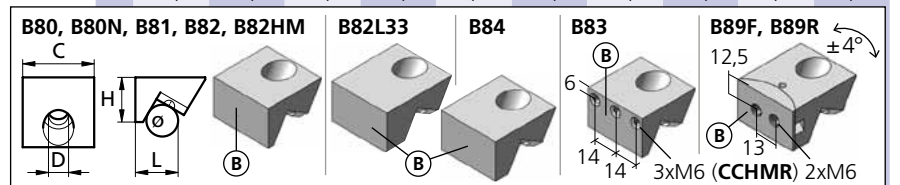

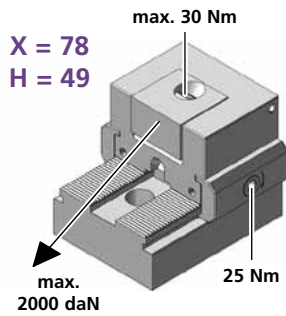
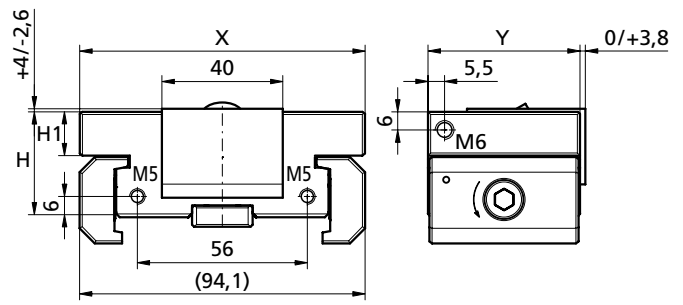
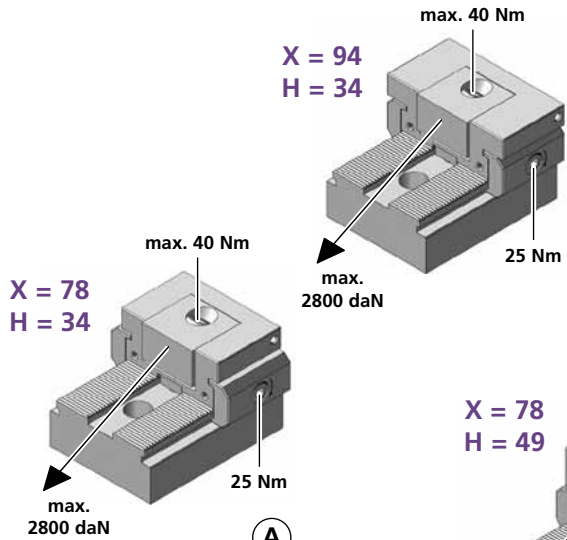

**PS1F78N34-80**

- 1 1x TF140472

**PS1R78N34-80**

- 1 1x TF140473
- 2 1x
- 3 1x PCSP50R
- 4 1x PCSP50L
- 5 1x PCS14
- 6 1x PCGU2049
- 7 1x M6X8ISO7380
- 8 2x M5X14ISO4762
- 9 2x PCD005
- 10 1x M10X25ISO4762
- 11 2x FED0618
- 12 2x M5X10ISO4762

X = 48  
H = 34  
H1 = 15  
Y = 50  
kg ~1,1

**PS1F94N34-80**

- 1 1x TF140476

**PS1R94N34-80**

- 1 1x TF140477

X = 94  
H = 34  
H1 = 15  
Y = 50  
kg ~1,1

**PS1F78N49-80**

- 1 1x TF140474

**PS1R78N49-80**

- 1 1x TF140475
- 3 1x PCSP60R
- 4 1x PCSP60L

X = 78  
H = 49  
H1 = 30  
Y = 60  
kg ~1,8

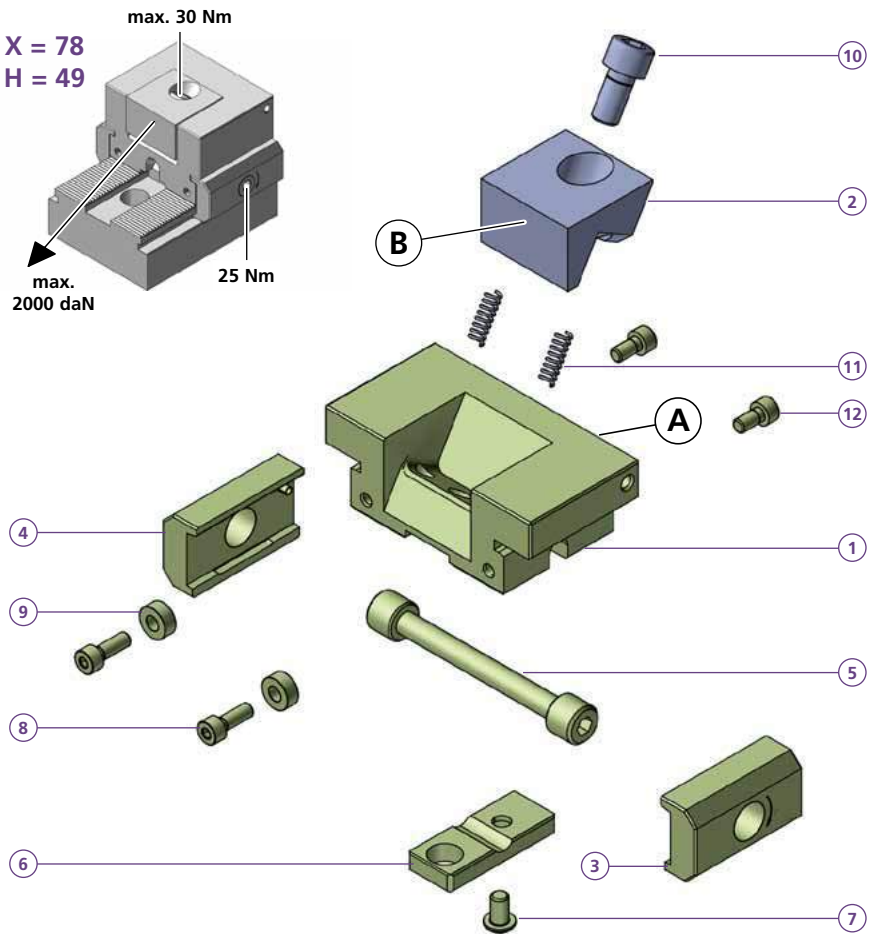

Bestellbeispiel / Ordering example: 1x PS1R94N34-80 & 1x B80

	B80	B80N	B81	B82	B82L33	B82HM	B83	B84	B89F	B89R
C	40	40	40	40	40	40	40	40	40	40
H	25	25	25	25	25	25	25	25	25	25
L	22	22	22	22,2	33	22,2	22	26,3	29	29
D	11	11	11	11	11	11	11	11	11	11
ø	15	15	15	15	15	15	15	15	15	15
i	56HRC	HV700 x0,2mm	56HRC	*	*	56HRC	HV700 x0,2mm	*	HV700 x0,2mm	HV700 x0,2mm
kg	~0,2	~0,2	~0,2	~0,2	~0,28	~0,2	~0,2	~0,2	~0,24	~0,24

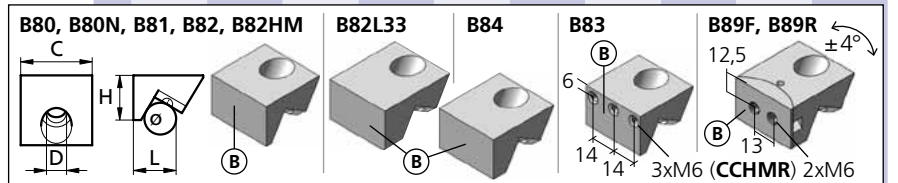

\* = weicher Stahl / soft steel

HM = Hartmetallbeschichtet / Carbide coated



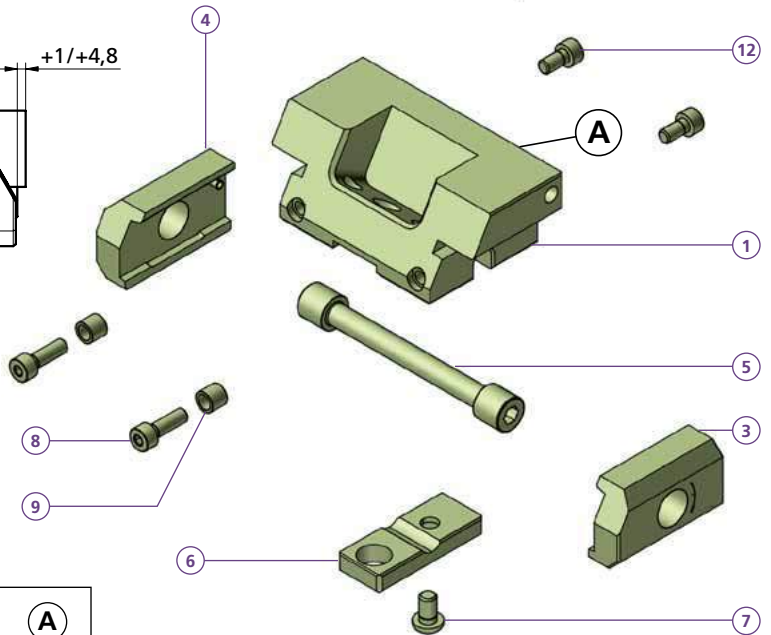
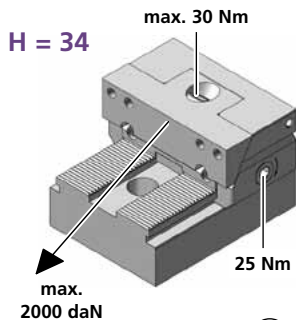
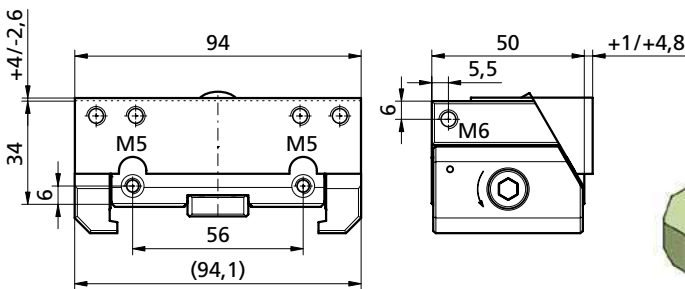
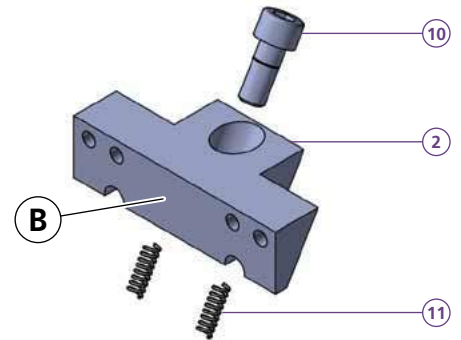
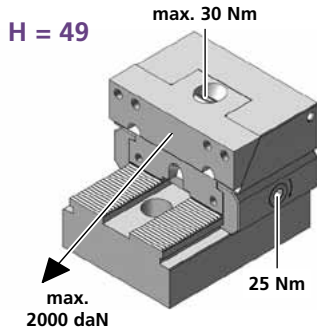
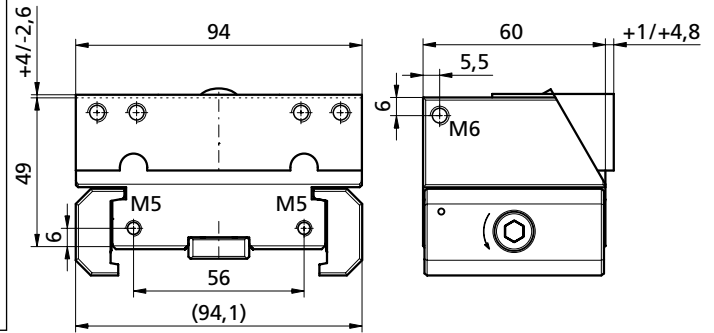
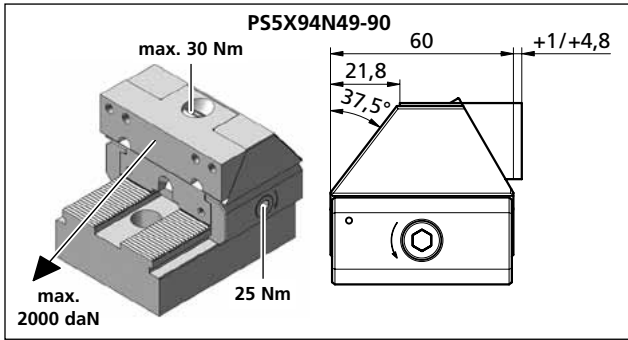

PS1F94N34-90		PS5X94N49-90	
1	1x TF140478	1	1x TF140482
2	1x _____	3	1x PCSP60R
3	1x PCSP50RF	4	1x PCSP60L
4	1x PCSP50LF	9	2x PCD005
5	1x PCS14	8	2x M5X14ISO4762
6	1x PCGU2049	kg	~1,8
7	1x M6X8ISO7380	<b>PS1F94N49-90</b>	
8	2x M5X16ISO4762	1	1x TF140480
9	2x PCD008	2	1x _____
10	1x M10X25ISO4762	<b>PS1R94N49-90</b>	
11	2x FED0618	1	1x TF140481
12	2x M5X10ISO4762	3	1x PCSP60R
H = 34		4	1x PCSP60L
kg ~1,0		8	2x M5X14ISO4762
		9	2x PCD005
		H = 49	
		kg ~2,0	

Bestellbeispiel / Ordering example:  
1x PS1F94N34-90 & 1x B91

	B90	B91	B92	B93	B94
C	94	94	94	94	94
H	25	25	25	25	25
L	23	23	23	23	40
D	11	11	11	11	11
e	15	15	15	15	15
i	HV700 x0,2mm	HV700 x0,2mm	*	HV700 x0,2mm	*
kg	~0,33	~0,33	~0,33	~0,33	~0,64

B94

B

4xM6 (CCHMR)

Separat bestellen / Separate order

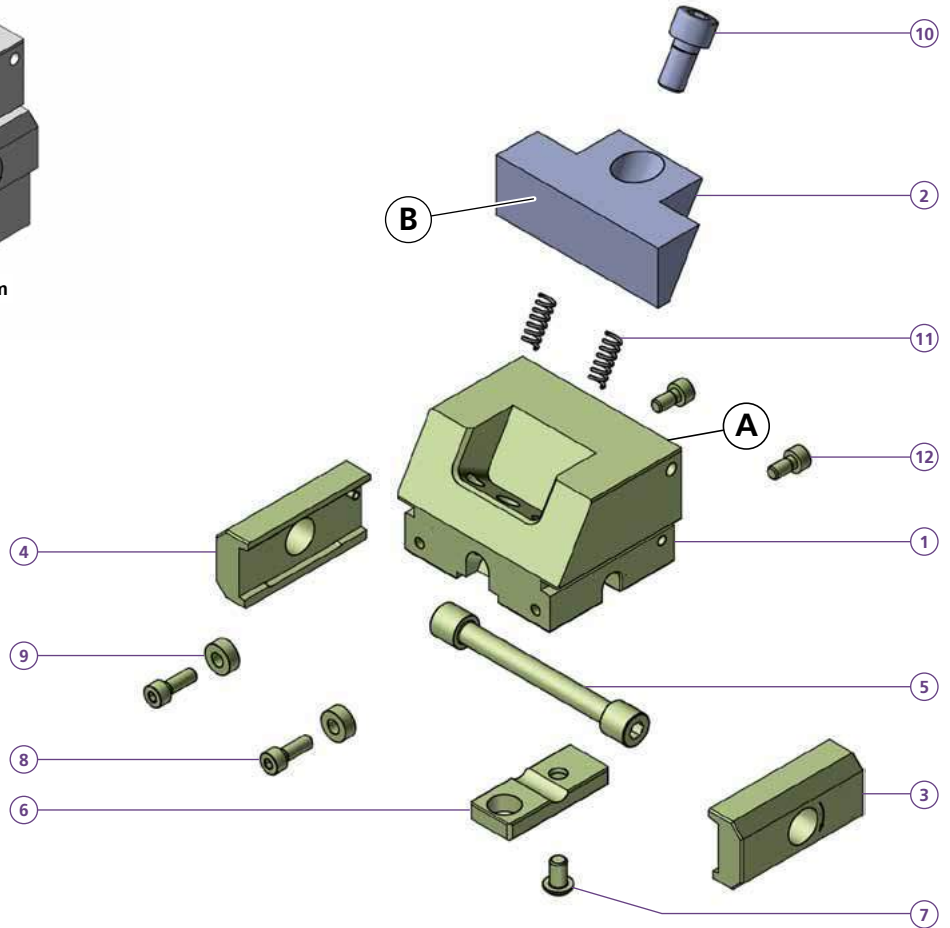
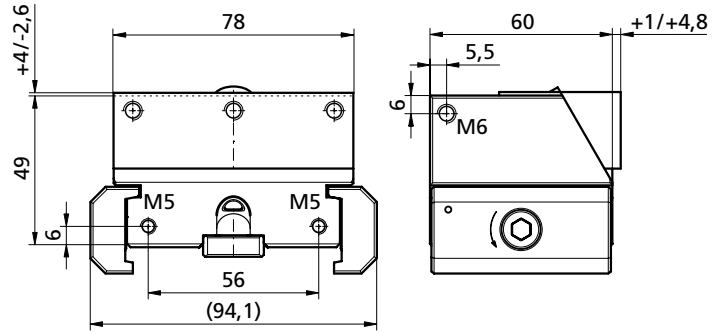
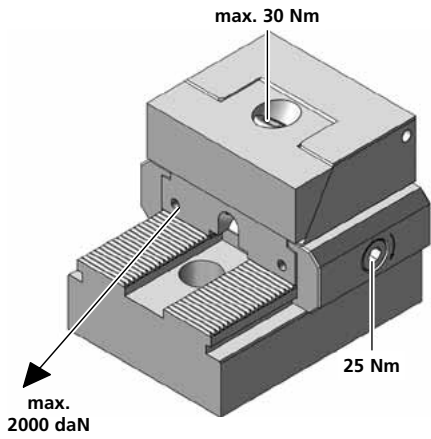

<b>PS1F78N49-90</b>	
1	1x TH160490
<b>PS1R78N49-90</b>	
1	1x TH160490
2	1x
3	1x PCSP60R
4	1x PCSP60L
5	1x PCS14
6	1x PCGU2049
7	1x M6X8ISO7380
8	2x M5X14ISO4762
9	2x PCD005
10	1x M10X25ISO4762
11	2x FED0618
12	2x M5X10ISO4762
kg	~1,8

Bestellbeispiel / Ordering example:  
1x PS1F78N49-90 & 1x B90F78

	B90F78	B90W78	B90R78
C	78	78	78
H	25	25	25
L	23	28	23
D	11	11	11
e	15	15	15
i	HV700	*	HV700
	x0,2mm		x0,2mm
kg	~0,3	~0,37	~0,3

**B90R78**

78  
27 27  
6  
3xM6 (CCHMR)

**B90F78, B90W78**

\* = weicher Stahl / soft steel



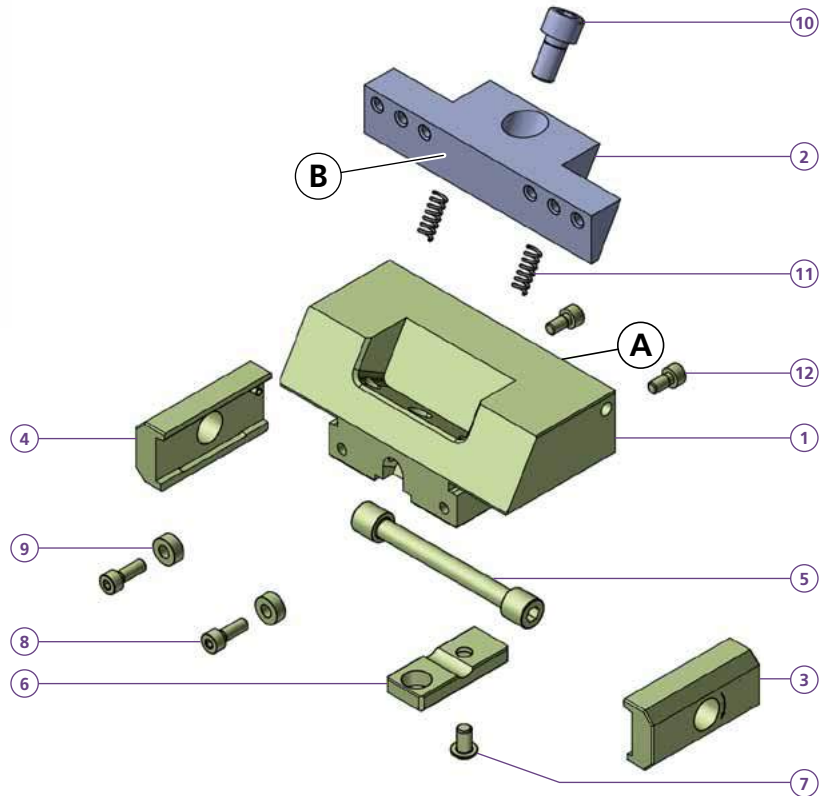
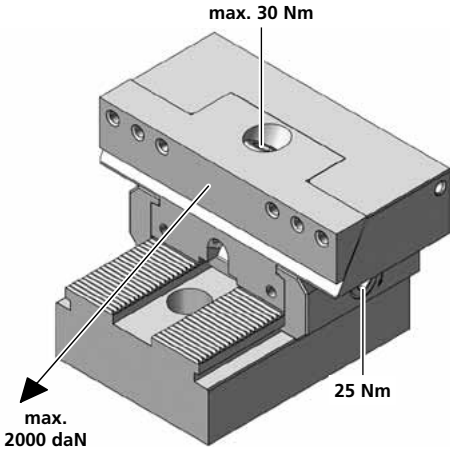
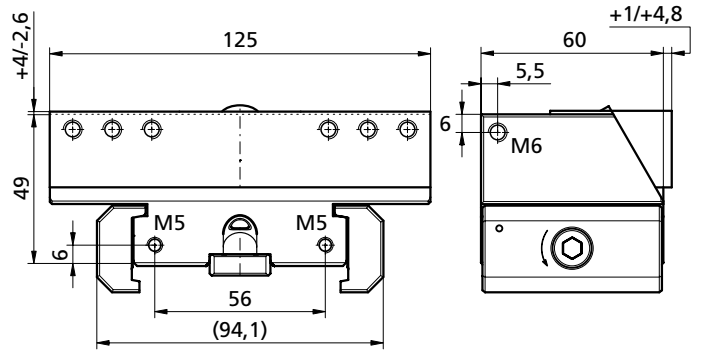
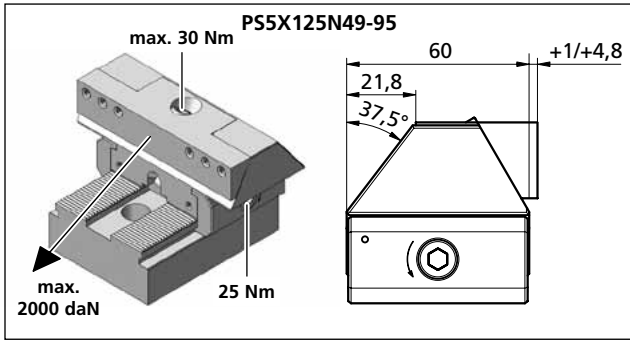

<b>37,5°</b>	<b>PS5X125N49-95</b>
1	1x TF140485
9	2x PCD005
8	2x M5X14ISO4762
kg	~2,0
	<b>PS1F125N49-95</b>
1	1x TF140483
	<b>PS1R125N49-95</b>
1	1x TF140484
2	1x
3	1x PCSP60R
4	1x PCSP60L
5	1x PCS14
6	1x PCGU2049
7	1x M6X8ISO7380
8	2x M5X14ISO4762
9	2x PCD005
10	1x M10X25ISO4762
11	2x FED0618
12	2x M5X10ISO4762
kg	~2,3

Bestellbeispiel / Ordering example: 1x PS5X125N49-95 & 1x B95

	B95	B96	B97	B98	B99
C	125	125	125	125	125
H	25	25	25	25	25
L	23	23	23	30	23
D	11	11	11	11	11
ø	15	15	15	15	15
i	HV700	HV700	*	*	HV700
	x0,2mm	x0,2mm			x0,2mm
kg	~0,46	~0,45	~0,46	~0,63	~0,45

B95, B96, B97, B99		B98	
6xM6 (CCHMR)		110	
		84	
		58	
		6	

  

Separat bestellen / Separate order



# PS2G94N44-13

powerCLAMP

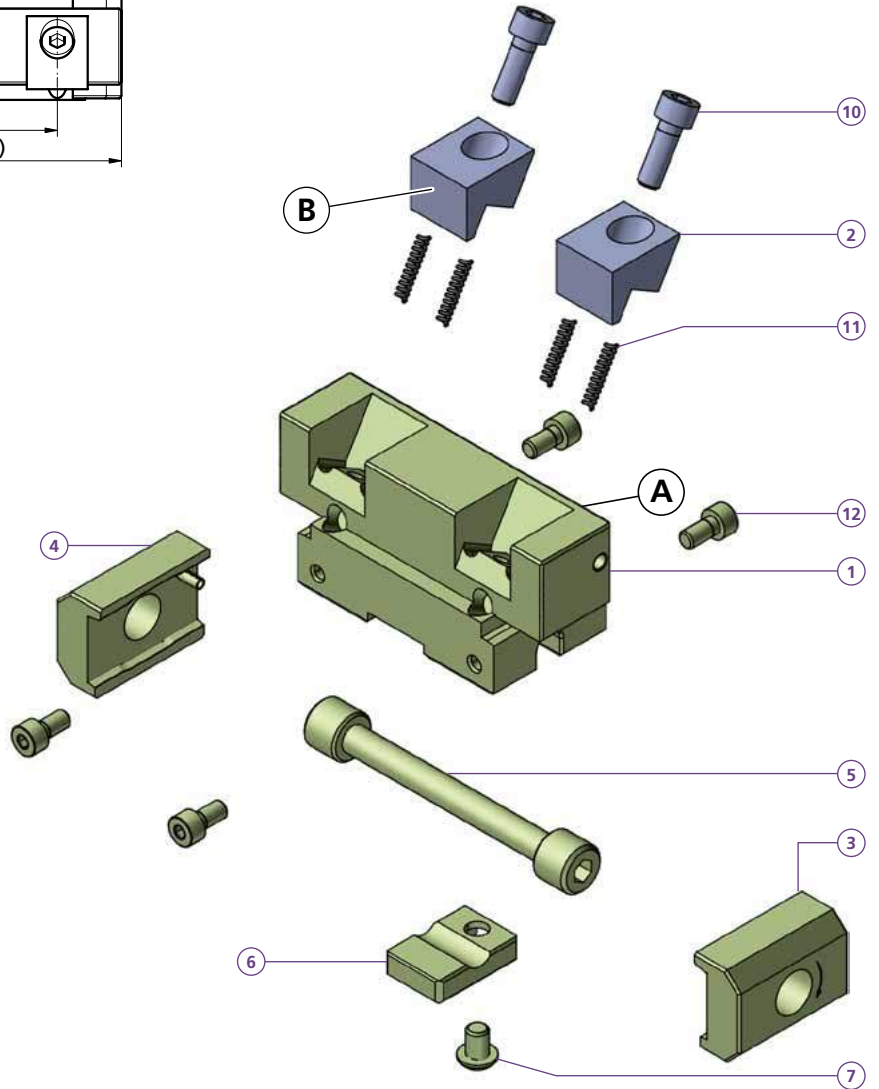
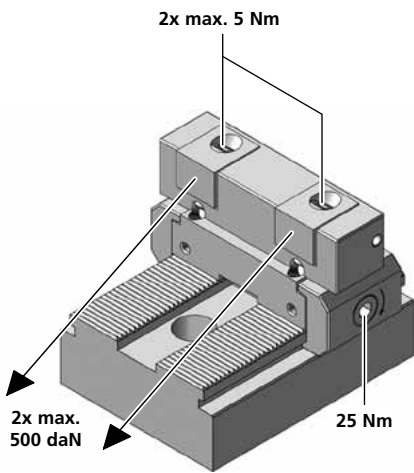
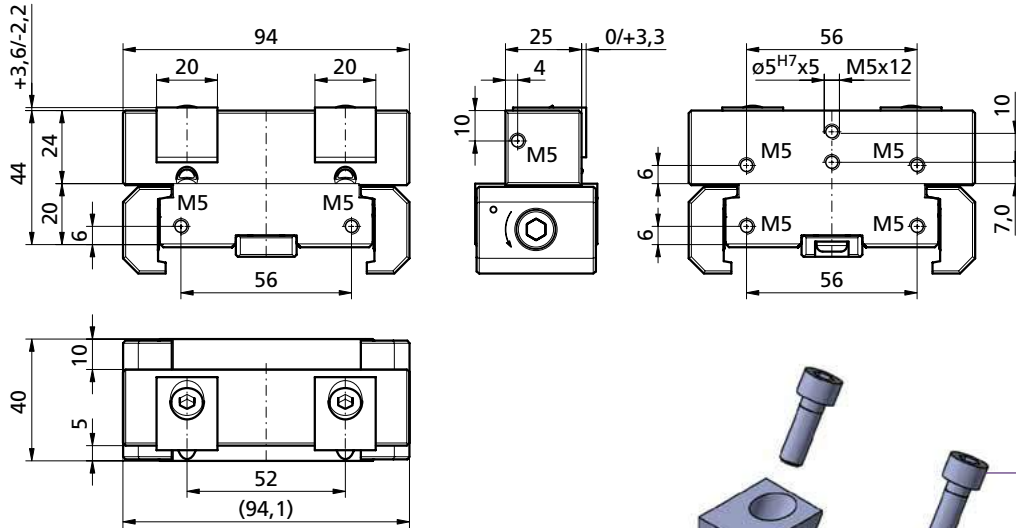

PS2G94N44-13	
1	1x TF140486
2	2x
3	1x PCSP40R
4	1x PCSP40L
5	1x PCS14
6	1x PCGU2030
7	1x M6X8ISO7380
10	2x M6X16ISO4762
11	4x FED0318
12	4x M5X10ISO4762
kg	~1,0

	B13	B14	B15	B16
C	20	20	20	20
H	16	16	16	16
L	13,8	13,8	13,8	19
D	6,5	6,5	6,5	6,5
ø	10	10	10	10
i	HV700	HV700	*	*
	x0,2mm	x0,2mm		
kg	~0,05	~0,05	~0,05	~0,06

Bestellbeispiel / Ordering example: 1x PS2G94N44-13 & 2x B14

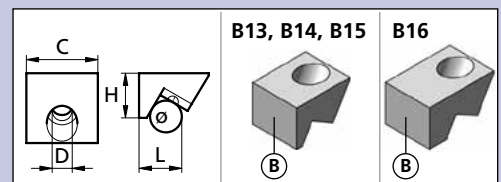

\* = weicher Stahl / soft steel

Separat bestellen / Separate order

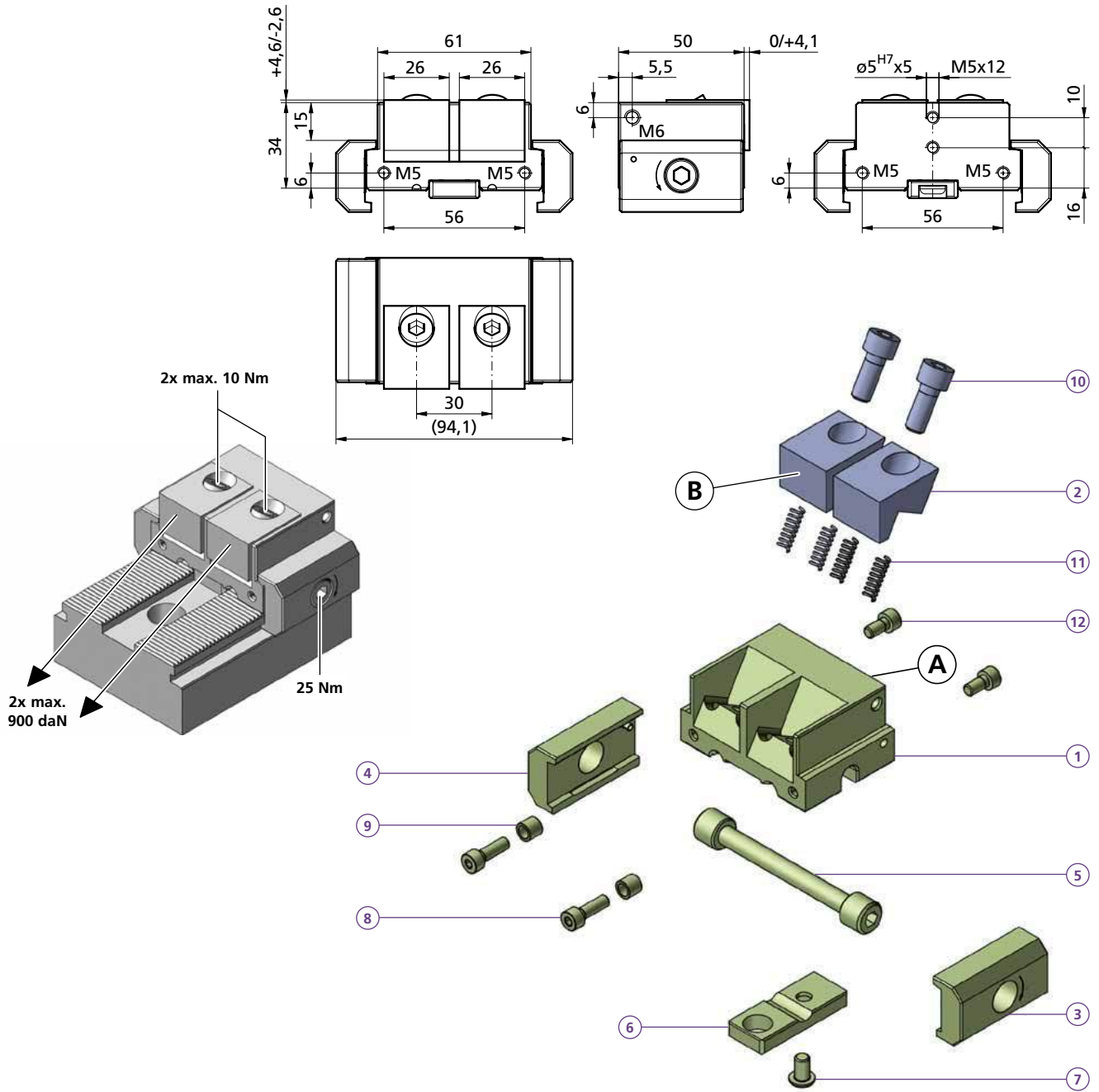

	<b>PS2F61N34-45</b>
①	1x TF140487
	<b>PS2R61N34-45</b>
①	1x TF140488
②	2x
③	1x PCSP50R
④	1x PCSP50L
⑤	1x PCS14
⑥	1x PCGU2049
⑦	1x M6X8ISO7380
⑧	2x M5X16ISO4762
⑨	2x PCD008
⑩	2x M8X20ISO4762
⑪	4x FED0618
⑫	2x M5X10ISO4762
kg	~1,0

**Bestellbeispiel / Ordering example: 1x PS2R61N34-45 & 2x B47HM**

	B45	B46	B47	B47HM
③	26	26	26	26
④	20	20	20	20
⑤	19	19	19,1	19,1
⑥	9	9	9	9
⑦	12	12	12	12
⑧	HV700	HV700	*	HM
	x0,2mm	x0,2mm		
kg	~0,1	~0,1	~0,1	~0,1



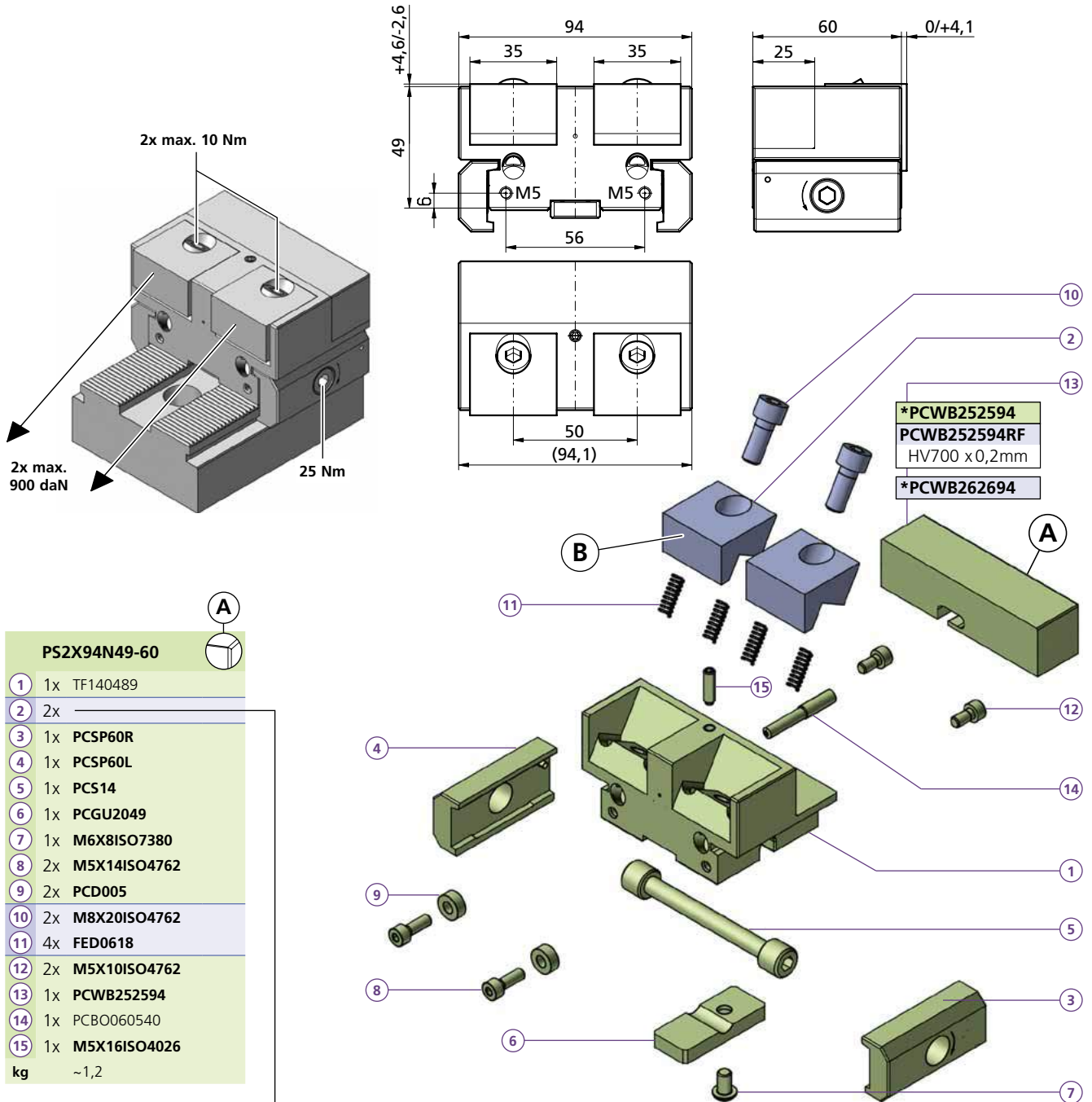

- PS2X94N49-60**
- 1 1x TF140489
  - 2 2x
  - 3 1x PCSP60R
  - 4 1x PCSP60L
  - 5 1x PCS14
  - 6 1x PCGU2049
  - 7 1x M6X8ISO7380
  - 8 2x M5X14ISO4762
  - 9 2x PCD005
  - 10 2x M8X20ISO4762
  - 11 4x FED0618
  - 12 2x M5X10ISO4762
  - 13 1x PCWB252594
  - 14 1x PCBO060540
  - 15 1x M5X16ISO4026
- kg ~1,2

**Bestellbeispiel / Ordering example:** 1x PS2X94N49-60 & 2x B58

	B58	B60	B61	B62	B62HM	B65	B66	B67	B68	B69	B77	B79F	B79R
C	35	35	35	35	35	35	35	35	35	35	35	35	35
H	20	20	20	20	20	20	20	20	20	25	20	20	20
L	26	19	19	19	19	19	19	24	26	22	22	25	25
D	9	9	9	9	9	9	9	9	9	9	9	9	9
o	12	12	12	12	12	12	12	12	12	12	12	12	12
i	ALU	56HRC	56HRC	*	HM	HV700 x0,2mm	HV700 x0,2mm	HV700 x0,2mm	*	*	56HRC	HV700 x0,2mm	HV700 x0,2mm
kg	~0,07	~0,12	~0,12	~0,12	~0,12	~0,12	~0,12	~0,14	~0,15	~0,15	~0,12	~0,18	~0,18

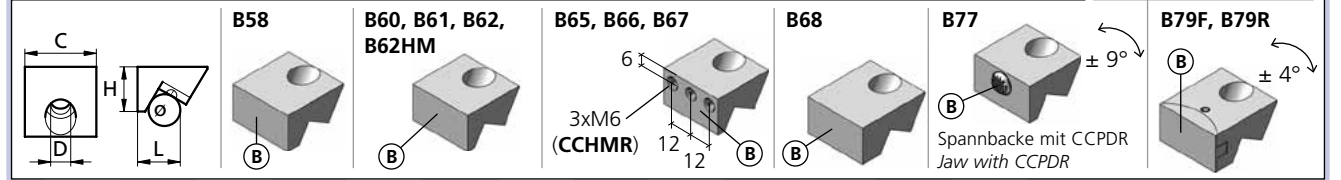
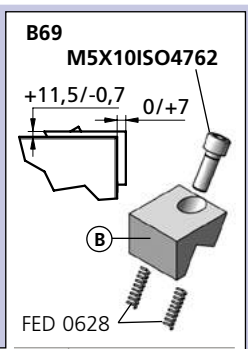

\* = weicher Stahl / soft steel      HM = Hartmetallbeschichtet / Carbide coated      ALU = ENAW-7022

Separat bestellen / Separate order

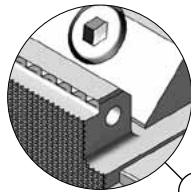
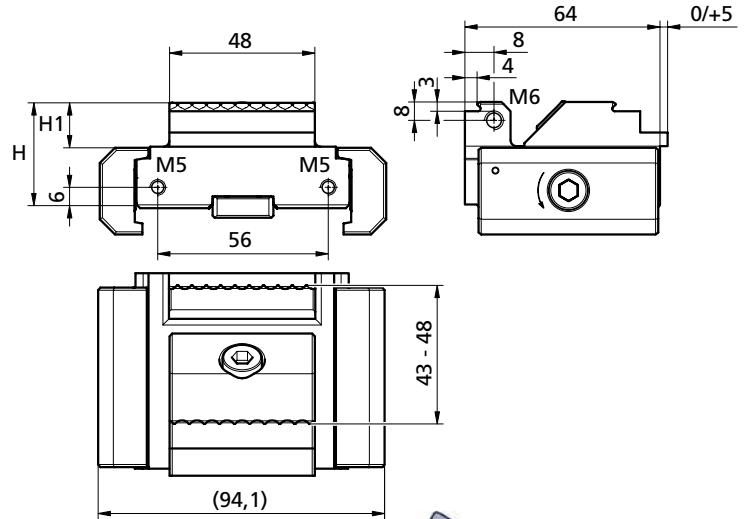
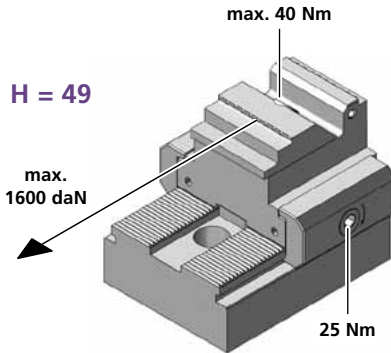
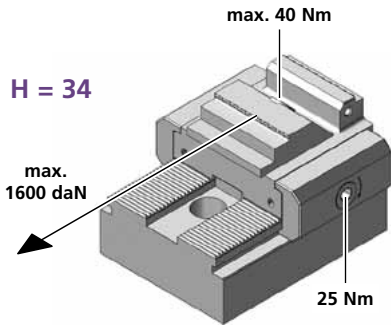

PS1P48L34-105

- 1 1x TW100098-01
  - 2 1x \_\_\_\_\_
  - 3 1x PCSP60R
  - 4 1x PCSP60L
  - 5 1x PCS14
  - 6 1x PCGU2059
  - 7 1x M6X8ISO7380
  - 8 2x M5X14ISO4762
  - 9 2x PCD005
  - 10 1x M8X28ISO4762
  - 11 1x PCUSR16
  - 12 2x M5X10ISO4762
  - 13 1x PCKMR45M8
  - 14 2x BN869d=6
- H = 34  
H1 = 15  
kg ~1,0

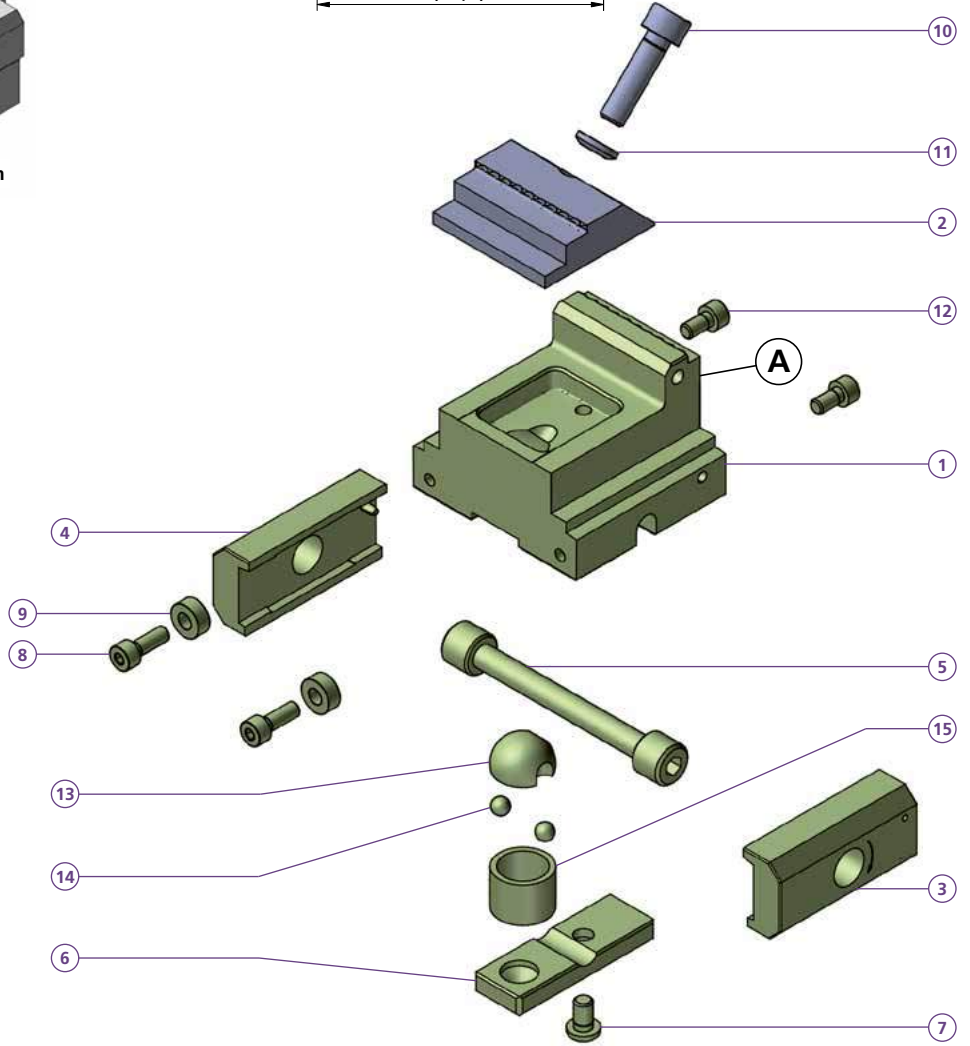

p. 84

PS1PF48L34-105

- 1 1x TK140780
- H = 49  
H1 = 30  
kg ~1,0

PS1P48L49-105

- 1 1x TK120011
  - 15 1x PCD20L15
- H = 49  
H1 = 30  
kg ~1,4

PS1PF48L49-105

- 1 1x TK140781
  - 15 1x PCD20L15
- H = 49  
H1 = 30  
kg ~1,4

Bestellbeispiel / Ordering example:  
1x PS1P48L34-105 & 1x B115

Drehmoment Torque		Spannkraft Workholding force		
Nm	(lb-ft)	~daN	~(lb)	~t
10	7,4	= 400	880	0,4
20	14,8	= 800	1'760	0,8
30	22,2	= 1'200	2'650	1,2
40	29,6	= 1'600	3'530	1,6

PS1P94L34-105  
 PS1P694L34-105  
 PS1P94L49-105

PS1PF94L49-105  
 PS1PF94L34-105

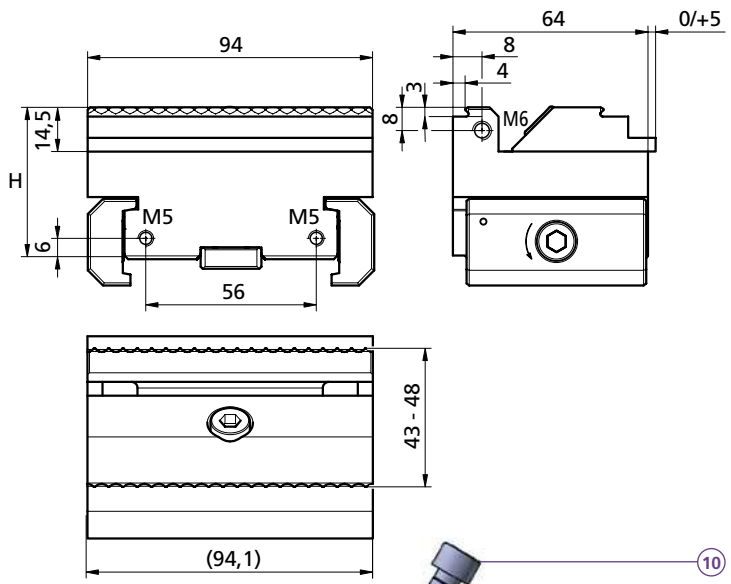
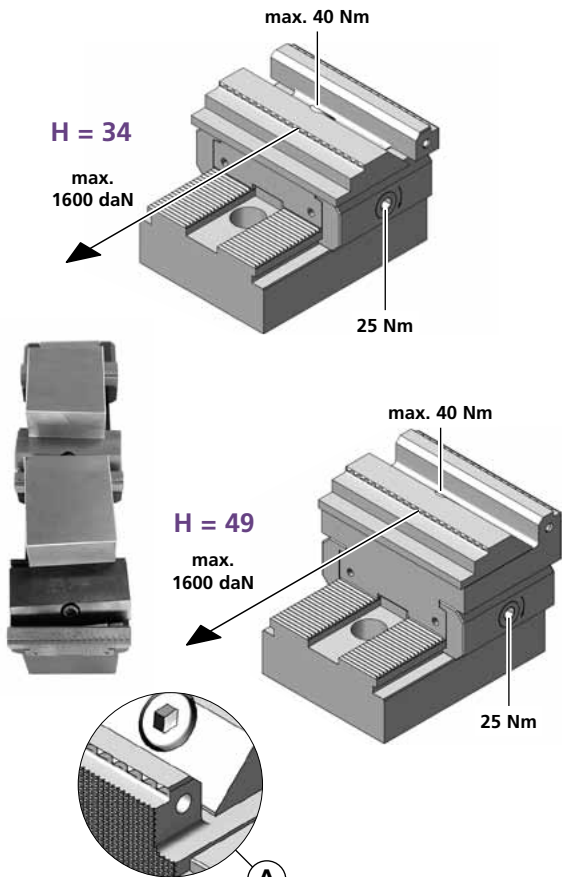

- PS1P94L34-105**
- 1 1x TW100100-01
  - 2 1x
  - 3 1x PCSP60R
  - 4 1x PCSP60L
  - 5 1x PCS14
  - 6 1x PCGU2059
  - 7 1x M6X8ISO7380
  - 8 2x M5X14ISO4762
  - 9 2x PCD005
  - 10 1x M8X28ISO4762
  - 11 1x PCUSR16
  - 12 2x M5X10ISO4762
  - 13 1x PCKMR45M8
  - 14 2x BN869d=6
- H = 34  
 kg ~1,1

- PS1P694L34-105**
- 1 1x TW100100-02
  - Y 6,0 mm
- kg ~1,1

- PS1PF94L34-105**
- 1 1x TK140782
- H = 49  
 kg ~1,1

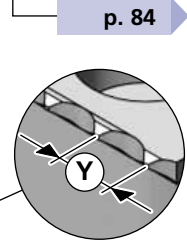

- PS1P94L49-105**
- 1 1x TK120857
  - 15 1x PCD20L15
- H = 49  
 kg ~1,8

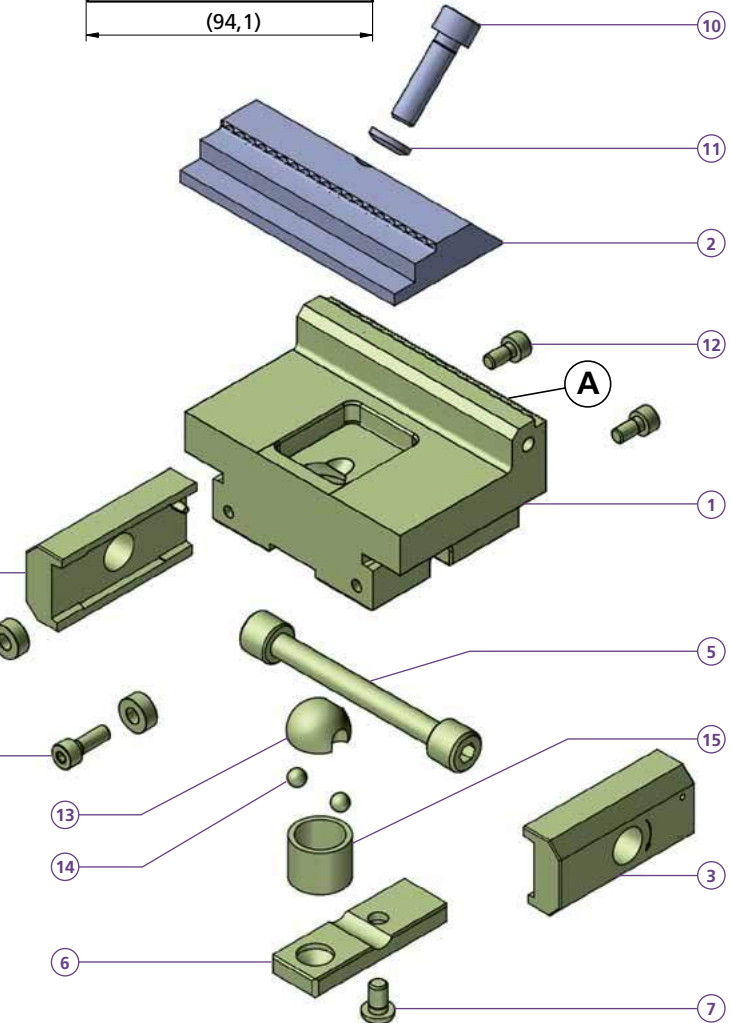

p. 84

- PS1PF94L49-105**
- 1 1x TK140783
  - 15 1x PCD20L15
- H = 49  
 kg ~1,8

Bestellbeispiel / Ordering example:  
 1x PS1P94L34-105 & 1x B120

Drehmoment Torque		Spannkraft Workholding force		
Nm	(lb-ft)	~daN	~(lb)	~t
10	7,4	= 400	880	0,4
20	14,8	= 800	1'760	0,8
30	22,2	= 1'200	2'650	1,2
40	29,6	= 1'600	3'530	1,6

Separat bestellen / Separate order



PS1PV48L34-105  
PS1R/F48L34-105

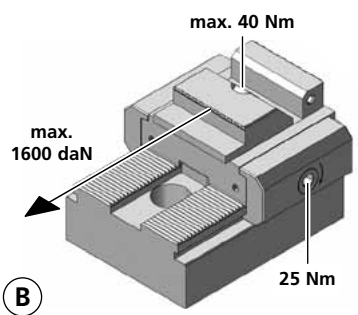
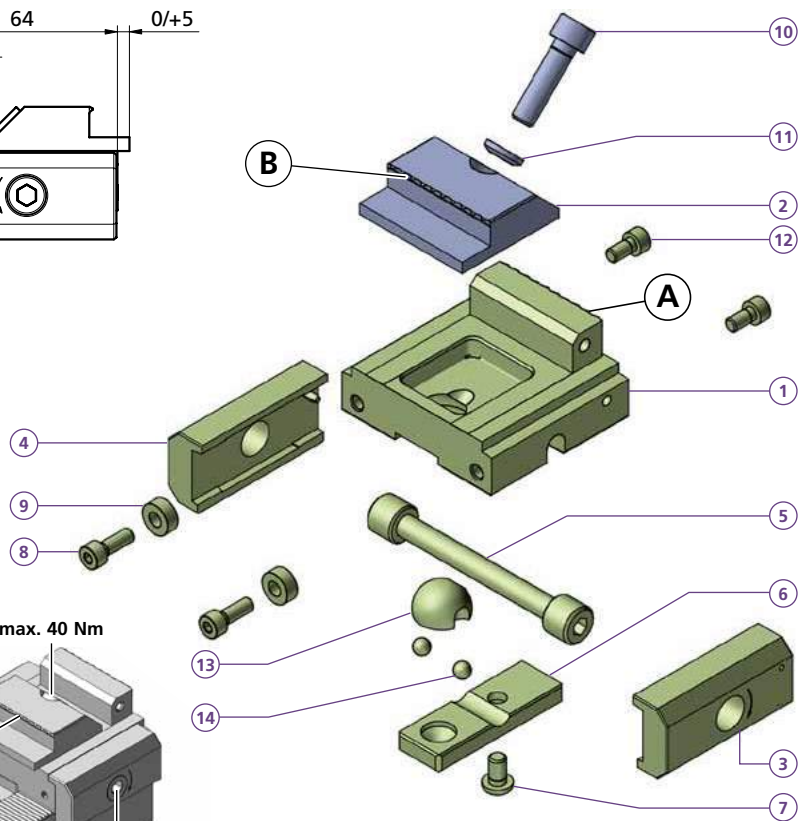
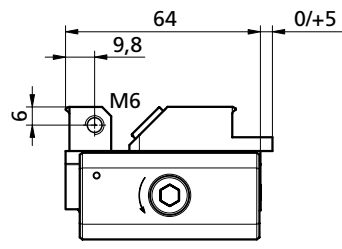
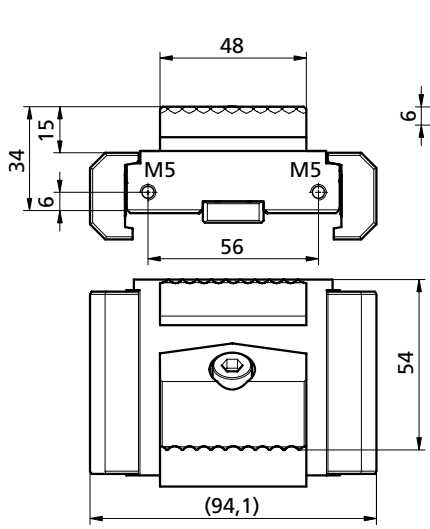

**PS1PV48L34-105**

1	1x	TK140762
2	1x	
3	1x	PCSP60R
4	1x	PCSP60L
5	1x	PCS14
6	1x	PCGU2059
7	1x	M6X8ISO7380
8	2x	M5X14ISO4762
9	2x	PCD005
10	1x	M8X28ISO4762
11	1x	PCUSR16
12	2x	M5X10ISO4762
13	1x	PCKMR45M8
14	2x	BN869d=6
kg		~1,0

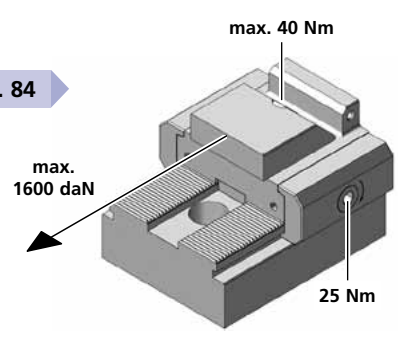
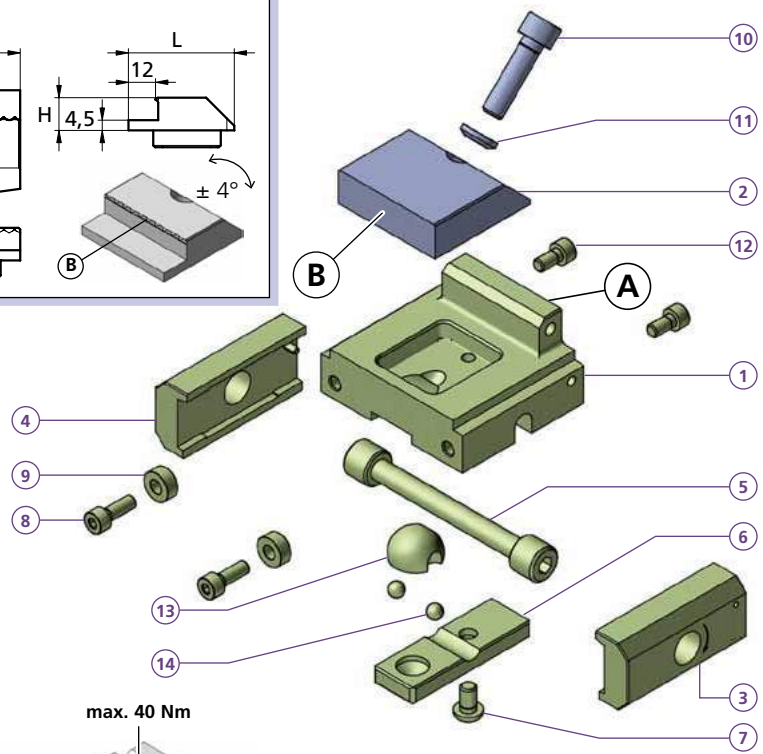
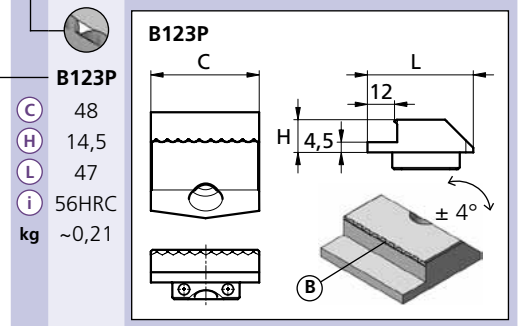

**PS1R48L34-105**

**PS1F48L34-105**

1	1x	TF140573
2	1x	
3	1x	PCSP60R
4	1x	PCSP60L
5	1x	PCS14
6	1x	PCGU2059
7	1x	M6X8ISO7380
8	2x	M5X14ISO4762
9	2x	PCD005
10	1x	M8X30ISO4762
11	1x	PCUSR14
12	2x	M5X10ISO4762
13	1x	PCKMR45M8
14	2x	BN869d=6
kg		~1,0

p. 84

Bestellbeispiel / Ordering example:  
1x PS1R48L34-105 & 1x B123P

Drehmoment Torque		Spannkraft Workholding force		
Nm	(lb-ft)	~daN	~(lb)	~t
10	7,4	= 400	880	0,4
20	14,8	= 800	1'760	0,8
30	22,2	= 1'200	2'650	1,2
40	29,6	= 1'600	3'530	1,6

Separat bestellen / Separate order

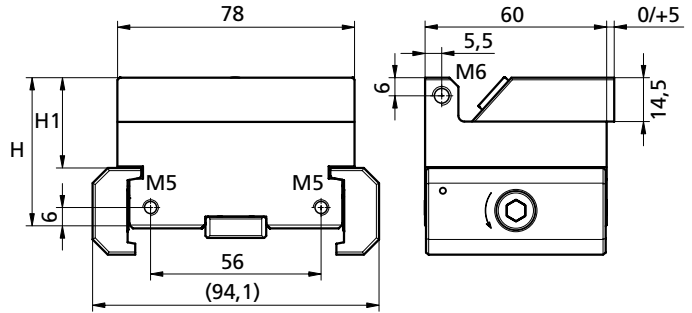
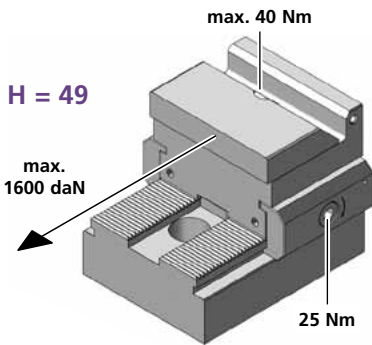
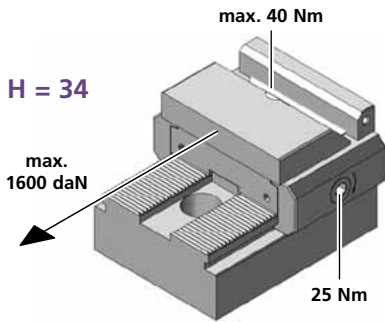

- PS1R78L34-105**
- 1 1x TF140575
- PS1F78L34-105**
- 1 1x TF140574
  - 2 1x
  - 3 1x PCSP60R
  - 4 1x PCSP60L
  - 5 1x PCS14
  - 6 1x PCGU2059
  - 7 1x M6X8ISO7380
  - 8 2x M5X14ISO4762
  - 9 2x PCD005
  - 10 1x M8X30ISO4762
  - 11 1x PCUSR14
  - 12 2x M5X10ISO4762
  - 13 1x PCKMR45M8
  - 14 2x BN869d=6
- H = 34  
H1 = 15  
kg ~1,0

p. 84

- PS1R78L49-105**
- 1 1x TK110399
  - 15 2x PCD20L15
- PS1F78L49-105**
- 1 1x TK110400
  - 15 2x PCD20L15
- H = 49  
H1 = 30  
kg ~1,5

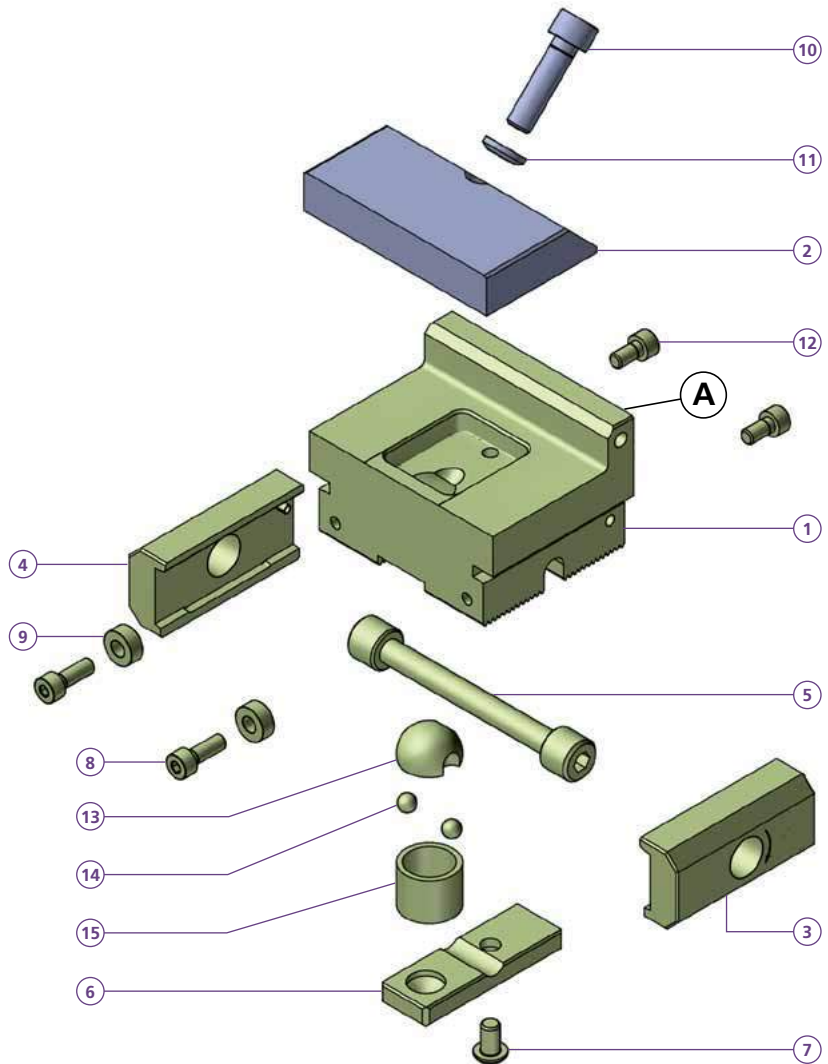

Bestellbeispiel / Ordering example:  
1x PS1R48L34-105 & 1x B105

Drehmoment Torque		Spannkraft Workholding force		
Nm	(lb-ft)	~daN	~(lb)	~t
10	7,4	= 400	880	0,4
20	14,8	= 800	1'760	0,8
30	22,2	= 1'200	2'650	1,2
40	29,6	= 1'600	3'530	1,6

Separat bestellen / Separate order

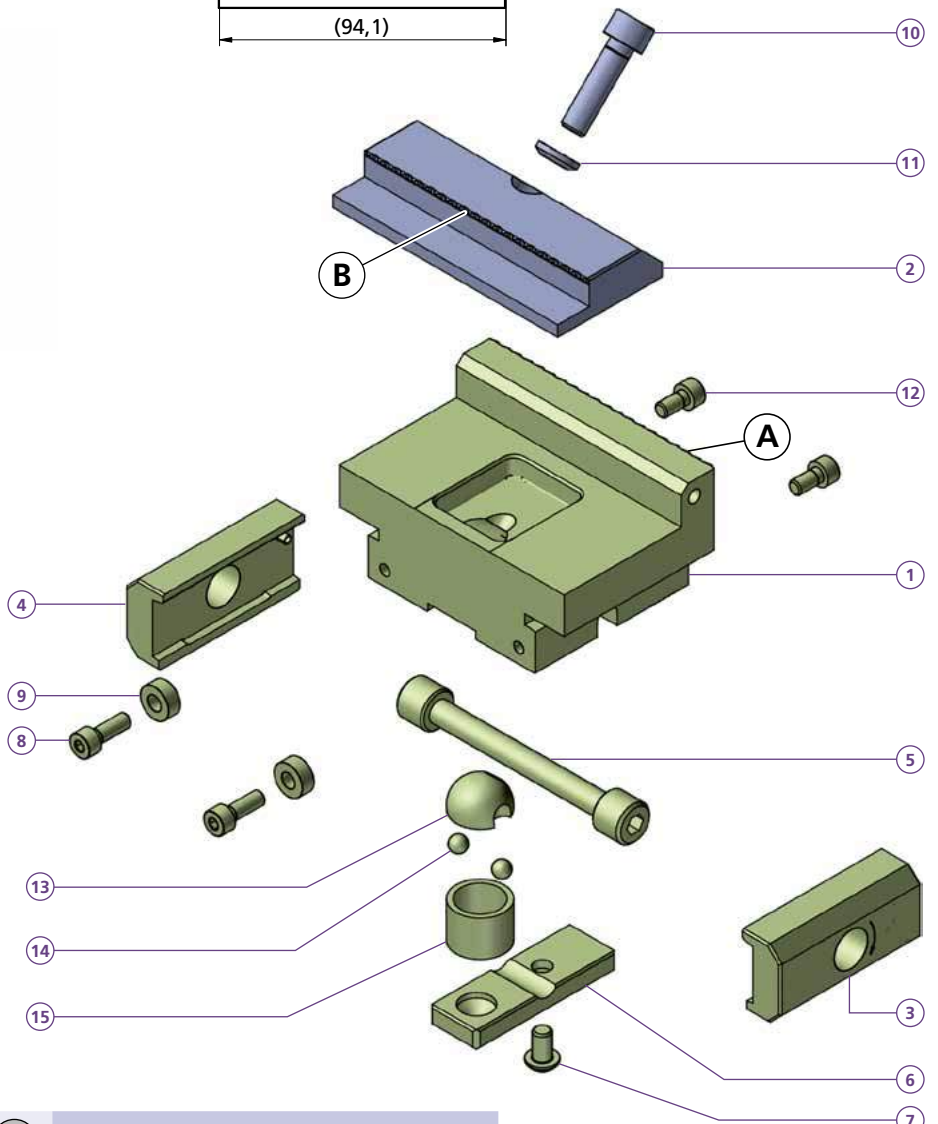
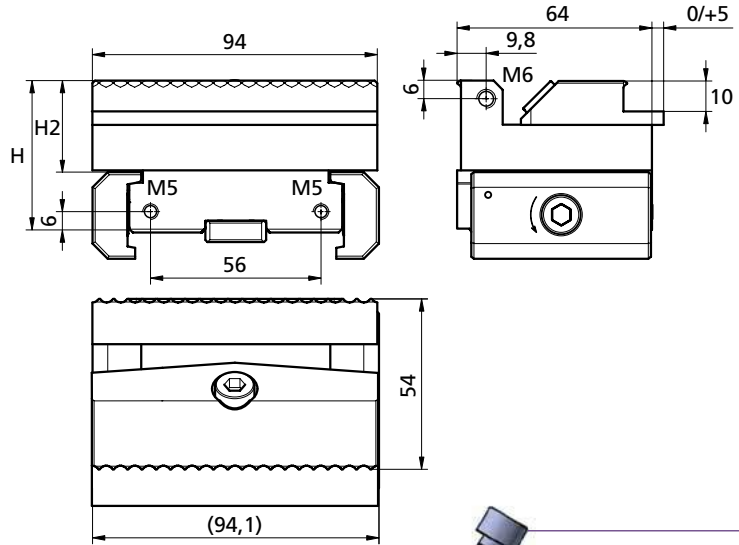
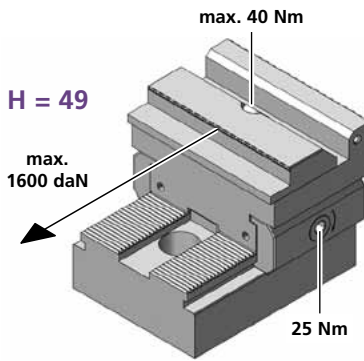
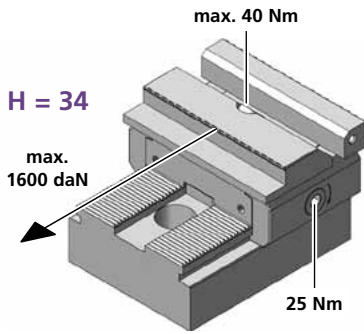

PS1PV94L34-105	
1	1x TK120230
2	1x
3	1x PCSP60R
4	1x PCSP60L
5	1x PCS14
6	1x PCGU2059
7	1x M6X8ISO7380
8	2x M5X14ISO4762
9	2x PCD005
10	1x M8X28ISO4762
11	1x PCUSR16
12	2x M5X10ISO4762
13	1x PCKMR45M8
14	2x BN869d=6
H	= 34
H1	= 15
kg	~1,1

PS1PV94L49-105	
1	1x TK110250
15	1x PCD20L15
H	= 49
H1	= 30
kg	~1,8

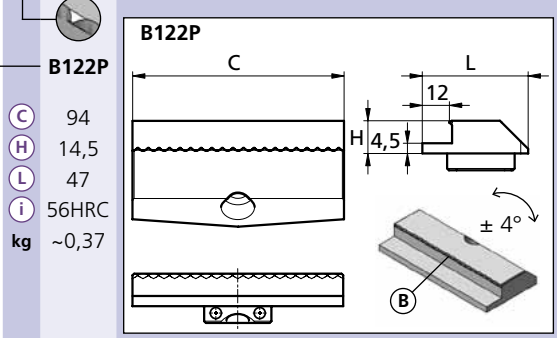

Bestellbeispiel / Ordering example:  
1x PS1PV94L49-105 & 1x B122P

Drehmoment Torque		Spannkraft Workholding force		
Nm	(lb-ft)	~daN	~(lb)	~t
10	7,4	= 400	880	0,4
20	14,8	= 800	1'760	0,8
30	22,2	= 1'200	2'650	1,2
40	29,6	= 1'600	3'530	1,6

Separat bestellen / Separate order



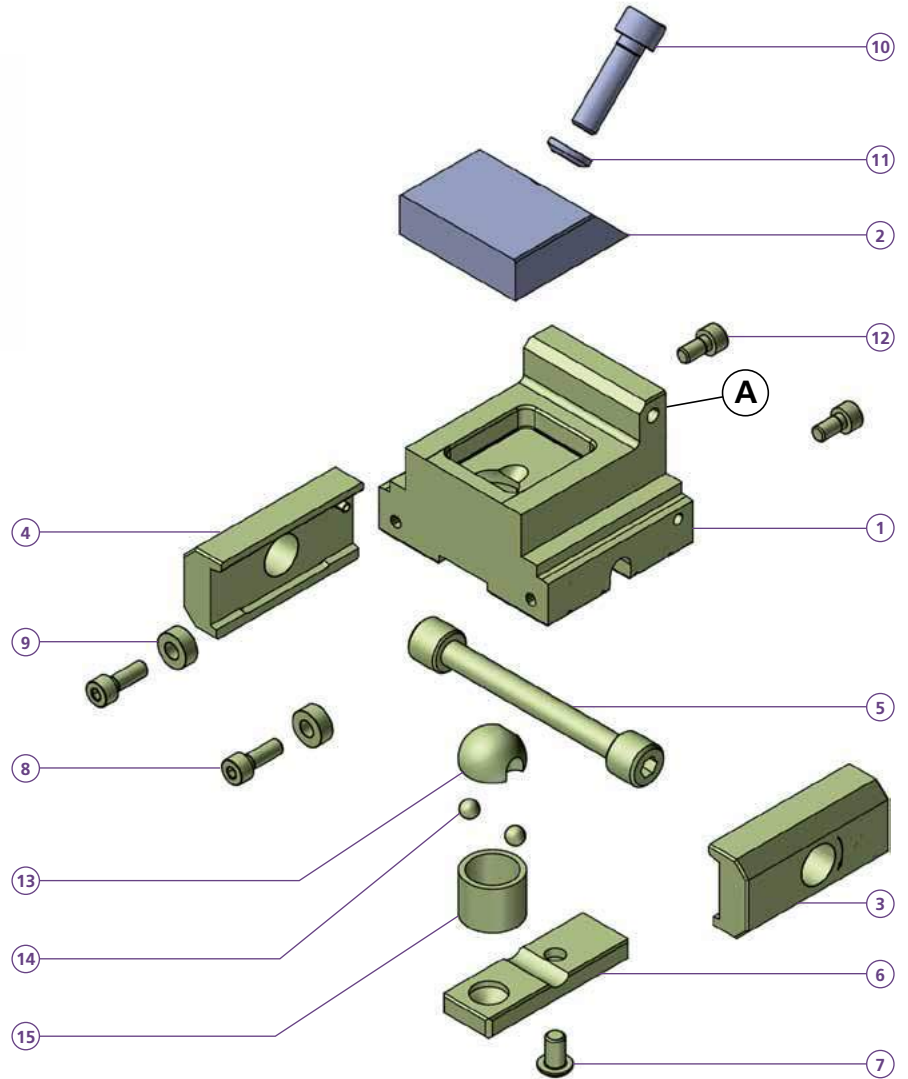
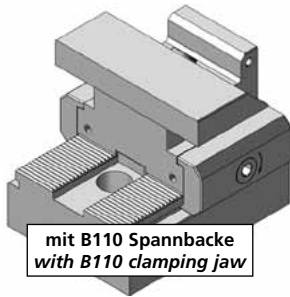
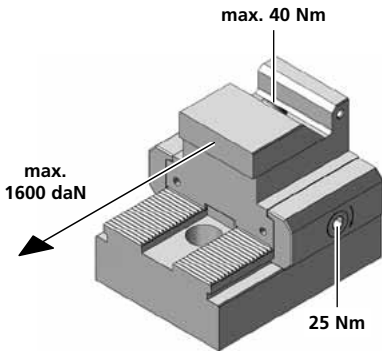
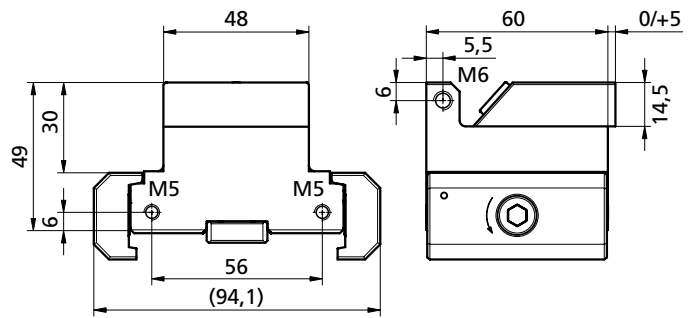
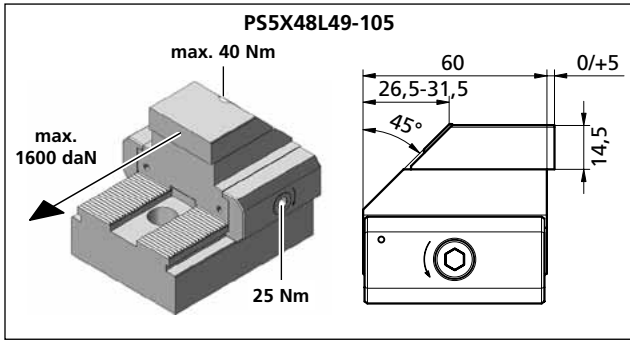

- PS5X48L49-105**
- 1 1x TF190651
  - 9 2x PCD005
  - 8 2x M5X14ISO4762
  - kg ~1,2
- PS1F48L49-105**
- 1 1x TF140673
- PS1R48L49-105**
- 1 1x TF140672
- Accessories:**
- 2 1x
  - 3 1x PCSP60R
  - 4 1x PCSP60L
  - 5 1x PCS14
  - 6 1x PCGU2059
  - 7 1x M6X8ISO7380
  - 8 2x M5X14ISO4762
  - 9 2x PCD005
  - 10 1x M8X30ISO4762
  - 11 1x PCUSR14
  - 12 2x M5X10ISO4762
  - 13 1x PCKMR45M8
  - 14 2x BN869d=6
  - 15 1x PCD20L15
  - kg ~1,3

p. 84



Bestellbeispiel / Ordering example:  
1x PS1F48L49-105 & 1x B105

Drehmoment Torque		Spannkraft Workholding force		
Nm	(lb-ft)	~daN	~(lb)	~t
10	7,4	= 400	880	0,4
20	14,8	= 800	1'760	0,8
30	22,2	= 1'200	2'650	1,2
40	29,6	= 1'600	3'530	1,6

PS5X48L34-105

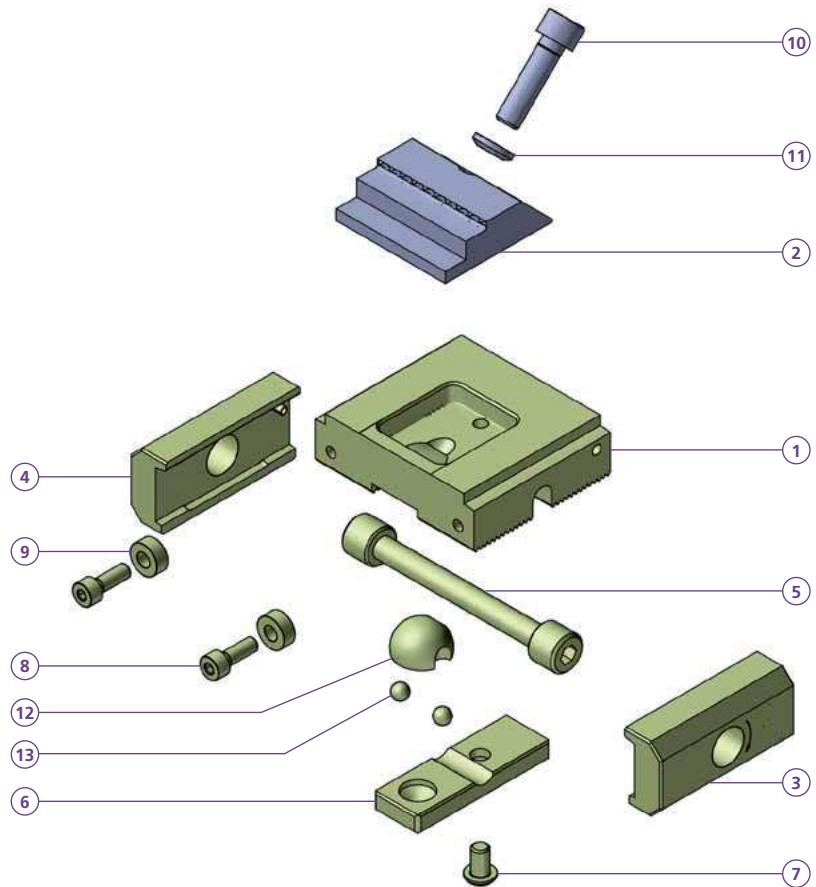
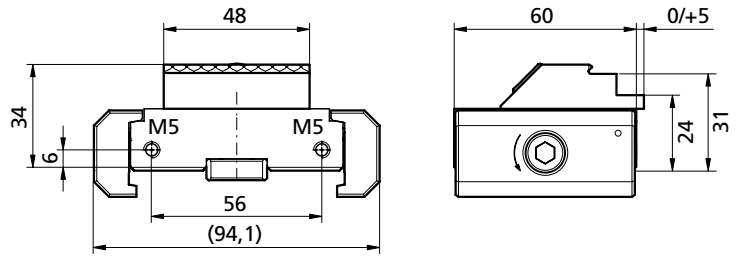
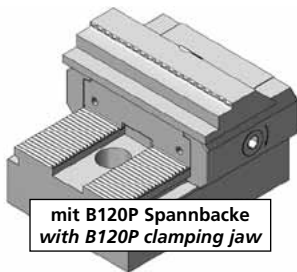
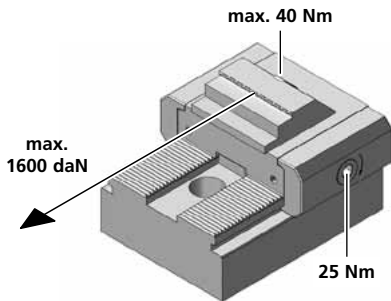

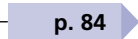
PS5X48L34-105	
1	1x TB210599
2	1x 
3	1x PCSP60R
4	1x PCSP60L
5	1x PCS14
6	1x PCGU2059
7	1x M6X8ISO7380
8	2x M5X14ISO4762
9	2x PCD005
10	1x M8X28ISO4762
11	1x PCUSR16
12	1x PCKMR45M8
13	2x BN869d=6
kg	~0,9

Bestellbeispiel / Ordering example:  
1x PS5X48L34-105 & 1x B105

Drehmoment Torque		Spannkraft Workholding force		
Nm	(lb-ft)	~daN	~(lb)	~t
10	7,4	= 400	880	0,4
20	14,8	= 800	1'760	0,8
30	22,2	= 1'200	2'650	1,2
40	29,6	= 1'600	3'530	1,6

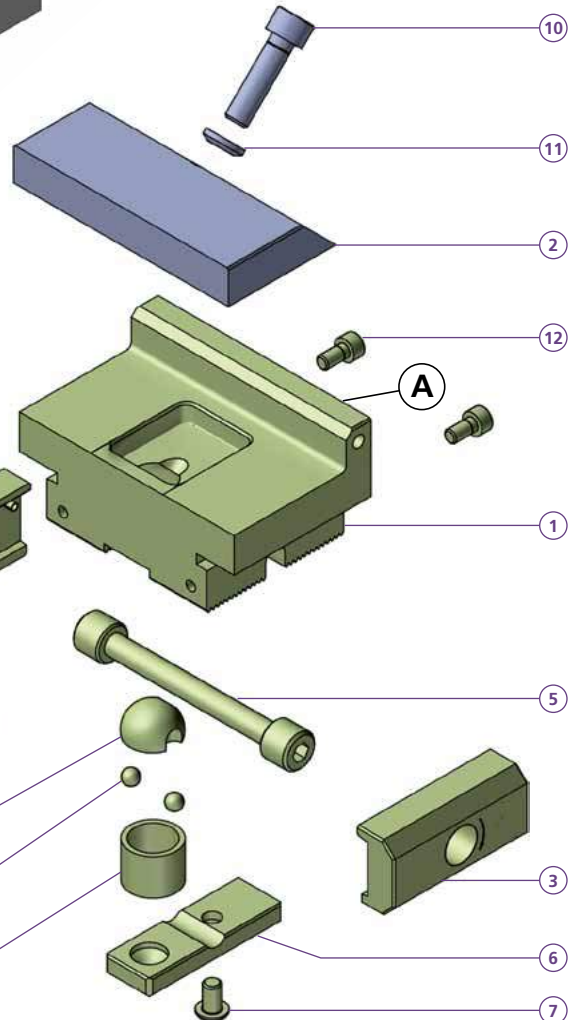
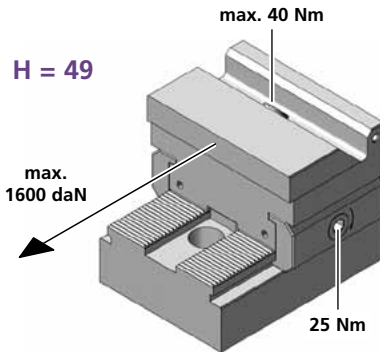
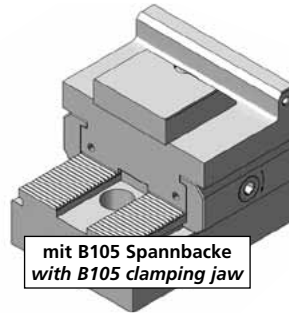
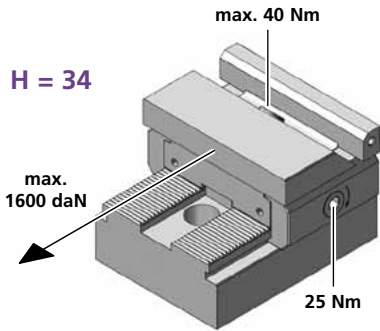
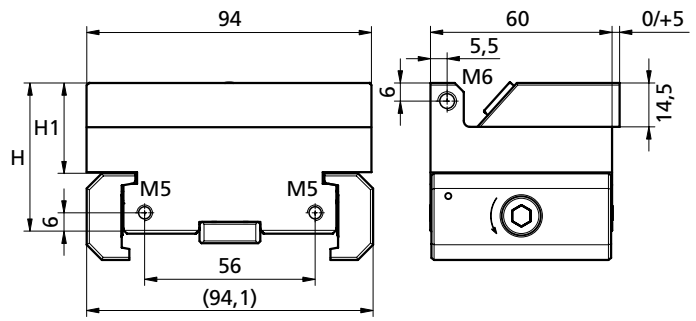
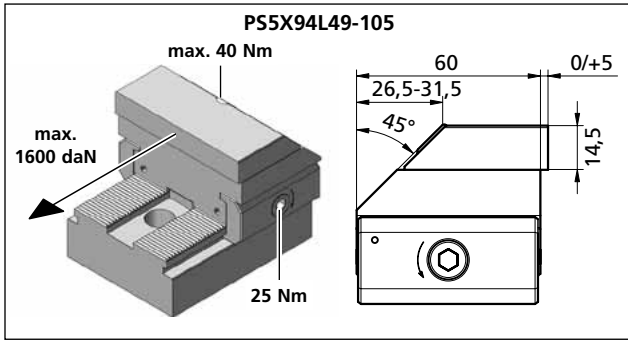

	<b>PS5X94L49-105</b>
1	1x TW100186
15	2x PCD20L15
9	2x PCD005
8	2x M5X14ISO4762
kg	~1,5
	<b>PS1F94L34-105</b>
1	1x TH130785
	<b>PS1R94L34-105</b>
1	1x TH130786
2	1x <b>p. 84</b>
3	1x PCSP60R
4	1x PCSP60L
5	1x PCS14
6	1x PCGU2059
7	1x M6X8ISO7380
8	2x M5X14ISO4762
9	2x PCD005
10	1x M8X30ISO4762
11	1x PCUSR14
12	2x M5X10ISO4762
13	1x PCKMR45M8
14	2x BN869d=6
H	= 34
H1	= 15
kg	~1,0

	<b>PS1F94L49-105</b>
1	1x TF140674
15	2x PCD20L15
	<b>PS1R94L49-105</b>
1	1x TF140675
15	2x PCD20L15
H	= 49
H1	= 30
kg	~1,7

Bestellbeispiel / Ordering example:  
1x PS1R94L49-105 & 1x B105

Drehmoment Torque		Spannkraft Workholding force		
Nm	(lb-ft)	~daN	~(lb)	~t
10	7,4	= 400	880	0,4
20	14,8	= 800	1'760	0,8
30	22,2	= 1'200	2'650	1,2
40	29,6	= 1'600	3'530	1,6



PS1R48L49-105H20  
PS1R94L49-105H20

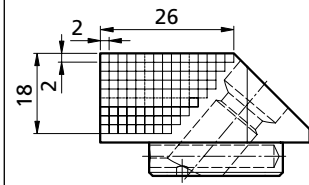

Zum Erstellen Ihrer individuellen Formbacke: *If a dedicated jaw is being machined:*  
Schnittzeichnung zum Ermitteln der maximalen Bearbeitungsprofiltiefe *Sectional drawing to determine the maximum machining depth*

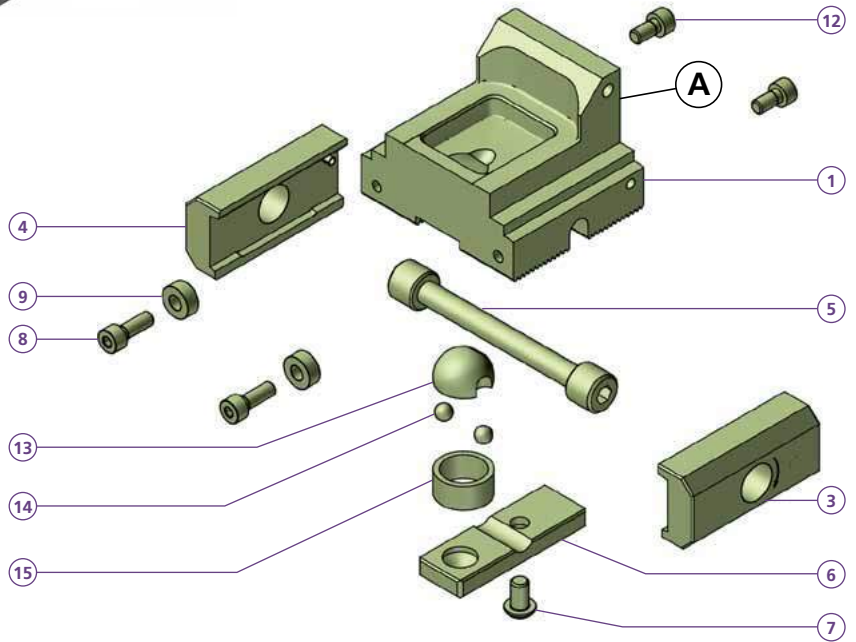
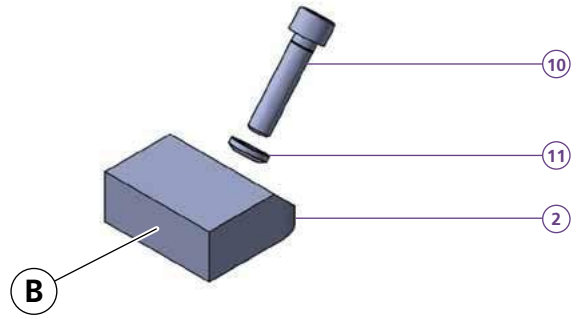
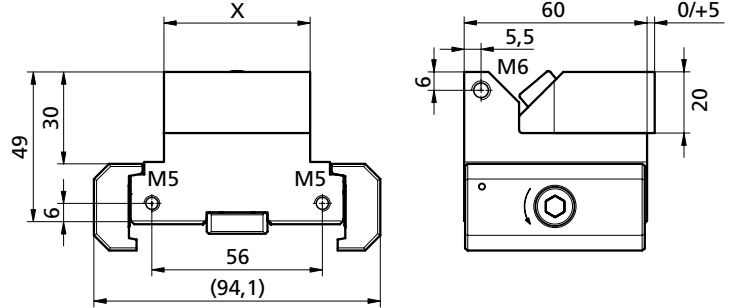
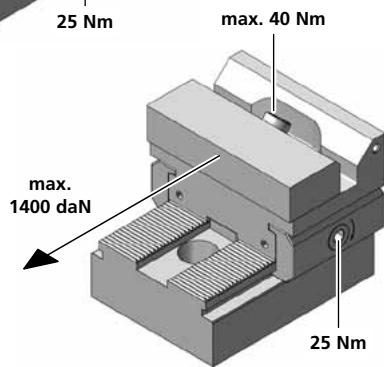
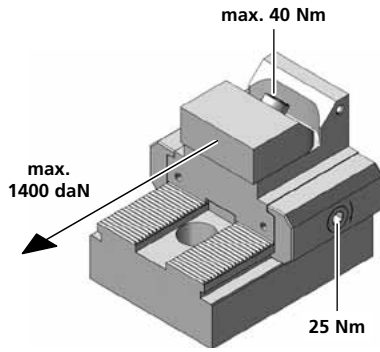

<b>PS1R48L49-105H20</b>	
1	1x TW100161-01
2	1x
3	1x PCSP60R
4	1x PCSP60L
5	1x PCS14
6	1x PCGU2059
7	1x M6X8ISO7380
8	2x M5X14ISO4762
9	2x PCD005
10	1x M8X35ISO4762
11	1x PCUSR14
12	2x M5X10ISO4762
13	1x PCKMR45M8
14	2x BN869d=6
15	1x PCD20L095
X	= 48
kg	~1,2
<b>PS1R94L49-105H20</b>	
1	1x TW100161-07
X	= 94
kg	~1,5

Bestellbeispiel / Ordering example: 1x PS1R48L49-105H20 & 1x B107H20

	B105H20	B106H20	B107H20	B110H20	B111H20	B112H20
C	48	48	48	94	94	94
H	20	20	20	20	20	20
L	47	47	47	47	47	47
i	HV700 x0,2mm	HV700 x0,2mm	*	HV700 x0,2mm	HV700 x0,2mm	*
kg	~0,38	~0,38	~0,38	~0,57	~0,56	~0,56

Separat bestellen / Separate order

PS1R125L49-105H20

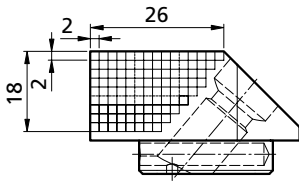

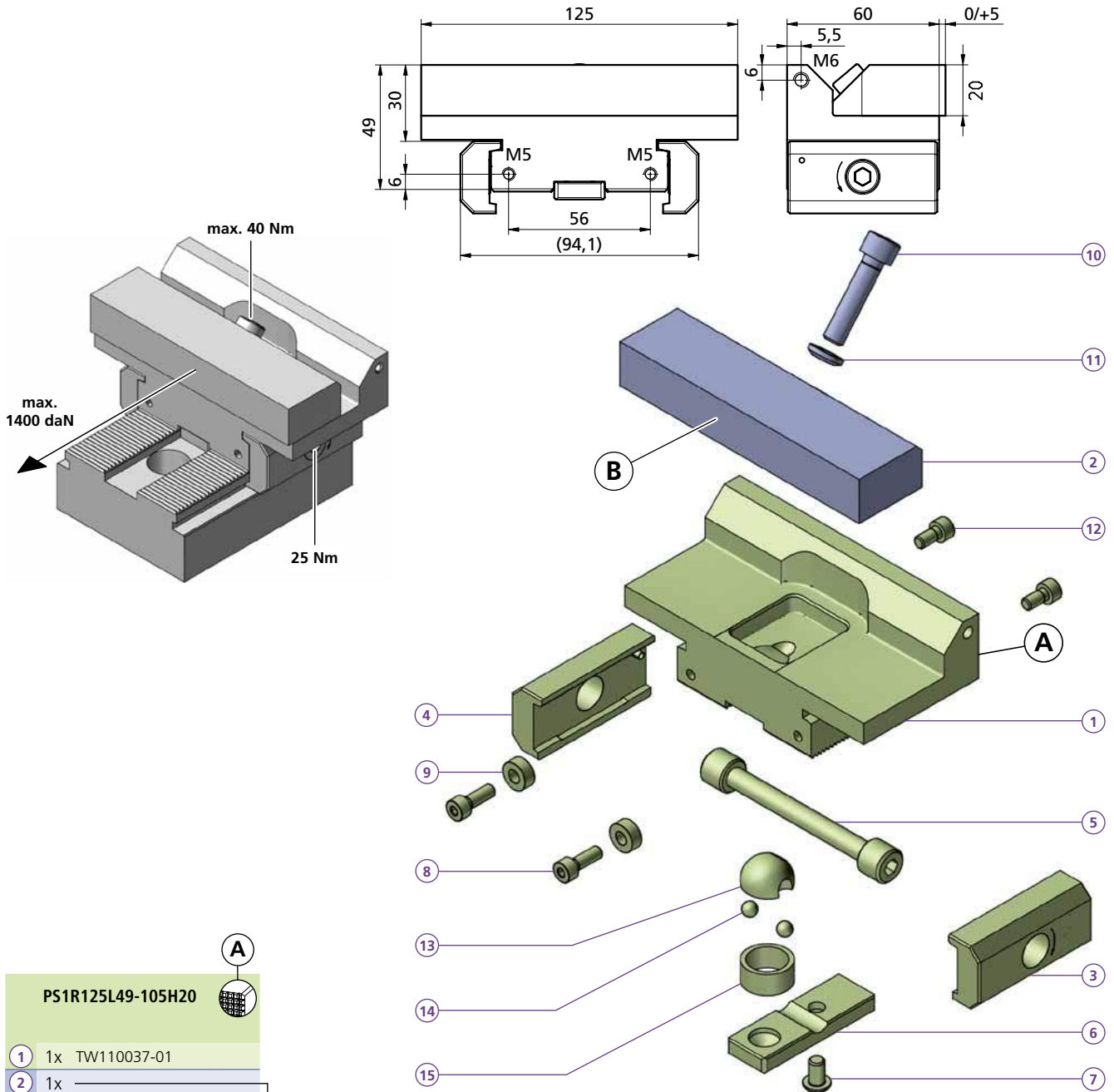

Zum Erstellen Ihrer individuellen Formbacke: *If a dedicated jaw is being machined:*  
 Schnittzeichnung zum Ermitteln der maximalen Bearbeitungsprofiltiefe  
*Sectional drawing to determine the maximum machining depth*



PS1R125L49-105H20 	
1	1x TW110037-01
2	1x 
3	1x PCSP60R
4	1x PCSP60L
5	1x PCS14
6	1x PCGU2059
7	1x M6X8ISO7380
8	2x M5X14ISO4762
9	2x PCD005
10	1x M8X35ISO4762
11	1x PCUSR14
12	2x M5X10ISO4762
13	1x PCKMR45M8
14	2x BN869d=6
15	1x PCD20L095
kg	~1,7

Bestellbeispiel / Ordering example: 1x PS1R125L49-105H20 & 1x B132H20P

	 B130H20P	 B131H20P	 B132H20P
C	125	125	125
H	20	20	20
L	47	47	47
i	HV700 x0,2mm	HV700 x0,2mm	*
kg	~0,71	~0,71	~0,71

B130H20P, B131H20P, B132H20P

\* = weicher Stahl / soft steel

Separat bestellen / Separate order

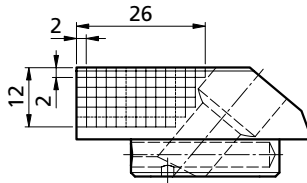

**Zum Erstellen Ihrer individuellen Formbacke: *If a dedicated jaw is being machined:***  
Schnittzeichnung zum Ermitteln der maximalen Bearbeitungsprofiltiefe *Sectional drawing to determine the maximum machining depth*

für / for B107, B107P, B112, B112P, B112E, B112EP, 112HG

B105... , B106P, B107... , B110... , B111... , B112..., B140... , B141...

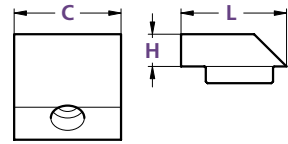

- 3 1x M8X30ISO4762
- 4 1x PCUSR14

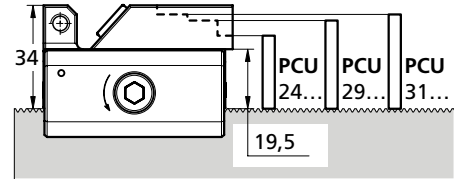
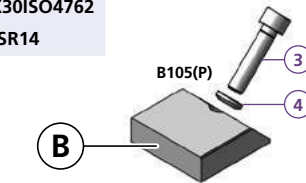

B108... , B113...

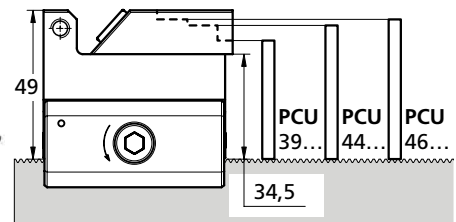
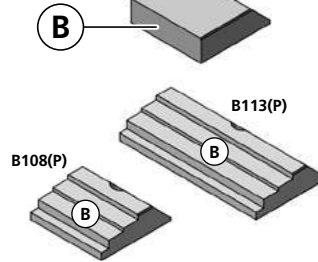
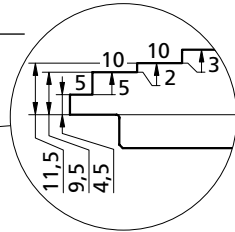
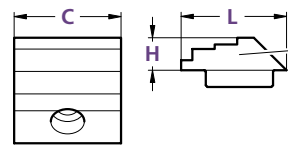

B115... , B120...

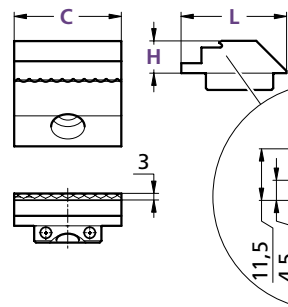

- 3 1x M8X28ISO4762
- 4 1x PCUSR16

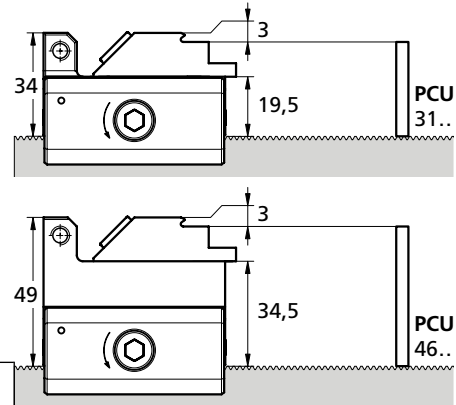
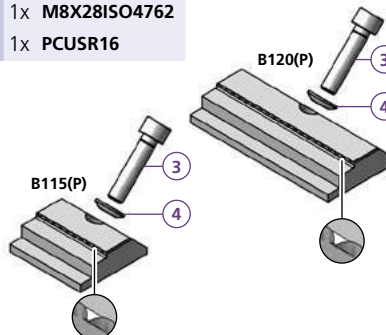
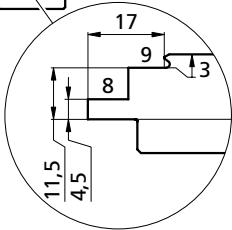

B105-15

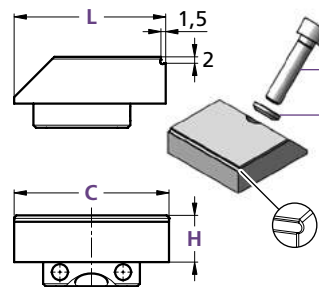

- 3 1x M8X30ISO4762
- 4 1x PCUSR14

B116P, B117P

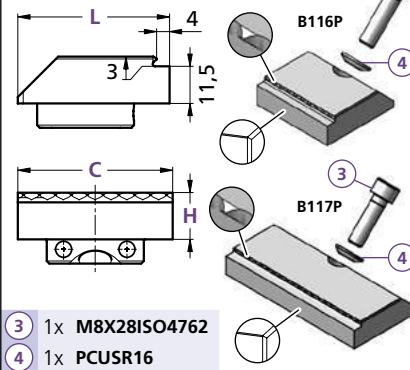

- 3 1x M8X28ISO4762
- 4 1x PCUSR16

Krafterhaltung mit Nachfederung  
*Spring loaded mechanism to maintain clamping force*

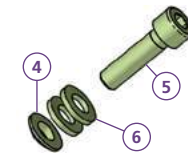

- PF-SET**
- 4 1x PCUSR16
  - 5 1x M8X30ISO4762
  - 6 2x TH160577

Tellerfedern gegenläufig montieren

Mount the clamping disc springs in opposite directions

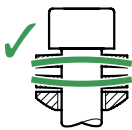

Für Prägebacken  
*For stamping jaws*

B

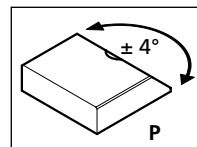

	B105	B105-15	B106	B107	B108	B110	B111	B112	B112E	B113	B115	B116P	B117P	B120	B140	B141
	B105P		B106P	B107P	B108P	B110P	B111P	B112P	B112EP	B113P	B115P	B116P	B117P	B120P	B140P	B141P
C	48	48	48	48	48	94	94	94	94	94	48	48	94	94	78	78
H	14,5	14,5	14,5	14,5	14,5	14,5	14,5	14,5	14,5	14,5	14,5	14,5	14,5	14,5	14,5	14,5
L	47	47	47	47	47	47	47	47	47	47	47	47	47	47	47	47
i	HV700	HV700	HV700	*	HV700	HV700	HV700	*	**	HV700	57HRC	57HRC	57HRC	57HRC	HV700	HV700
	x0,2mm	x0,2mm	x0,2mm		x0,2mm	x0,2mm	x0,2mm			x0,2mm				x0,2mm	x0,2mm	x0,2mm
kg	~0,27	~0,27	~0,27	~0,27	~0,22	~0,49	~0,48	~0,49	~0,47	~0,39	~0,21	~0,25	~0,46	~0,4	~0,41	~0,41



**Anschlagmodule**  
*End module*

**PAND19-49**

**PAND26-49**

**PAND34-49**

**PA5X19-49R/F**

**PA5X26-49R/F**

**PA5X34-49R/F**



**powerCLAMP**

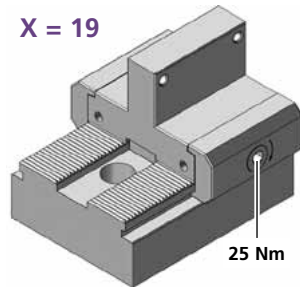
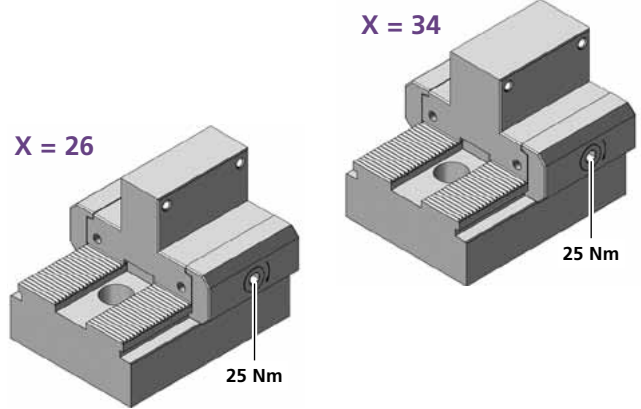
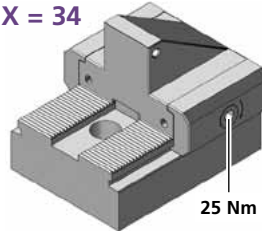
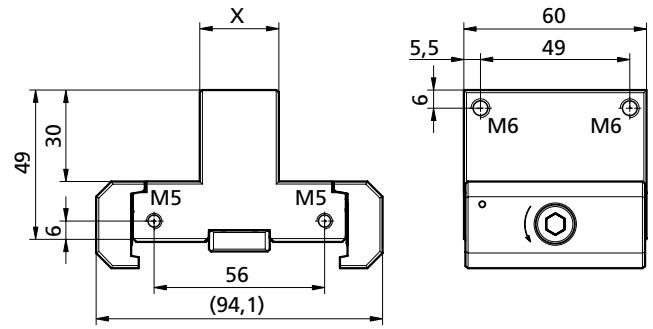
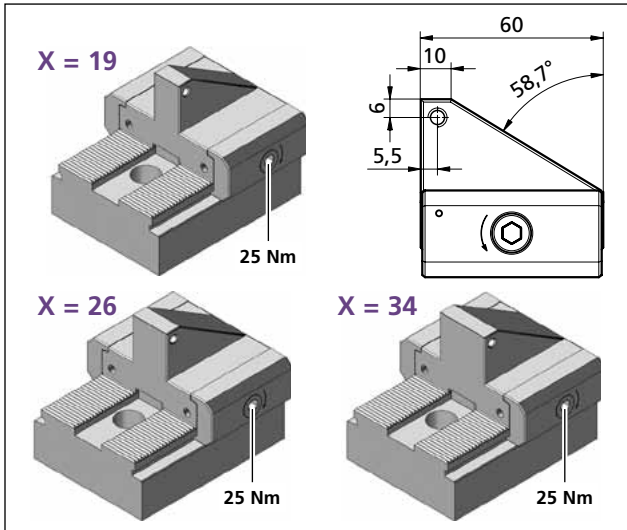

	<b>PA5X19-49R</b>	
	1x TF140617	
	2x M5X10ISO4762	
	<b>PA5X19-49F</b>	
	1x TF140618	
	2x M5X10ISO4762	
kg	~1,1	
	<b>PAND19-49</b>	
	1x TF140619	
	1x PCSP60R	
	1x PCSP60L	
	1x PCS14	
	1x PCGU2049	
	1x M6X8ISO7380	
	4x M5X10ISO4762	
X	= 19	
kg	~1,2	
	<b>PA5X26-49R</b>	
	1x TF140621	
	2x M5X10ISO4762	
	<b>PA5X26-49F</b>	
	1x TF140620	
	2x M5X10ISO4762	
kg	~1,2	
	<b>PAND26-49</b>	
	1x TF140622	
X	= 26	
kg	~1,3	

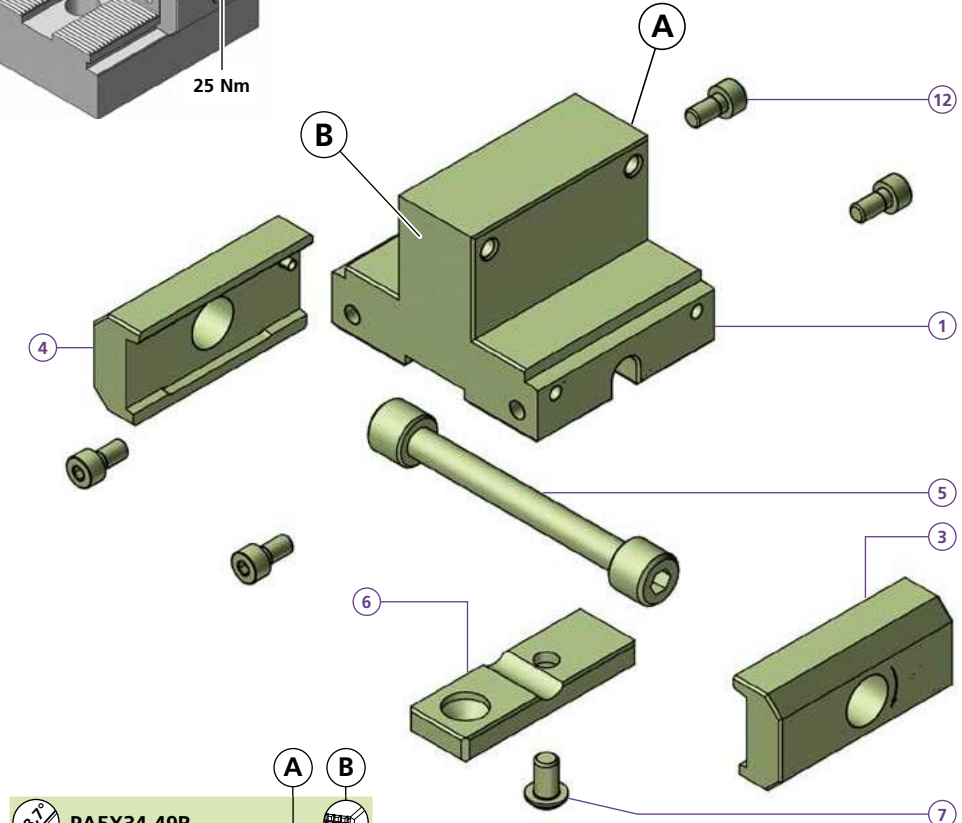

	<b>PA5X34-49R</b>	
	1x TF140024	
	2x M5X10ISO4762	
	<b>PA5X34-49F</b>	
	1x TF140023	
	2x M5X10ISO4762	
kg	~1,3	
	<b>PAND34-49</b>	
	1x TF140625	
X	= 34	
kg	~1,6	

Bestellbeispiel / Ordering example: **PAND19-49**

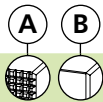
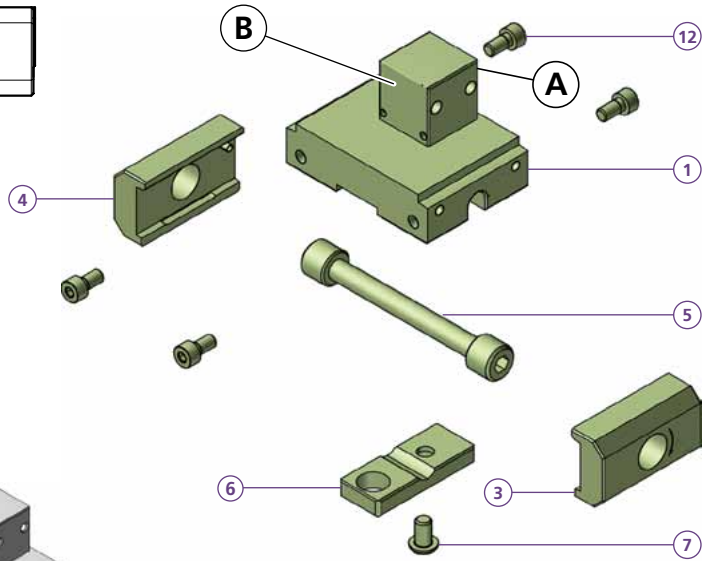
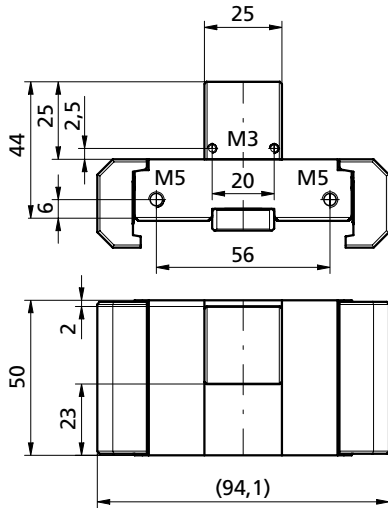

**PAND25-44**

- ① 1x TF140626
  - ③ 1x PCSP50R
  - ④ 1x PCSP50L
  - ⑤ 1x PCS14
  - ⑥ 1x PCGU2049
  - ⑦ 1x M6X8ISO7380
  - ⑫ 4x M5X10ISO4762
- kg ~0,9

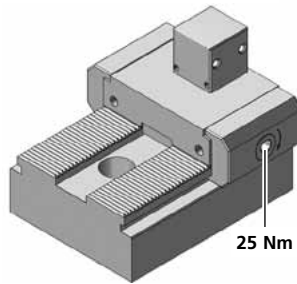

Bestellbeispiel / Ordering example: PAND25-44

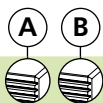
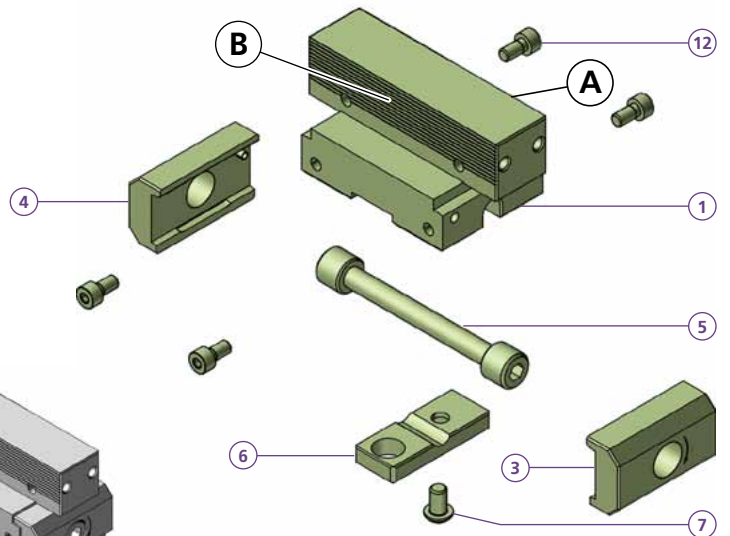
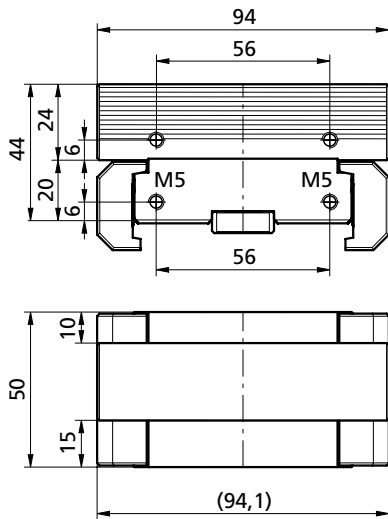

**PAND94-44**

- ① 1x TF140627
  - ③ 1x PCSP50R
  - ④ 1x PCSP50L
  - ⑤ 1x PCS14
  - ⑥ 1x PCGU2049
  - ⑦ 1x M6X8ISO7380
  - ⑫ 4x M5X10ISO4762
- kg ~1,3

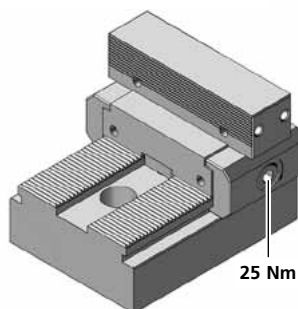

Bestellbeispiel / Ordering example: PAND94-44

PAND48-34

PAND48-75

PAND58-34

PAND58-49

PAND61-34



powerCLAMP

X = 48  
H = 34

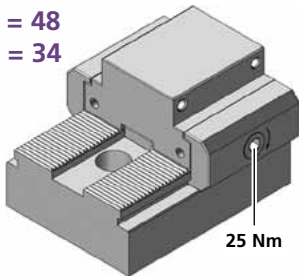

25 Nm

X = 48  
H = 75

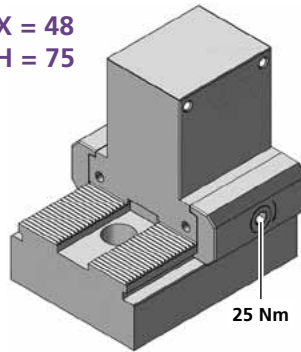

25 Nm

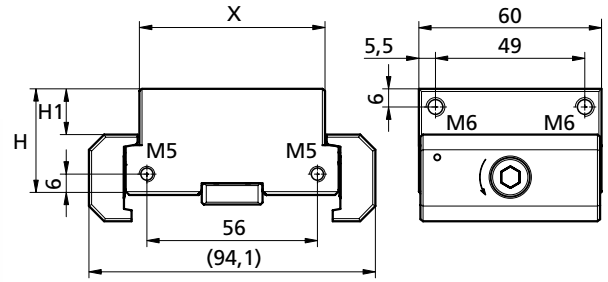

	A	B
<b>PAND48-34</b>		
1	1x TF140628	
3	1x PCSP60R	
4	1x PCSP60L	
5	1x PCS14	
6	1x PCGU2049	
7	1x M6X8ISO7380	
12	4x M5X10ISO4762	
X	= 48	
H	= 34	
H1	= 15	
kg	~1,3	
<b>PAND48-75</b>		
1	1x TK120053	
X	= 48	
H	= 75	
H1	= 56	
kg	~2,2	
<b>PAND58-34</b>		
1	1x TF140629	
X	= 58	
H	= 34	
H1	= 15	
kg	~1,4	
<b>PAND58-49</b>		
1	1x TK120130	
X	= 58	
H	= 49	
H1	= 30	
kg	~1,8	
<b>PAND61-34</b>		
1	1x TF140630	
X	= 61	
H	= 34	
H1	= 15	
kg	~1,4	

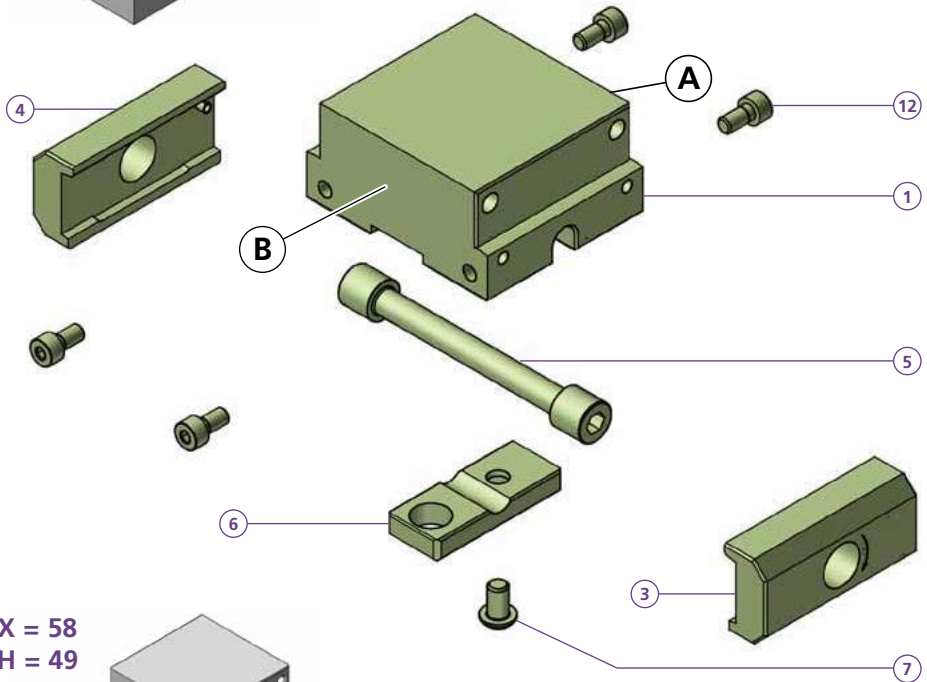

X = 58  
H = 49

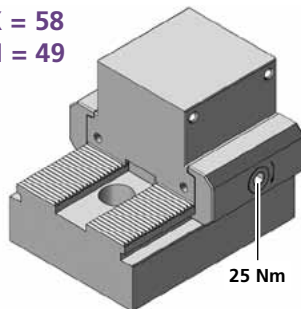

25 Nm

X = 58  
H = 34

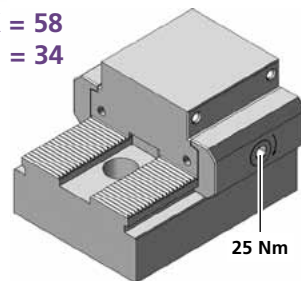

25 Nm

X = 61  
H = 34

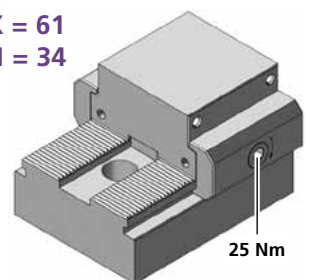

25 Nm

Bestellbeispiel / Ordering example: PAND61-34





X = 68  
H = 34

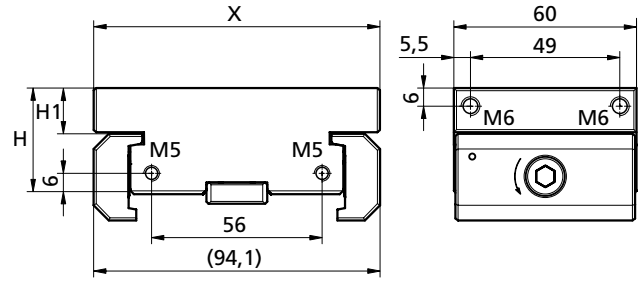
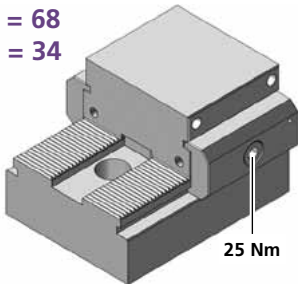

X = 78  
H = 34

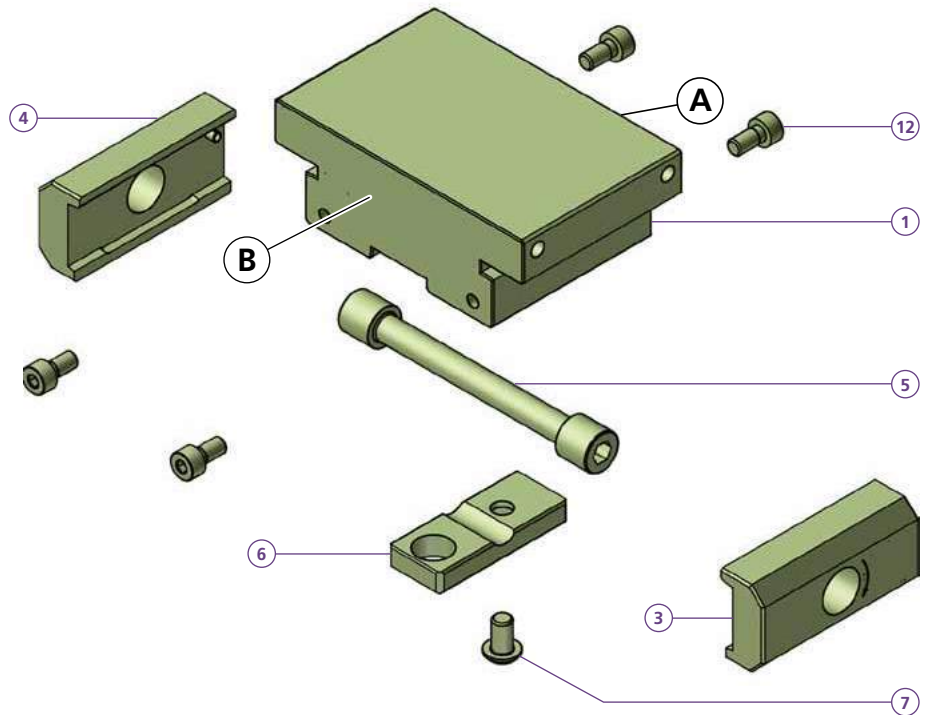
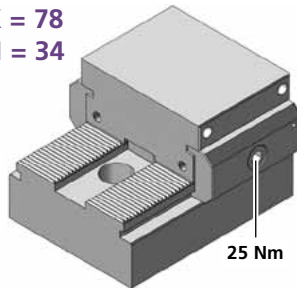

**PAND68-34**

- ① 1x TF140631
- ③ 1x PCSP60R
- ④ 1x PCSP60L
- ⑤ 1x PCS14
- ⑥ 1x PCGU2049
- ⑦ 1x M6X8ISO7380
- ⑫ 4x M5X10ISO4762
- X = 68
- H = 34
- H1 = 15
- kg ~1,4

**PAND78-34**

- ① 1x TF140632
- X = 78
- H = 34
- H1 = 15
- kg ~1,5

**PAND94-34**

- ① 1x TF140633
- X = 94
- H = 34
- H1 = 15
- kg ~2,3

**PAND78-49**

- ① 1x TF140634
- X = 78
- H = 49
- H1 = 30
- kg ~2,0

X = 94  
H = 34

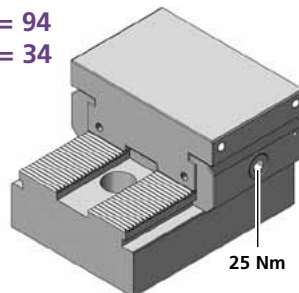

X = 78  
H = 49

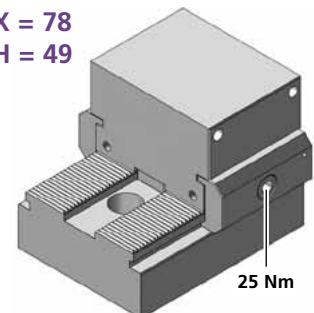

Bestellbeispiel / Ordering example: PAND94-34

PAND43-49

PAND125-49

PA5X94-49R/F

PAND48-49

PA5X43-49R/F

PA5X125-49R/F

PAND94-49

PA5X48-49R/F



powerCLAMP

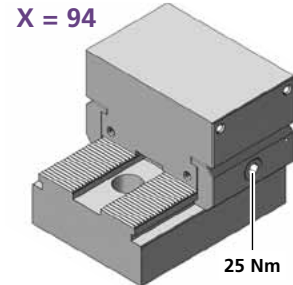
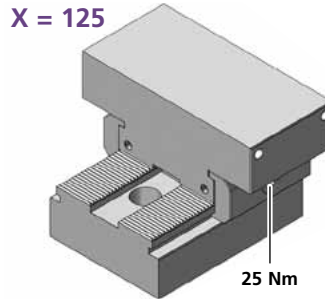
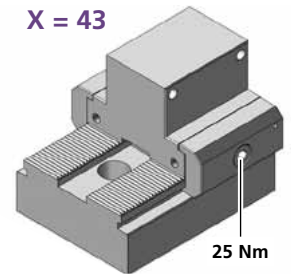
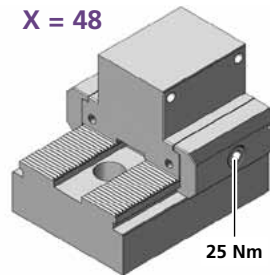
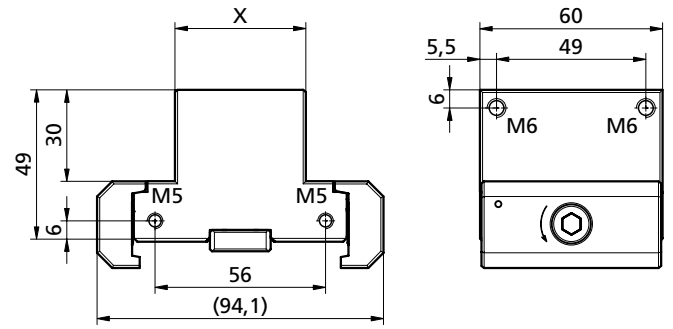
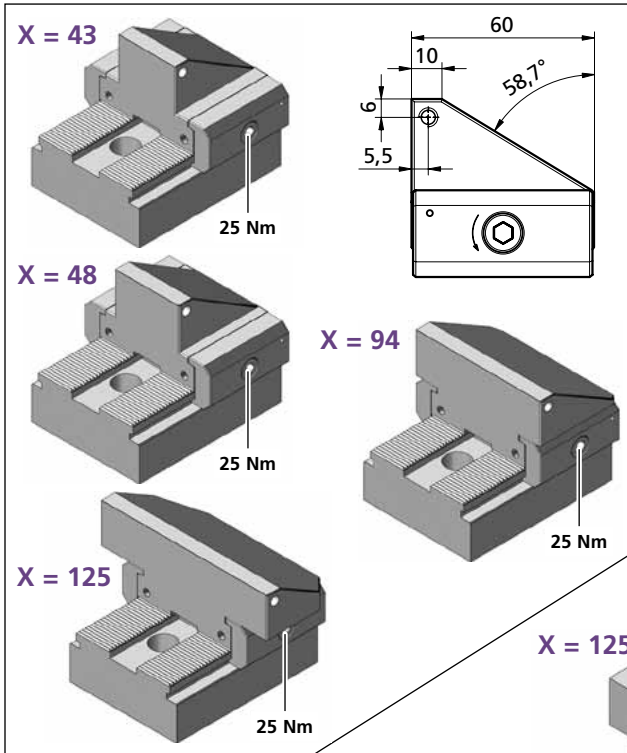

	<b>PA5X43-49R</b>	
	1x TF140651	
	2x M5X10ISO4762	
	<b>PA5X43-49F</b>	
	1x TF140652	
	2x M5X10ISO4762	
kg	~1,3	
	<b>PAND43-49</b>	
	1x TF140659	
	1x PCSP60R	
	1x PCSP60L	
	1x PCS14	
	1x PCGU2049	
	1x M6X8ISO7380	
	4x M5X10ISO4762	
X	= 43	
kg	~1,6	
	<b>PA5X48-49R</b>	
	1x TF140653	
	2x M5X10ISO4762	
	<b>PA5X48-49F</b>	
	1x TF140654	
	2x M5X10ISO4762	
kg	~1,3	
	<b>PAND48-49</b>	
	1x TF140660	
X	= 48	
kg	~1,6	

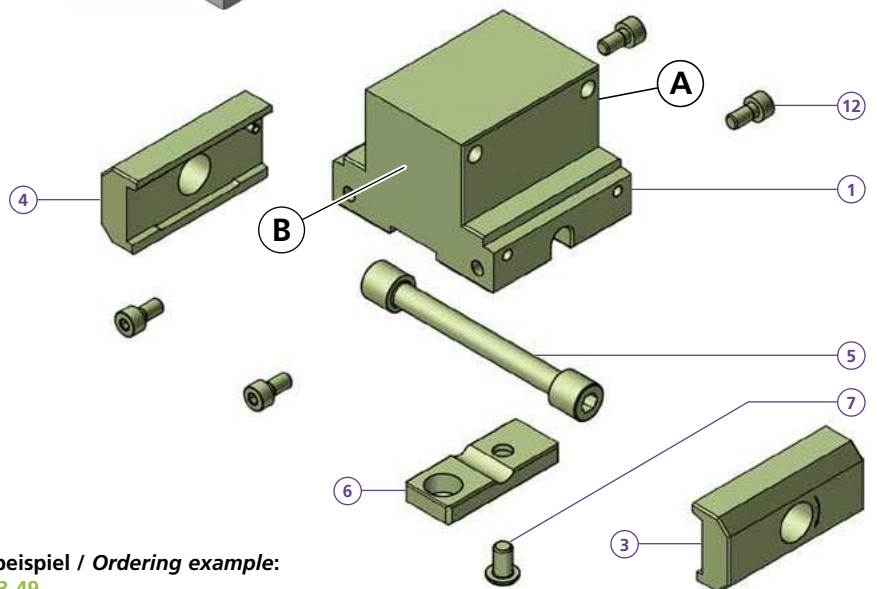



Bestellbeispiel / Ordering example:  
PAND43-49

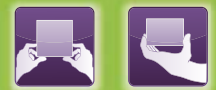

	<b>PA5X94-49R</b>	
	1x TF140655	
	2x M5X10ISO4762	
	<b>PA5X94-49F</b>	
	1x TF140656	
	2x M5X10ISO4762	
kg	~1,7	
	<b>PAND94-49</b>	
	1x TB150451	
X	= 94	
kg	~2,3	

	<b>PA5X125-49R</b>	
	1x TF140657	
	2x M5X10ISO4762	
	<b>PA5X125-49F</b>	
	1x TF140658	
	2x M5X10ISO4762	
kg	~2,0	
	<b>PAND125-49</b>	
	1x TF140662	
X	= 125	
kg	~2,7	



**PAND48-34PRG-A1**   



1 1x TH120684

**PAND48-34PRF-A1**   

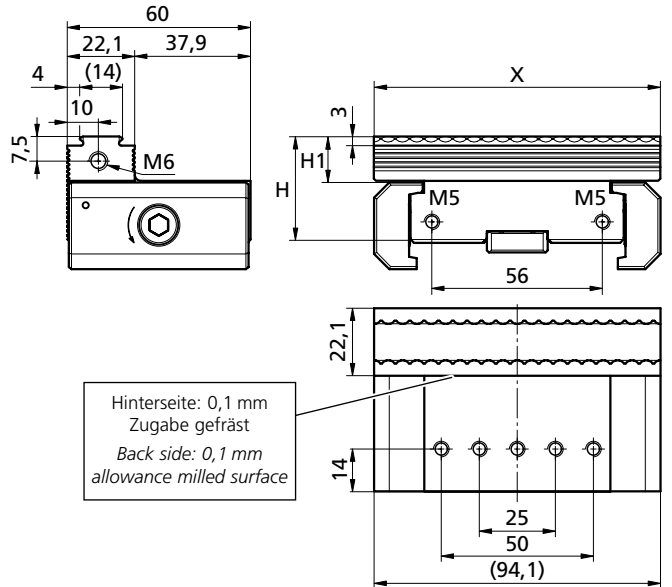
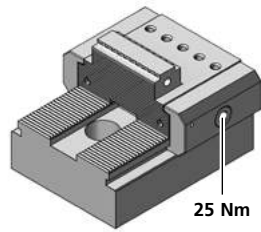

1 1x TK140239  
 3 1x PCSP60R  
 4 1x PCSP60L  
 5 1x PCS14  
 6 1x PCGU2049  
 7 1x M6X8ISO7380  
 12 4x M5X10ISO4762

X = 48  
 H = 34  
 H1 = 15  
 kg ~1,1



**PAND48-49PRG-A1**   



1 1x TH120685

**PAND48-49PRF-A1**   

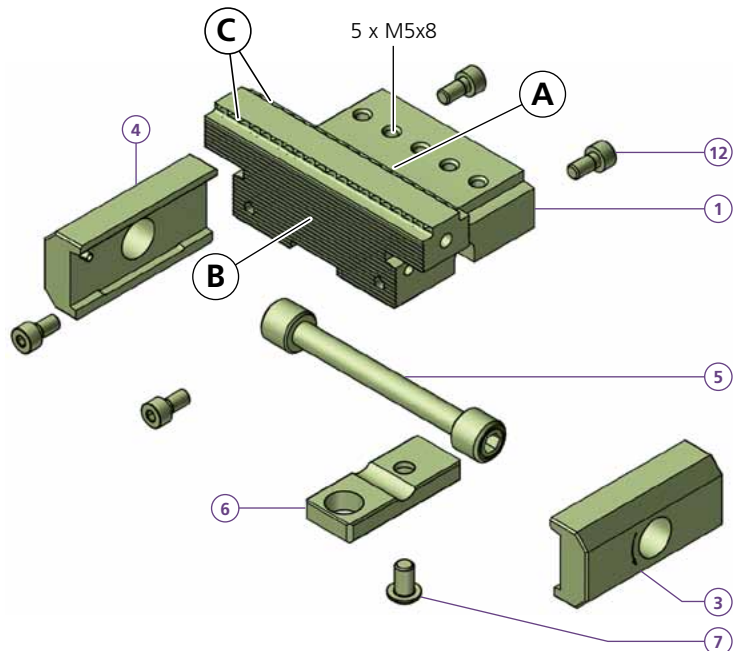
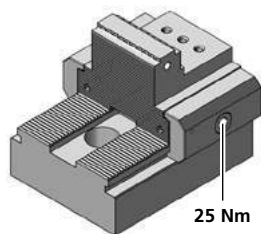

1 1x TK140597

X = 48  
 H = 49  
 H1 = 30  
 kg ~1,3



**PAND94-34PRG-A1**   



1 1x TH120686

**PAND94-34PRF-A1**   

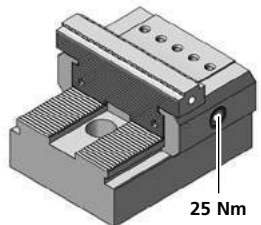

1 1x TH140185

X = 94  
 H = 34  
 H1 = 15  
 kg ~1,2



**PAND94-49PRG-A1**   



1 1x TH120687

**PAND94-49PRF-A1**   

1 1x TH130754

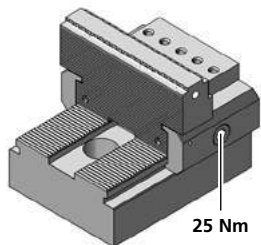
X = 94  
 H = 49  
 H1 = 30  
 kg ~1,6



**PAND125-49PRG-A1**   

1 1x TB160295

X = 125  
 H = 49  
 H1 = 30  
 kg ~1,7

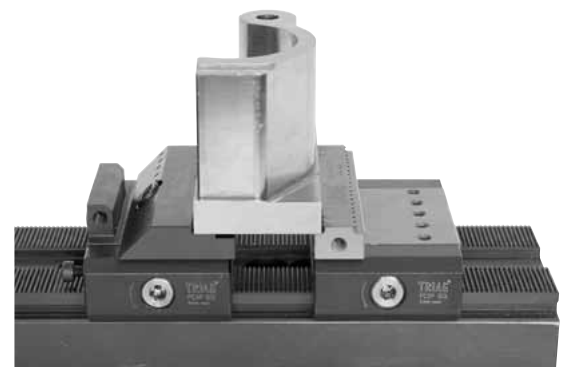
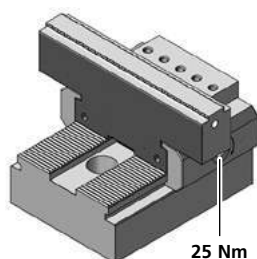

Bestellbeispiel / Ordering example: PAND94-34PRG-A1



PAND125-34PRG-A1

PAND150-34PRG-A1

PAND94-34PRGV

PAND94-49PRGV



prägen  
stamping



powerCLAMP

X = 125

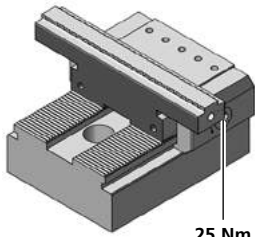

25 Nm

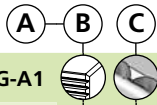

PAND125-34PRG-A1

1 1x TB180899

X = 125

kg ~1,2

PAND150-34PRG-A1

1 1x TB160145

3 1x PCSP50R

4 1x PCSP50L

5 1x PCS14

6 1x PCGU2049

7 1x M6X8ISO7380

12 4x M5X10ISO4762

X = 150

kg ~1,2

X = 150

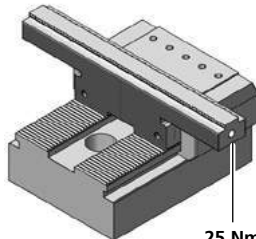

25 Nm

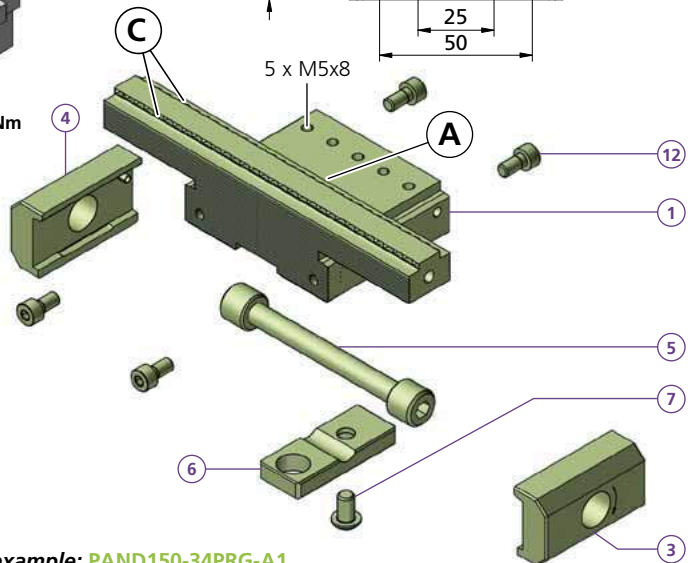
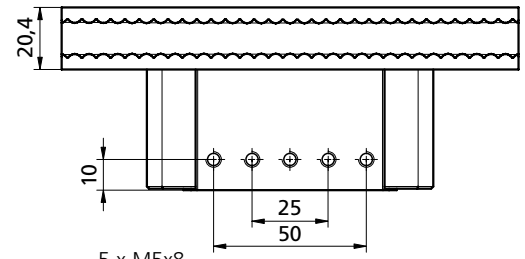
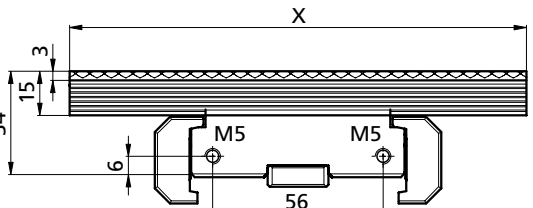
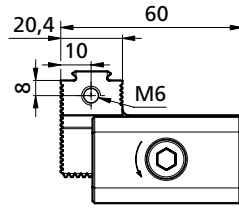

Bestellbeispiel / Ordering example: PAND150-34PRG-A1

H = 34

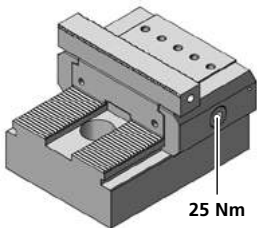

25 Nm



PAND94-34PRGV

1 1x TH171180

3 1x PCSP60R

4 1x PCSP60L

5 1x PCS14

6 1x PCGU2059

7 1x M6X8ISO7380

12 4x M5X10ISO4762

H = 34

H1 = 15

A = 17,5

kg ~1,2

H = 49

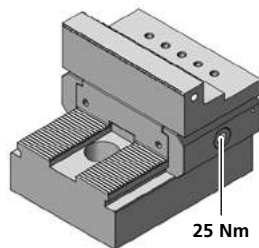

25 Nm



PAND94-49PRGV

1 1x TH171179

H = 49

H1 = 30

A = 17

kg ~1,6

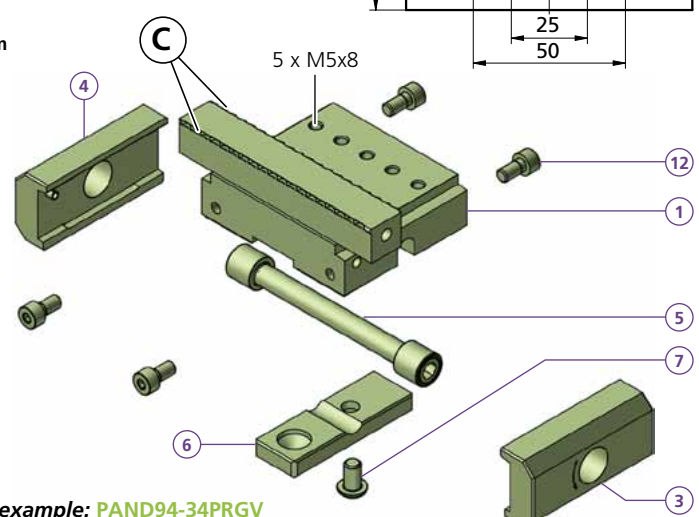
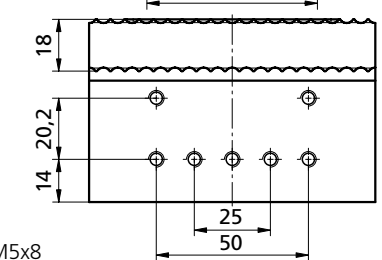
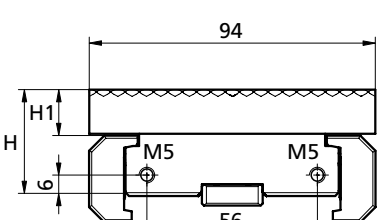
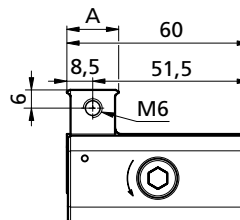

Bestellbeispiel / Ordering example: PAND94-34PRGV



prägen  
stamping



powerCLAMP

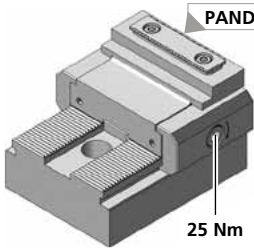

PAND78-34UPRG

25 Nm

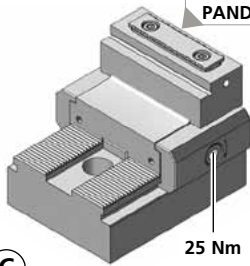

PAND78-49UPRG

25 Nm

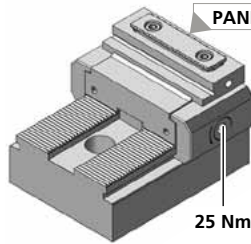

PAND78-34X50UPRG

25 Nm

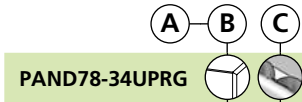
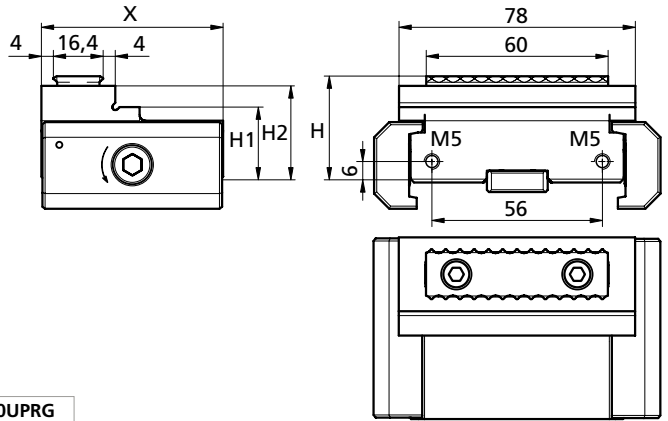

PAND78-34UPRG

- 1 1x TH140038
- 2 1x MAND58-14PRG
- 3 1x PCSP60R
- 4 1x PCSP60L
- 5 1x PCS14
- 6 1x PCGU2049
- 7 1x M6X8ISO7380
- 8 2x M5X16ISO4762

H = 34  
H1 = 24  
H2 = 31  
X = 60  
kg ~1,2

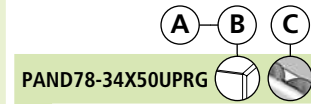

PAND78-34X50UPRG

- 1 1x TB161227
  - 3 1x PCSP50R
  - 4 1x PCSP50L
- H = 34  
H1 = 24  
H2 = 31  
X = 50  
kg ~0,98

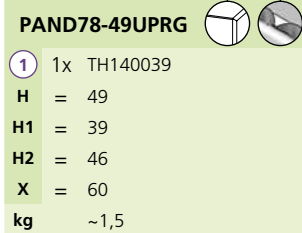

PAND78-49UPRG

- 1 1x TH140039
- H = 49  
H1 = 39  
H2 = 46  
X = 60  
kg ~1,5

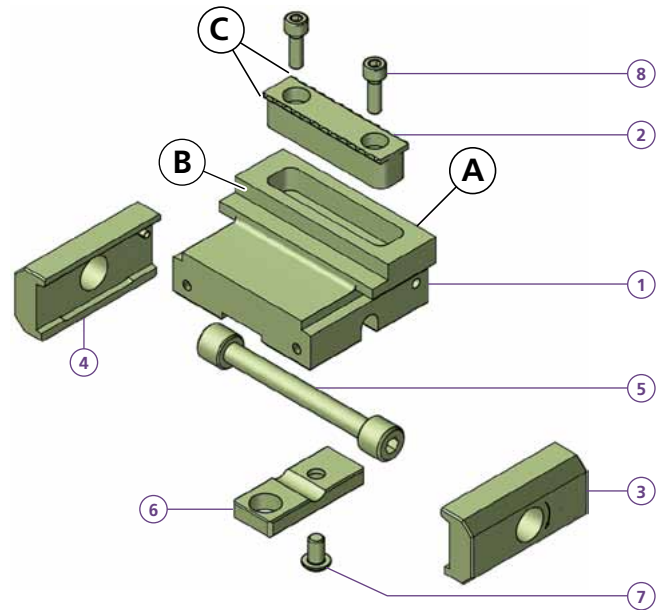

Bestellbeispiel / Ordering example: PAND78-34UPRG

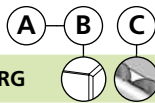
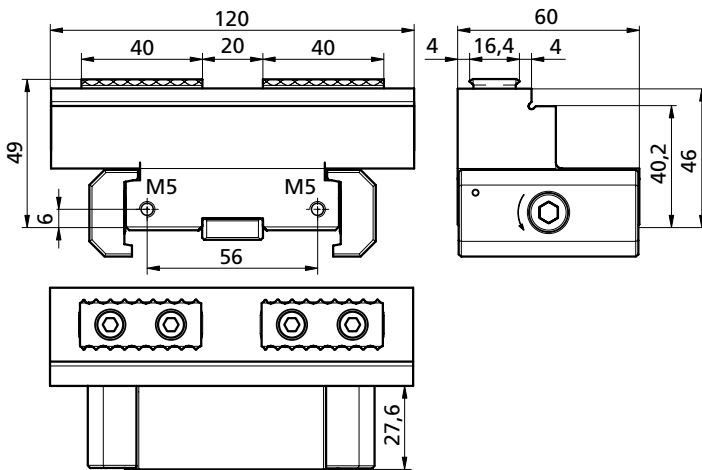

PAND120-49UPRG

- 1 1x TH160318
  - 2 2x MAND38-14PRG
  - 3 1x PCSP60R
  - 4 1x PCSP60L
  - 5 1x PCS14
  - 6 1x PCGU2049
  - 7 1x M6X8ISO7380
  - 8 4x M5X16ISO4762
- kg ~1,7

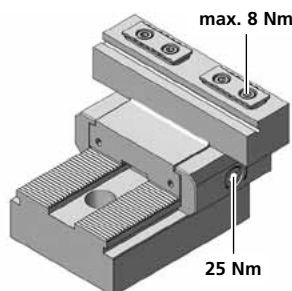

max. 8 Nm

25 Nm

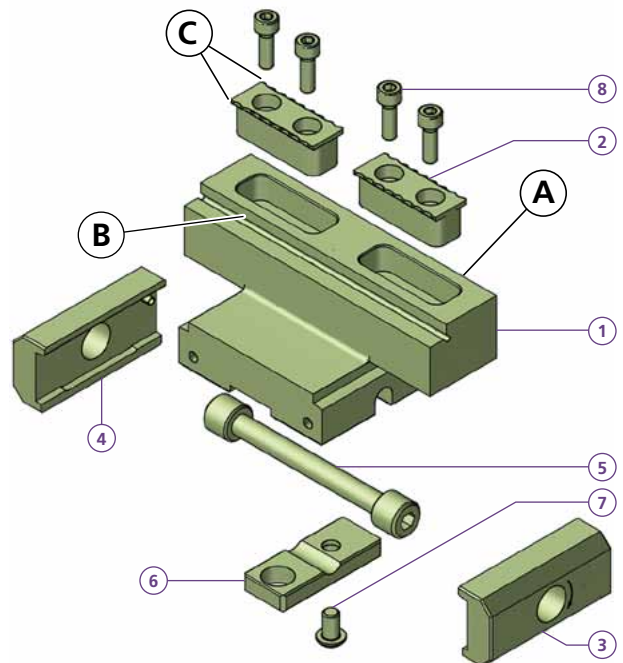

Bestellbeispiel / Ordering example: PAND120-49UPRG

# Rohlingsmodule Blank module

PT-F80-30X60  
PT-F80-30X60NS  
PT-F80-30X30NS

PT-F61-25X60  
PT-F61-25X50  
PT-F61-25X30



powerCLAMP

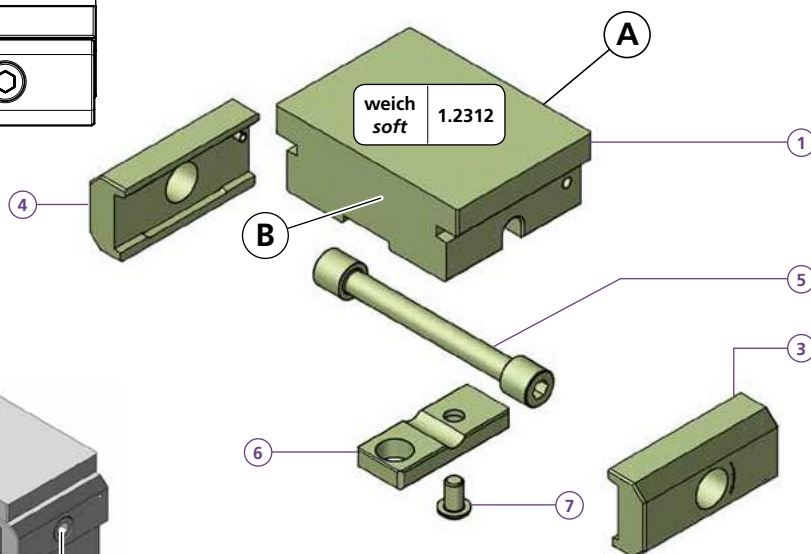
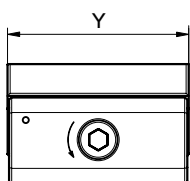
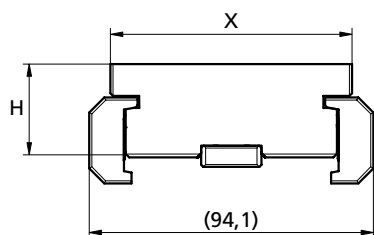

**PT-F80-30X60**

- 1 1x TF140637
- 3 1x PCSP60R
- 4 1x PCSP60L
- 5 1x PCS14
- 6 1x PCGU2049
- 7 1x M6X8ISO7380

X = 80  
H = 30  
Y = 60  
kg ~1,4

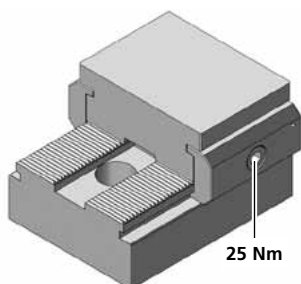

**PT-F80-30X60NS**

NS = Rohlingsmodul freie Positionierung ohne Verzahnung  
Carrier module without positioning serration for free positioning

- 1 1x TF140635
- 3 1x PCSP60R
- 4 1x PCSP60L
- 5 1x PCS14
- 6 1x PCGU2049
- 7 1x M6X8ISO7380

X = 80  
H = 30  
Y = 60  
kg ~1,4

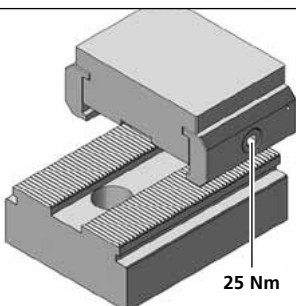

**PT-F80-30X30NS**

NS = Rohlingsmodul freie Positionierung ohne Verzahnung  
Carrier module without positioning serration for free positioning

- 1 1x TF140749
- 3 1x PCSP30R
- 4 1x PCSP30L
- 5 1x PCS14
- 6 1x PCGU2030
- 7 1x M6X8ISO7380

X = 80  
H = 30  
Y = 30  
kg ~0,7

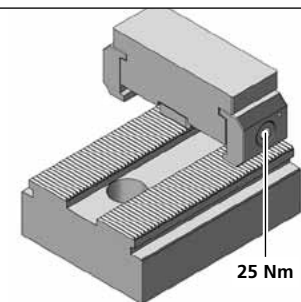

**PT-F61-25X60**

- 1 1x TF140638
- 3 1x PCSP60R
- 4 1x PCSP60L
- 5 1x PCS14
- 6 1x PCGU2049
- 7 1x M6X8ISO7380

X = 61  
H = 25  
Y = 60  
kg ~1,1

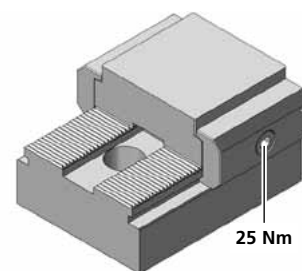

**PT-F61-25X50**

- 1 1x TF140750
- 3 1x PCSP50R
- 4 1x PCSP50L
- 5 1x PCS14
- 6 1x PCGU2049
- 7 1x M6X8ISO7380

X = 61  
H = 25  
Y = 50  
kg ~1,0

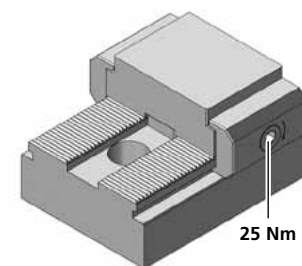

**PT-F61-25X30**

- 1 1x TF140636
- 3 1x PCSP30R
- 4 1x PCSP30L
- 5 1x PCS14
- 6 1x PCGU2049
- 7 1x M6X8ISO7380

X = 61  
H = 25  
Y = 30  
kg ~0,6

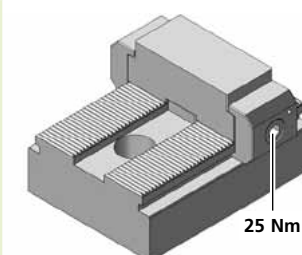

Bestellbeispiel / Ordering example: PT-F80-30X60





A B C

**PR94-49SET**

- 1 1x PR94-49
  - 3 1x PCSP50R
  - 4 1x PCSP50L
  - 5 1x PCS14
  - 6 1x PCGU2049
  - 7 1x M6X8ISO7380
- X = 94  
H = 49  
Y = 60,4  
kg ~2,3

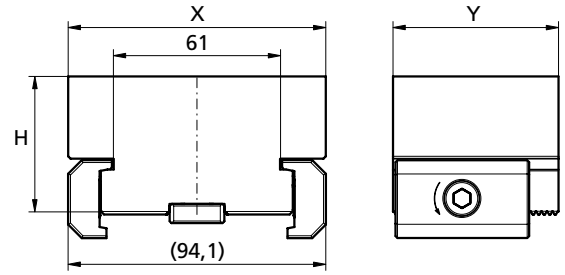
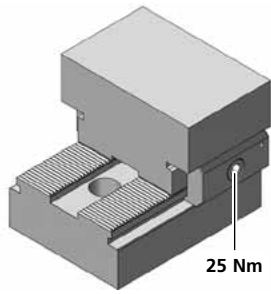

**PR94-39-50SET**

- 1 1x PR94-39-50
- X = 94  
H = 39  
Y = 50,4  
kg ~1,6

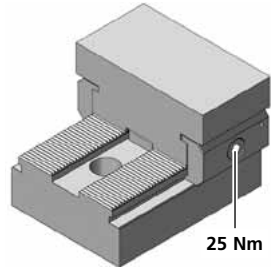

**PR125-49SET**

- 1 1x PR125-49
- X = 125  
H = 49  
Y = 60,4  
kg ~2,7

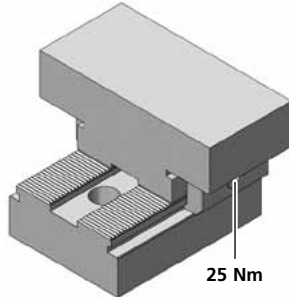

**PR125-49SETALU**

- 1 1x \*PR125-49ALU
- X = 125  
H = 49  
Y = 60,4  
kg ~0,83

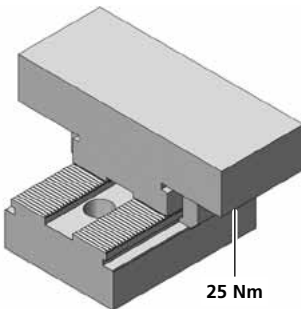

**PR150-49SET**

- 1 1x PR150-49
- X = 150  
H = 49  
Y = 60,4  
kg ~3,1

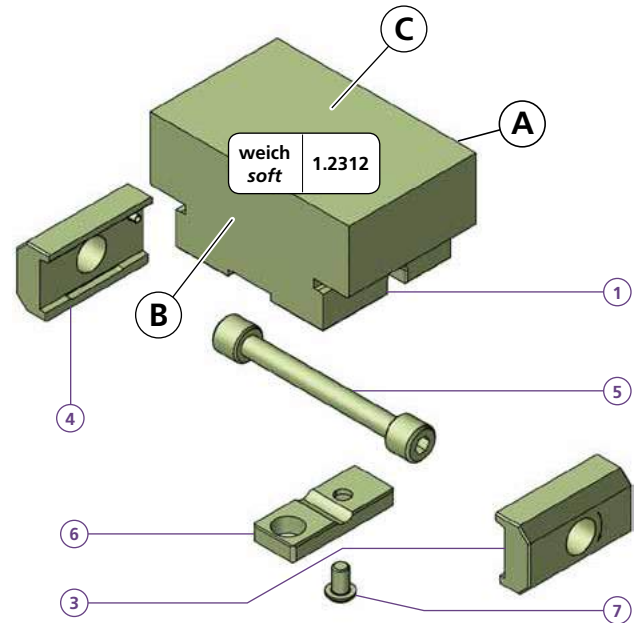

\* ALU = ENAW-7022

Bestellbeispiel / Ordering example: PR94-49SET

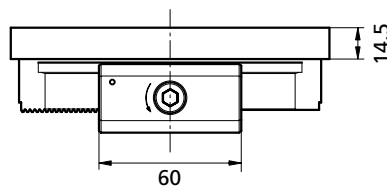
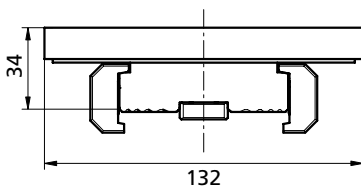

**PT-F132-34RDSET**

- 1 1x PT-F132-34RD
  - 3 1x PCSP60R
  - 4 1x PCSP60L
  - 5 1x PCS14
  - 6 1x PCGU2059
  - 7 1x M6X8ISO7380
- kg ~3,1

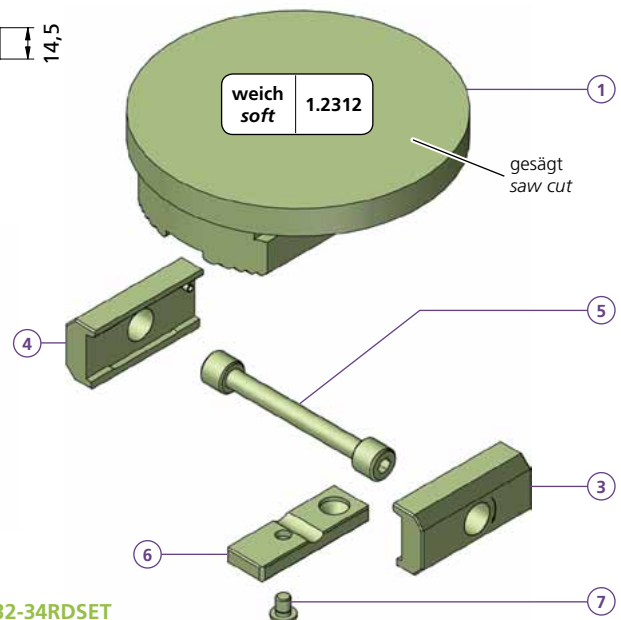
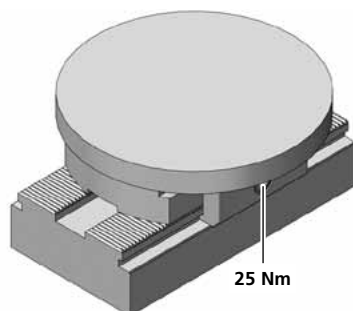

Bestellbeispiel / Ordering example: PT-F132-34RDSET



PTX160-77S

PTX160-57S

powerCLAMP

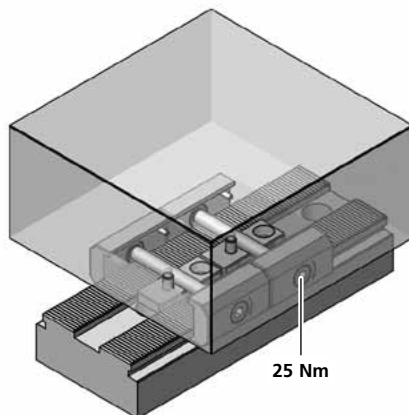
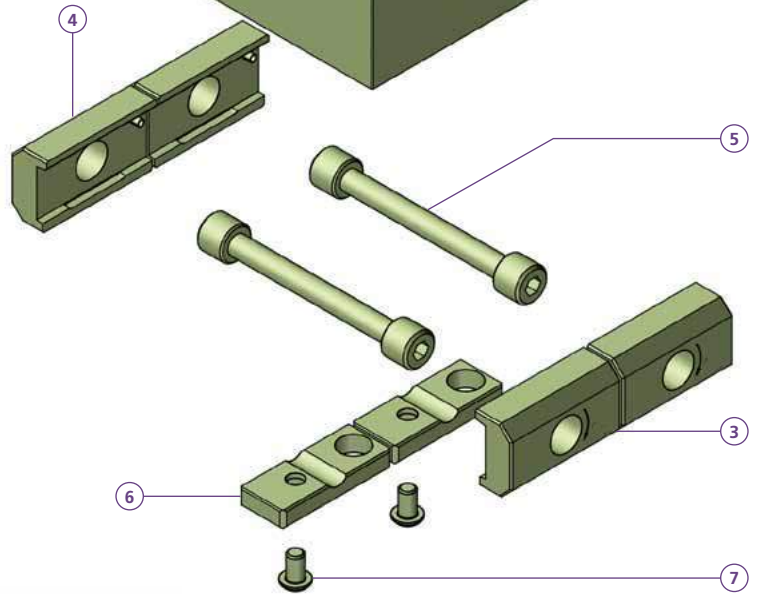
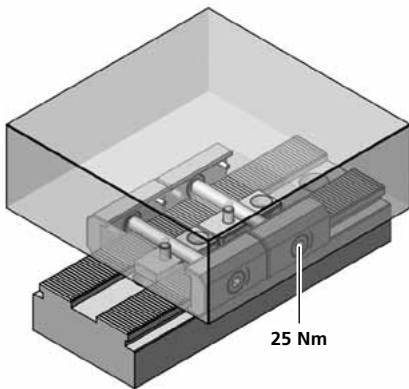
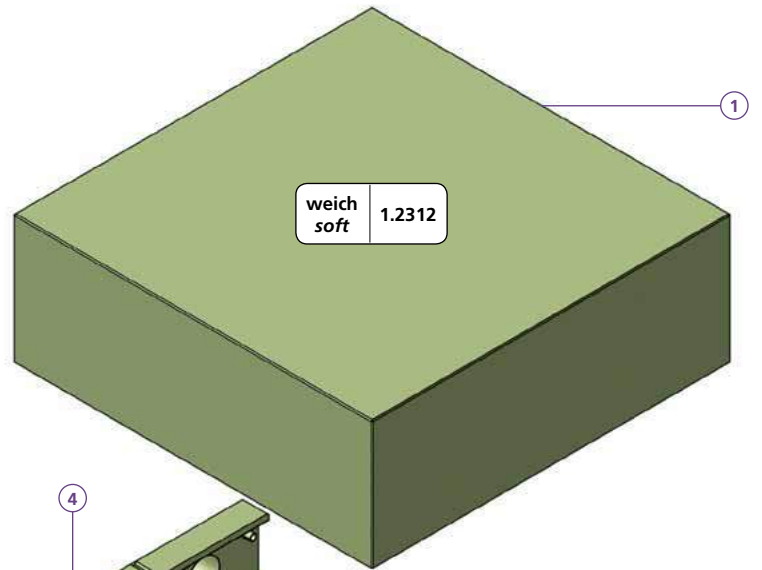
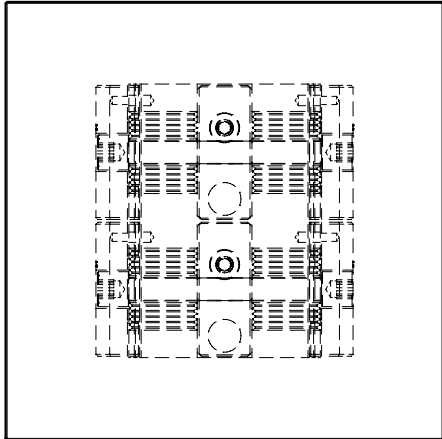
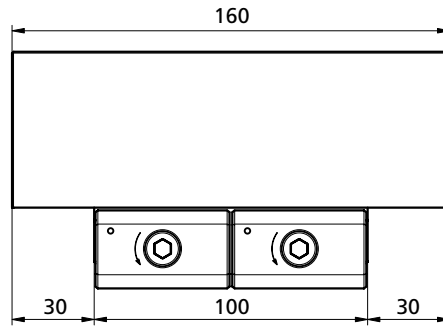
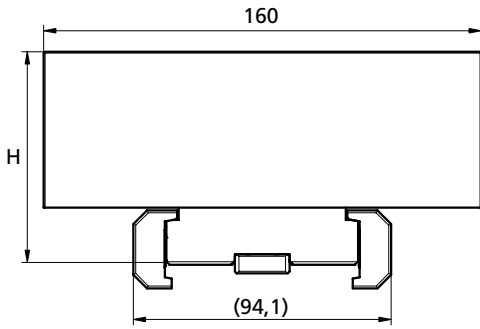

**PTX160-57S**

- ① 1x TH130539
- ③ 2x PCSP50R
- ④ 2x PCSP50L
- ⑤ 2x PCS14
- ⑥ 2x PCGU2049
- ⑦ 2x M6X8ISO7380

H = 57

kg ~9

**PTX160-77S**

- ① 1x TH130723

H = 77

kg ~13

Bestellbeispiel / Ordering example: **PTX160-57S**

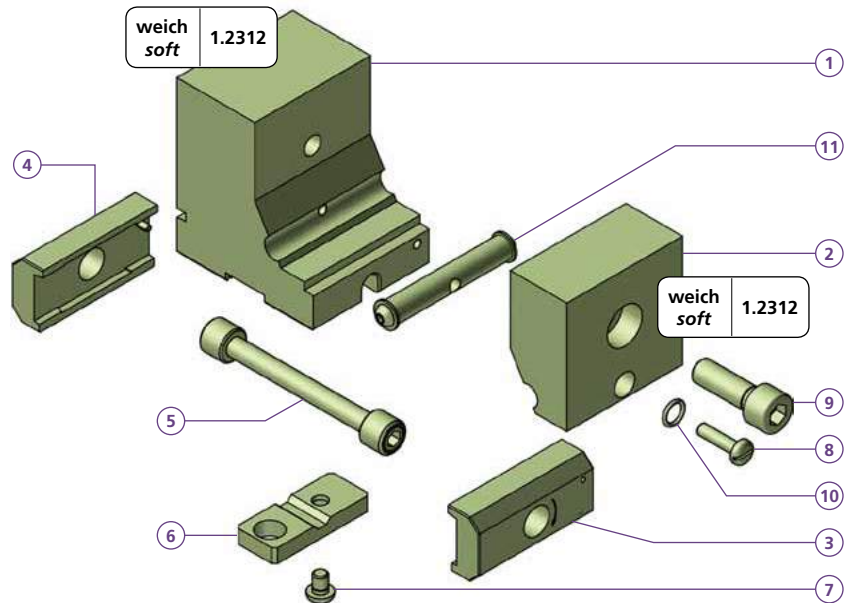
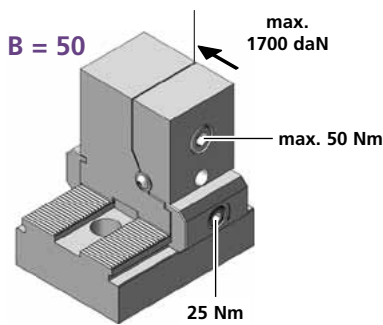
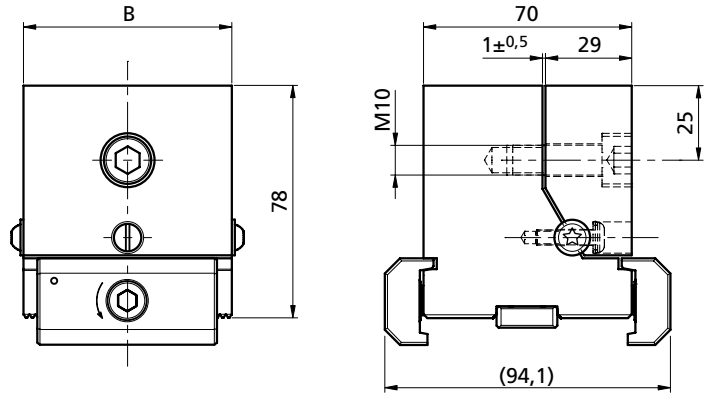
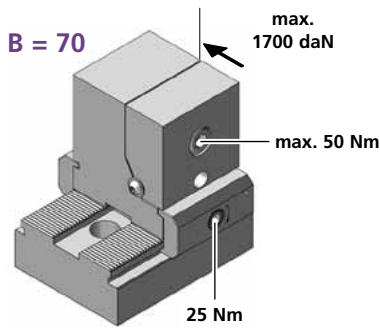

- PS1X70L78ST**
- ① 1x PRS7078AST
  - ② 1x PRS7078SST
  - ③ 1x PCSP60R
  - ④ 1x PCSP60L
  - ⑤ 1x PCS14
  - ⑥ 1x PCGU2049
  - ⑦ 1x M6X8ISO7380
  - ⑧ 1x M5X20BN1362
  - ⑨ 1x M10X30ISO4762
  - ⑩ 1x OR Ø 8x1,5
  - ⑪ 1x PRS7078G
- B** = 70  
**kg** ~3,2

- PS1X50L78ST**
- ① 1x PRS5078AST
  - ② 1x PRS5078SST
  - ③ 1x PCSP50R
  - ④ 1x PCSP50L
  - ⑪ 1x PRS5078G
- B** = 50  
**kg** ~2,3

- PRS70L78ST**
- ① 1x PRS7078AST
  - ② 1x PRS7078SST
  - ⑪ 1x PRS7078G
- B** = 70  
**kg** ~2,8

- PRS50L78ST**
- ① 1x PRS5078AST
  - ② 1x PRS5078SST
  - ⑪ 1x PRS5078G
- B** = 50  
**kg** ~2,0



Drehmoment Torque		Spannkraft Workholding force		
Nm	(lb-ft)	~daN	~(lb)	~t
10	7,4	= 400	880	0,4
20	14,8	= 800	1'760	0,8
30	22,2	= 1'200	2'650	1,2
40	29,6	= 1'600	3'530	1,6

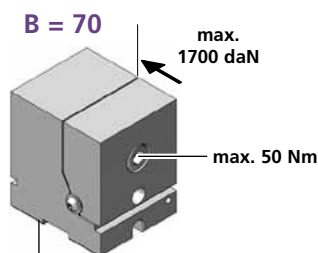

PRS = Rohlingsmodul ohne Spannpratzen  
Blank module side clamp

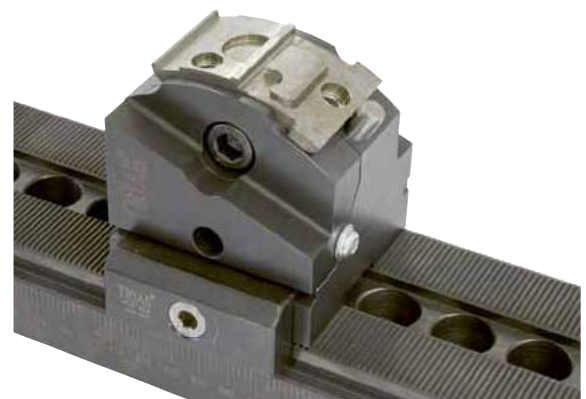

Spannbacken Rohling auf Kundenwunsch angepasst  
Jaw blank machined to customer specification

Bestellbeispiel / Ordering example: **PS1X70L78ST**



# Dreibackenfutter Three jaw chuck

PS3X80L75BSET  
PS3X100L82BSET  
PS3X125L87BSET



powerCLAMP

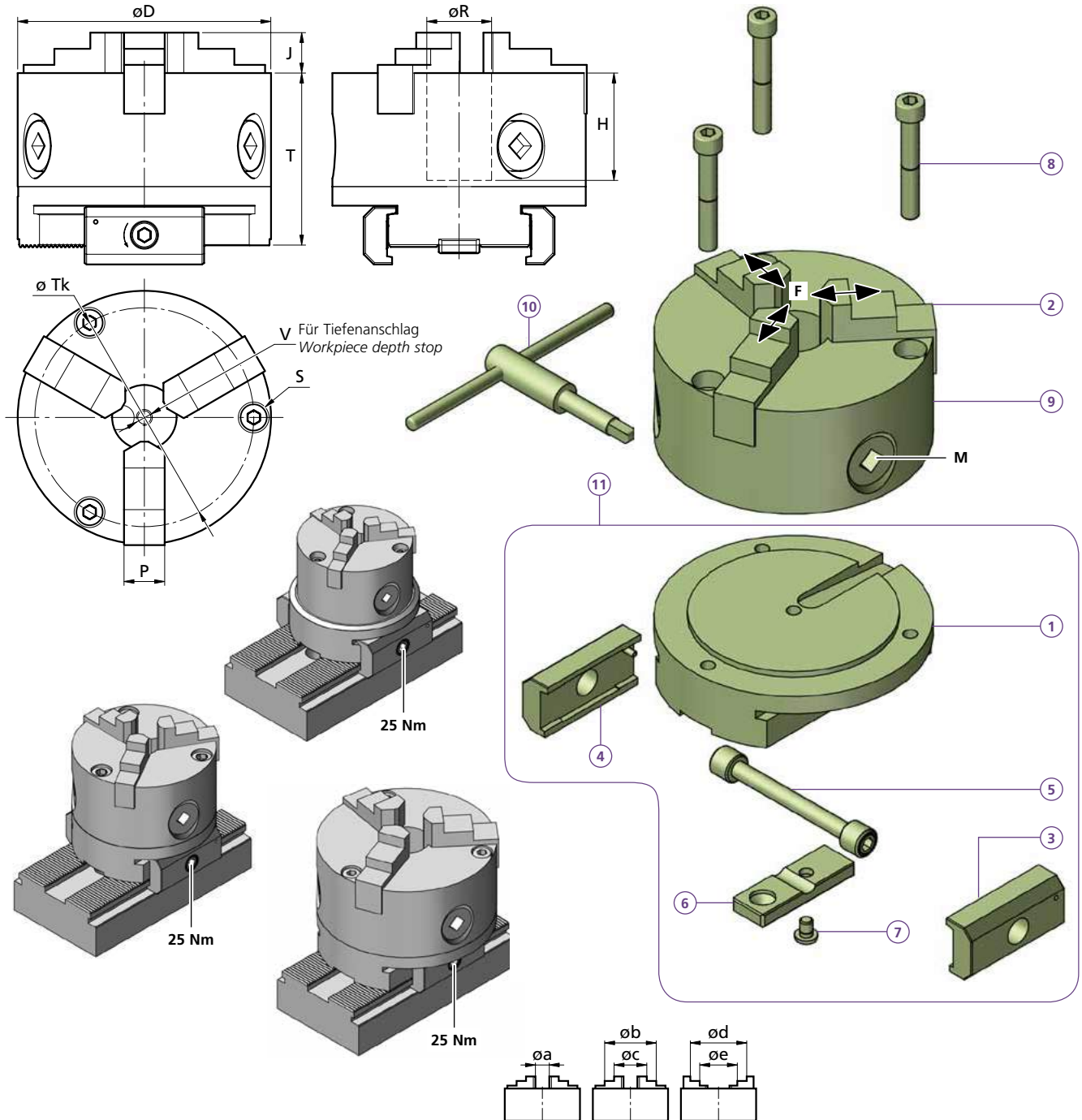

	D	J	T	R	H	P	V	a mm	b mm	c mm	d mm	e mm	M (max.)	F (max.)	$\varnothing T_k$	S
<b>PS3X80L75BSET</b>	80	13	75	15	42,5	10	M6	3...27	48...73	23...48	52...76	27...51	28 Nm	1300 daN	67	M6
<b>PS3X100L82BSET</b>	100	17	82	20	49,5	14	M8	3...39	58...94	24...60	64...100	30...66	38 Nm	1600 daN	83	M8
<b>PS3X125L87BSET</b>	125	19	87	32	55	16	M8	3...49	70...116	30...75	83...125	38...84	55 Nm	2600 daN	108	M8

**PS3X80L75BSET**

1	1x TW090013_01
2	2x 3 Stk. / pcs
3	1x PCSP60R
4	1x PCSP60L
5	1x PCS14
6	1x PCGU2059
7	1x M6X8ISO7380
8	3x M6X45ISO4762
9	1x 243809.0083220
10	1x 243864.0080000
11	PTX80-30

kg ~2,8

**PS3X100L82BSET**

1	1x TW090012_01
2	2x 3 Stk. / pcs
8	3x M8X50ISO4762
9	1x 243809.0103220
10	1x 243864.0100000
11	PTX100-30

kg ~4,3

**PS3X125L87BSET**

1	1x TW080027_01
2	2x 3 Stk. / pcs
8	3x M8X55ISO4762
9	1x 243809.0123220
10	1x 243864.0120000
11	PTX125-29

kg ~6,3

<p>80</p> <p>100</p> <p>125</p>	<p>243849.0083200</p> <p>243849.0103200</p> <p>243849.0123200</p>	<p>243850.0083200</p> <p>243850.0103200</p> <p>243850.0123200</p>	<p>*243834.0083300</p> <p>*243834.0103300</p> <p>*243834.0123300</p>
---------------------------------	---	---	--

Bestellbeispiel / Ordering example: PS3X125L87BSET

Separat bestellen / Separate order

PS1X50N62-ER32

Ø 1 - 22 mm

PS1X50N100-ER32

Ø 1 - 22 mm

PS1X63N100-ER40

Ø 2 - 30 mm



powerCLAMP

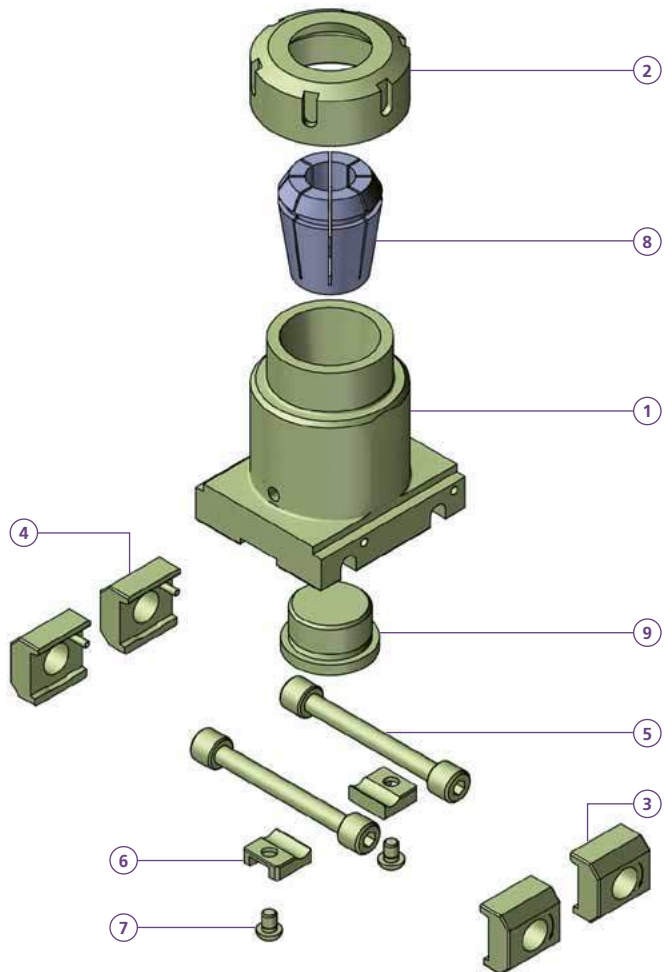
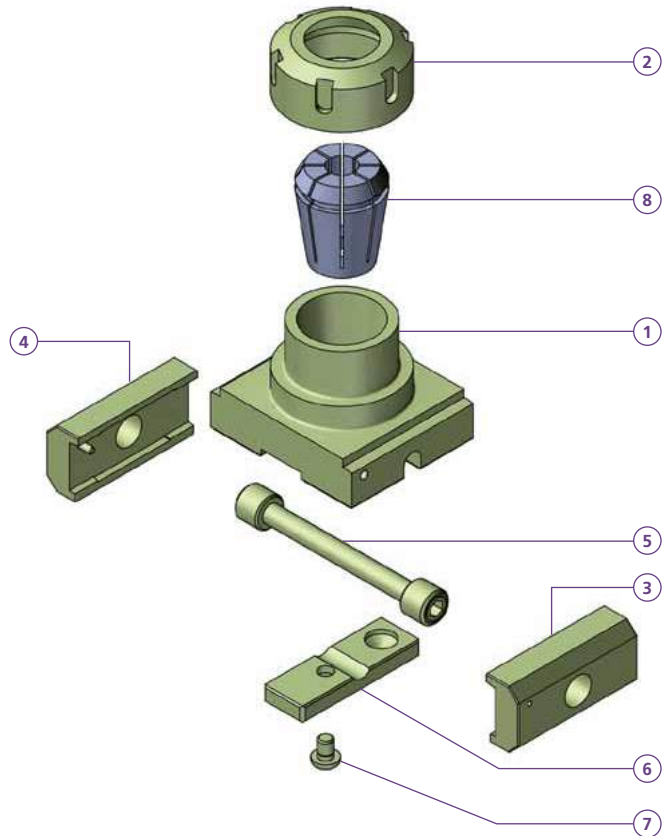
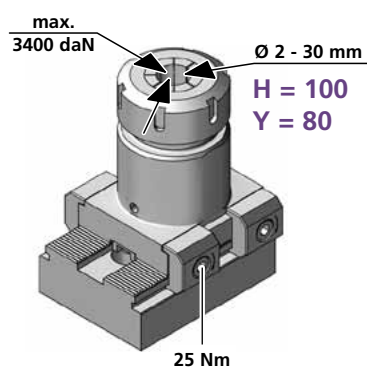
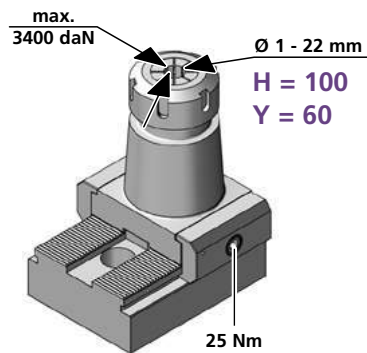
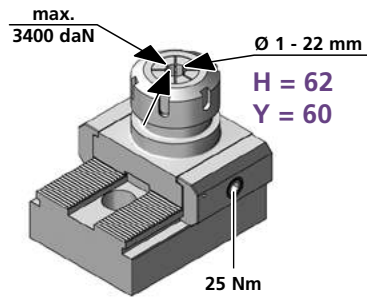
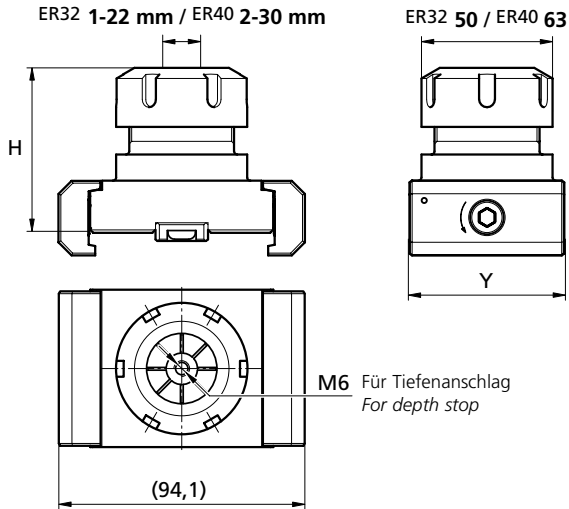

**PS1X50N62-ER32**

1	1x TW090089-01
2	1x ER32
3	1x PCSP60R
4	1x PCSP60L
5	1x PCS14
6	1x PCGU2059
7	1x M6X8ISO7380
8	1x ER/ESX32

H = 62  
Y = 60  
kg ~1,3

**PS1X50N100-ER32**

1	1x TW090047-01
---	----------------

H = 100  
Y = 60  
kg ~2,2

**PS1X63N100-ER40**

1	1x TW110026-01
2	1x ER40
3	2x PCSP30R
4	2x PCSP30L
5	2x PCS14
6	2x PCGU2020
7	2x M6X8ISO7380
8	1x ER/ESX40
9	1x M33x2 DIN908

H = 100  
Y = 80  
kg ~2,3

Bestellbeispiel / Ordering example: 1x PS1X 50N62 -ER32 & 1x ER32

Separat bestellen / Separate order

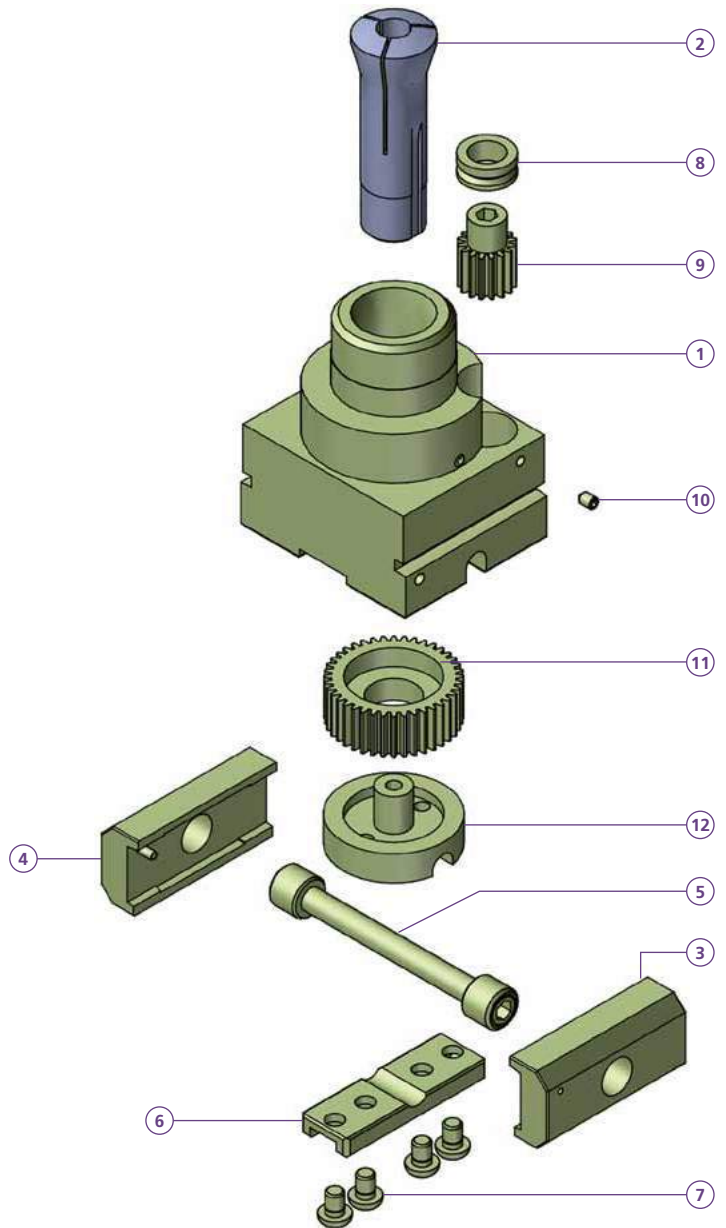
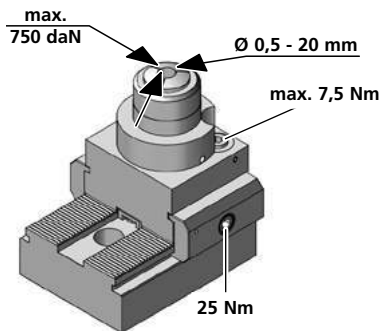
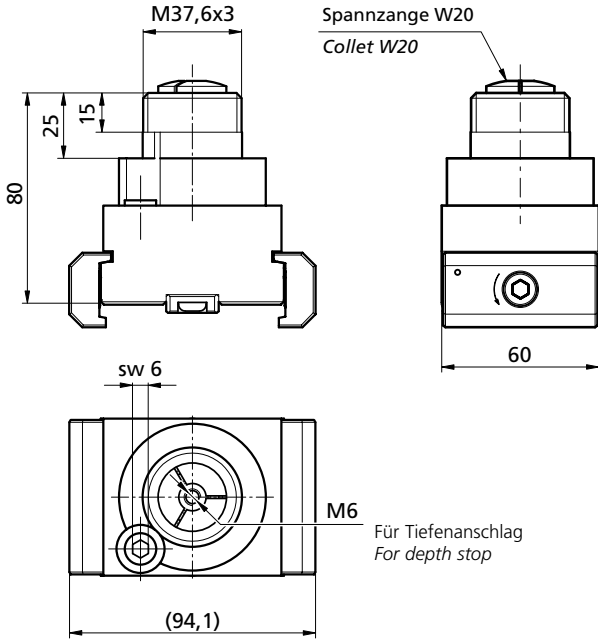

PS1X68N80-W20	
1	1x TW080018-01
2	1x W20
3	1x PCSP60R
4	1x PCSP60L
5	1x PCS14
6	1x PCGUW20
7	4x M6X8ISO7380
8	1x PCD1808
9	1x PCRZ1825
10	1x M4X6ISO4027
11	1x PCZM4215
12	1x PCABD4221
kg	~1,8

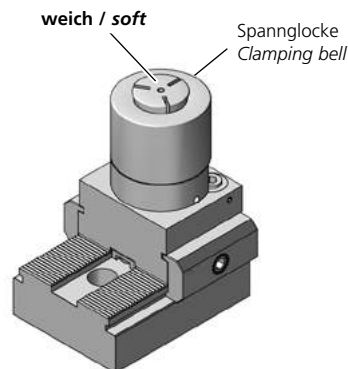

Bestellbeispiel / Ordering example: 1x PS1X68N80-W20 & 1x W20





**PS1F-KLD1**  
**PS1F-KLD1NS**

powerCLAMP

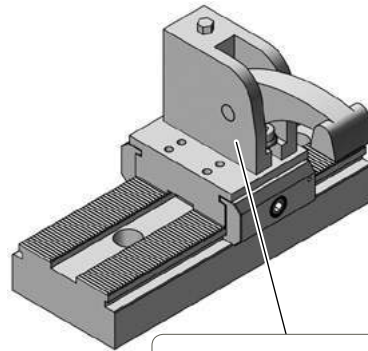
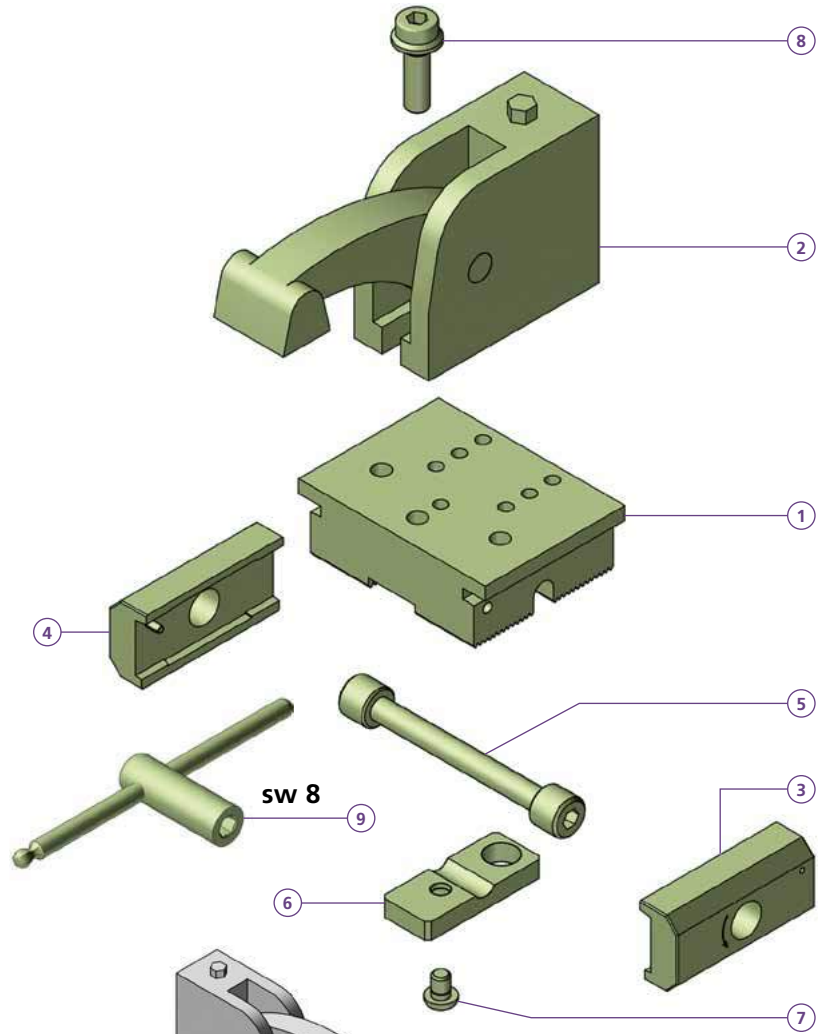
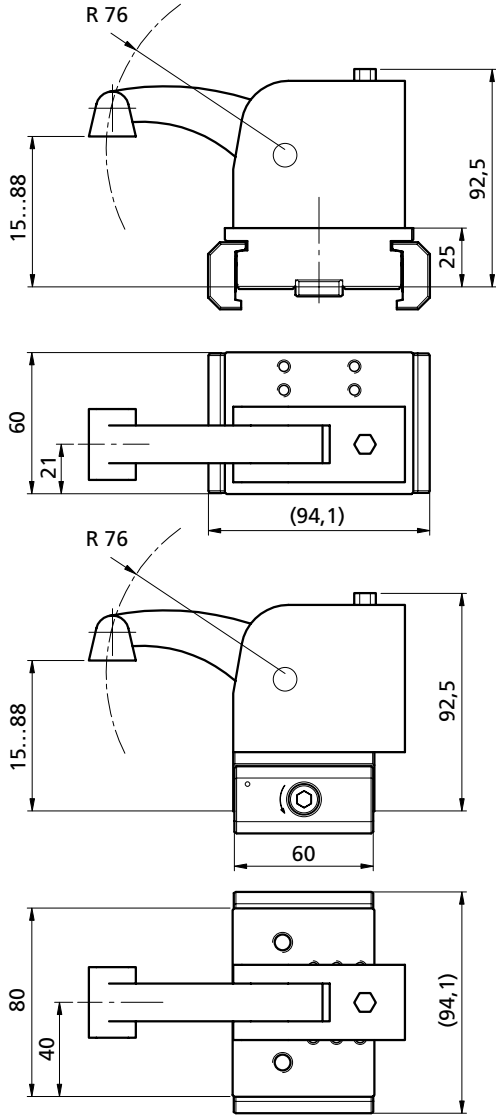

Spanner quer montiert  
Clamp mounted transversely

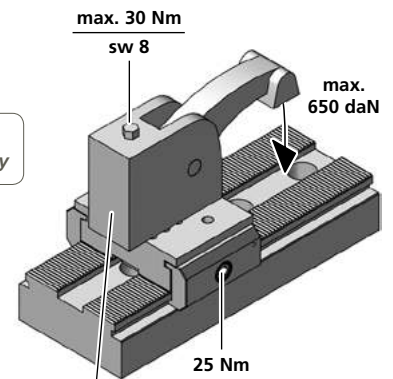

Spanner längs montiert  
Clamp mounted longitudinally



NS = Trägermodul freie Positionierung ohne Verzahnung  
Carrier module without positioning serration for free positioning

PS1F-KLD1	
1	1x PCTMV1F
2	1x 07-020
3	1x PCSP60R
4	1x PCSP60L
5	1x PCS14
6	1x PCGU2049
7	1x M6X8ISO7380
8	1x M8x25 TW080012-02
9	1x 07-180
kg	~2,1
PS1F-KLD1NS	
2	1x PCTMV1FNS
kg	~2,1

Bestellbeispiel / Ordering example: **PS1F-KLD1NS**

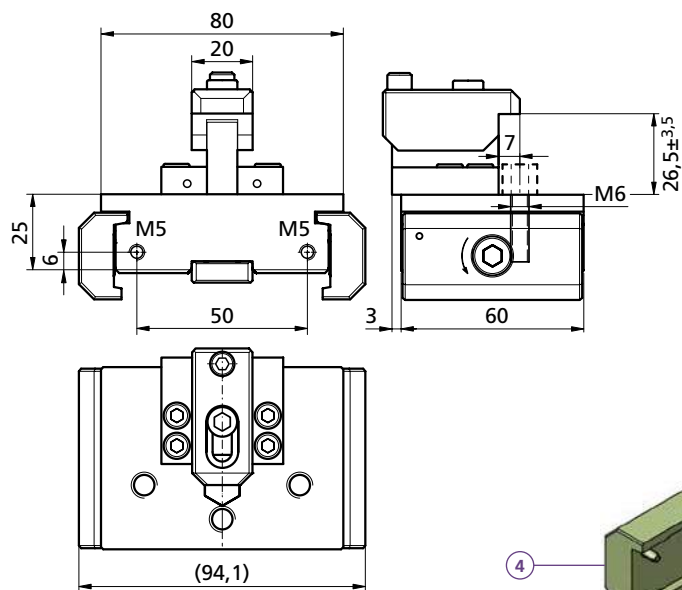

microCLAMP p. 177

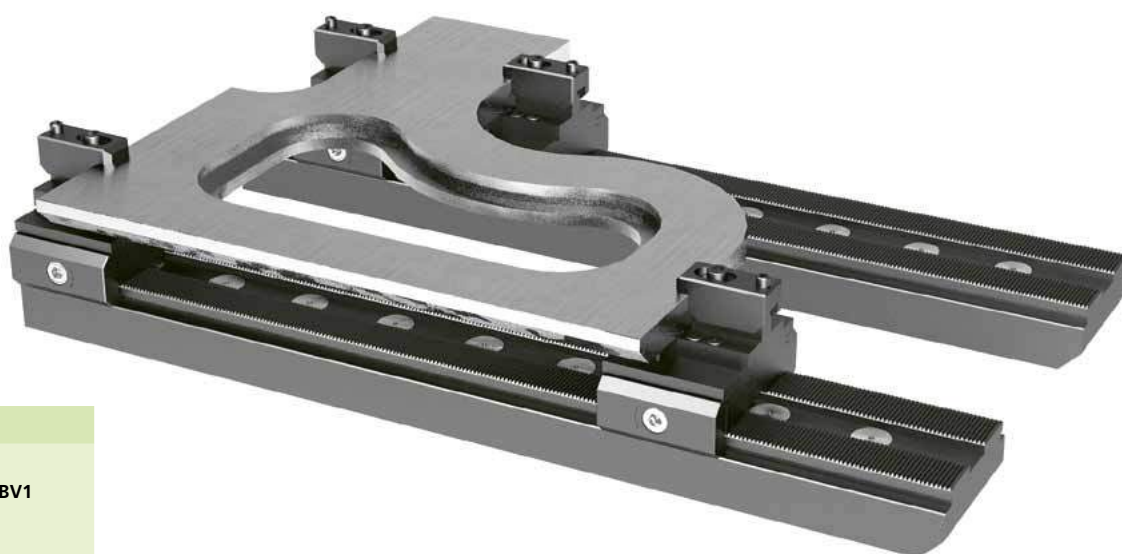
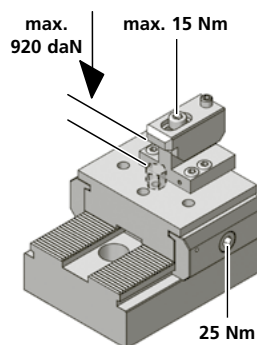
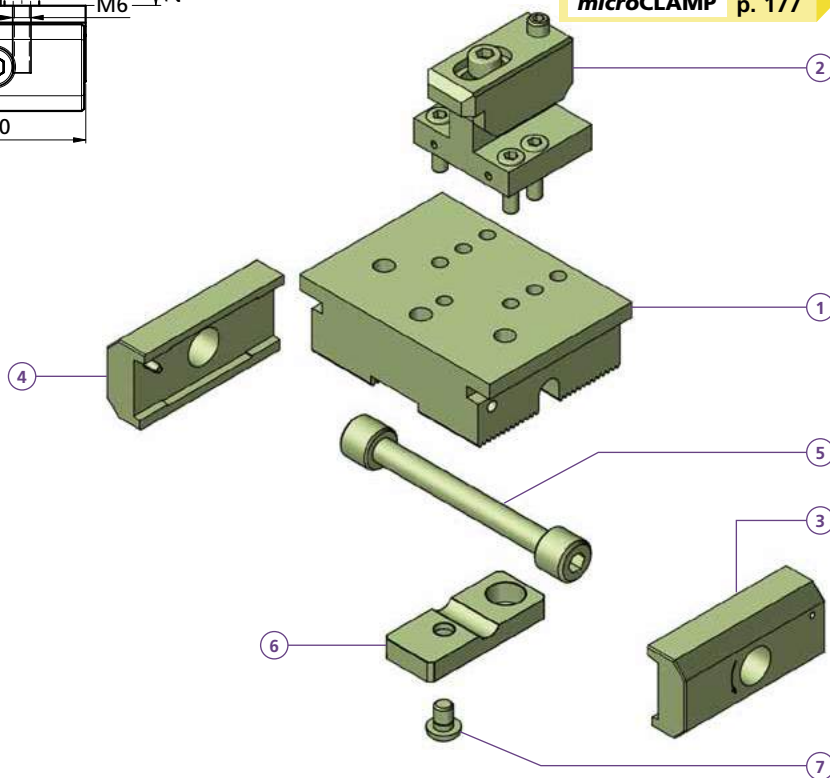

**PS1F20L35BV1**

- ① 1x PCTMV1F
- ② 1x MV1F20L35BV1
- ③ 1x PCSP60R
- ④ 1x PCSP60L
- ⑤ 1x PCS14
- ⑥ 1x PCGU2049
- ⑦ 1x M6X8ISO7380

kg ~1,4

**PS1F20L35BV1NS**

- ② 1x PCTMV1FNS

kg ~1,4

NS = Trägermodul freie Positionierung ohne Verzahnung  
Carrier module without positioning serration for free positioning

Bestellbeispiel / Ordering example: PS1F20L35BV1



# Magnetspannplatte

## Magnetic chuck

PS1X150L60-250MAG11

powerCLAMP

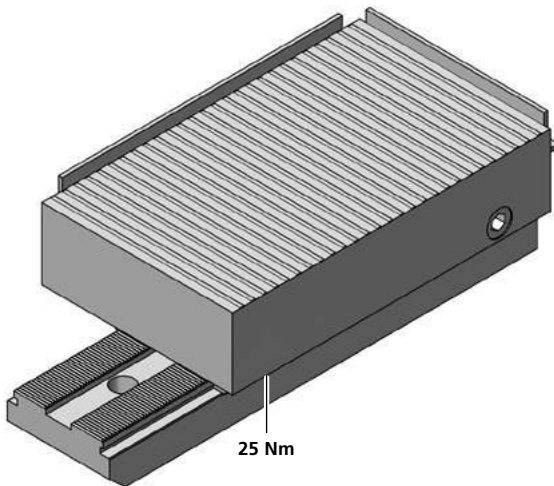
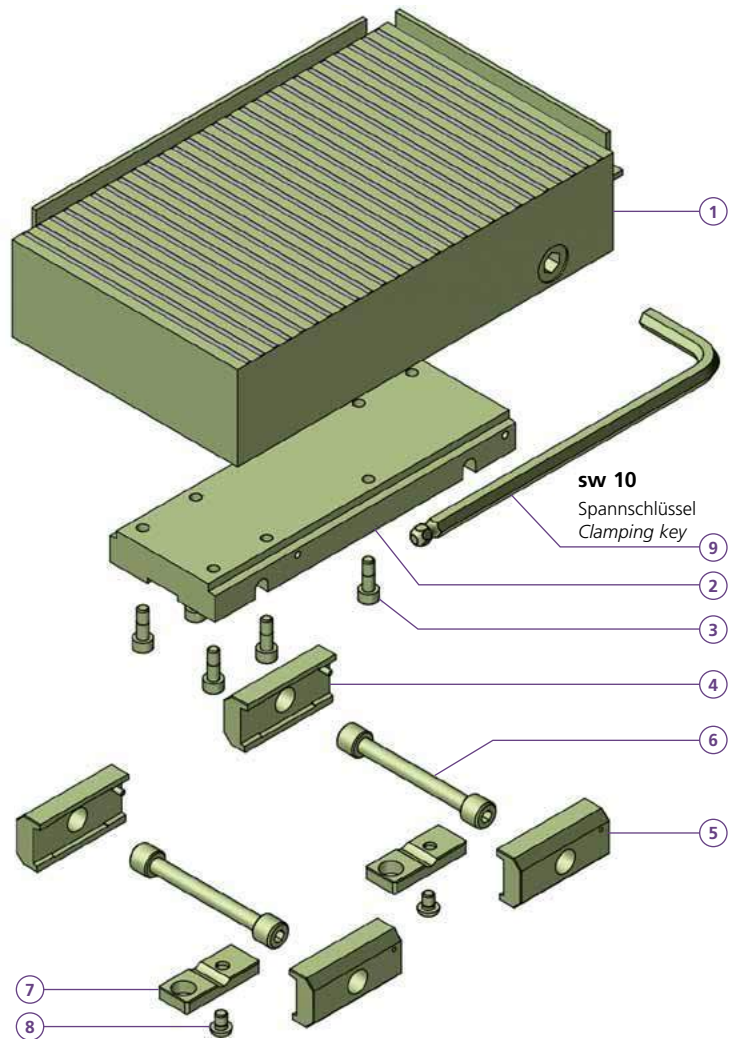
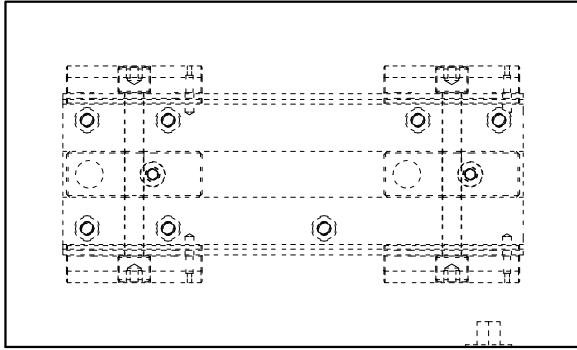
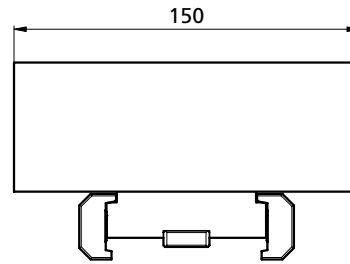
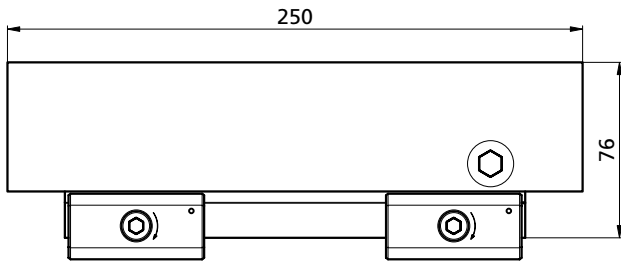

### PS1X150L60-250MAG11

- ① 1x XNeomill 250x150
  - ② 1x TL110010-01
  - ③ 7x MS60
  - ④ 2x PCSP60L
  - ⑤ 2x PCSP60R
  - ⑥ 2x PCS14
  - ⑦ 2x PCGU2049
  - ⑧ 2x M6X8ISO7380
  - ⑨ 1x ISL10 DIN 911L
- kg ~19,5

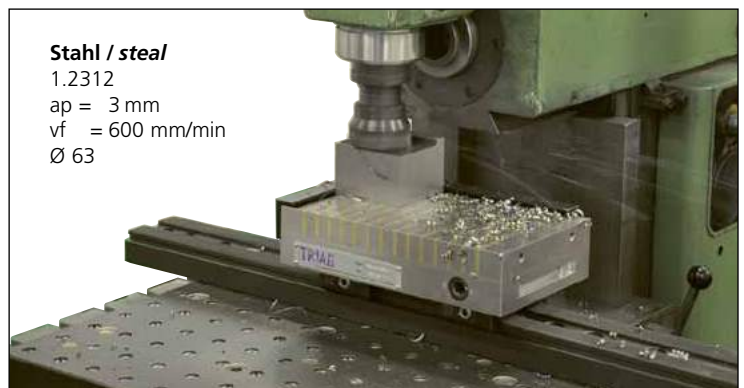

**Stahl / steel**  
 1.2312  
 $a_p = 3 \text{ mm}$   
 $v_f = 600 \text{ mm/min}$   
 $\varnothing 63$

**max. Haltekraft / max. holding force = 120 N/cm<sup>2</sup>**

- Werkstücke ab 26 mm Länge und 6 mm Stärke werden optimal gespannt
- Workpieces from 26 mm length and 6mm thickness will be optimally hold

Bestellbeispiel / Ordering example: PS1X150L60-250MAG11





# Vakuum-Modul

## Vacuum module

## PS1X150L60-VAC

## powerCLAMP

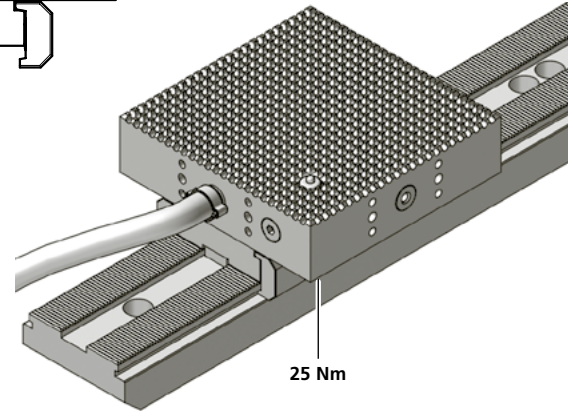
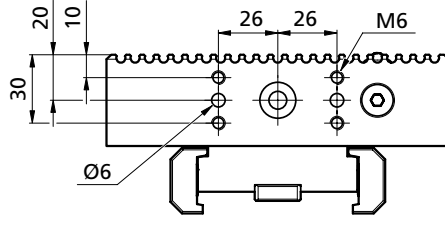
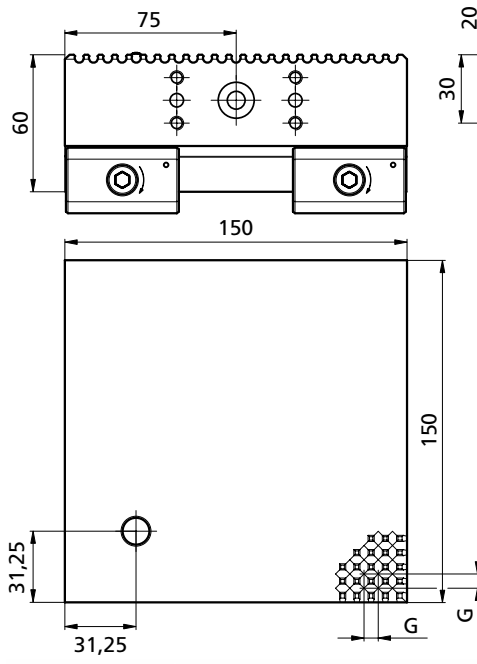

**trivaCLAMP** p. 318

Mehr Informationen siehe Vacuum  
For more information check the vacuum workholding

Bestellbeispiel / Ordering example: PS1X150L60-VAC

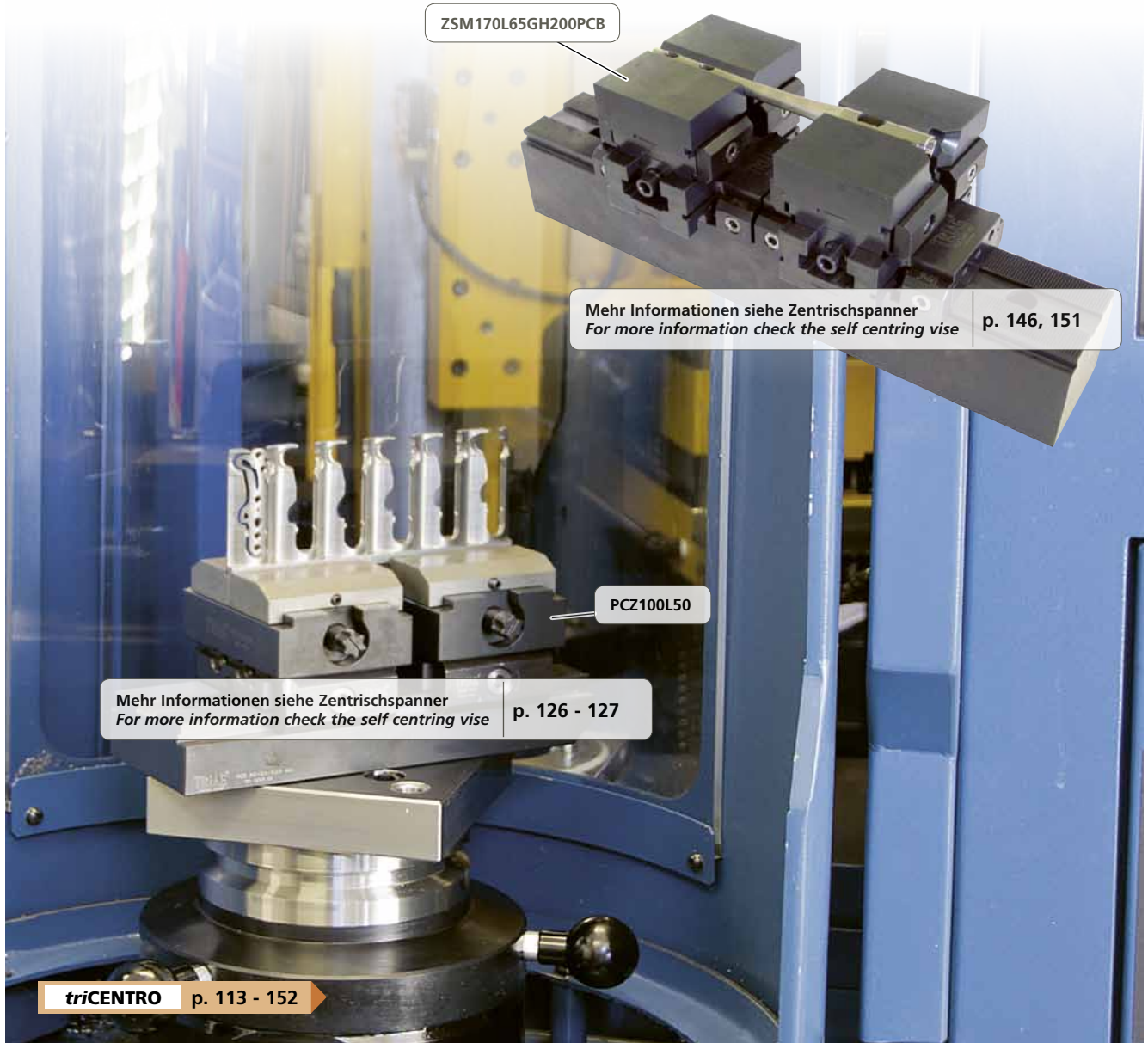

ZSM170L65GH200PCB

Mehr Informationen siehe Zentrischspanner  
For more information check the self centring vise p. 146, 151

PCZ100L50

Mehr Informationen siehe Zentrischspanner  
For more information check the self centring vise p. 126 - 127

**triCENTRO** p. 113 - 152

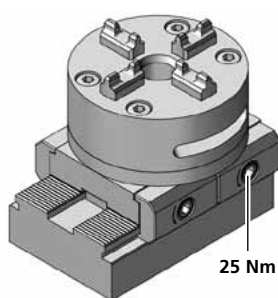
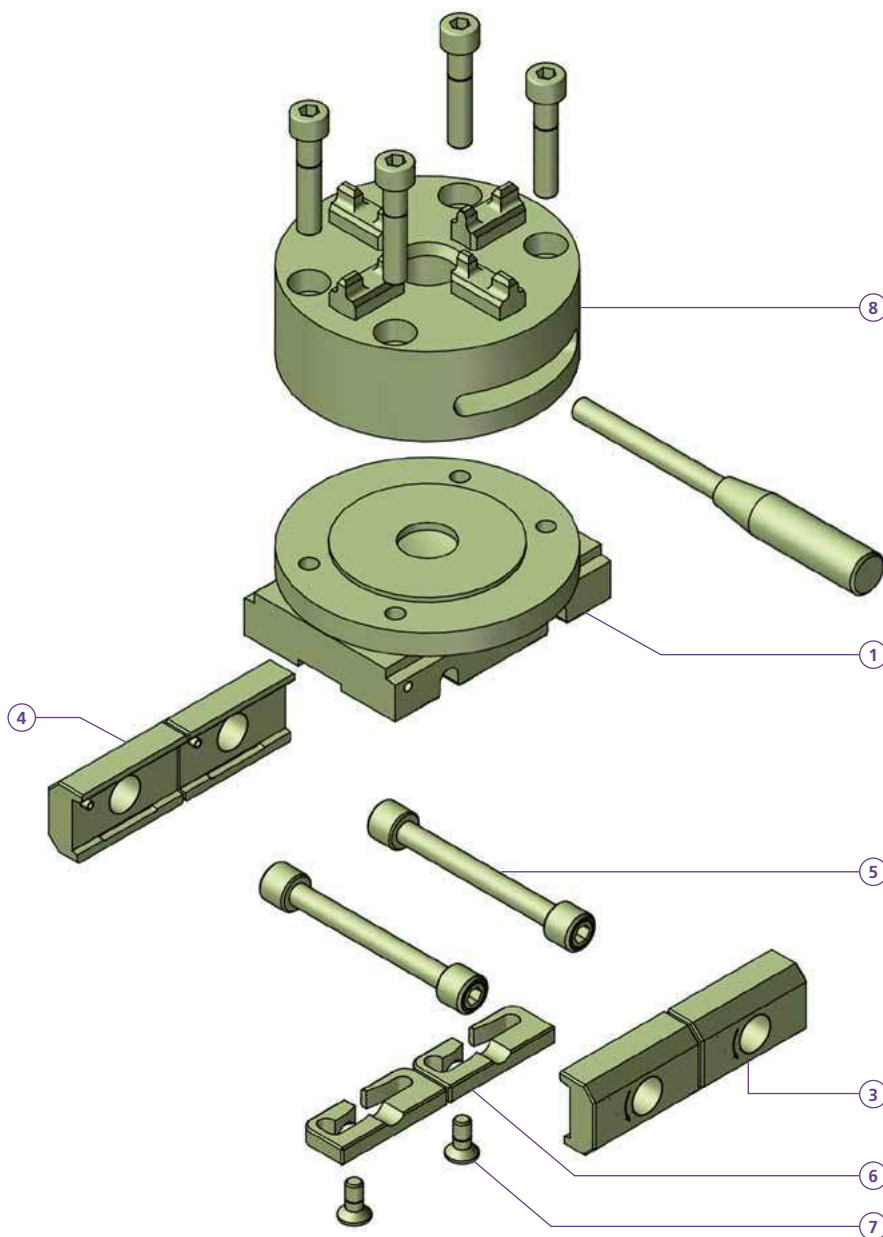
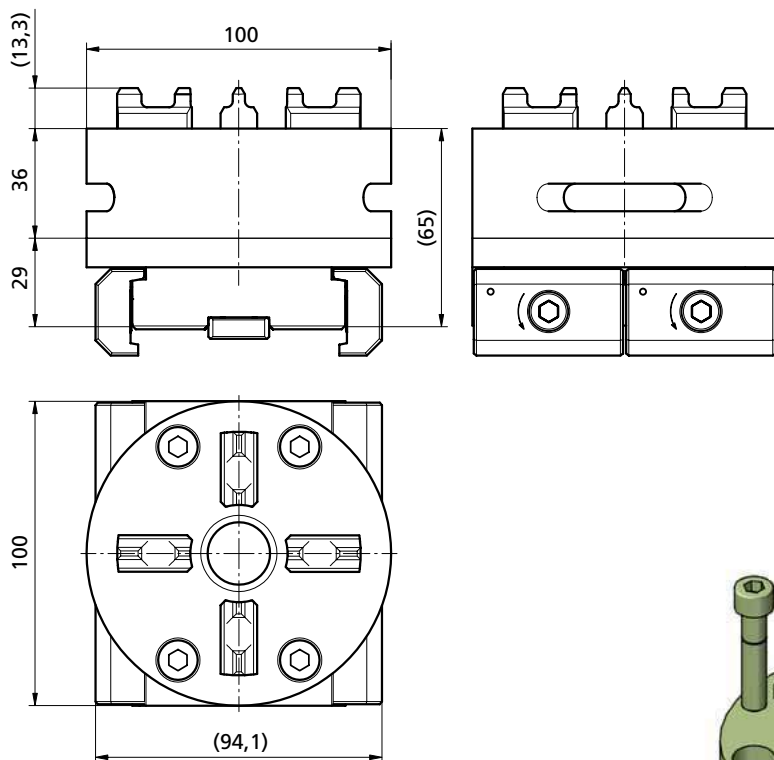

**PS1X100-65ER-036345**

- 1 1x PTX100-29
  - 3 2x PCSP50L
  - 4 2x PCSP50R
  - 5 2x PCS14
  - 6 2x PCGU2049F
  - 7 2x M6X14ISO10642
  - 8 1x ER-036345
- kg ~4,0

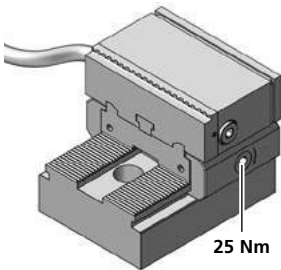
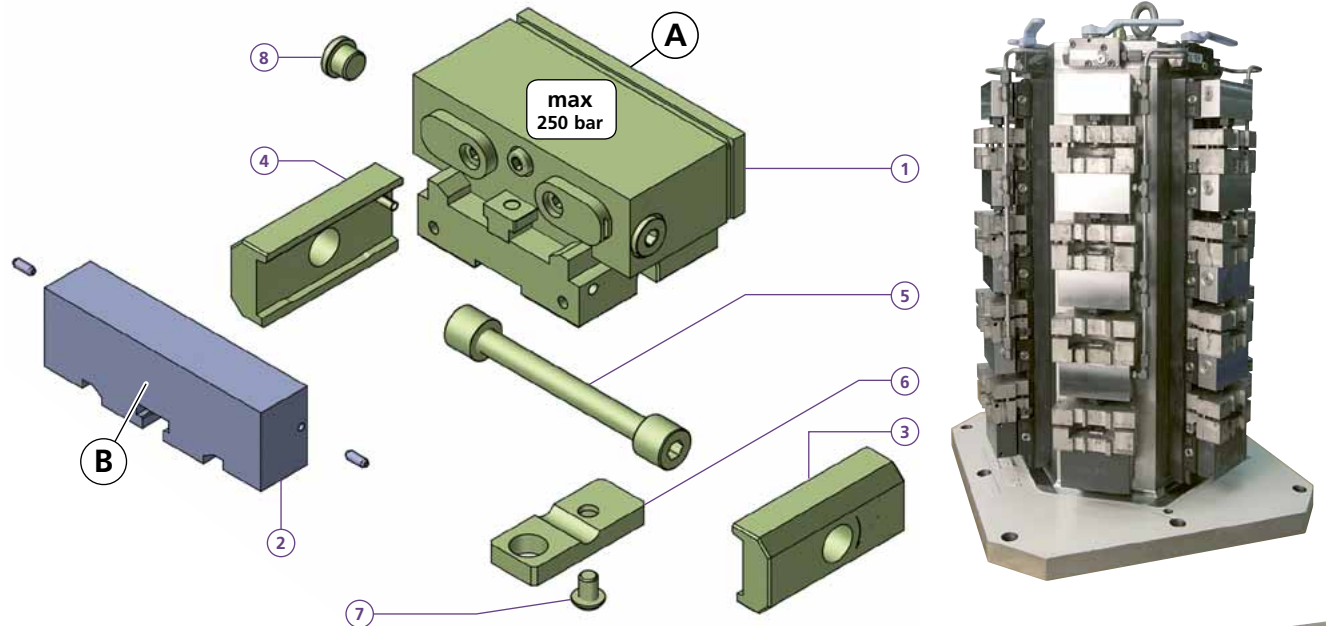
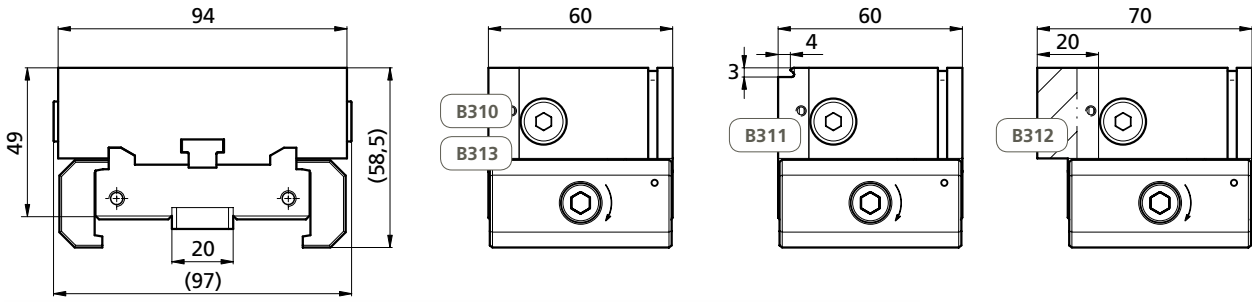

Ölvolumen / Oil volume	
Spannen / Clamping	
8 cm <sup>3</sup>	

5 mm Hub / Stroke			
bar	~daN	~(lb)	~t
100	= 960	2116	0,96
150	= 1'440	3175	1,44
200	= 1'920	4233	1,92
250	= 2'400	5291	2,4

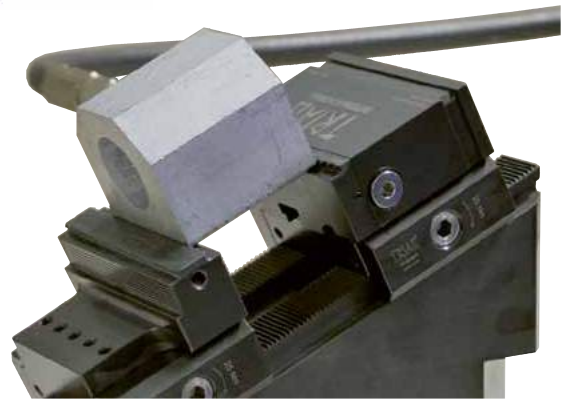

Bestellbeispiel / Ordering example: PSH1X94L49-310 & 1 x B310

<b>B310</b>	<b>B311</b>	<b>B312</b>	<b>B313</b>	
<b>C</b> 94	94	94	94	
<b>H</b> 31,5	31,5	31,5	31,5	
<b>L</b> 10	10	20	10	
<b>i</b> HV700	57HRC	*	HV700	
x0,2mm			x0,2mm	
<b>kg</b> ~0,18	~0,17	~0,39	~0,17	

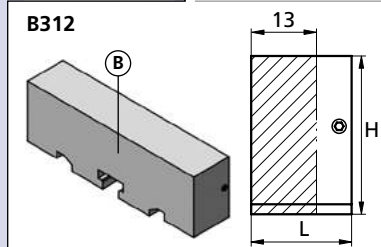
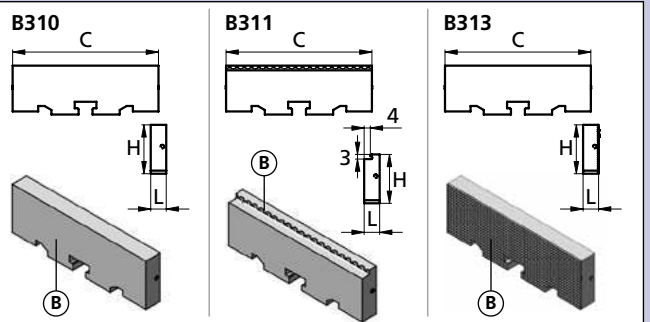

**Zum Erstellen Ihrer individuellen Formbacke:**

Schnittzeichnung zum Ermitteln der maximalen Bearbeitungsprofiltiefe

**If a dedicated jaw is being machined:**  
Sectional drawing to determine the maximum machining depth

PSH1X94L49-310

- 1 1x ZF191349
- 2 1x \_\_\_\_\_
- 3 1x PCSP60R
- 4 1x PCSP60L
- 5 1x PCS14
- 6 1x PCGU2049
- 7 1x M6X815O7380
- 8 2x TN100014
- kg ~1,94

\* = weich / soft (1.7225 Vergütungsstahl / Tempering steel)





**Universalbacke / Universal jaw**

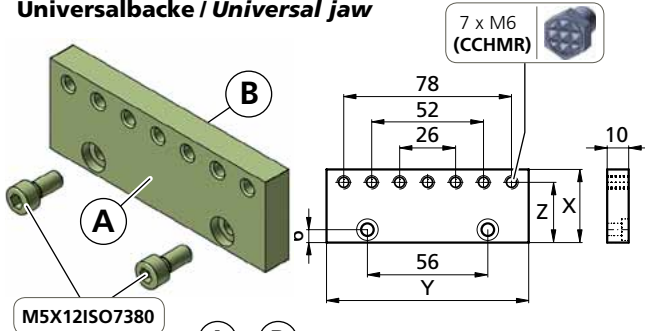

	A	B	X	Y	Z	i	kg
PC9434			34	94	28	HV700 x 0,2mm	~0,23
PC12549			49	123,8	43	HV700 x 0,2mm	~0,46

**weiche Backe / soft jaw**

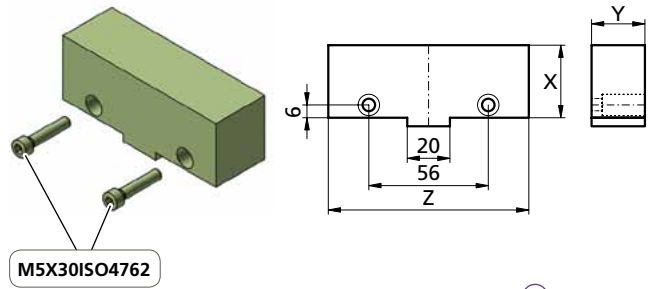

	X	Y	Z	i	kg
*PC943425W	34	25	94		~0,64
*PC943430W	34	30	94	1.0570	~0,77
*PC944930W	49	30	94		~1,10
*PC1254930W	49	30	125		~1,46

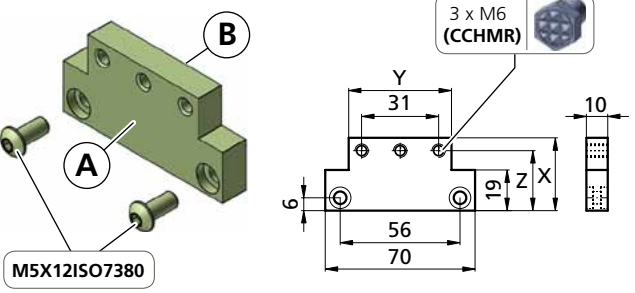

	A	B	X	Y	Z	i	kg
PC4349			49	43	43	HV700 x 0,2mm	~0,21
PC4834			34	48	28	HV700 x 0,2mm	~0,17

**Backe mit 2 Pendeldruckstücken  
Jaw with 2 swiveling balls**

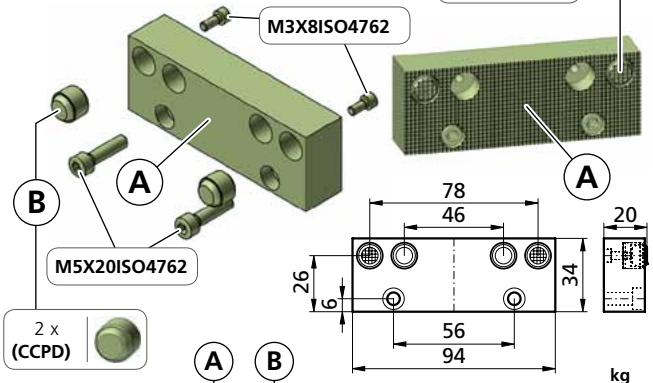

	A	B	kg
PC9460			~0,45
PC9460R			~0,45

**Prägebacke / Stamping jaw**

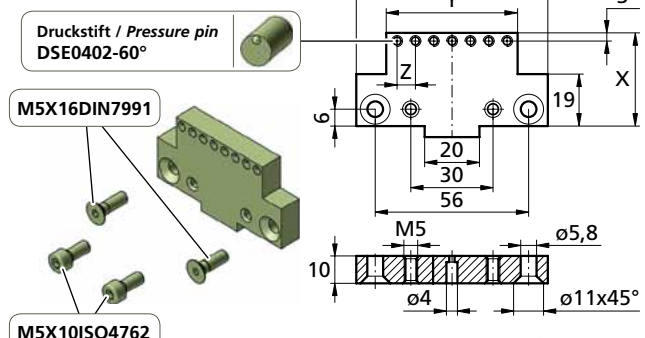

	X	Y	Z	i	kg
PC4834DS	34	48	6 x 6,7 = 40,2		~0,17
PC4349DS	49	43	6 x 5,83 = 35	HV700 x 0,2mm	~0,22
PC4849DS	49	48	6 x 6,7 = 40,2		~0,23

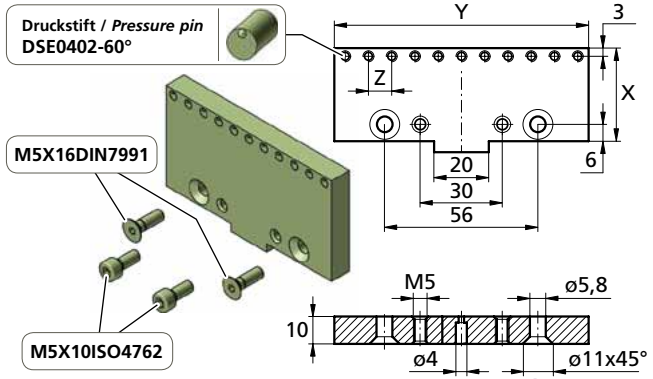

	X	Y	Z	i	kg
PC9434DS	34	94	10 x 8,5 = 85		~0,27
PC9449DS	49	94	10 x 8,5 = 85	HV700 x 0,2mm	~0,38
PC12549DS	49	124	13 x 8,5 = 110,5		~0,49

**Prismbacke / Prismatic jaw**

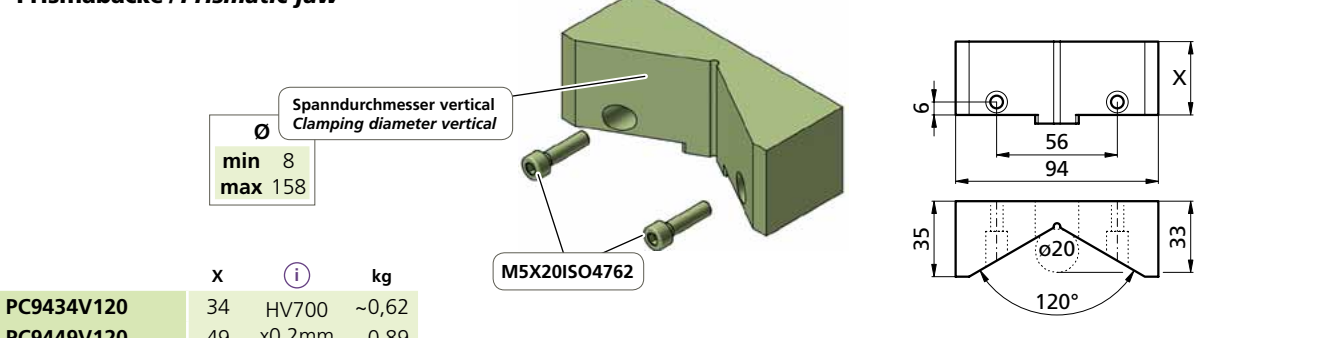

	X	i	kg
PC9434V120	34	HV700	~0,62
PC9449V120	49	x0,2mm	~0,89

\* = weicher Stahl / soft steel

Bestellbeispiel / Ordering example: PC9434

Separat bestellen / Separate order



**Prismabacke / Prismatic jaw**

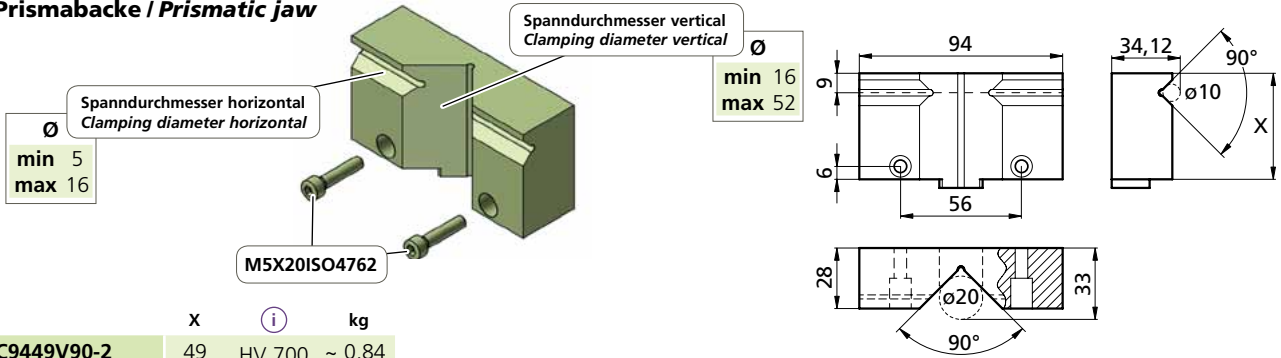

	x	i	kg
PC9449V90-2	49	HV 700	~ 0,84
PC9434V90-2	34	x0,2mm	~ 0,58

**Universalbacke / Universal jaw**

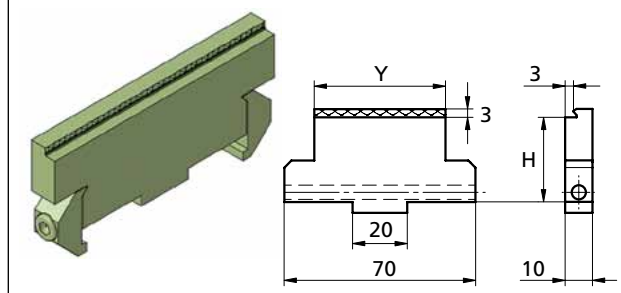
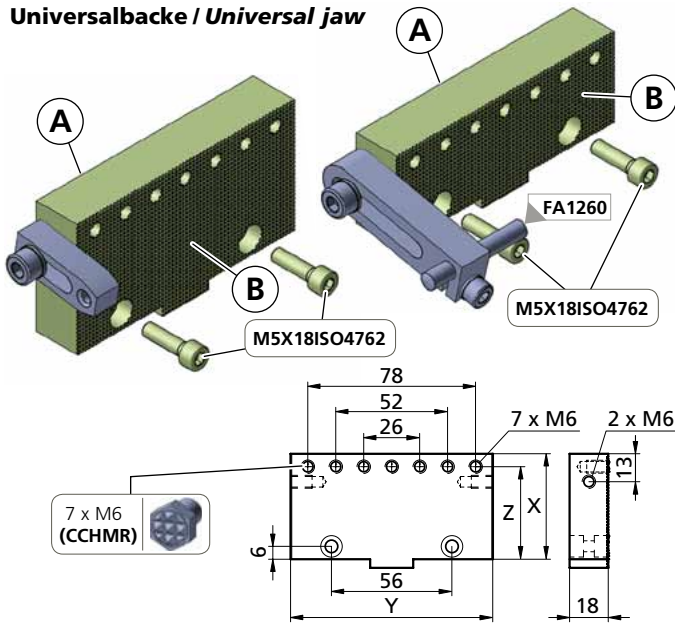

	Y	H	i	kg
PC48-34PRG	48	31		~ 0,19
PC48-49PRG	48	46	57HRC	~ 0,25
PC94-34PRG	94	31		~ 0,36
PC94-49PRG	94	46		~ 0,48

	A	B	x	Y	Z	i	kg
PC9434RF			34	94	28	HV 700	~0,24
PC9449RF			49	94	43	x 0,2mm	~0,35

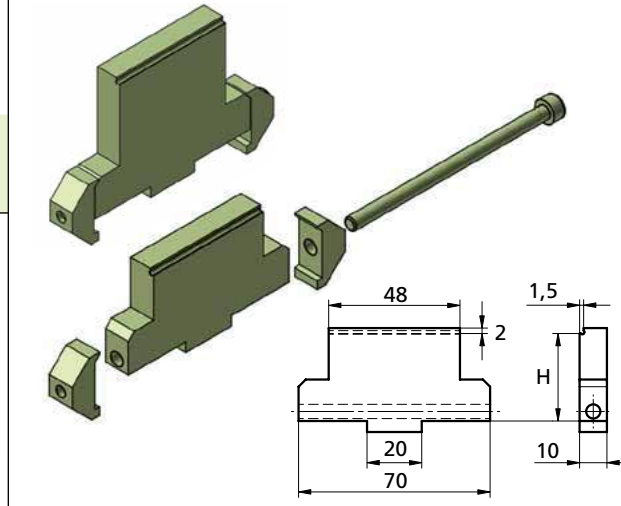
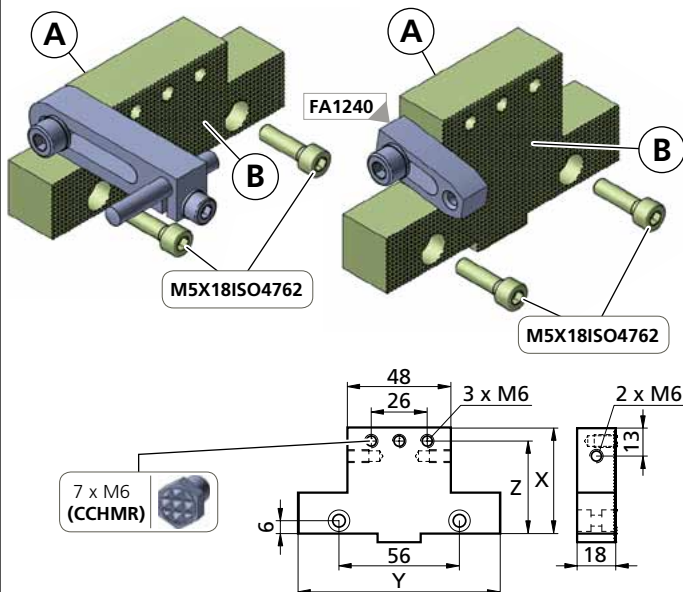

	H	i	kg
PC4834-15	32	HV700 x 0,2mm	~ 0,19
PC4849-15	47		~ 0,25

	A	B	x	Y	Z	i	kg
PC4834RF			34	94	28	HV 700	~0,33
PC4849RF			49	94	43	x 0,2mm	~0,43

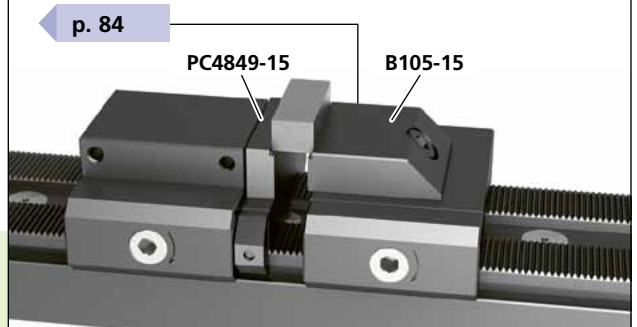

Bestellbeispiel / Ordering example: PC 9434 RF & 1 x FA1240

Separat bestellen / Separate order



**Von Niederzug zu Linear!**  
**From pull down jaws to linear stroke!**

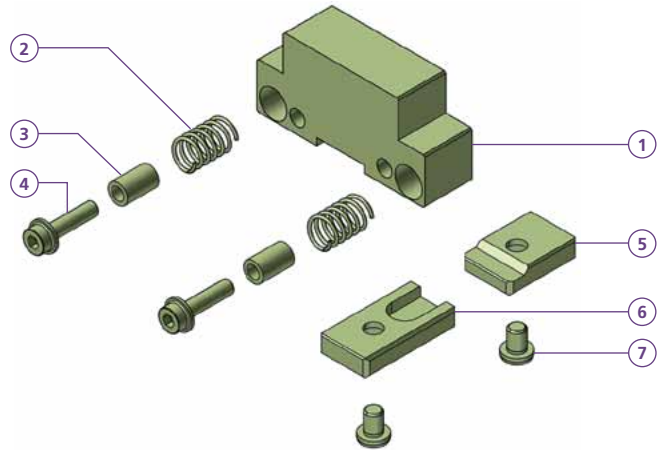
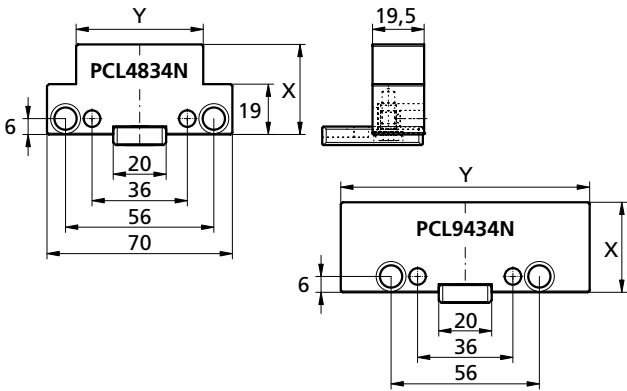

**PCL4349N**

- 1 1x TF140697
- 2 2x FED10175
- 3 2x PCD0813
- 4 2x M5X20BN1392
- 5 1x PCGU2028
- 6 1x PCGU2030LB
- 7 2x M6X8ISO7380

X = 49  
Y = 43  
kg ~0,43

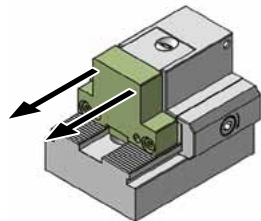

**PCL4834N**

- 1 1x TF140698
- 2 2x FED10175
- 3 2x PCD0813
- 4 2x M5X20BN1392
- 5 1x PCGU2028
- 6 1x PCGU2030LB
- 7 2x M6X8ISO7380
- 8 1x M10X22ISO4762

X = 48  
Y = 48  
kg ~0,35

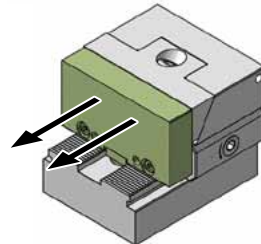

**PCL9449N**

- 1 1x TF140700

X = 49  
Y = 94  
kg ~0,74

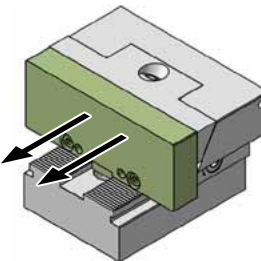

**PCL12549N**

- 1 1x T00317

X = 49  
Y = 125  
kg ~0,97

**PCL9434N**

- 1 1x TF140699

X = 34  
Y = 94  
kg ~0,52

Die Spannschraube 8 der 34 mm hohen Spannmodule müssen durch eine kürzere Schraube ausgetauscht werden!  
*The clamping screws 8 of the 34 mm high clamping modules must be replaced by a shorter screw!*

Bestellbeispiel / Ordering example: **PCL4834N**

**Montagehilfe und Ersatzteile für Linearbacken**  
**Assembling tool for linear jaws and spare parts**

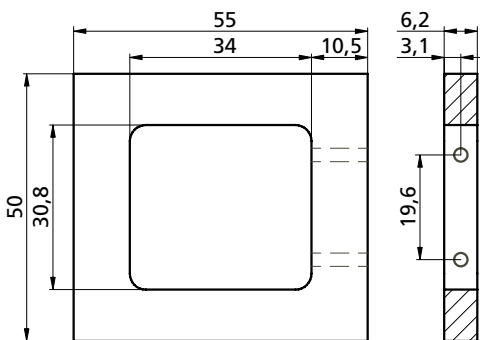

**BL-SET**

- 1 2x TN100823
- 2 1x TK160609
- 3 2x PCRB0516
- 4 2x TN100614
- 5 1x —————

kg ~0,08

p. 84

Alle Linearbacken  
All linear jaws

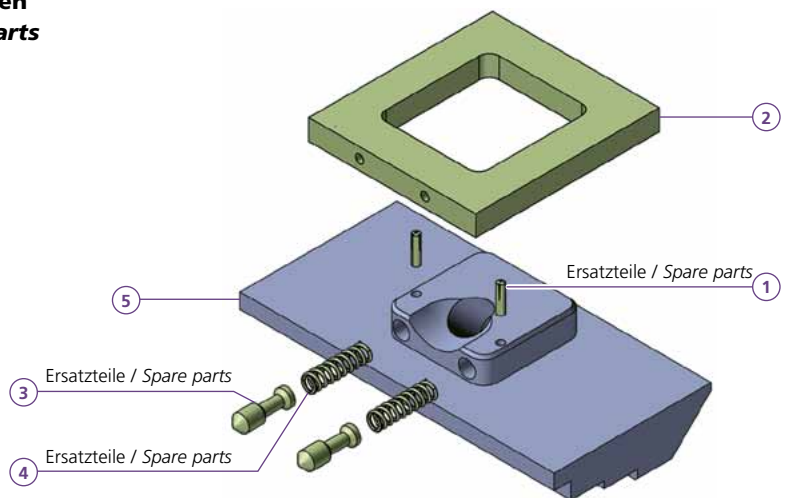

Montageanleitung siehe Video  
Assembly instructions see video



Separat bestellen / Separate order





Click-Flex

PCFX30

PCFX50

PCFX35

PCFX70

powerCLAMP

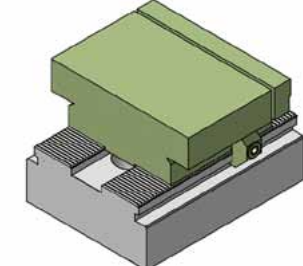
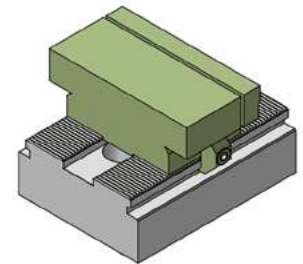
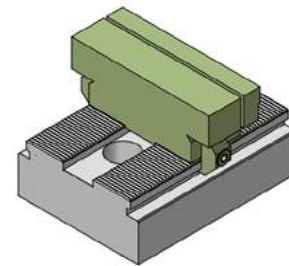
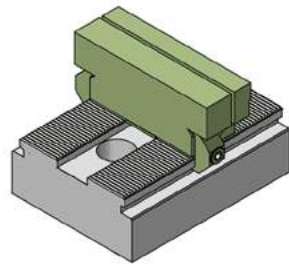
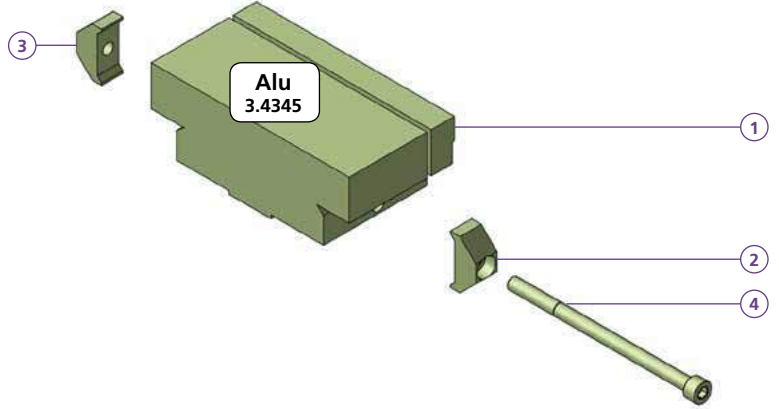
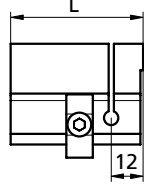
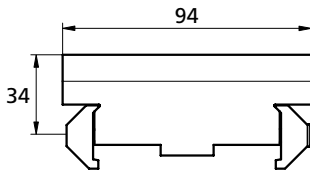

**PCFX30**

- ① 1x TF140702
  - ② 1x PCSP10B
  - ③ 1x PCSP10G
  - ④ 1x M5X85ISO4762
- L = 30  
kg ~0,27

**PCFX35**

- ① 1x TF140703
- L = 35  
kg ~0,31

**PCFX50**

- ① 1x TF140704
  - ② 1x PCSP10B
  - ③ 1x PCSP10G
  - ④ 1x M5X85ISO4762
- L = 50  
kg ~0,45

**PCFX70**

- ① 1x TF140705
- L = 70  
kg ~0,62

Auf Anfrage in Stahl erhältlich  
On request also in steel

Bestellbeispiel / Ordering example: PCFX30

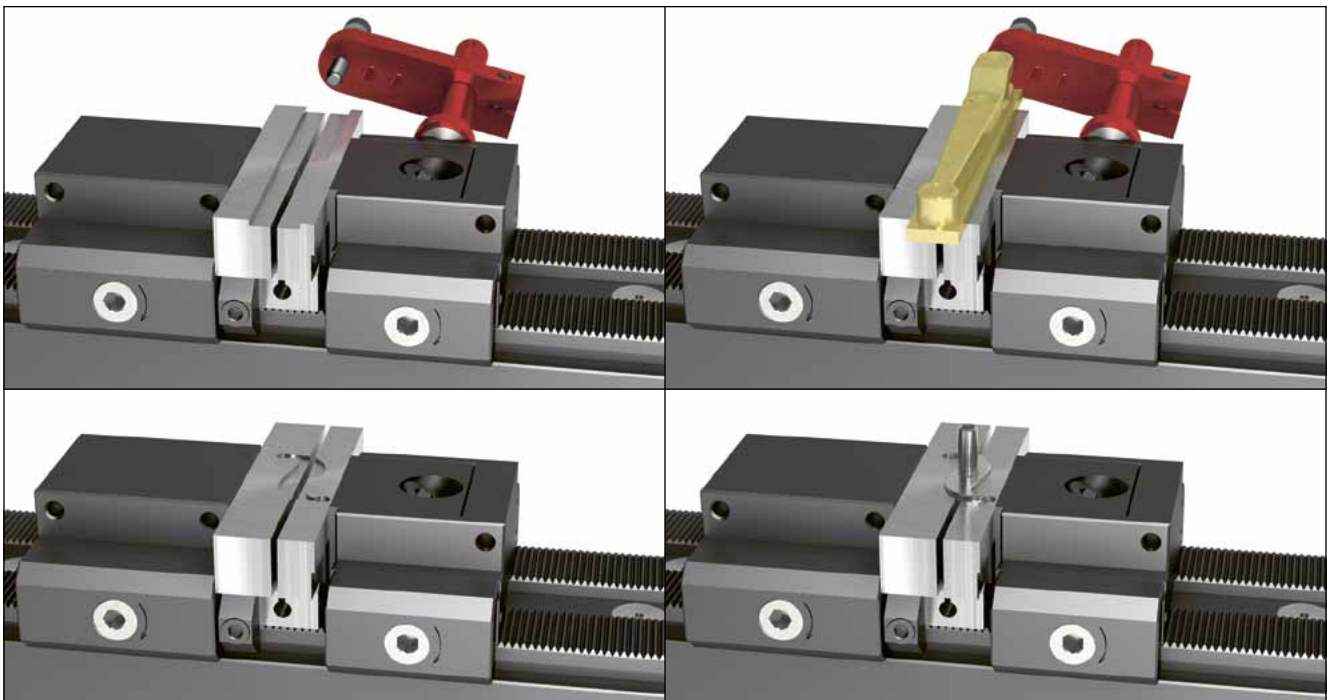

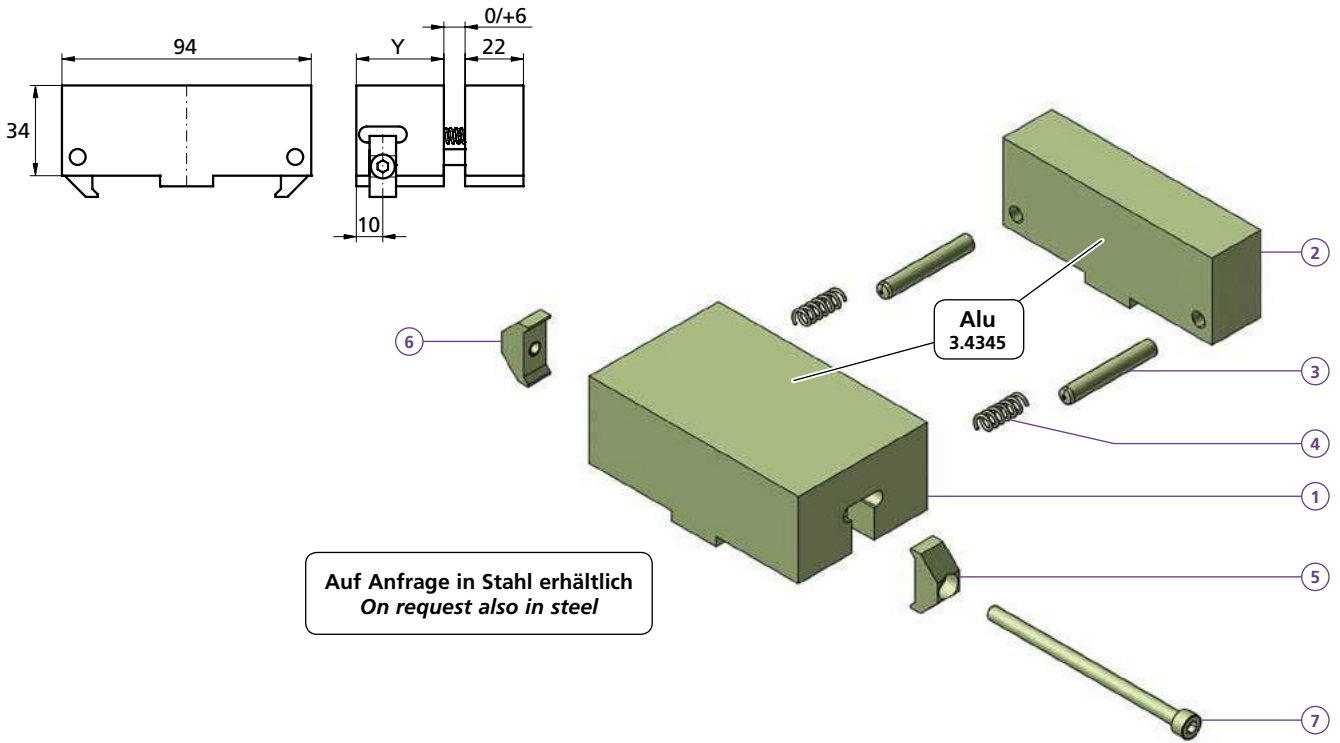

Auf Anfrage in Stahl erhältlich  
On request also in steel

**PCFM3322**

- ① 1x PCFM33
- ② 1x PCFF22
- ③ 2x CCBO0801
- ④ 2x FED0618
- ⑤ 1x PCSP10B
- ⑥ 1x PCSP10G
- ⑦ 1x M5X85ISO4762

Y = 33  
kg ~0,52

**PCFM5822**

- ① 1x PCFM58

Y = 58  
kg ~0,75

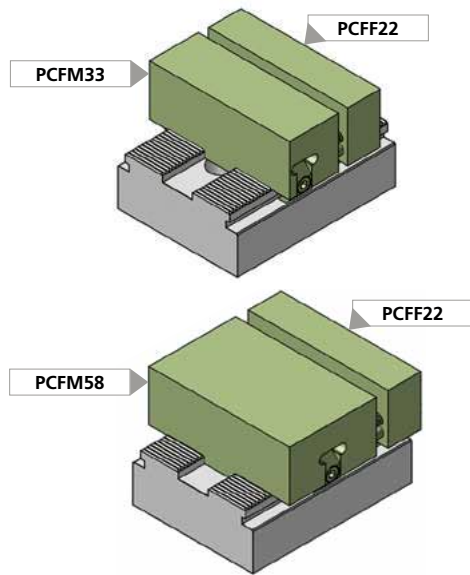

**PCSP10SET** kg ~0,04

- ① 1x PCSP10G
- ② 1x PCSP10B
- ③ 1x M5X85ISO4762

Bestellbeispiel / Ordering example: **PCFM3322**

**Anschlagbacke flach**  
*Jaw flat stop*

	B	H	kg
PCUD34093TG	93	34	~0,11
PCUD49093TG	93	49	~0,14

**Unterlagen gehärtet und geschliffen**  
*Parallels hardened and ground*

Type		B	H	kg
I	PCUD14093	93	14	~0,05
I	PCUD20093	93	20	~0,06
I	PCUD24093	93	24	~0,08
I	PCUD29093	93	29	~0,09
II	PCUD31093	93	31	~0,10
I	PCUD34093	93	34	~0,11
I	PCUD39093	93	39	~0,12
I	PCUD44093	93	44	~0,14
II	PCUD46093	93	46	~0,14
I	PCUD47093	93	37	~0,15

# Niederzugbacke für Anschlagseite Pull down jaws for solid reference face



powerCLAMP

**HM**  
Hartmetallbeschichtet  
Carbide coated

ohne PCU / without PCU

mit PCU / with PCU

PCU20093 p. 112

Anschlagmodul  
End module

beidseitiger Niederzug  
Double sided  
pull-down modules

Spannmodul  
Clamping module

PC4834N			
1	1x	PC4834NSL	
2	1x	PC4834NB1	
3	2x	M5X8ISO4762	
4	2x	PCD008	
5	2x	M5X20ISO4762	
X	=	48	
kg		~0,17	

PC9434N			
1	1x	PC9434NSL	
2	1x	PC9434NB1	
X	=	94	
kg		~0,2	

Bestellbeispiel / Ordering example: **PC4834N**

## Magnetunterlage Magnetic base

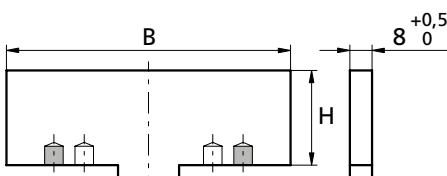

	B	H	kg
PCUM1409308	93	14	~0,09
PCUM2009308	93	20	~0,13
PCUM2409308	93	24	~0,15
PCUM2909308	93	29	~0,18
PCUM3109308	93	31	~0,20
PCUM3409308	93	34	~0,21
PCUM3909308	93	39	~0,24
PCUM4409308	93	44	~0,27
PCUM4609308	93	46	~0,28

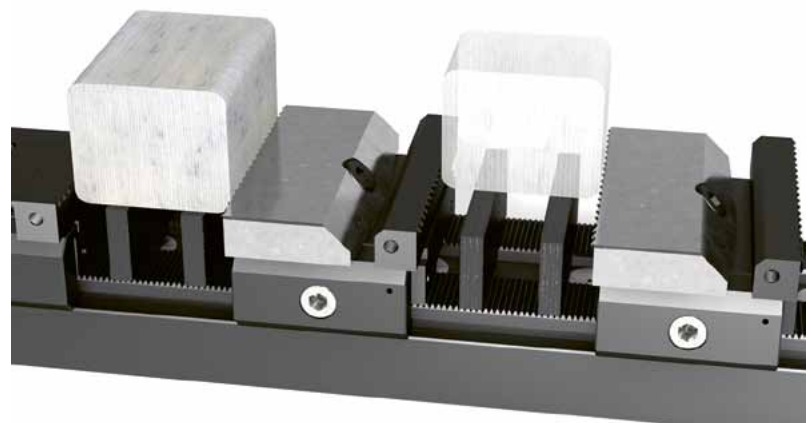

Bestellbeispiel / Ordering example: **PCUM1409308**

Separat bestellen / Separate order





Type	19mm	B	H	kg	Type	34mm	B	H	kg	Type	48mm	B	H	kg	Type	61mm	B	H	kg	Type	94mm	B	H	kg	
I	PCU20018	18	20	~0,04	I	PCU20033	33	20	~0,04	I	PCU20047	47	20	~0,04	I	PCU20060	60	20	~0,04	I	PCU14093	93	14	~0,04	
I	PCU24018	18	24	~0,04	I	PCU24033	33	24	~0,05	I	PCU24047	47	24	~0,05	I	PCU24060	60	24	~0,05	I	PCU20093	93	20	~0,06	
I	PCU29018	18	29	~0,05	I	PCU29033	33	29	~0,05	I	PCU29047	47	29	~0,05	I	PCU29060	60	29	~0,06	I	PCU24093	93	24	~0,07	
I	PCU31018	18	31	~0,05	I	PCU31033	33	31	~0,05	II	PCU31047	47	31	~0,05	I	PCU31060	60	31	~0,06	I	PCU29093	93	29	~0,09	
I	PCU34018	18	34	~0,05	I	PCU34033	33	34	~0,06	I	PCU34047	47	34	~0,07						I	PCU31093	93	31	~0,09	
I	PCU39018	18	39	~0,05	I	PCU39033	33	39	~0,06	I	PCU39047	47	39	~0,07	68mm	B	H	kg	I	PCU34093	93	34	~0,10		
I	PCU44018	18	44	~0,05	I	PCU44033	33	44	~0,07	I	PCU44047	47	44	~0,08	I	PCU20067	67	20	~0,04	I	PCU39093	93	39	~0,11	
I	PCU46518	18	46,5	~0,06	II	PCU46033	33	46	~0,06	I	PCU46047	47	46	~0,08	I	PCU24067	67	24	~0,05	I	PCU44093	93	44	~0,12	
					I	PCU46533	33	46,5	~0,07						I	PCU29067	67	29	~0,06	I	PCU46093	93	46	~0,14	
															I	PCU31067	67	31	~0,07	I	PCU47093	93	47	~0,14	
	26mm	B	H	kg		43mm	B	H	kg		58mm	B	H	kg											
I	PCU20025	25	20	~0,04	I	PCU20042	42	20	~0,04	I	PCU20057	57	20	~0,04											
I	PCU24025	25	24	~0,05	I	PCU24042	42	24	~0,05	I	PCU24057	57	24	~0,05	78mm	B	H	kg							
I	PCU29025	25	29	~0,05	I	PCU29042	42	29	~0,05	I	PCU29057	57	29	~0,06	I	PCU20077	77	20	~0,05	I	PCU20124	124	20	~0,08	
I	PCU31025	25	31	~0,05	I	PCU31042	42	31	~0,06	I	PCU31057	57	31	~0,06	I	PCU24077	77	24	~0,06	I	PCU24124	124	24	~0,09	
I	PCU34025	25	34	~0,05	I	PCU34042	42	34	~0,06					I	PCU29077	77	29	~0,07	I	PCU29124	124	29	~0,11		
I	PCU39025	25	39	~0,06	I	PCU39042	42	39	~0,07					I	PCU31077	77	31	~0,08	I	PCU31124	124	31	~0,12		
I	PCU44025	25	44	~0,06	I	PCU44042	42	44	~0,07					I	PCU34077	77	34	~0,08	I	PCU34124	124	34	~0,13		
I	PCU46525	25	46,5	~0,06	I	PCU46042	42	46	~0,08					I	PCU39077	77	39	~0,09	I	PCU39124	124	39	~0,15		
					I	PCU47042	42	47	~0,08					I	PCU44077	77	44	~0,11	I	PCU44124	124	44	~0,17		
																				II	PCU46124	124	46	~0,18	

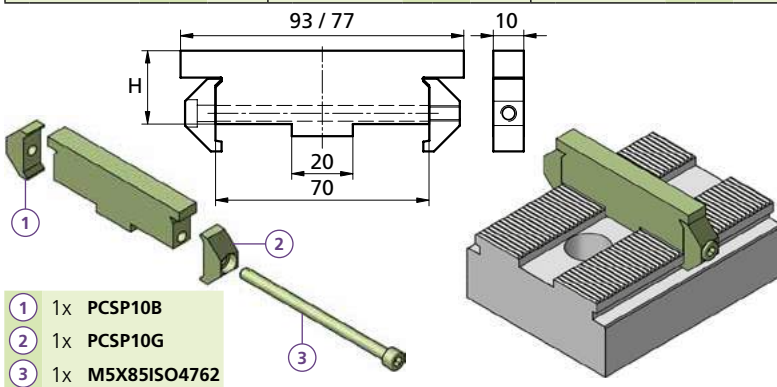
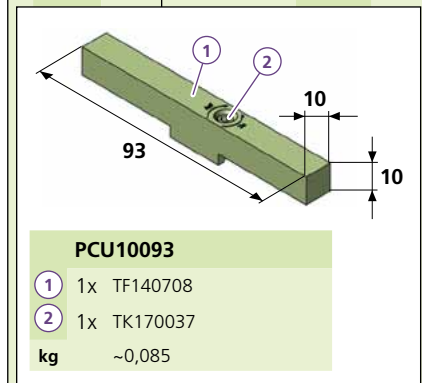
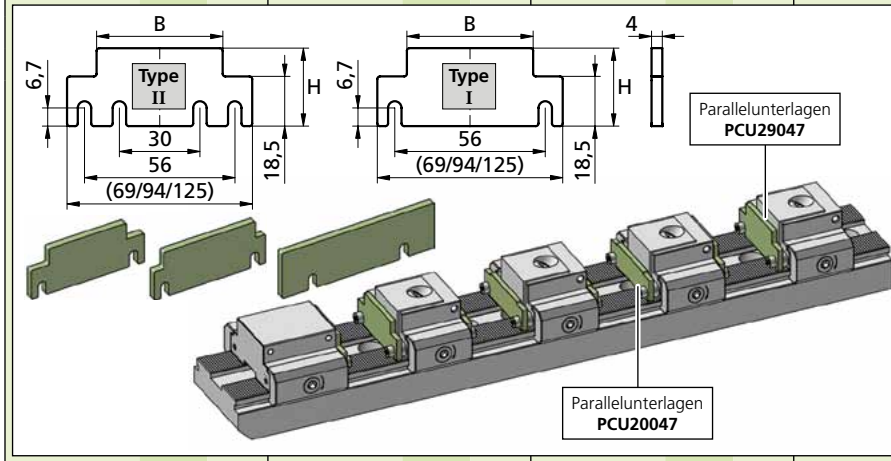

weich / soft	1.7225	hart / hardened	HV700 x0,2mm		
H= +0,15 +0,25	H	H	H		
PCU20077B10-W	20	~0,15	PCU20077B10	20	~0,15
PCU24093B10-W	24	~0,19	PCU24093B10	24	~0,19
PCU39093B10-W	39	~0,29	PCU29093B10	29	~0,23
PCU44093B10-W	44	~0,33	PCU31093B10	31	~0,24
PCU46093B10-W	46	~0,34	PCU34093B10	34	~0,27
			PCU39093B10	39	~0,29
			PCU44093B10	44	~0,33
			PCU46093B10	46	~0,34

### Unterlagen- und Fräsanschlaghalter Holder for parallels and workpiece stop

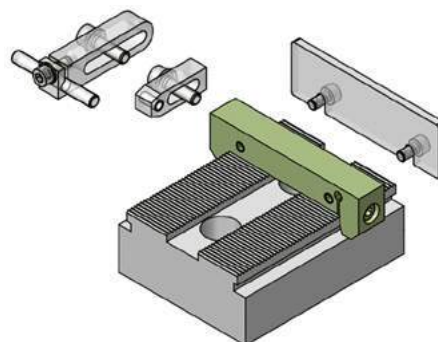
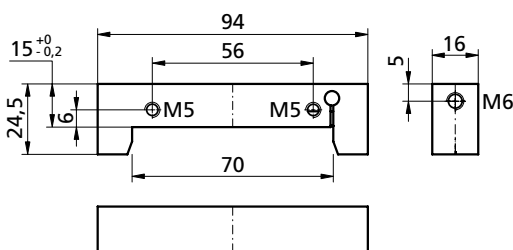

**PCUH2594**

- 1 1x TF140706
- 2 2x M5X8ISO4762
- 3 1x M5X22ISO4762

kg ~0,19

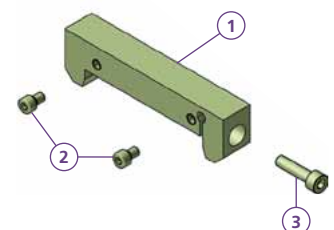

Bestellbeispiel / Ordering example: **PCUH2594**

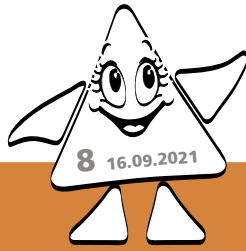
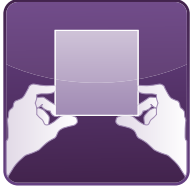



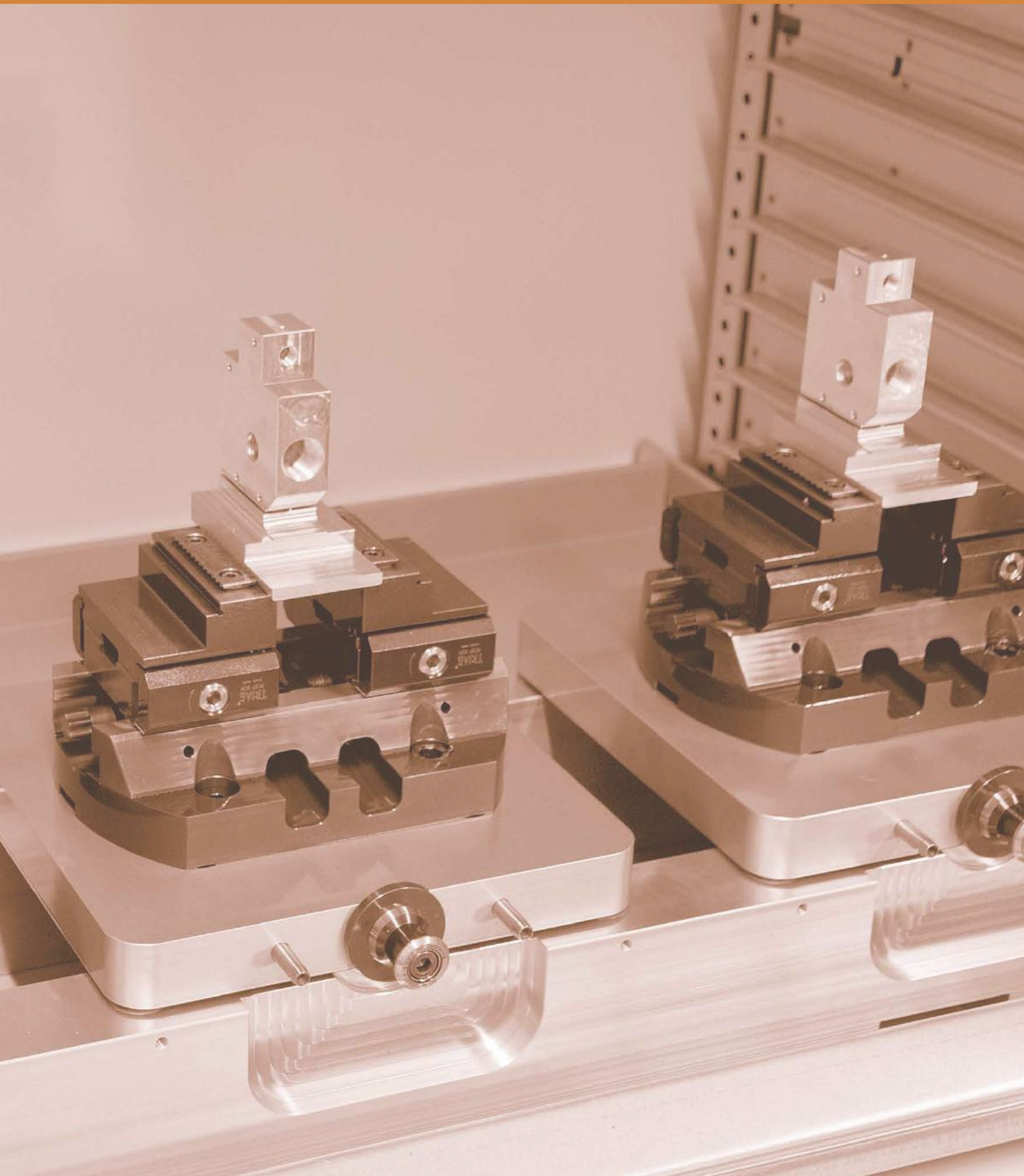

**triCENTRO**



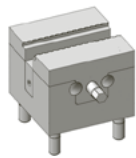

Einleitung und Anwendungsbeispiele | *Introduction and examples of application* ..... 115

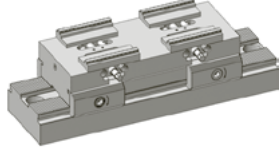
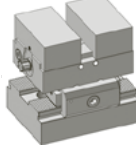
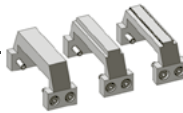
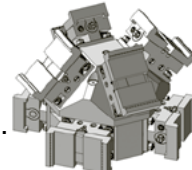
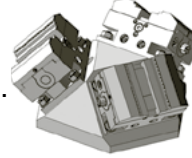
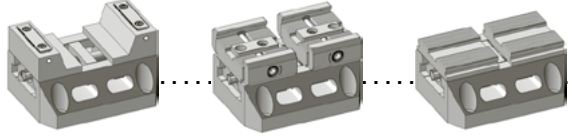
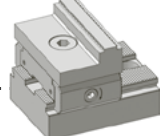
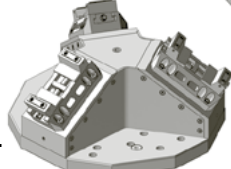
Micro - Zentrierspanner   <i>Micro - self centering vise</i> .....		116 - 117
5-Achsen Zentrischspannblock <i>Self centering vise block 35°...</i> .....	 <b>SPUTNIK I</b>	118
5-Achsen Zentrischspannblock <i>Self centering vise block 45°...</i> .....	 <b>SPUTNIK I</b>	119
5-Achsen Zentrischspannblock <i>5-Axis self centering vise block 20°-3</i> .....	 <b>SPUTNIK I-3</b>	122
Kompakter Zentrischspanner   <i>Compact self centering vise</i> .....		123 - 124
Mini Zentrierspanner   <i>Mini - self centering vise</i> .....		126 - 129
Zentrischspanner mit Anschlagbrücke   <i>Self centering vise with center stop</i> .....		130
5-Achsen Zentrischspannblock <i>Self centering vise block 45° / 90°-4-8-12</i> .....	 <b>SPUTNIK II</b>	133
5-Achsen Zentrischspannblock 45°-3 <i>Self centering vise block 45°-3</i> .....	 <b>SPUTNIK II-3</b>	136
Zentrischspanner X M B Serien <i>Self centering vises X M B series</i> .....		137 - 146
Präge- Pendelbacken Set für Zentrischspanner ZSM <i>Stamping swiveling jaws for self centering vise ZSM</i> .....		148
5-Achsen Zentrischspannblock <i>Self centering vise block 35°-3</i> .....	 <b>SPUTNIK III</b>	153 - 154



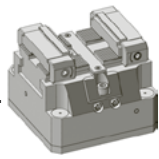
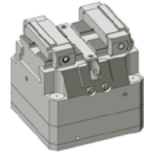
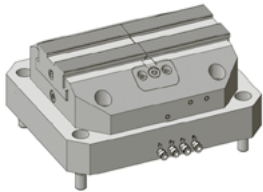

<b>ZSP Micro - Zentrischspanner</b> <b>ZSP Micro - self centering vise</b> .....		..... 156
<b>ZSP125 Mini - Pneumatischer Zentrischspanner (einfacher Kolben)</b> <b>ZSP125 Mini - Pneumatic self centering vise (single piston)</b> .....		..... 157
<b>ZSP125 Mini - Pneumatischer Zentrischspanner (Doppelkolben)</b> <b>ZSP125 Mini - Pneumatic self centering vise (Double piston)</b> .....		..... 158
<b>ZSP Grande - Pneumatischer Zentrierspanner</b> <b>ZSP Grande - Pneumatic self centering vise</b> .....		..... 160 - 161

**Triag International AG** bietet ein breites Sortiment an Zentrischspannern an. Neben den Zentrischspannern, die auf die Schienensysteme Power Clamp das Nullpunktsystem oppSystem passen, sind auch Ausführungen für Lochraster erhältlich.

Mit unseren modularen Zentrischspannblöcken bieten wir eine optimale Lösung für die Mehrfachspannung in Ihrer 5-Achs Fräsmaschine an. Für alle Zentrischspanner sind verschiedene Aufsatz- und Prägebacken erhältlich.

*Triag International AG offers a wide range of self centering vices. In addition to the self centering vice that fit into the rail systems Power Clamp the zero point system oppSystem, mechanical self centering vice are also available.*

*With our modular self centric vice blocks we offer an optimal solution for multiple workholding in your 5 axis milling machine. Different false jaws and stamping jaws are available for all self centering vices.*

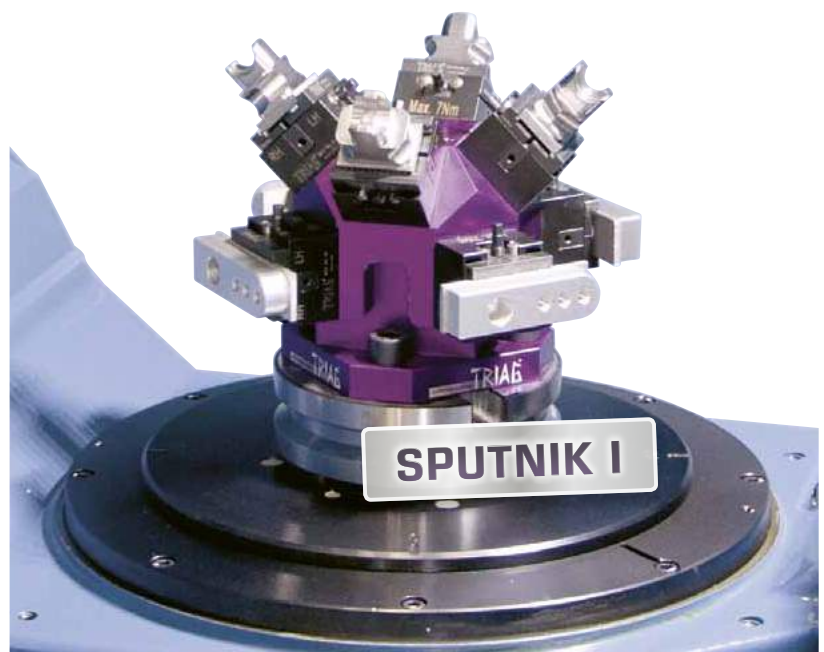
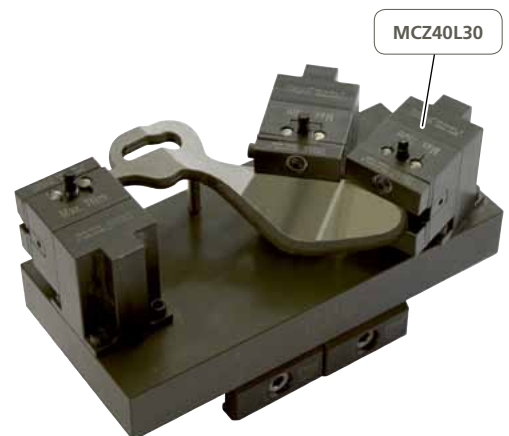



prägen  
stamping



glatt  
flat



**MCZ40L30PRG13**

1x MCZ40L30

1x **B190-13** kg ~0,09

*i* 57HRC

**A** 3 – 13 mm

kg ~0,34

**Prägebacken / direct stamping jaws**

**MCZ40L30PRG22**

1x MCZ40L30

1x **B190-22** kg ~0,08

*i* 57HRC

**A** 12 – 22 mm

kg ~0,33

**MCZ40L30PRG31**

1x MCZ40L30

1x **B190-31** kg ~0,08

*i* 57HRC

**A** 21 – 31 mm

kg ~0,32

**MCZ40L30W6\***

1x MCZ40L30

1x **B190W6-40** kg ~0,08

H = 38 mm

H1 = 6 mm

*i* \* = weich / soft

**A** 0 – 10 mm

kg ~0,33

**weichen Stahlbacken / soft steel jaws**

**MCZ40L30W10\***

1x MCZ40L30

1x **B190W10-40** kg ~0,12

H = 42 mm

H1 = 10 mm

*i* \* = weich / soft

**A** 0 – 10 mm

kg ~0,37

**MCZ40L30W20\***

1x MCZ40L30

1x **B190W20-40** kg ~0,22

H = 52 mm

H1 = 20 mm

*i* \* = weich / soft

**A** 0 – 10 mm

kg ~0,47

Drehmoment Torque		Spannkraft Workholding force		
Nm	(lb-ft)	~daN	~(lb)	~t
4	3	= 457	1'007	0,46
5	3,7	= 571	1'259	0,57
6	4,4	= 686	1'512	0,69
7	5,2	= 800	1'764	0,8

**Befestigungsbohrbild / Mounting hole pattern**

**MCZ40L30W30\***

1x MCZ40L30

1x **B190W30-40** kg ~0,32

H = 62 mm

H1 = 30 mm

*i* \* = weich / soft

**A** 0 – 10 mm

kg ~0,57

**Bestellbeispiel / Ordering example :**  
3 x MCZ40L30PRG13 & 1 x Nuss 1/4 - sw 4,5

Separat bestellen / Separate order

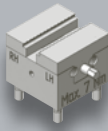

prägen  
stamping



glatt  
flat



triCENTRO

## mit Prägebacken / direct stamping jaws

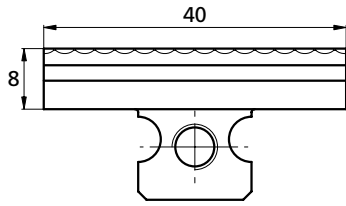

## mit weichen Stahlbacken / with soft steel jaws

**H1: Zum Erstellen Ihrer individuellen Formbacke:**  
Schnittzeichnung zum Ermitteln der maximalen Bearbeitungsprofiltiefe

**H1: If a dedicated jaw is being machined:**  
Sectional drawing to determine the maximum machining depth

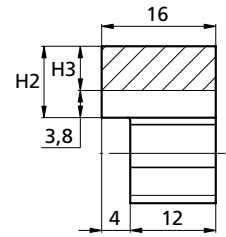

TH130073

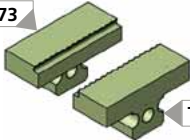

TH130072



B190-13

kg ~0,09

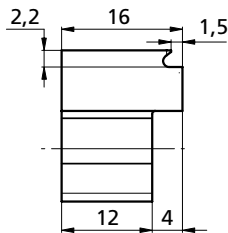

B190W6-40\* kg ~0,08

H2 = 6 mm  
H3 = 2,2 mm

TH130025

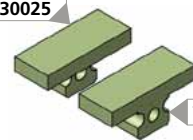

TH130028

TH140153

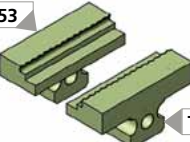

TH140152



B190-22

kg ~0,08

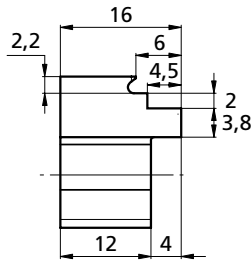

B190W10-40\* kg ~0,12

H2 = 10 mm  
H3 = 6,2 mm

TH140147

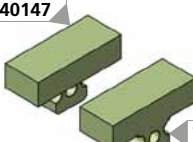

TH140146

TH140155

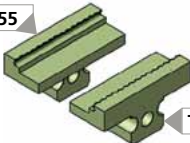

TH140154



B190-31

kg ~0,08

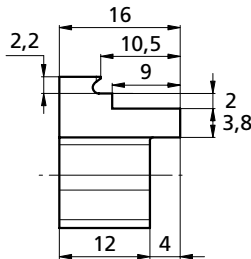

B190W20-40\* kg ~0,22

H2 = 20 mm  
H3 = 16,2 mm

TH140149

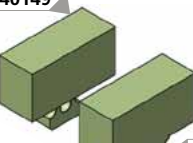

TH140148

TH140151

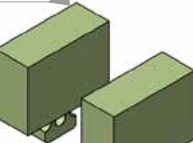

TH140150



B190W30-40\* kg ~0,32

H2 = 30 mm  
H3 = 26,2 mm

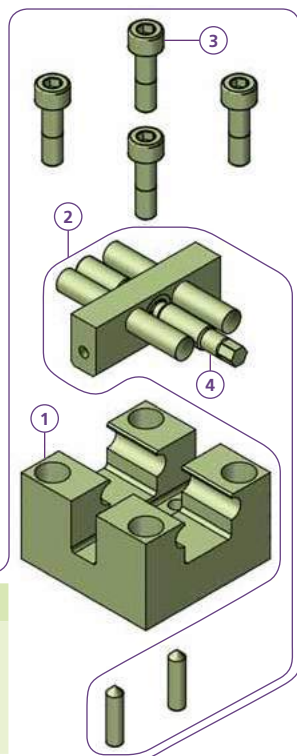
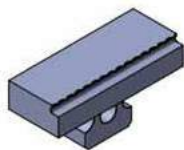

MCZ40L30

kg

- ① 1x TH130024 ~0,18
- ② 1x PCS6M50SET ~0,05
- ③ 4x M550
- ④ 1x TH130026 ~0,01

**WICHTIG!**

Bitte separat bestellen

**IMPORTANT!**

Please order separately

Nuss 1/4 - sw 4,5



## ACHTUNG / CAUTION

Die Angaben der Spannbereiche bei clamping ranges for den verschiedenen the different jaws Backen sind unbedingt zu beachten und einzuhalten! must be strictly folding to be observed and followed!  
Bei unsachgemäßer use, TRIAG International übernimmt TRIAG International keine Haftung. liability.

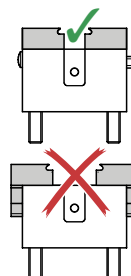





**Sputnik I**

Die Sputnik Baureihe wurde speziell für die effizientere Nutzung von 5-Achsen Maschinen entwickelt. Dabei zeichnen sich alle drei Baureihen der Sputnik Serie mit unterschiedlichen Merkmalen aus.

Sehr kompakte Bauweise zur Aufnahme von 4 oder 8 Micro Zentrischspannmodulen. Für die Rohteilebearbeitung gibt es drei Bausätze Prägebacken (3–13 mm, 12–22 mm und 21–31 mm).

Für die zweite Spannung gibt es vier Sätze unterschiedlicher Backenrohlinge für die Einarbeitung einer Kontur. Die Spannkraft liegt bei 7 Nm 0,8t 800 daN.

**Sputnik I**

The Sputnik series was specially developed to improve the outputs of 5-axis machines. All three types of the Sputnik series have different features.

Very compact design to hold 4 or 8 micro self centering clamping modules. There are three assembly kits of stamping jaws (3–13 mm, 12–22 mm and 21–31 mm) for raw part machining.

For the second clamping, there are four sets of different jaw blanks to integrate any shapes. The clamping force is at 7 Nm 0.8t 800 daN.

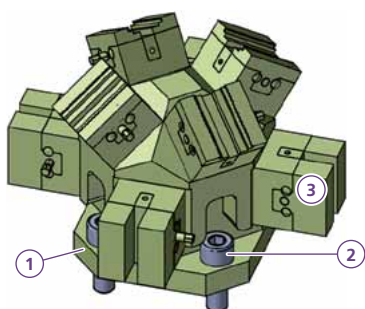
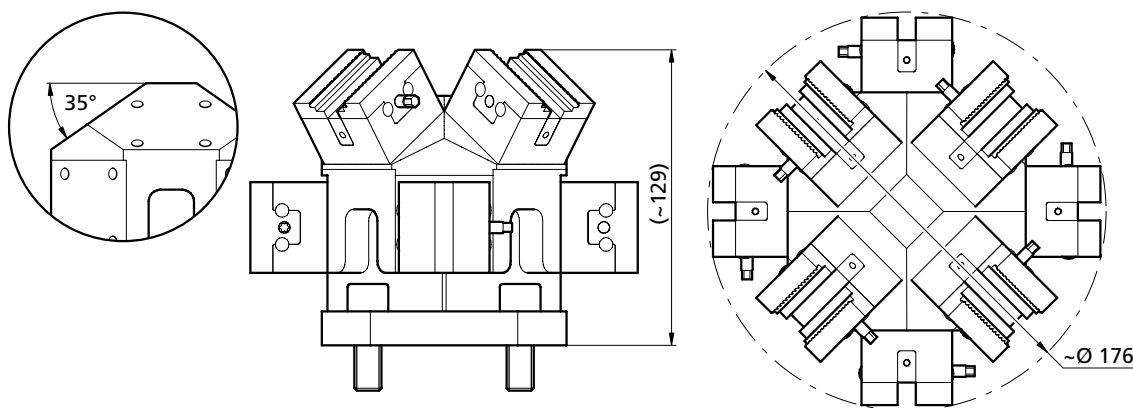

<b>35°</b>	<b>UB5AXMCZ40-35SET8</b>
1	1x TB170676
2	4x M12X35ISO4762
3	8x Ihre Wahl/ Your choice
kg	~5,1



Detailzeichnung zu dieser Schnittstelle  
Detail drawing to interface

p. 116 - 117

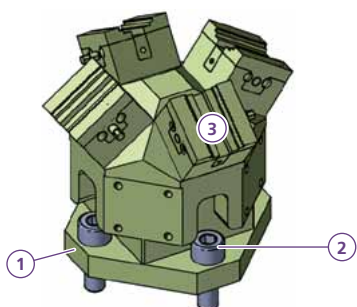

<b>35°</b>	<b>UB5AXMCZ40-35SET4</b>
1	1x TB170676
2	4x M12X35ISO4762
3	4x Ihre Wahl/ Your choice
kg	~3,2



Detailzeichnung zu dieser Schnittstelle  
Detail drawing to interface

p. 116 - 117

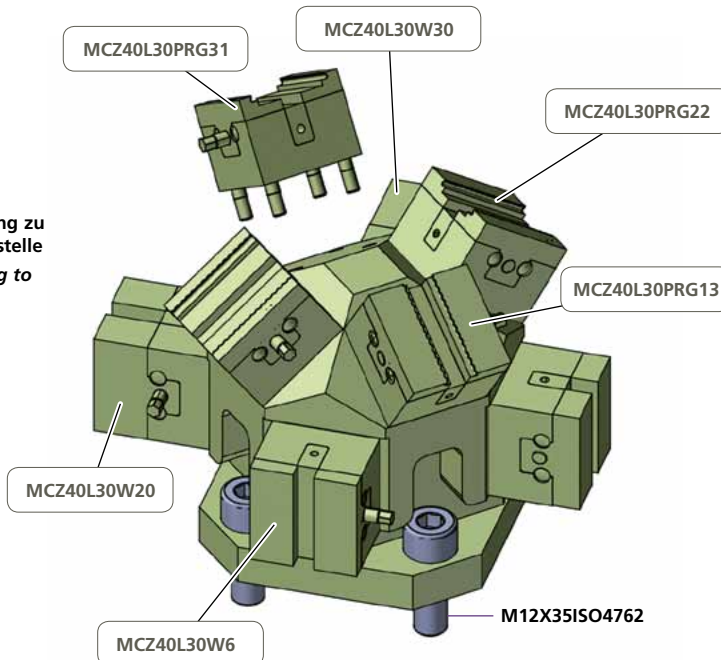

**WICHTIG!**  
Bitte separat bestellen

**IMPORTANT!**  
Please order separately

Nuss 1/4 - sw 4,5

Bestellbeispiel / Ordering example:  
2 x UB5AXMCZ40-35SET8 & 8 x MCZ40L30W10 &  
8 x MCZ40L30PRG22 & 1 x Nuss 1/4 - sw 4,5

Separat bestellen / Separate order

# 5-Achsen Zentrischspannblock Self centering vise block

# 45° ...

## SPUTNIK I



UB5AXMCZ40-45SET (8 / 4 / OPBM)

UB5AXMCZ40-45SET8-ER

triCENTRO

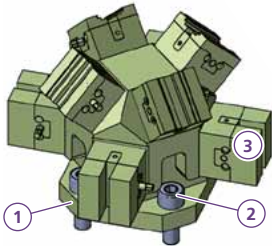

- UB5AXMCZ40-45SET8**
- 1x TK140867
  - 4x M12X35ISO4762
  - 8x Ihre Wahl/ Your choice
- kg ~5,2



Detailzeichnung zu dieser Schnittstelle  
Detail drawing to interface

p. 116 - 117

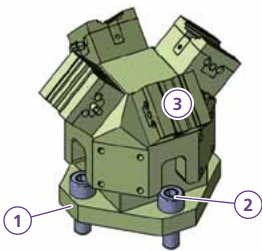
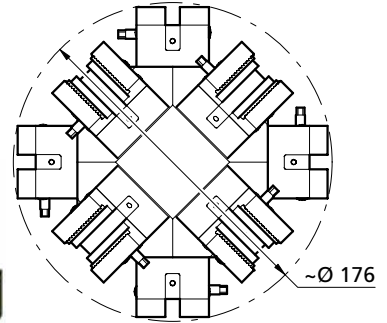
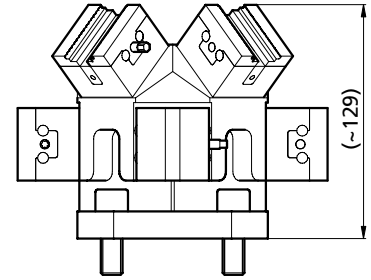
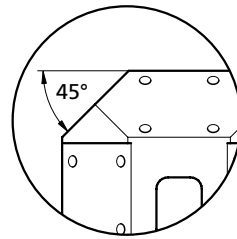

- UB5AXMCZ40-45SET4**
- 1x TK140867
  - 4x M12X35ISO4762
  - 4x Ihre Wahl/ Your choice
- kg ~4,2



Detailzeichnung zu dieser Schnittstelle  
Detail drawing to interface

p. 116 - 117

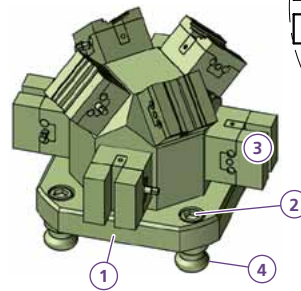

- UB5AXMCZ4045SET8-OPBM**
- 1x TK160869
  - 4x M12X20ISO4762
  - 8x Ihre Wahl/ Your choice
  - 4x OPBM18M12
- kg ~6,2



Detailzeichnung zu dieser Schnittstelle  
Detail drawing to interface

p. 116 - 117

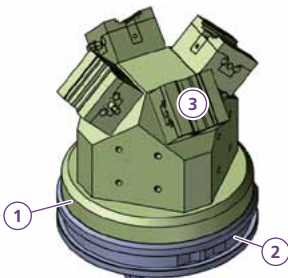

- UB5AXMCZ40-45SET4-ER**
- 1x TB161062
  - 1x ER041912 EROWA ITS-Palette
  - 4x Ihre Wahl/ Your choice
- kg ~4,1



Detailzeichnung zu dieser Schnittstelle  
Detail drawing to interface

p. 116 - 117

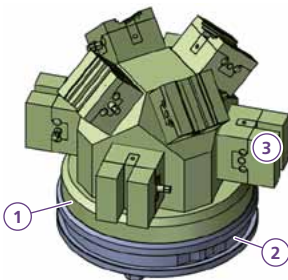

- UB5AXMCZ40-45SET8-ER**
- 1x TB161062
  - 1x ER041912 EROWA ITS-Palette
  - 8x Ihre Wahl/ Your choice
- kg ~6,1



Detailzeichnung zu dieser Schnittstelle  
Detail drawing to interface

p. 116 - 117

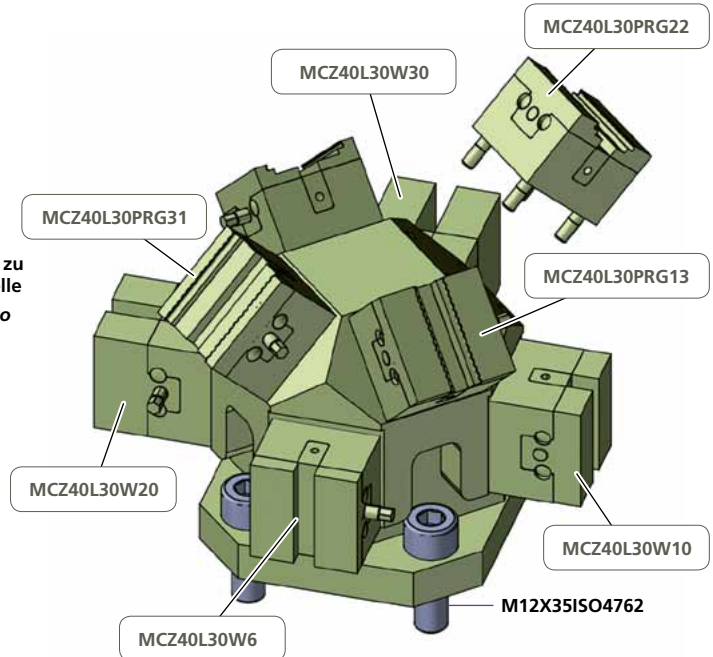

**WICHTIG!**  
Bitte separat bestellen  
**IMPORTANT!**  
Please order separately

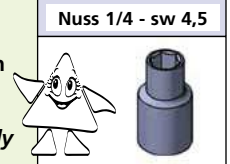

Bestellbeispiel / Ordering example:  
2 x UB5AXMCZ40-45SET8 & 8 x MCZ40L30W20 &  
8 x MCZ40L30PRG22 & 1 x Nuss 1/4 - sw 4,5

Separat bestellen / Separate order

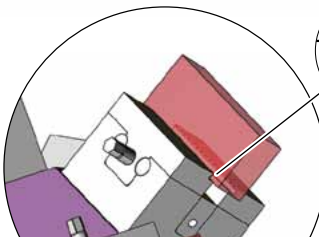
**MCZ40L30PRG13**  
◀ 3 – 13 mm ▶  
Spannbereich  
Clamping width



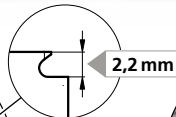
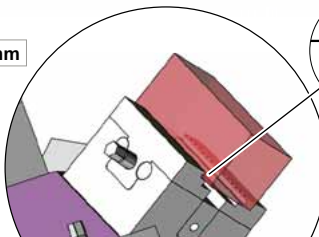

**MCZ40L30PRG22**  
◀ 12 – 22 mm ▶  
Spannbereich  
Clamping width

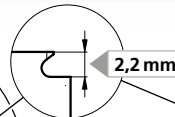
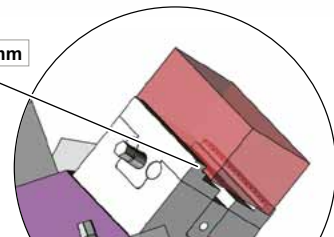

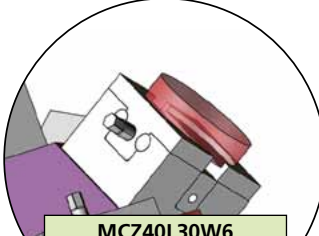

**MCZ40L30PRG31**  
◀ 21 – 31 mm ▶  
Spannbereich  
Clamping width

p. 116 Micro Zentrischspanner / Micro - self centering vise

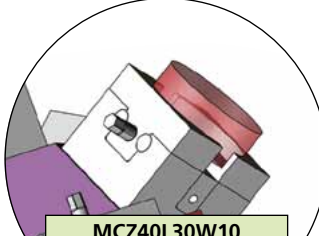

**MCZ40L30W6**  
Zum Erstellen Ihrer individuellen Formbacke  
If a dedicated jaw is being machined



**MCZ40L30W10**  
Zum Erstellen Ihrer individuellen Formbacke  
If a dedicated jaw is being machined

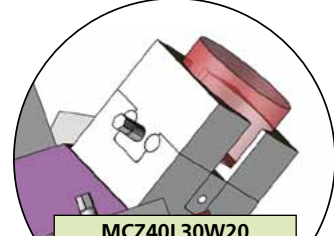

**MCZ40L30W20**  
Zum Erstellen Ihrer individuellen Formbacke  
If a dedicated jaw is being machined

p. 116 Micro Zentrischspanner / Micro - self centering vise



Anwendungsbilder  
Pictures of application to

Micro

Zentrischspanner  
self centering vise



triCENTRO

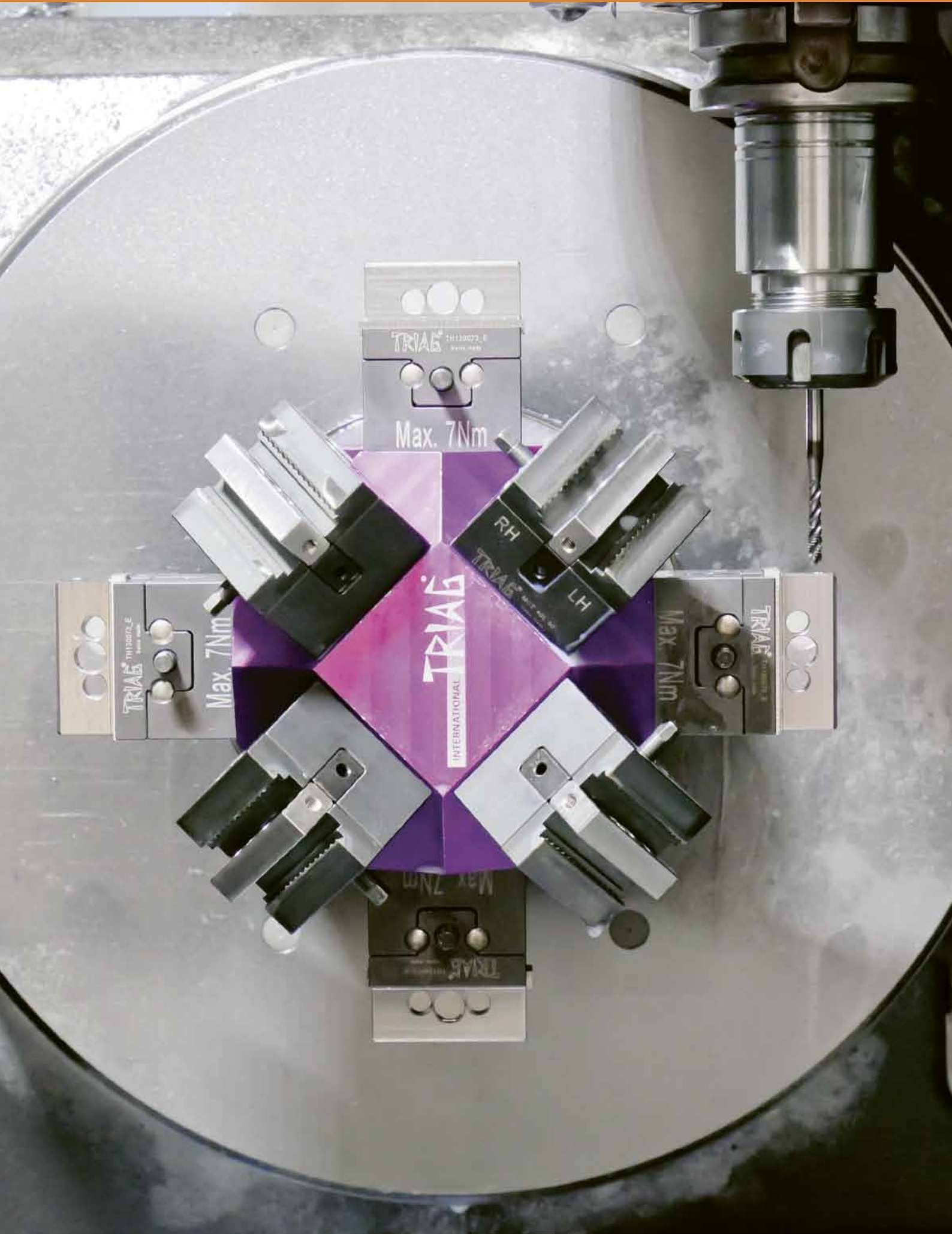



SPUTNIK I-3

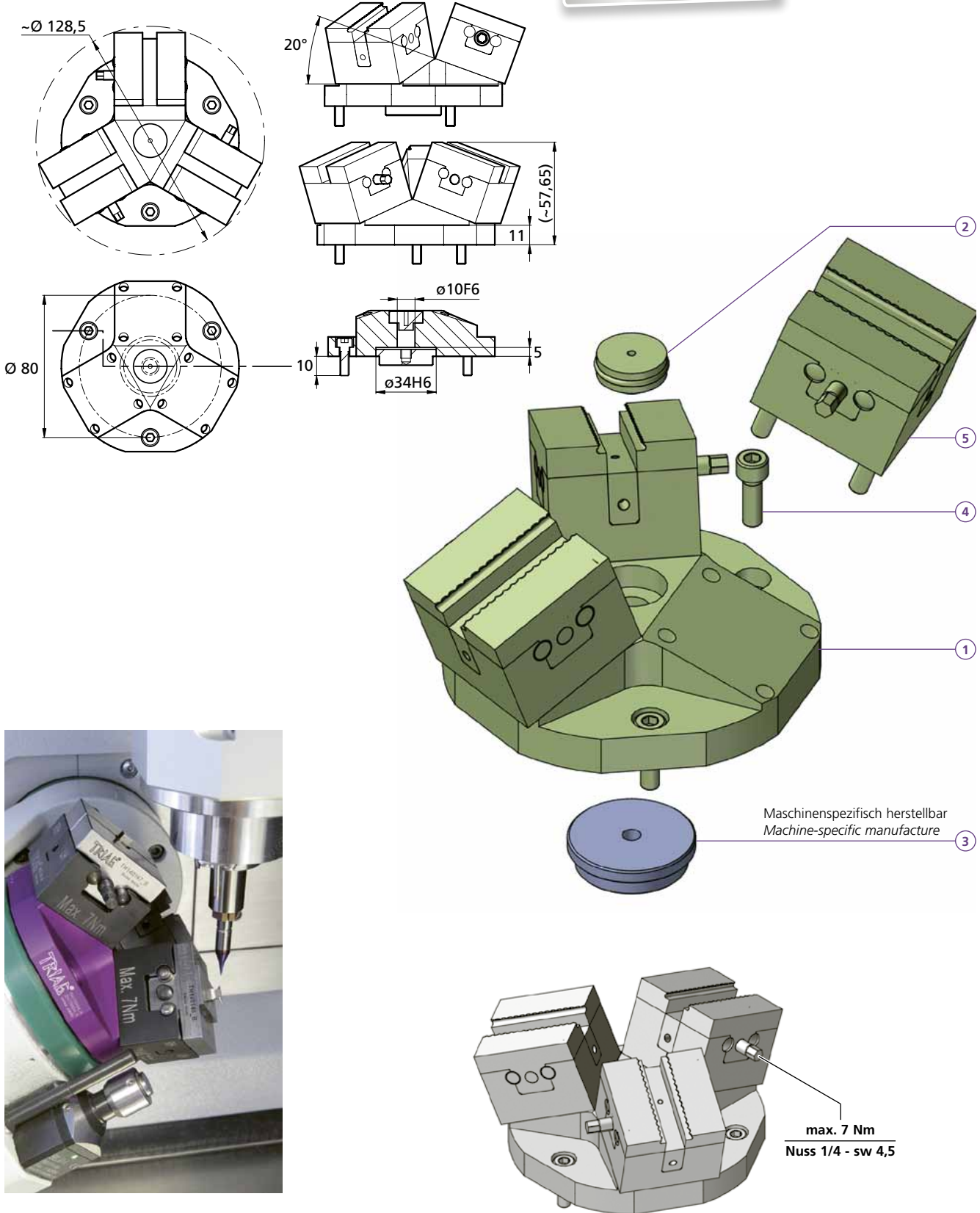

20°	<b>UB5AXSET18-3</b>
1	1x TH170934
2	1x PCPF16L6
3	1x TH171176
4	3x M5X16ISO4762
5	3x Ihre Wahl / Your choice
kg	~1,45

p. 116 - 117

**WICHTIG!**  
Bitte separat bestellen!

**IMPORTANT!**  
Please order separately!

Nuss 1/4 - sw 4,5

Bestellbeispiel / Ordering example : 1 x UB5AXSET18-3 & 1x TH171176 & 3x M5x16

Separat bestellen / Separate order

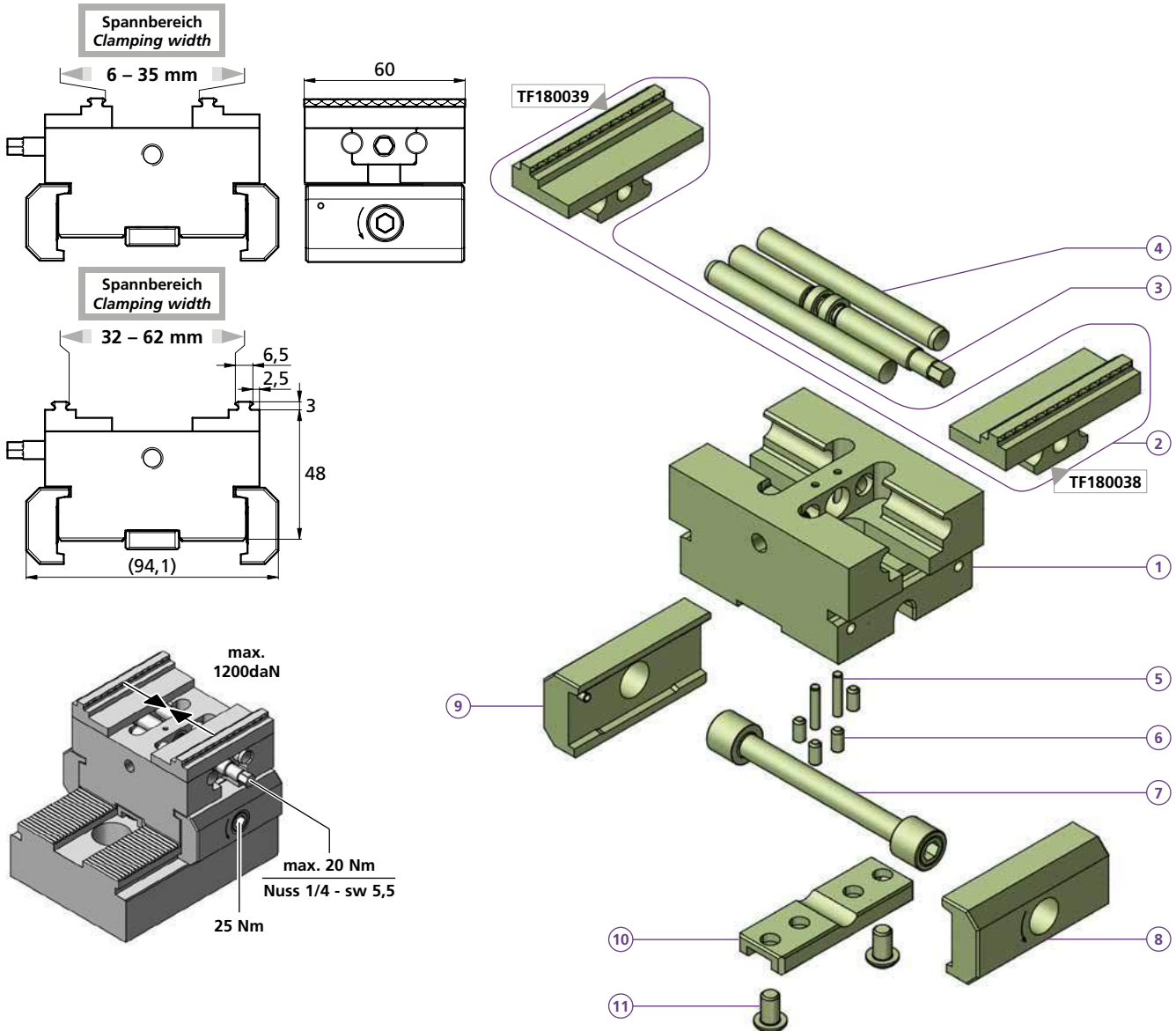

Drehmoment Torque		Spannkraft Workholding force		
Nm	(lb-ft)	~daN	~(lb)	~t
5	3,7	= 410	900	0,41
10	7,4	= 830	1'830	0,83
15	11,0	= 1'250	2'760	1,25
20	14,8	= 1'650	3'640	1,65

PCZ80L40PRG62	
1	1x TF180182
2	1x B210-62
3	1x TB150998
4	2x 8h6x80 DIN6325
5	2x 3h6x16 DIN6325
6	4x M4X8DIN913
7	1x PCS14
8	1x PCSP60R
9	1x PCSP60L
10	1x PCGUW20
11	2x M6X10ISO7380
kg	~1,71

**Weiche Backen zu Kompakter Zentrischspanner**  
**Soft jaws for compact self centering vise**

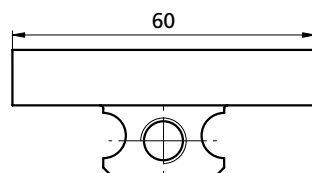

**B212W11-60\*** kg ~0,31  
H = 11 mm  
H1 = 6,5 mm

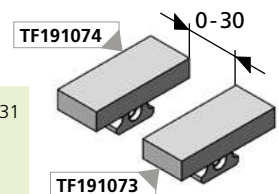

**H1: Zum Erstellen Ihrer individuellen Formbacke:**  
Schnittzeichnung zum Ermitteln der maximalen Bearbeitungsprofiltiefe

**B212W20-60\*** kg ~0,52  
H = 20 mm  
H1 = 15,5 mm

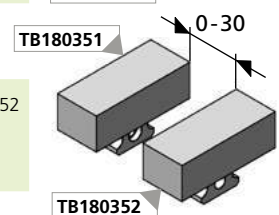

**H1: If a dedicated jaw is being machined:**  
Sectional drawing to determine the maximum machining depth

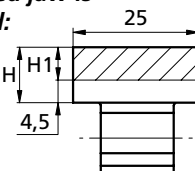

**WICHTIG!**  
Bitte separat bestellen!  
**IMPORTANT!**  
Please order separately!

Nuss 1/4 - sw 5,5



Bestellbeispiel / Ordering example: PCZ80L40PRG62 & 1 x Nuss 1/4 - sw 5,5

\* = weich / soft (1.7225 Vergütungsstahl / Tempering steel)



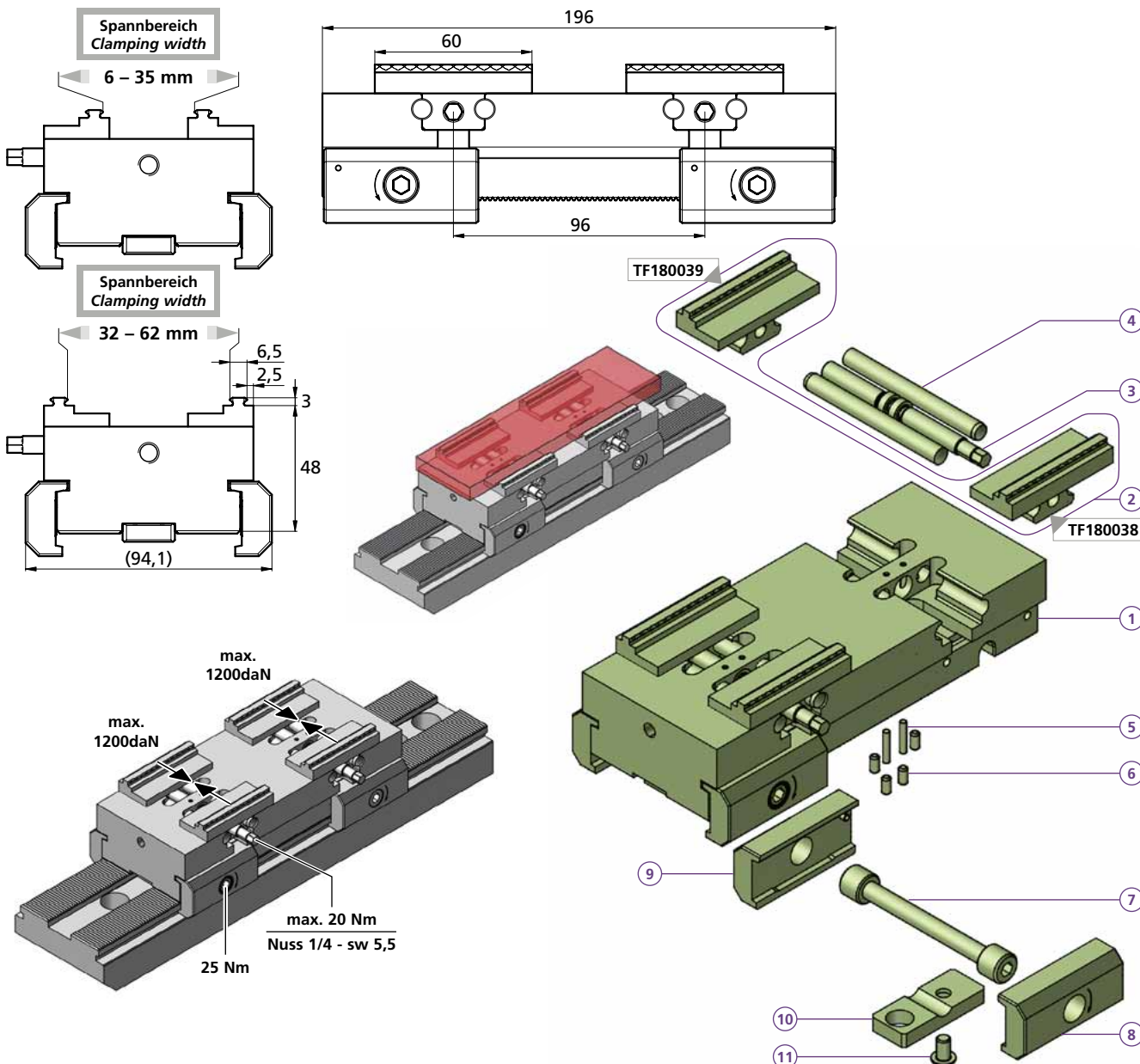

Drehmoment Torque		Spannkraft Workholding force		
Nm	(lb-ft)	~daN	~(lb)	~t
5	3,7	= 410	900	0,41
10	7,4	= 830	1'830	0,83
15	11,0	= 1'250	2'760	1,25
20	14,8	= 1'650	3'640	1,65

PC2Z80L40PRG62	
1	1x TS170942
2	2x B210-62
3	2x TB150998
4	4x 8h6x80 DIN6325
5	4x 3h6x16 DIN6325
6	8x M4X8DIN913
7	2x PCS14
8	2x PCSP60R
9	2x PCSP60L
10	2x PCGU2049
11	2x M6X10ISO7380
kg	~4,7

### Weiche Backen zu Kompakter Zentrischspanner Soft jaws for compact self centering vise

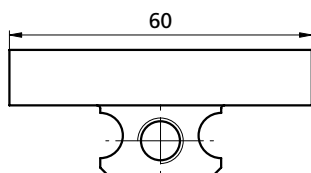

**B212W11-60\*** kg ~0,31  
H = 11 mm  
H1 = 6,5 mm

**H1: Zum Erstellen Ihrer individuellen Formbacke:**  
Schnittzeichnung zum Ermitteln der maximalen Bearbeitungsprofiltiefe

**H1: If a dedicated jaw is being machined:**  
Sectional drawing to determine the maximum machining depth

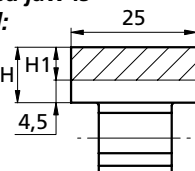

**B212W20-60\*** kg ~0,52  
H = 20 mm  
H1 = 15,5 mm

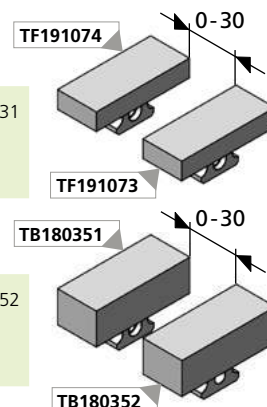

**WICHTIG!**  
Bitte separat bestellen!  
**IMPORTANT!**  
Please order separately!



Nuss 1/4 - sw 5,5



Bestellbeispiel / Ordering example: PC2Z80L40PRG62 & 1 x Nuss 1/4 - sw 5,5

\* = weich / soft (1.7225 Vergütungsstahl / Tempering steel)



Zwei Mini - Zentrischspanner mit Direktprägebacken halten verschieden lange Titanbleche. Um die verschiedenen Längen zu adaptieren, können die Spanner in 2 mm schritten seitlich versetzt werden.

Two mini - self centering vises with direct stamping jaws holding titanium sheets in different length. To adapt the different length's the vises can be moved side words in 2 mm steps.

Sondervorrichtung für Velo-Pedale mit dem schnellwechsel Nullpunkt-System OPP  
Dedicated fixture for high end bicycle pedals with quick change system OPP

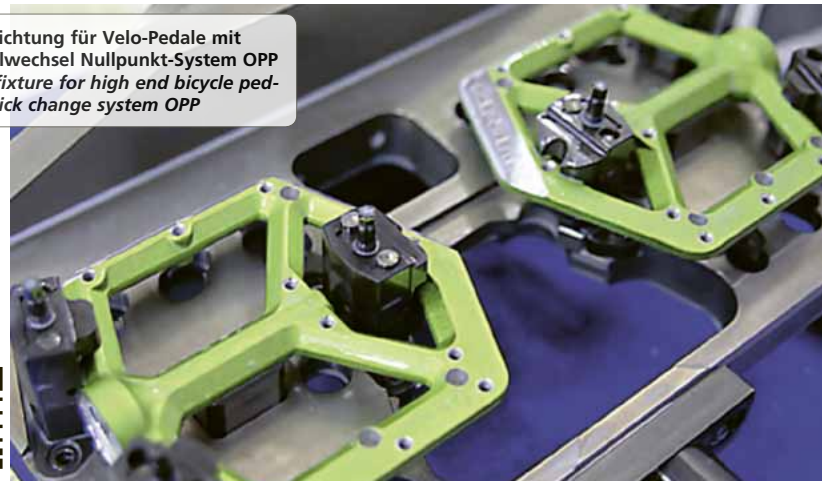

siehe Video  
see video





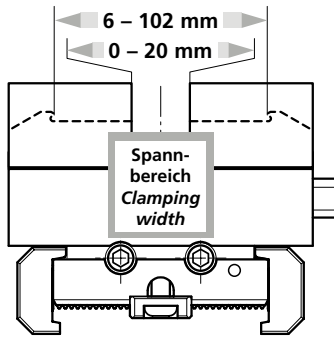
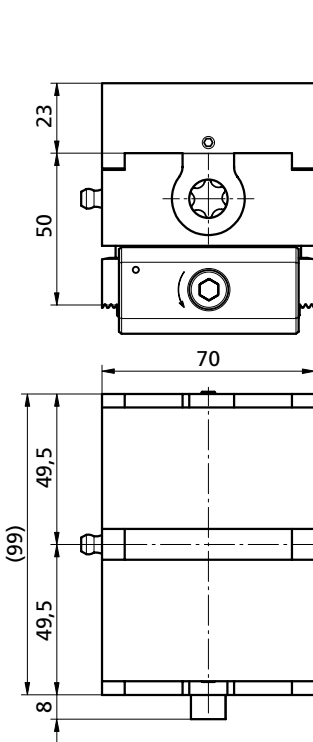

Drehmoment Torque		Spannkraft Workholding force		
Nm	(lb-ft)	~daN	~(lb)	~t
10	7,4	= 200	440	0,2
20	14,8	= 500	1'102	0,5
30	22,2	= 1'000	2'204	1,0
40	29,6	= 1'300	2'866	1,3
50	37,0	= 1'600	3'527	1,6

### Innenspannung-Set / Inner clamping set

Mit diesem Set ist es möglich das Werkstück von innen zu spannen. *With this set it is possible to clamp the workpiece from the inside.*

#### ACHTUNG / CAUTION

Folgende Spannbacken sind dazu nicht geeignet.

*The following clamping jaws are not suitable for this purpose.*

**B175-102, B175-121, B173-102**

**PCZS2439-ID-SET**

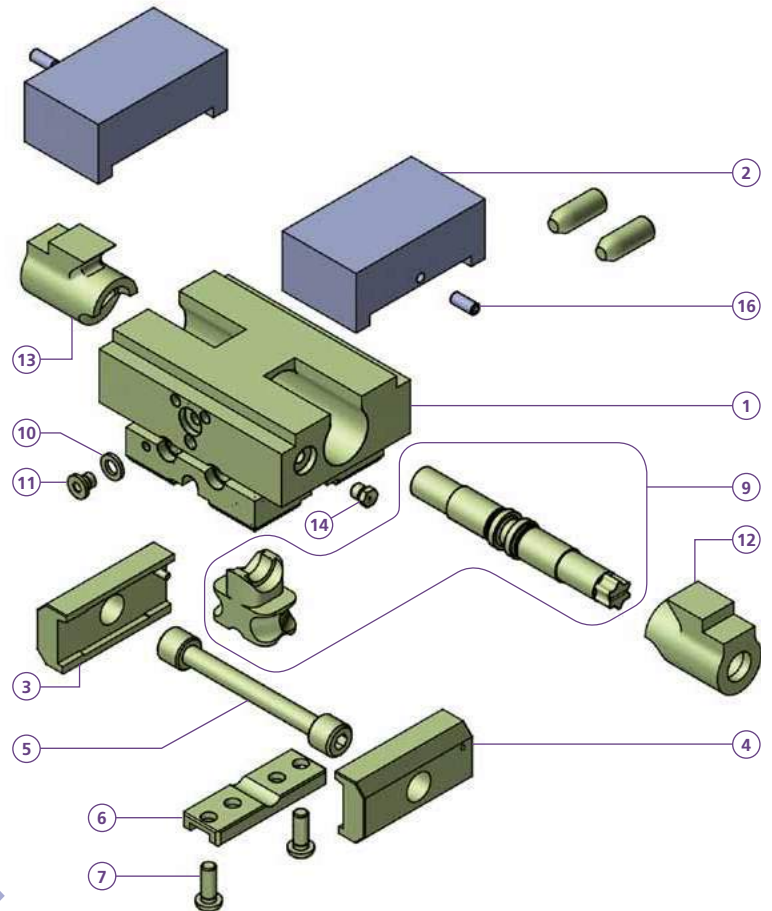
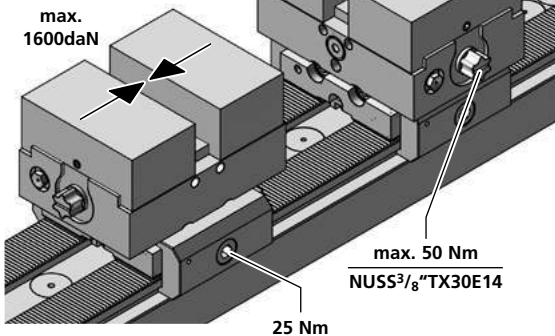
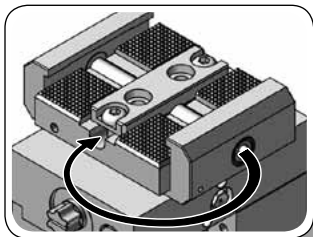
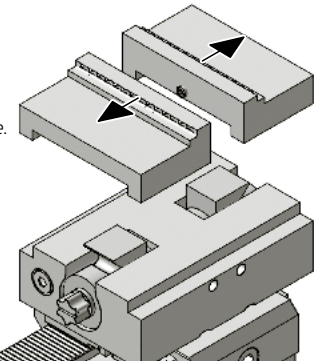

PCZ100L50	
1	1x PCZ100L50M
2	2x
3	1x PCSP60L
4	1x PCSP60R
5	1x PCS14
6	1x PCGUW20
7	2x M6X16ISO7380
9	1x PCS14M107SET
10	1x BN726 ISO 7092 M6
11	1x BN1206 M6x6
12	1x PCZS2439L
13	1x PCZS2439R
14	1x PCZSNP
15	4x PCZJ1025
16	2x TN100140
kg	~3,5

p. 128 - 129

**WICHTIG!**  
Bitte separat bestellen

**IMPORTANT!**  
Please order separately

NUSS3/8"TX30E14

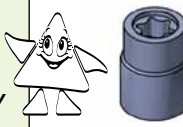

Bestellbeispiel / Ordering example:  
3 x PCZ100L50 & 6 x B170 & 1 x NUSS3/8"TX30E14



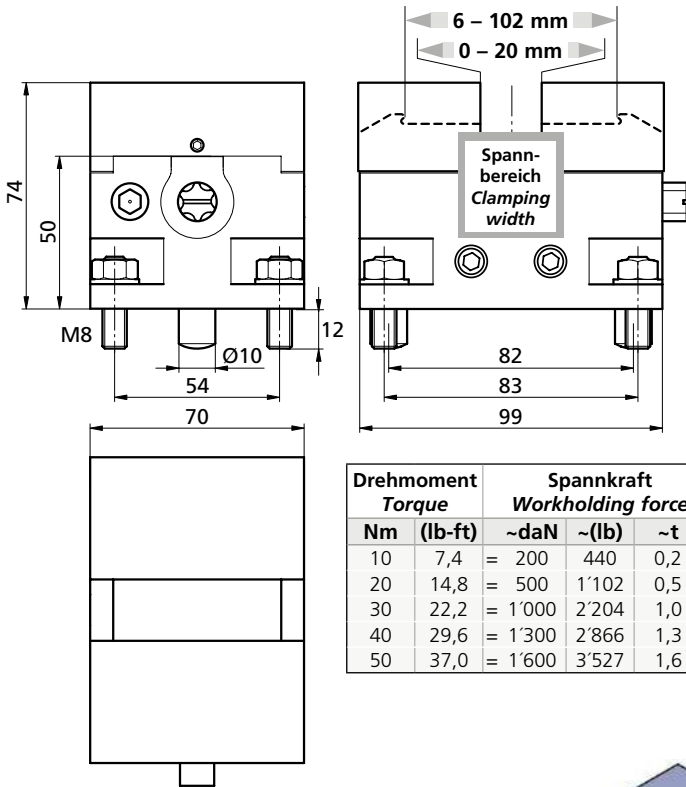

Drehmoment Torque		Spannkraft Workholding force		
Nm	(lb-ft)	~daN	~(lb)	~t
10	7,4	= 200	440	0,2
20	14,8	= 500	1'102	0,5
30	22,2	= 1'000	2'204	1,0
40	29,6	= 1'300	2'866	1,3
50	37,0	= 1'600	3'527	1,6

### Innenspannung-Set / Inner clamping set

Mit diesem Set ist es möglich das Werkstück von innen zu spannen. *With this set it is possible to clamp the workpiece from the inside.*

#### ACHTUNG / CAUTION

Folgende Spannbacken sind dazu nicht geeignet.

*The following clamping jaws are not suitable for this purpose.*

**B175-102, B175-121, B173-102**

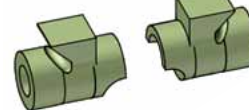

**PCZS2439-ID-SET**

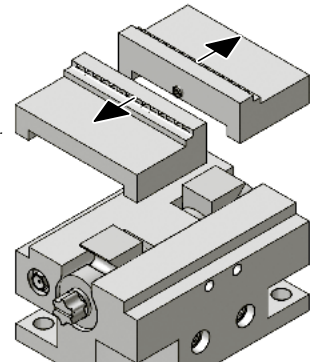

Nullpunkt des Zentrischspanners neu einstellen  
*How to readjust the zero point adjustment*

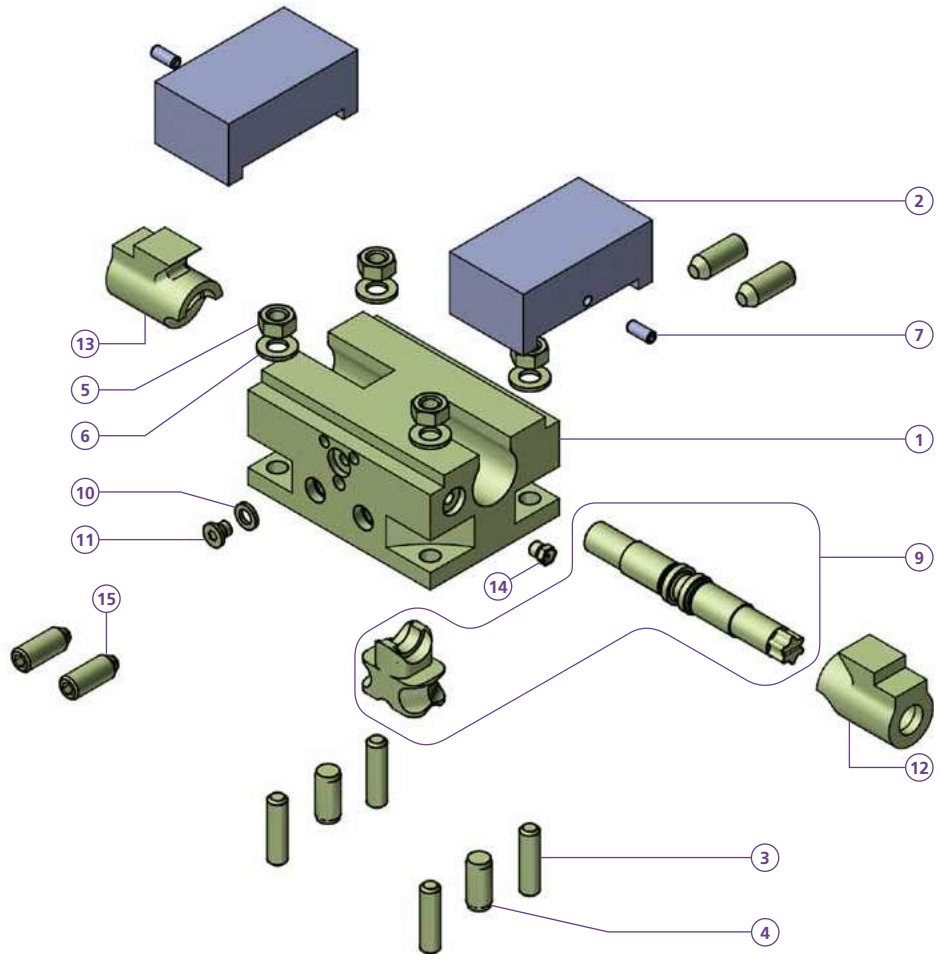
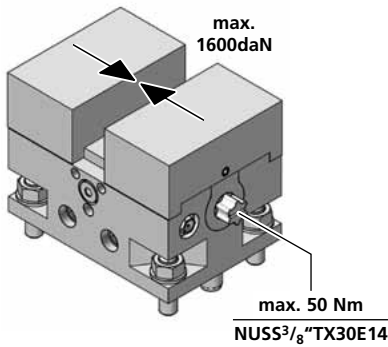

MCZ100L50	
1	1x MCZ100L50M
2	2x —
3	2x 10m6x22 ISO 8734
4	4x M8X30DIN913
5	4x M8 DIN 934
6	4x 8,4 DIN 125 A
7	2x TN100140
9	1x PCS14M107SET
10	1x BN726 ISO 7092 M6
11	1x BN1206 M6x6
12	1x PCZS2439L
13	1x PCZS2439R
14	1x PCZSNP
15	4x PCZJ1025
kg	~2,6

p. 128 - 129

**WICHTIG!**  
Bitte separat bestellen  
**IMPORTANT!**  
Please order separately

NUSS3/8"TX30E14



Bestellbeispiel / Ordering example:  
3 x MCZ100L50 & 6 x B170 & 1 x NUSS3/8"TX30E14

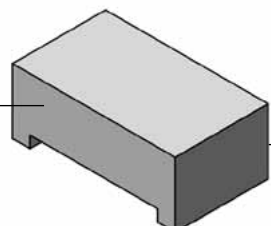
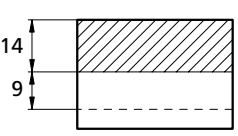
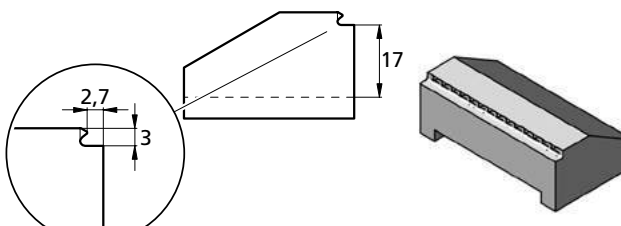
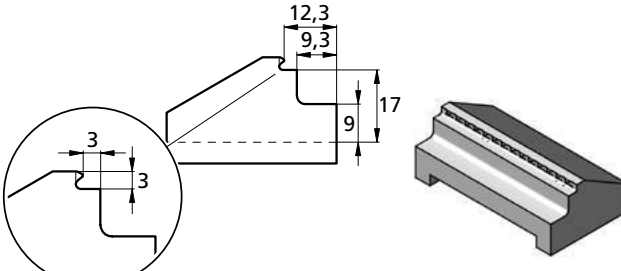
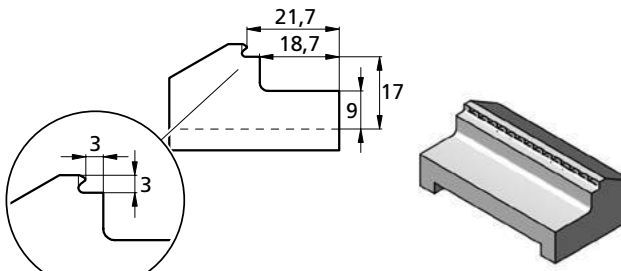
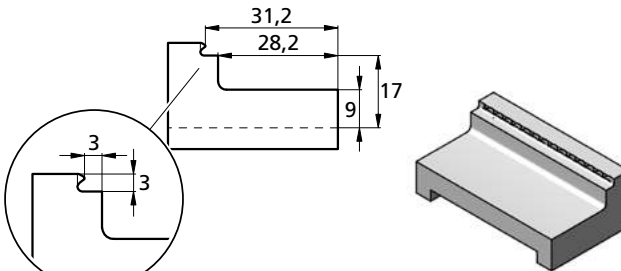
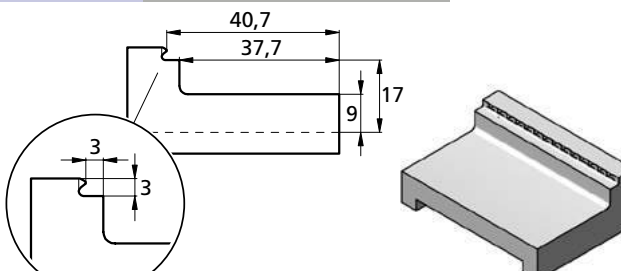
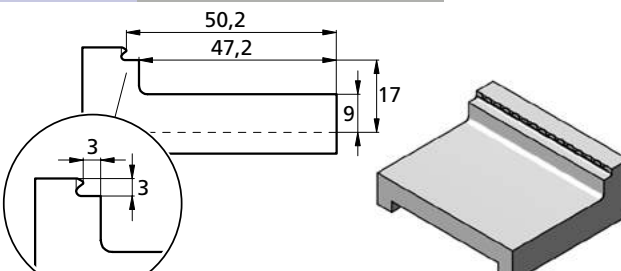

<p><b>B170, B172</b> Spannereich / Clamping width ◀ 0 – 20 mm ▶</p> <p>Zum Erstellen Ihrer individuellen Formbacke:                  Schnittzeichnung zum Ermitteln der maximalen Bearbeitungs-                  profiltiefe</p> <p><i>If a dedicated jaw is being machined:</i>                  Sectional drawing to determine the maximum machining depth</p>  <p>B170 HV700 x 0,2 mm</p> <p>B172</p> <p>weich soft 1.7225</p>  <p>für / for B170, B172</p>	
<p><b>B175-26</b> Spannereich / Clamping width ◀ 6 – 26 mm ▶</p> 	<p><b>B175-45</b> Spannereich / Clamping width ◀ 25 – 45 mm ▶</p> 
<p><b>B175-64</b> Spannereich / Clamping width ◀ 44 – 64 mm ▶</p> 	<p><b>B175-83</b> Spannereich / Clamping width ◀ 63 – 83 mm ▶</p> 
<p><b>B175-102</b> Spannereich / Clamping width ◀ 82 – 102 mm ▶</p> 	<p><b>B175-121</b> Spannereich / Clamping width ◀ 101 – 121 mm ▶</p> 

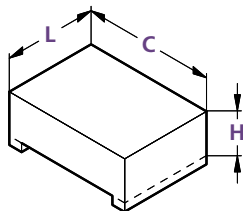

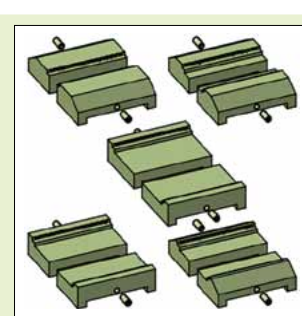
	B170	B172	B175-26	B175-45	B175-64	B175-83	B175-102	B175-121	B175SET
<b>B</b>									
<b>C</b>	70	70	70	70	70	70	70	70	2x B175-26
<b>H</b>	24	24	20	20	20	20	20	20	2x B175-45
<b>L</b>	40	40	40	40	40	40	50	60	2x B175-64
<b>i</b>	HV700	*	57HRC	57HRC	57HRC	57HRC	57HRC	57HRC	2x B175-83
	x0,2mm								2x B175-102
<b>kg</b>	~0,5	~0,5	~0,34	~0,29	~0,28	~0,25	~0,31	~0,37	

Bestellbeispiel / Ordering example: 2 x B170

Separat bestellen / Separate order



<p><b>B173-26</b> Spannereich / Clamping width ◀ 6 – 26 mm ▶</p>	<p><b>B173-45</b> Spannereich / Clamping width ◀ 25 – 45 mm ▶</p>
<p><b>B173-64</b> Spannereich / Clamping width ◀ 44 – 64 mm ▶</p>	<p><b>B173-83</b> Spannereich / Clamping width ◀ 63 – 83 mm ▶</p>
<p><b>B173-102</b> Spannereich / Clamping width ◀ 82 – 102 mm ▶</p>	<p><b>B176-80</b> Spannereich / Clamping width ◀ 8 – 80 mm ▶</p>
<p><b>ZK160798M5</b></p> <p><b>Extra Zubehör:</b>                  Schraube zum schnellen Wechseln der Backen</p> <p><b>Additional accessories:</b>                  Screw for quick change of jaws</p>	<p><b>PRG1003M8</b></p> <p><b>Bohrbild                  Hole pattern</b></p>

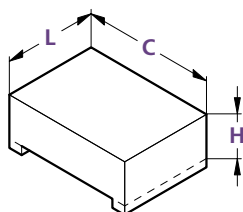

Bestellbeispiel / Ordering example: 2 x **B173-26**

	<b>B173-26</b>	<b>B173-45</b>	<b>B173-64</b>	<b>B173-83</b>	<b>B173-102</b>	<b>B176-80</b>	<b>B173SET</b>
<b>C</b>	70	70	70	70	70	70	2x <b>B173-26</b>
<b>H</b>	24	24	24	24	24	20	2x <b>B173-45</b>
<b>L</b>	40	40	40	40	50	40	2x <b>B173-64</b>
<b>i</b>	HV700	HV700	HV700	HV700	HV700	HV700	2x <b>B173-83</b>
	x0,2mm	x0,2mm	x0,2mm	x0,2mm	x0,2mm	x0,2mm	2x <b>B173-102</b>
<b>kg</b>	~0,31	~0,32	~0,32	~0,28	~0,34	~0,4	

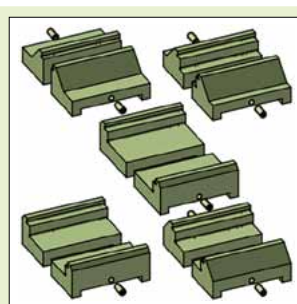

Separat bestellen / Separate order





#### Doppelt so spannend – doppelt so effizient

Die bewährten Zentrischspanner **PCZ100L50** und **MCZ100L50** sind nun auch als Doppelspanner erhältlich.

Im Doppelspanmodus können Bauteile im Spannbereich von 8 mm bis 43 mm mit den Standardbacken **B173-...** und **B175-...** gespannt werden.

#### Twice as clamping – twice as efficient

The proven self-centering vices **PCZ100L50** and **MCZ100L50** are now also available as dual clamping devices.

In the dual clamping mode, components can be clamped in the range from 8 mm to 43 mm with the standard jaws **B173-...** and **B175-...**

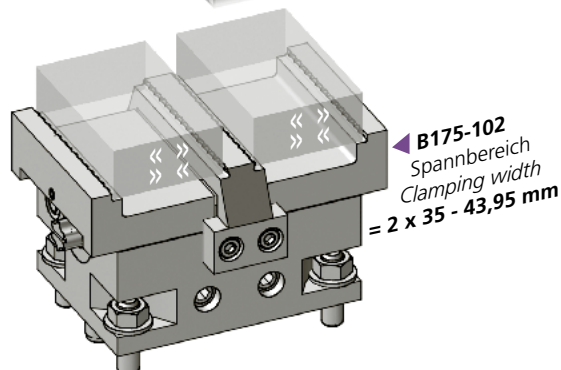
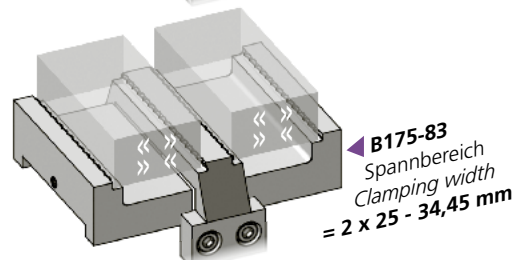
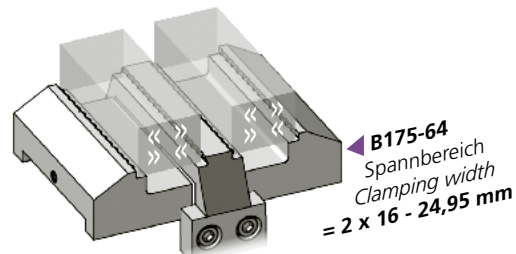
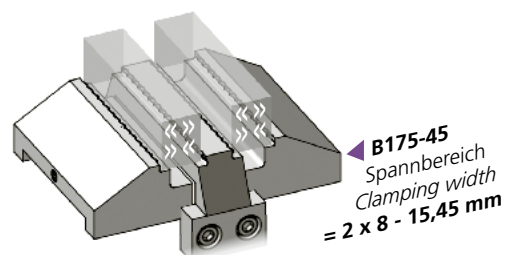
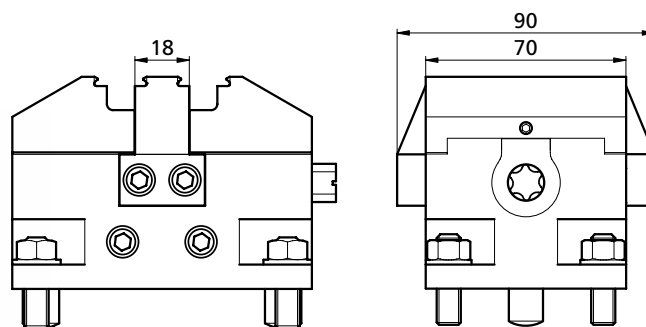
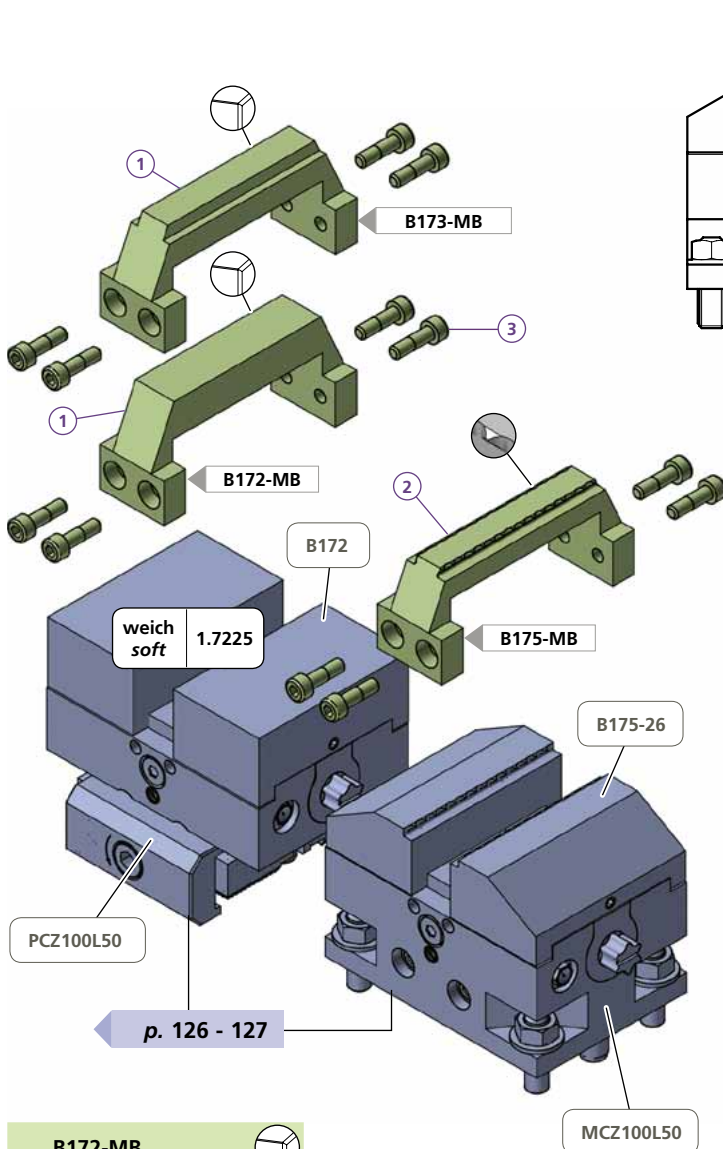

B172-MB	
1	1x TB190542
3	4x MS50
i	*
kg	~0,3

B173-MB	
1	1x TH160304
3	4x MS50
i	HV700x0,2
kg	~0,3

B175-MB	
2	1x TH160301
3	4x MS50
i	57HRC
kg	~0,3

Montageanleitung der Anschlagbrücke auf dem Mini-Zentrischspanner  
Operating instructions for this pneumatic self centering vise

Bestellbeispiel / Ordering example: **B172-MB** & 1 x **PCZ100L50**

\* = weich / soft (1.7225 Vergütungsstahl / Tempering steel)

Separat bestellen / Separate order

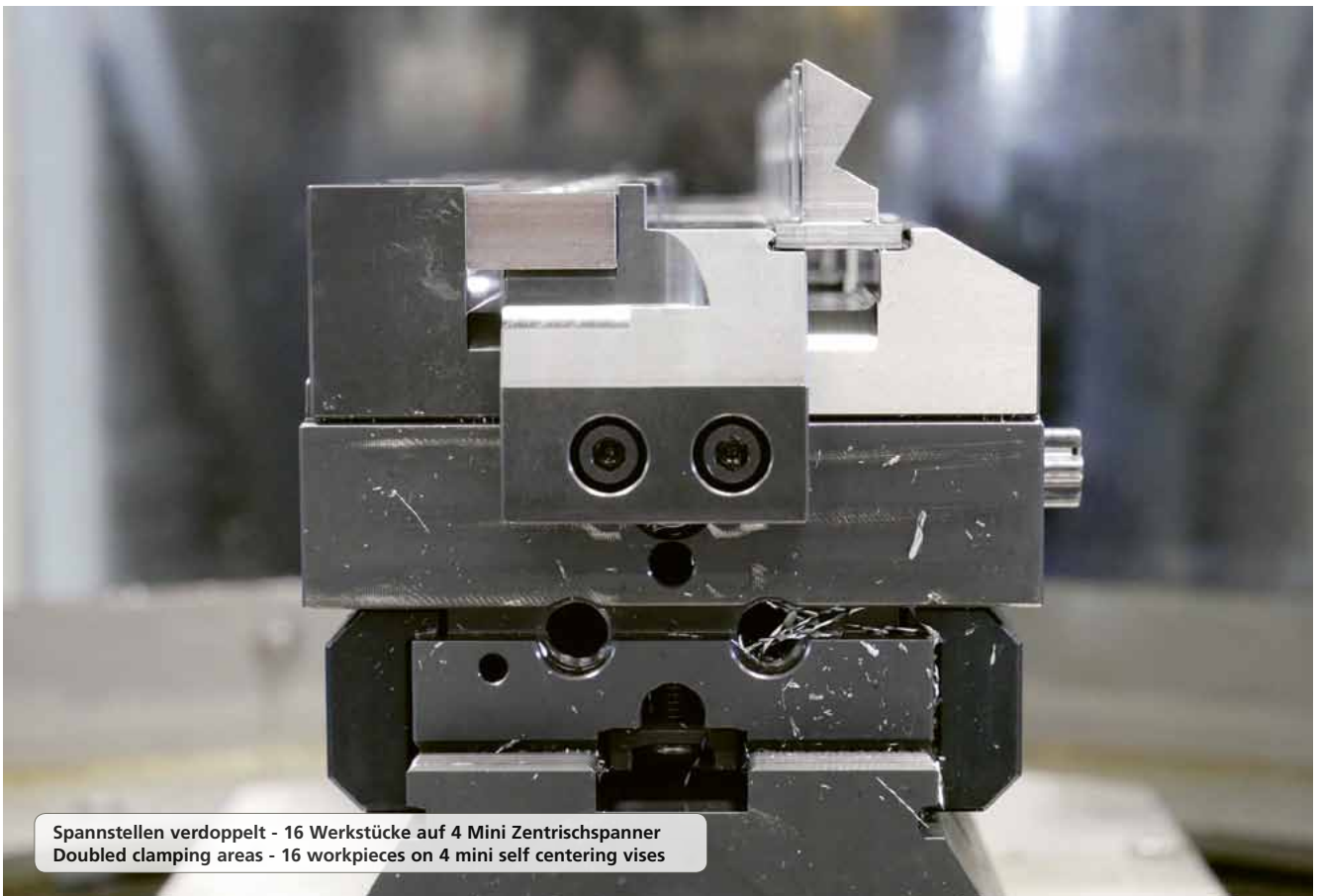
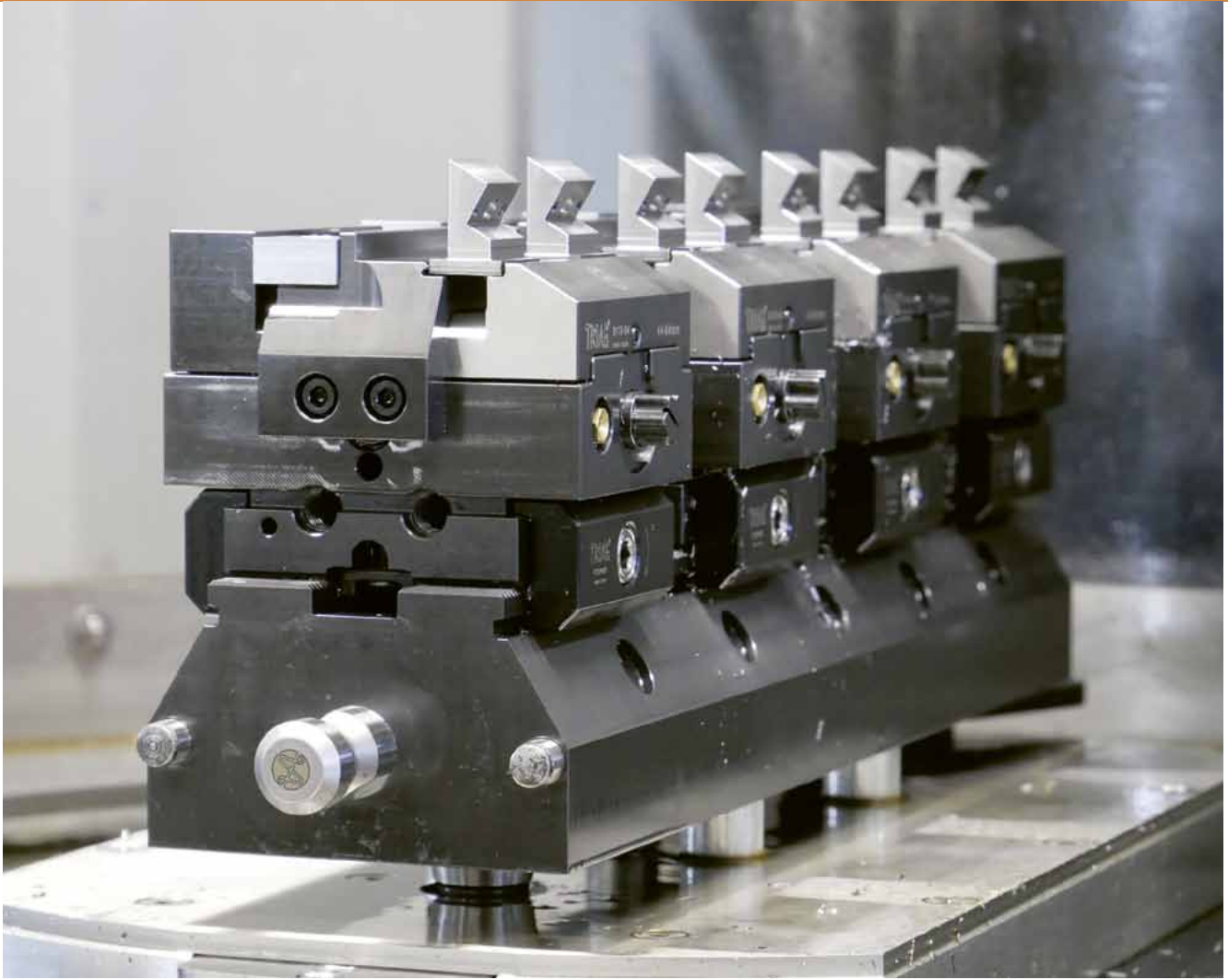

Spannstellen verdoppelt - 16 Werkstücke auf 4 Mini Zentrischspanner  
Doubled clamping areas - 16 workpieces on 4 mini self centering vises

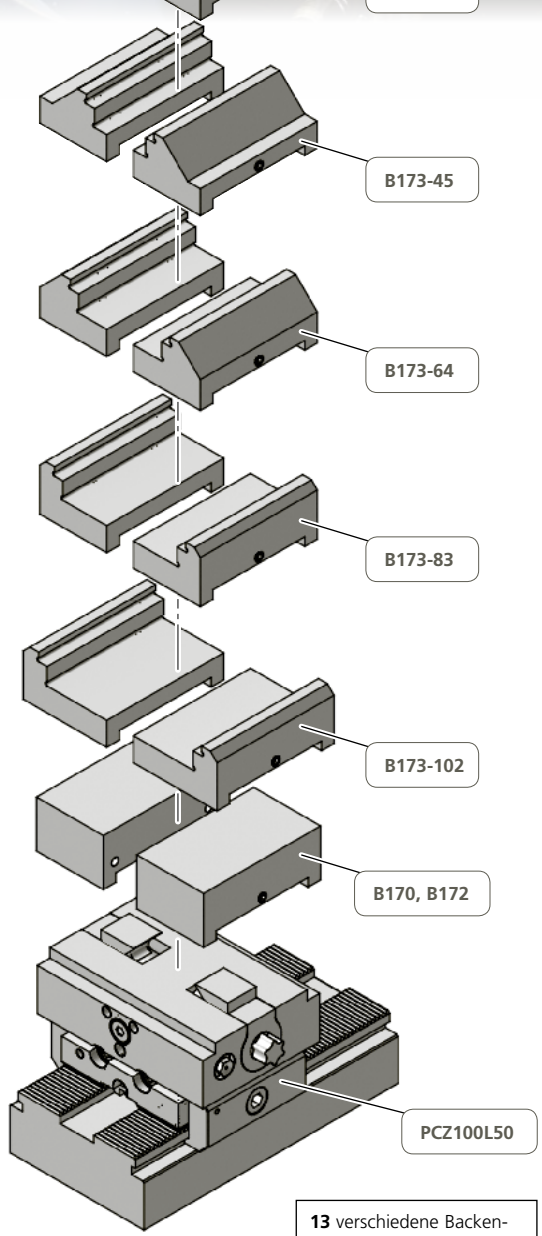
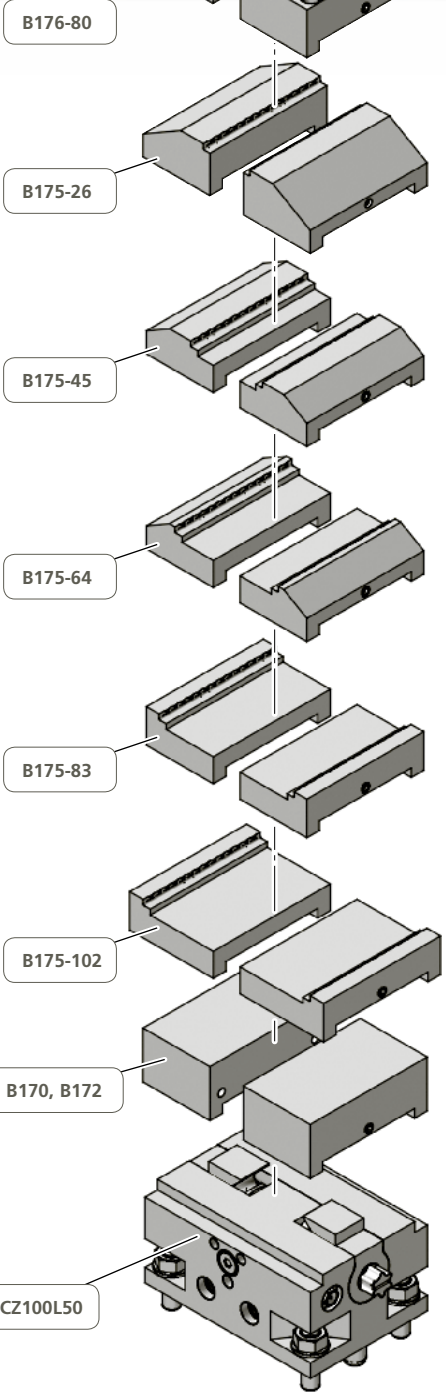

**13** verschiedene Backen-varianten passend zu dieser Schnellwechsell-schnittstelle.  
*More than 13 different jaw modules to match this rapidly changing interface.*





SPUTNIK II

**Sputnik II**

Ein einzigartig auf Modulbauweise ausgelegtes Spannkonzzept für den Einsatz der Zentrischspanner MCZ100L50.

Es können 4, 8 oder gar 12 Spanner, je nach Wunsch, eingesetzt werden. Das Ganze ist so modular wie ein «Lego»-Baukasten-System. Wieder stehen Prägebacken, weiche Backen und zusätzlich Stufen- und Universalbacken zur Verfügung. Sogar das Zentrum der einzelnen Spannstöcke kann eingestellt werden.

**Sputnik II**

A unique clamping concept with modular construction design for using the self-centering vice MCZ100L50.

Four, eight or even twelve clamping vices can be used as needed. The whole system is modular like a «Lego» building kit. Again, stamping jaws, soft jaws and universal as well as stepped jaws are available. Even the centre of the individual vices can be adjusted.

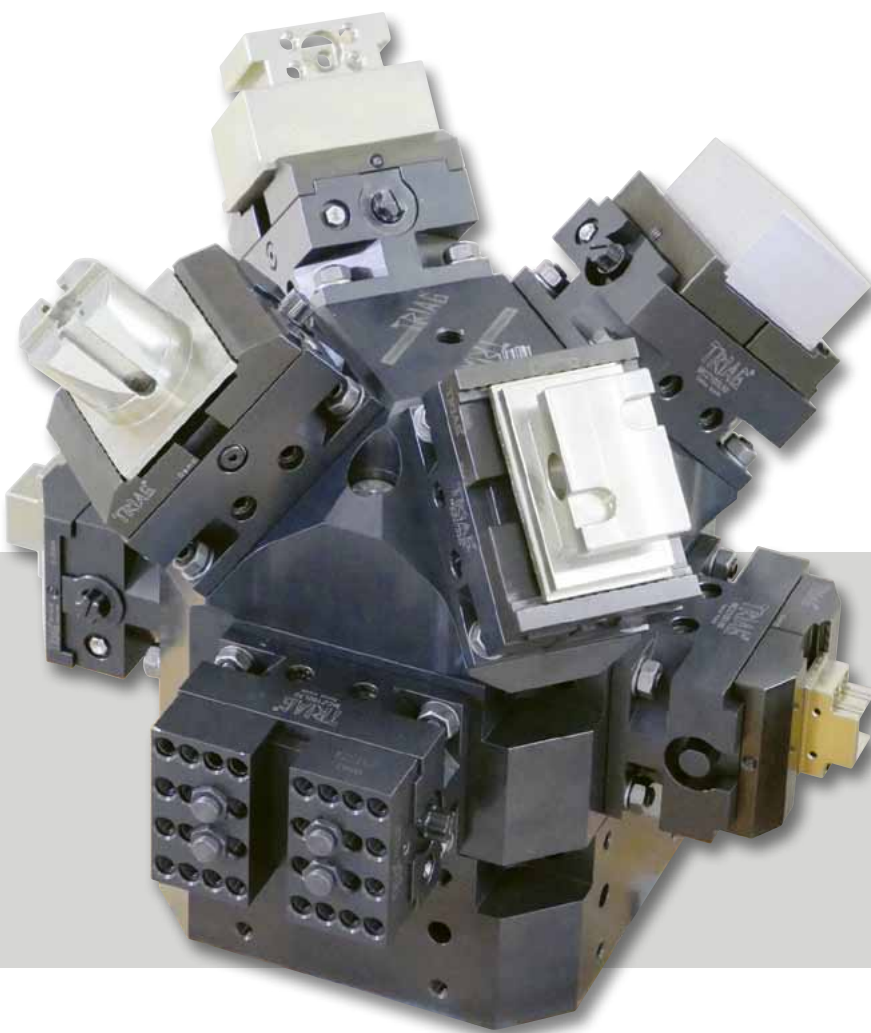

SPUTNIK II



SPUTNIK II

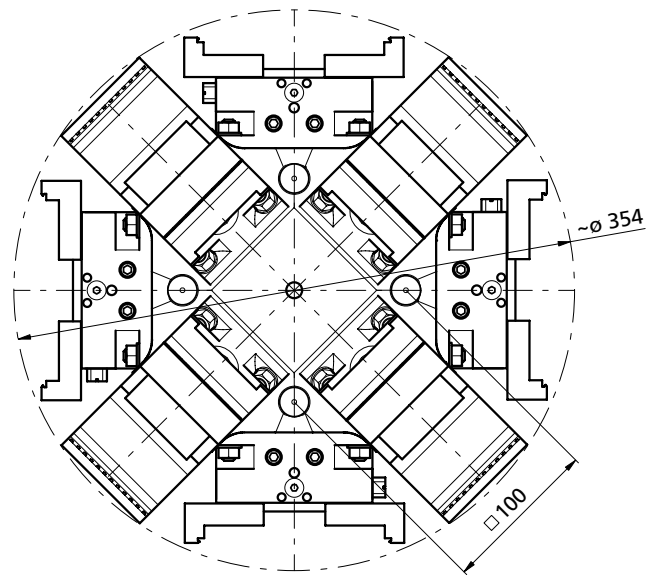
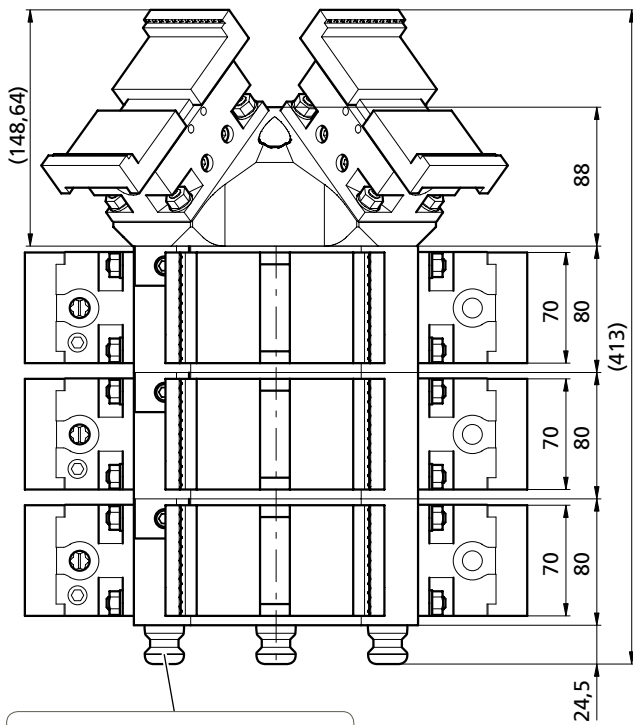

OPP-Schnittstelle Nullpunkt-System  
OPP interface Zero-point system

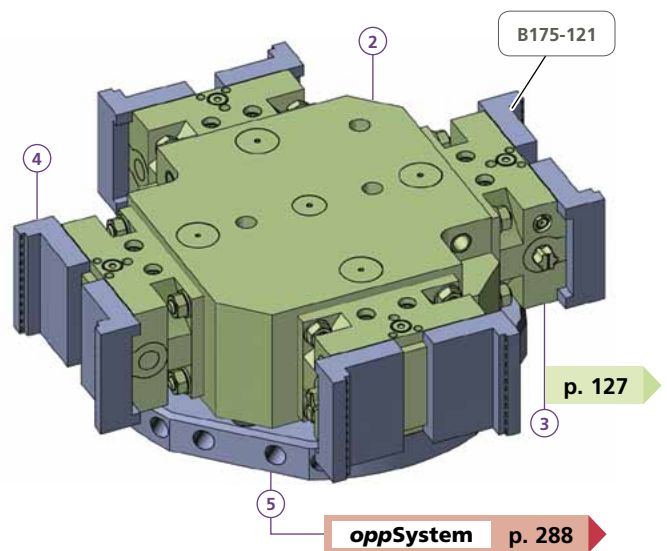
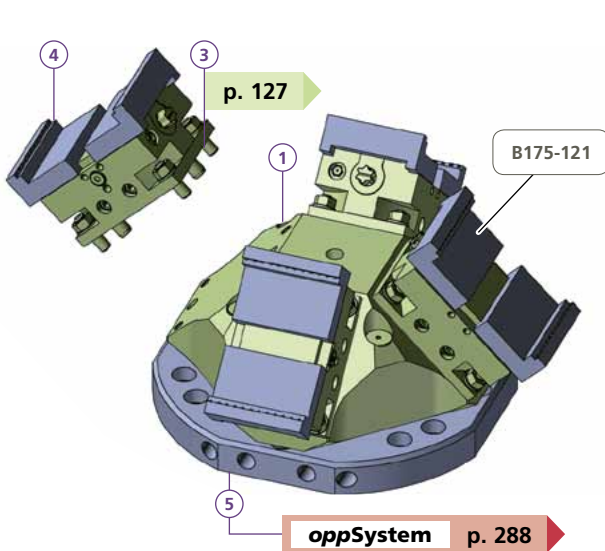

<b>5AXMCZ100-45-4</b>	
1	1x TS160110
3	4x MCZ100L50
4	8x ————— p. 128 - 129
5	1x TB160379
kg	~26



Detailzeichnung zu dieser Schnittstelle  
Detail drawing to interface

<b>5AXMCZ100-90-4</b>	
1	1x TS160111
3	4x MCZ100L50
4	8x ————— p. 128 - 129
5	1x TB160379
kg	~28,7



Detailzeichnung zu dieser Schnittstelle  
Detail drawing to interface

Bestellbeispiel / Ordering example : 1 x 5AXMCZ100-90-4 & 8 x B175-121



## SPUTNIK II

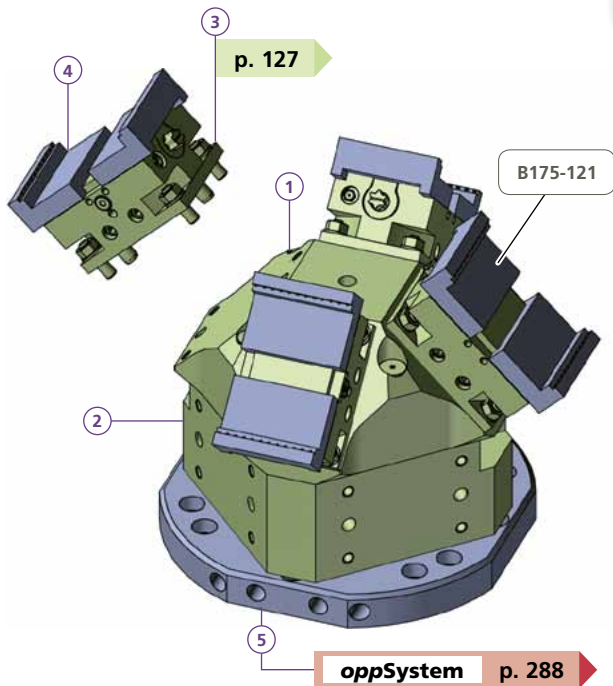

**5AXMCZ100-45-4H**

1	1x	TS160110
2	1x	TS160111
3	4x	MCZ100L50
4	8x	_____
5	1x	TB160379
kg		~41,2



Detailzeichnung zu dieser Schnittstelle  
Detail drawing to interface

p. 128 - 129

oppSystem p. 288

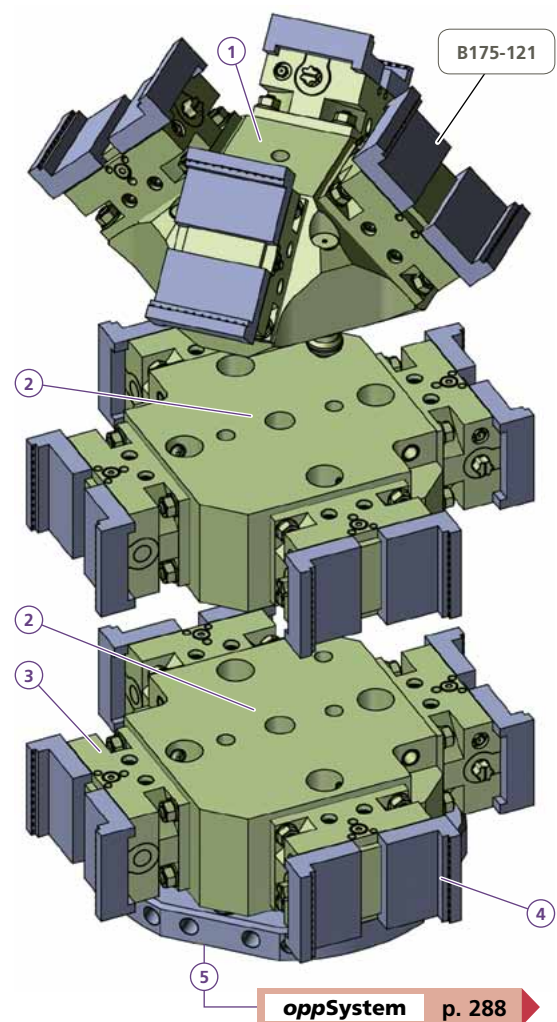

**5AXMCZ100-45-12**

1	2x	TS160110
2	1x	TS160111
3	12x	MCZ100L50
4	24x	_____
5	1x	TB160379
kg		~83,3



Detailzeichnung zu dieser Schnittstelle  
Detail drawing to interface

p. 128 - 129

oppSystem p. 288

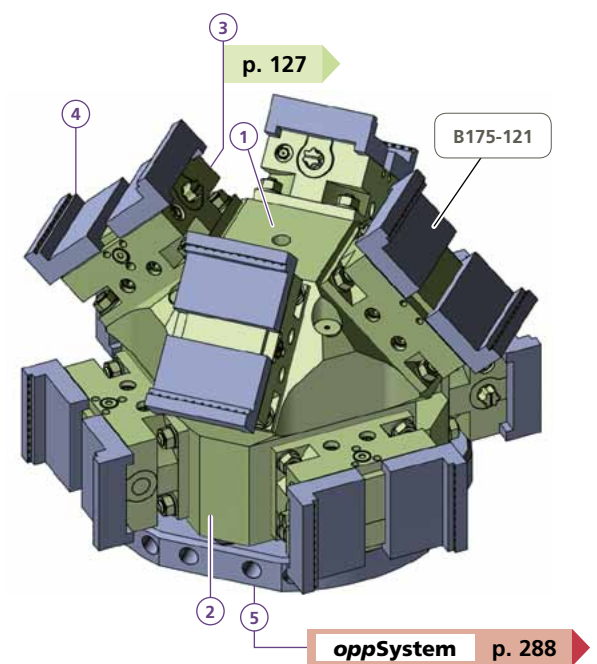

**5AXMCZ100-45-8**

1	1x	TS160110
2	1x	TS160111
3	8x	MCZ100L50
4	16x	_____
5	1x	TB160379
kg		~54,6



Detailzeichnung zu dieser Schnittstelle  
Detail drawing to interface

p. 128 - 129

oppSystem p. 288

Bestellbeispiel / Ordering example: 1 x 5AXMCZ100-45-8 & 16 x B175-121

Separat bestellen / Separate order



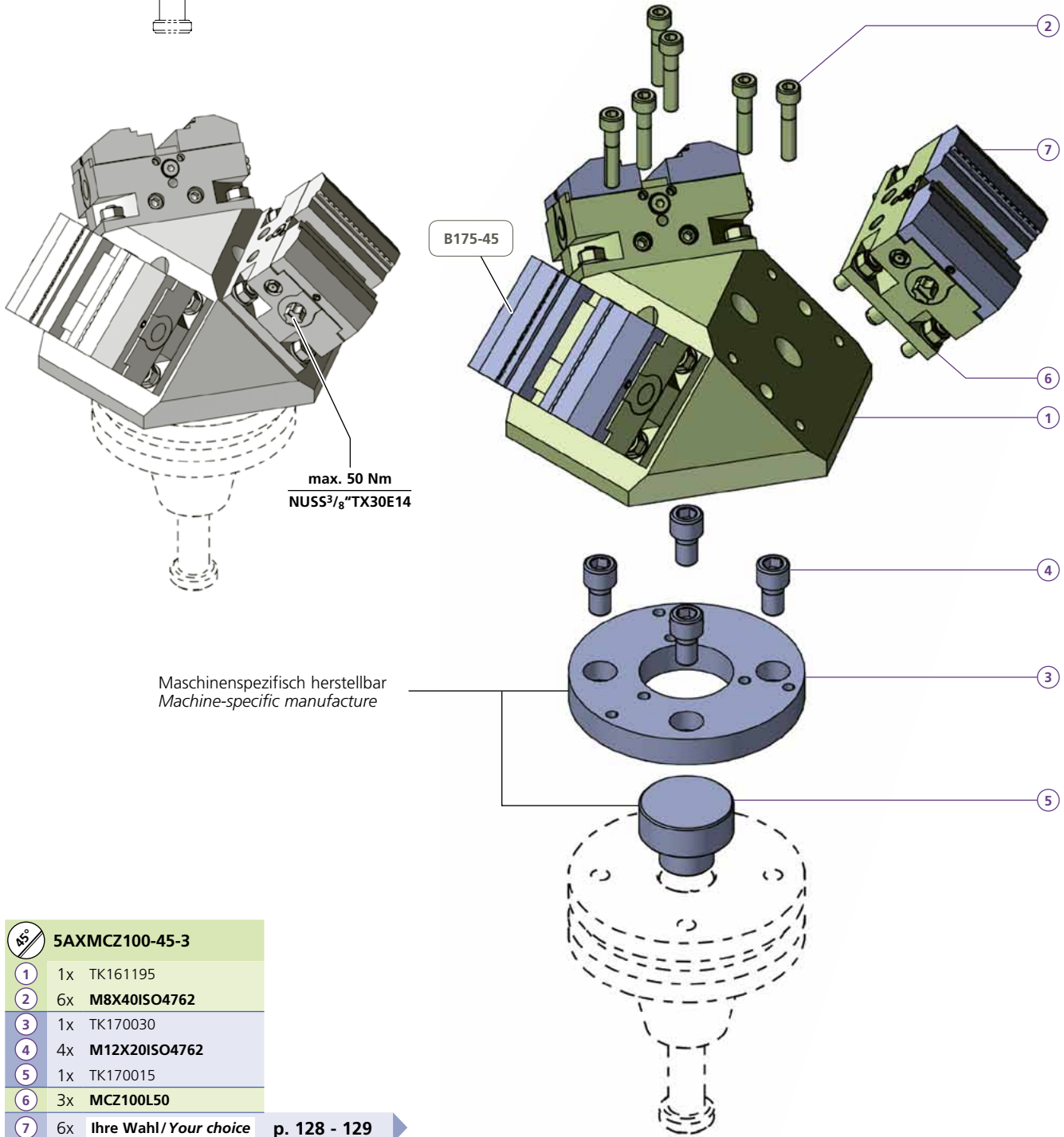
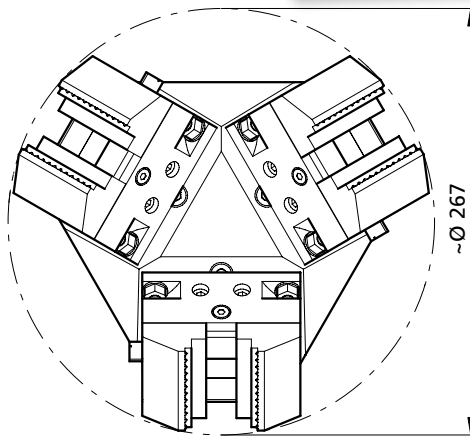
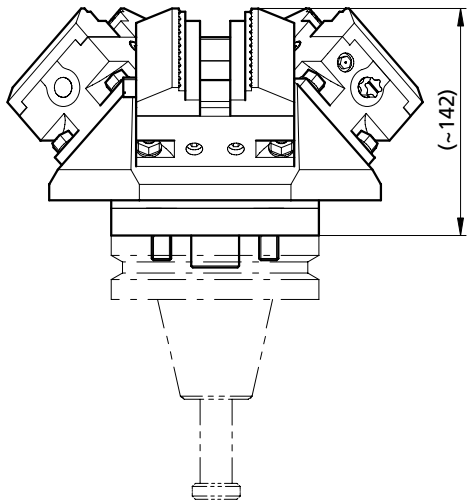

Maschinenspezifisch herstellbar  
Machine-specific manufacture

	<b>5AXMCZ100-45-3</b>
1	1x TK161195
2	6x <b>M8X40ISO4762</b>
3	1x TK170030
4	4x <b>M12X20ISO4762</b>
5	1x TK170015
6	3x <b>MCZ100L50</b>
7	6x Ihre Wahl / Your choice
kg	~27

p. 128 - 129

Bestellbeispiel / Ordering example:  
1 x 5AXMCZ100-45-3 & 6 x B175-45 & 1 x TK170030A & 4 x TN100291 & 1 x TK170015A

Separat bestellen / Separate order



**Durchgehend modular!**

Clevere Zentrischspanner passen sich der Maschine, den Werkstücken und den Anforderungen an.

**Constant modular!**

Clever self centering vise adapt to the machine, the workpiece and the requirements.

**X**

Spannkrafterhaltung  
und Nachfederung

Spring loaded  
mechanism to maintain  
clamping force

**M**

Mehr als 69 verschiedene  
Backenvarianten passend  
zu dieser Schnellwechsel-  
schnittstelle.

More than 69 different  
jaw modules to match this  
rapidly changing interface.

**B**

Mehr als 8 verschiedene  
Backenvarianten passend  
zu dieser Schnellwechsel-  
schnittstelle.

More than 8 different jaw  
modules to match this  
rapidly changing interface.

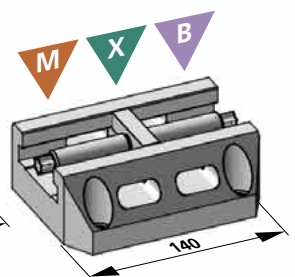
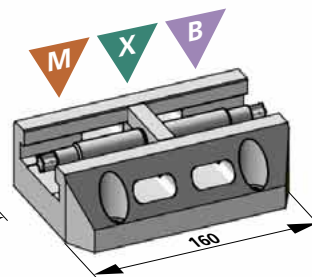
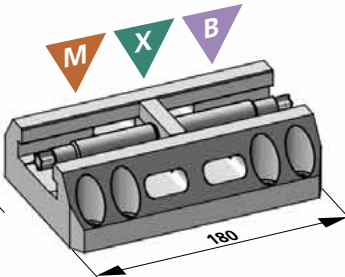
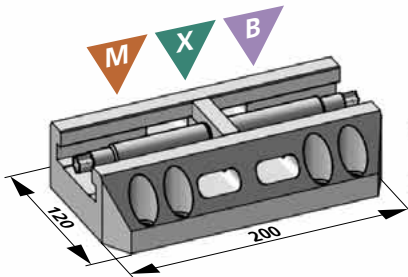
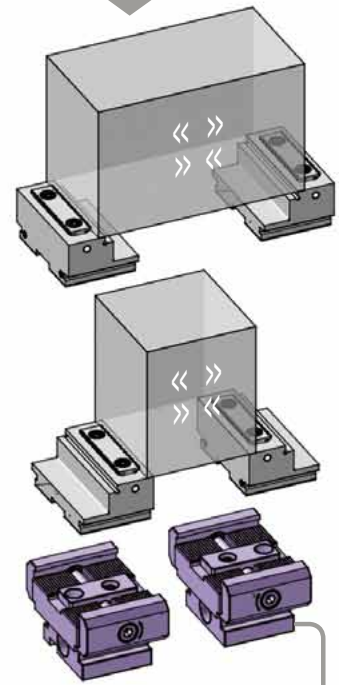
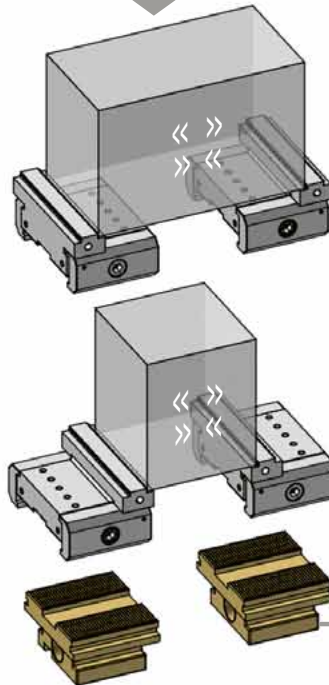
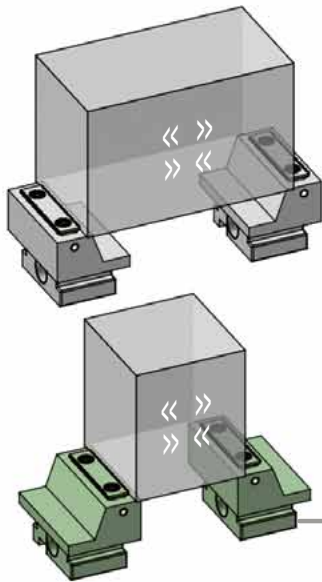

Bestellnummer Order number	kg
ZS X 200L50UPRG	~8,8
ZS X 180L50UPRG	~8,1
ZS X 160L50UPRG	~7,7
ZS X 140L50UPRG	~7,1

Bestellnummer Order number	kg
ZS M 200L50UPRG	~7,4
ZS M 180L50UPRG	~6,9
ZS M 160L50UPRG	~6,4
ZS M 140L50UPRG	~5,7

Bestellnummer Order number	kg
ZS B 200L50UPRG	~8,4
ZS B 180L50UPRG	~7,9
ZS B 160L50UPRG	~7,4
ZS B 140L50UPRG	~6,7



**Zentrischspanner mit Spannkrafterhaltung und Direkt-Prägebacken**

- ✓ für die erste Aufspannung mittels Direkt-Prägebacken ab 3 mm
- ✓ Einzigartiges integriertes Federpaket
- ✓ Beste Zugangs-Möglichkeit
- ✓ für OP10 und OP20 ausgelegt
- ✓ Bestens geeignet für 5-Achsen Maschinen mit kleinerem Tisch
- ✓ Bestens geeignet für den Einsatz auf Rundtischen

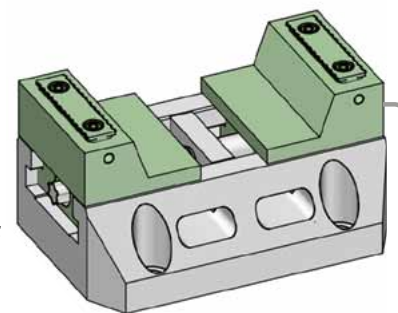

**Self-centering vise with spring loaded mechanism and direct stamping jaws**

- ✓ for the first clamping using direct stamping jaws from 3 mm
- ✓ Unique integrated spring package
- ✓ Best access option
- ✓ Designed for OP10 and OP20
- ✓ Ideally suited for 5-axis machines with smaller tables
- ✓ Ideally suited for use on rotary tables

**Zentrischspanner für den Einsatz mit Power Clamp Modulen**

- ✓ Höchste Modularität, alle Power Clamp Module können eingesetzt werden
- ✓ Schneller Backenwechsel (eine Schraube lösen und Modul nach oben abheben)
- ✓ Backen von 19 bis 150 mm
- ✓ weiche Backen
- ✓ Direktprägebacken und Bearbeitung ab 3 mm

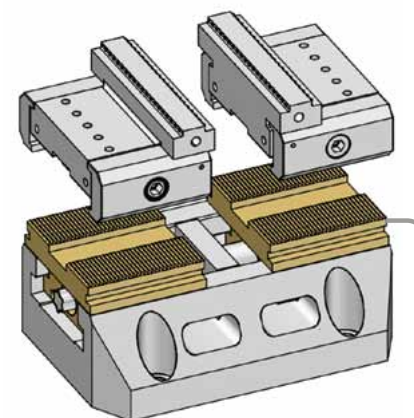

**Self-centering vice for use with Power Clamp modules**

- ✓ Highest modularity, all Power Clamp modules can be used
- ✓ Quick jaw change (loosen one screw and lift the module up)
- ✓ Jaws from 19 to 150 mm
- ✓ soft jaws
- ✓ Direct stamping jaws, machining from 3 mm

**Zentrischspanner für den Einsatz von Schnellwechselbacken**

- ✓ Hohe Backenvielfalt
- ✓ Weiche Backen zum selbst bearbeiten
- ✓ Direktprägebacken für OP10
- ✓ Schneller Backenwechsel (eine Schraube lösen, Backe nach oben abheben)
- ✓ Die Seitenbacken sind an den Schlitten montiert und müssen nicht jedes Mal mit den Backen gekauft werden

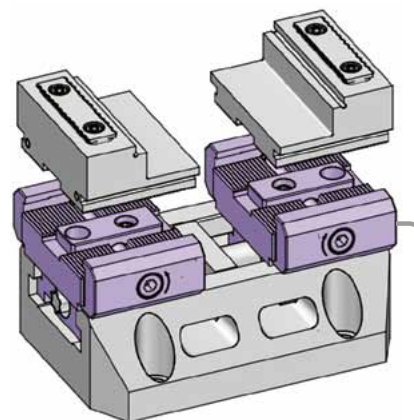

**Self-centering vice for the use of quick-change jaws**

- ✓ Great variety of jaws
- ✓ Soft jaws for individual machining
- ✓ Direct stamping jaws for OP10
- ✓ Quick jaw change (loosen one screw and lift the jaw up)
- ✓ The side clamps are integrated in the moving slides and must not be ordered with the jaws each time

Drehmoment Torque		Spannkraft Workholding force			Gut zu Wissen Good to know
Nm	(lb-ft)	~daN	~(lb)	~t	
10	7,4	= 200	440	0,2	Diese Spannkraften werden für den Dauerbetrieb empfohlen! These clamping forces are recommended for continuous operation!
20	14,8	= 500	1'102	0,5	
30	22,2	= 1'000	2'204	1,0	
40	29,6	= 1'300	2'866	1,3	
50	37,0	= 1'600	3'527	1,6	
60	44,4	= 1'800	3'968	1,8	Für kurzfristige Anwendung For short-term application
70	51,8	= 2'100	4'629	2,1	

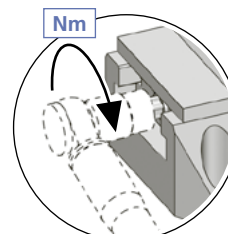





ZSM200L50 & PAND94-49PRG-A1





#### Direkt-Prägebacken

Bei knapp gespannten Werkstücken, speziell in weichen Materialien, wie Alu und Rostfrei aber auch in praktisch allen anderen Materialien, besteht das Problem, dass sich die Werkstücke freiwiegeln! Dies vor allem bei weit auskragenden Werkstücken bei der 5-Achsen Bearbeitung, selbst wenn vorgeprägt wird.

Triag International hat deshalb einen nachfedernden Zentrisch Spannstock entwickelt, welcher ein Freiwiegeln der Werkstücke mittels Nachfederung verhindert.

Bei diesem patentiertem System wird mittels Tellerfedern eine Backe des Zentrischspannstockes nachgeschoben. So wird der Spanndruck aufrechtgehalten. Die Einspanntiefe ist im Normalfall 3 mm, kann aber verstellt werden von ca. 1,8 bis 6 mm. Das Werkstück kann sich so praktisch nicht freiwiegeln.

Das heisst, man hat durchwegs die gleichen Bedingungen und das Werkstück hat während der Bearbeitung weniger Vibrationen und bewegt sich nicht. Oberfläche und Genauigkeit verbessern sich und sind konstanter.

#### Direct spring loaded stamping jaws

This patented self centering vise is unique, as it can be used for direct stamping the blanks. It is different to others as the teeth bite into the raw material and even under vibrations, one of the two jaws will continuously move forward. This will hold the workpiece with the same force and strength as in the beginning.

The problem in the past was that the other systems in the market were getting loose during heavy machining and accuracy was difficult to achieve.

Especially in soft materials such as alu and soft steels it has a great performance. Usually the workpiece is clamped only 3 mm but this height can be changed from 1,8 to 6 mm if necessary.

Spannkrafterhaltung und Nachfederung  
Spring loaded mechanism to maintain clamping force

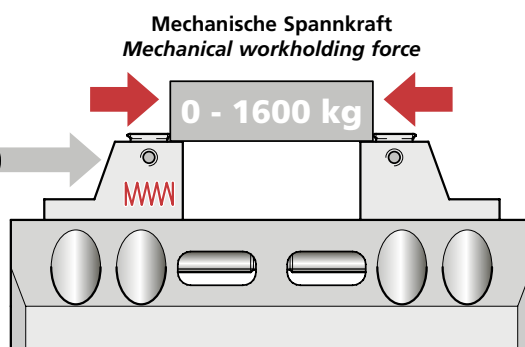

MANF58-14W25 microCLAMP p. 176

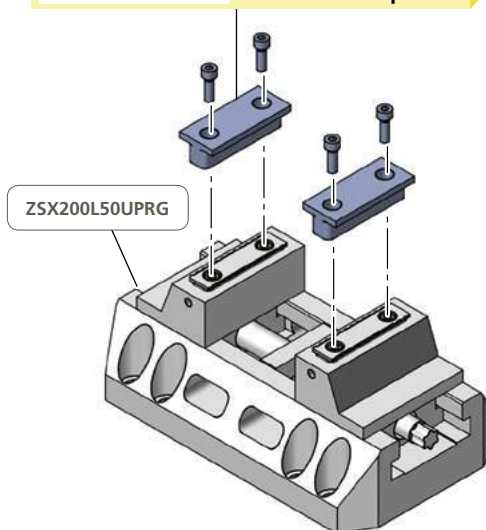

Drehmoment Torque		Spannkraft Workholding force			Gut zu Wissen Good to know
Nm	(lb-ft)	~daN	~(lb)	~t	
10	7,4	= 200	440	0,2	Diese Spannkräfte werden für den Dauerbetrieb empfohlen! <i>These clamping forces are recommended for continuous operation!</i>
20	14,8	= 500	1'102	0,5	
30	22,2	= 1'000	2'204	1,0	
40	29,6	= 1'300	2'866	1,3	
50	37,0	= 1'600	3'527	1,6	
60	44,4	= 1'800	3'968	1,8	Für kurzfristige Anwendung <i>For short-term application</i>
70	51,8	= 2'100	4'629	2,1	

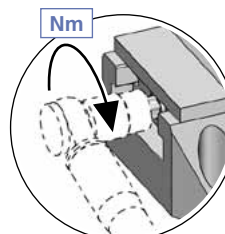

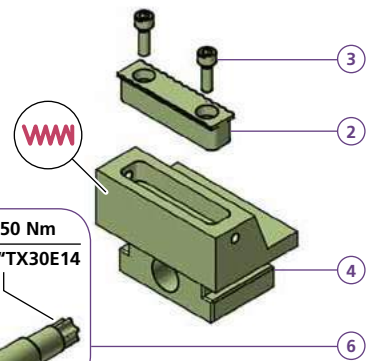
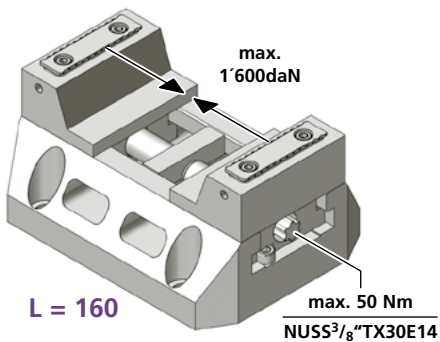
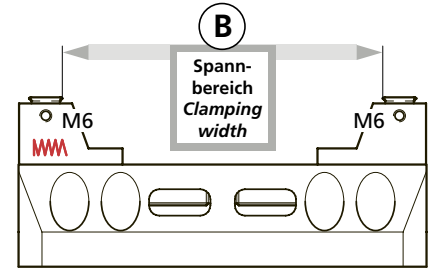
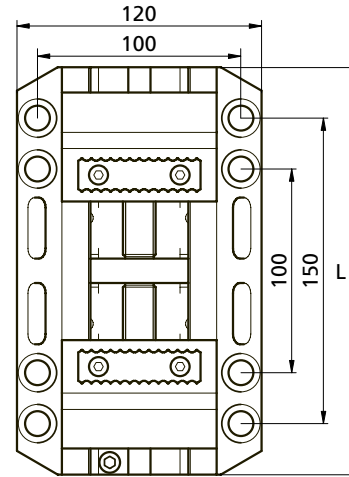
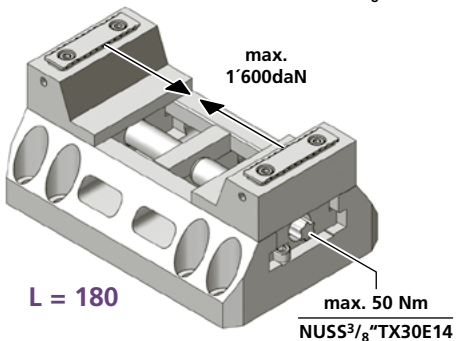
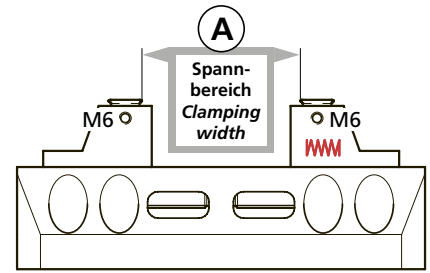
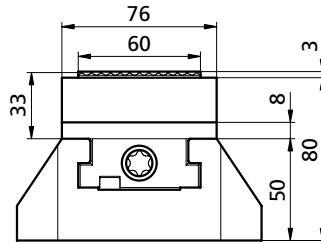
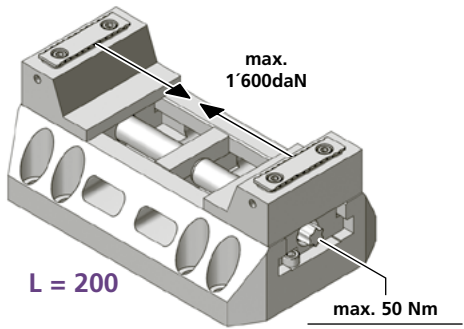

Spannkrafterhaltung und  
Nachfederung  
Spring loaded mechanism  
to maintain clamping force

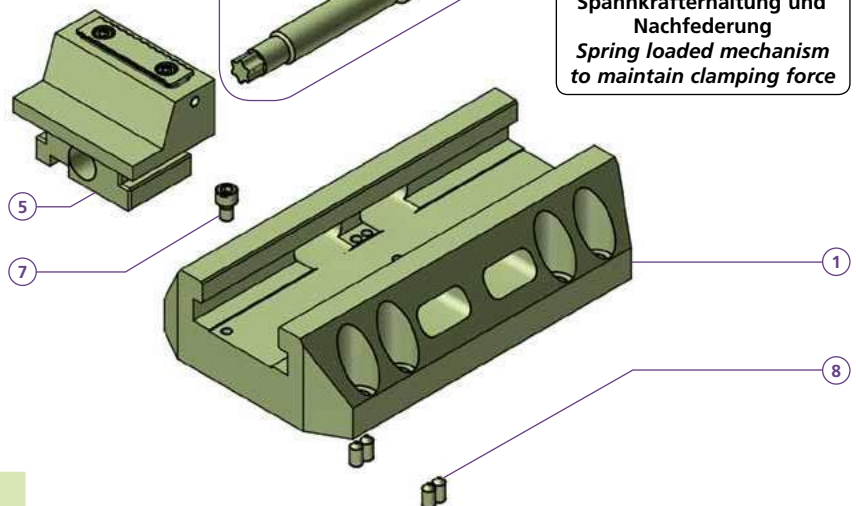
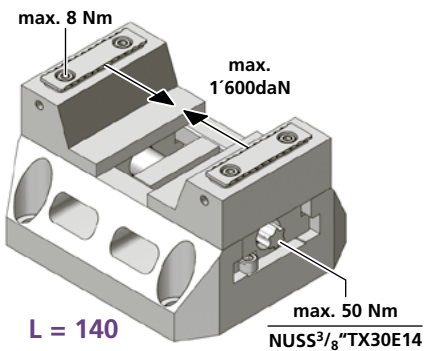

ZSX200L50UPRG	
1	1x TK150025
2	2x MAND58-14PRG
3	4x M5X16ISO4762
4	1x ZB150786
5	1x ZB150787
6	1x PCS16TR200SET
7	1x M6X10ISO4762
8	4x M6X16DIN914
L = 200	
A	10 – 124 mm
B	62 – 178 mm
kg	~8,8

ZSX180L50UPRG	
1	1x TK150523
6	1x PCS16TR180SET
L = 180	
A	10 – 104 mm
B	62 – 158 mm
kg	~8,1

ZSX160L50UPRG	
1	1x TK150522
6	1x PCS16TR160SET
L = 160	
A	10 – 84 mm
B	62 – 138 mm
kg	~7,7

ZSX140L50UPRG	
1	1x TK150521
6	1x PCS16TR140SET
L = 140	
A	10 – 64 mm
B	62 – 118 mm
kg	~7,1

Drehmoment und Spannkraft siehe Seite  
Torque and clamping force see page

140

**WICHTIG!**  
Bitte separat bestellen

**IMPORTANT!**  
Please order separately

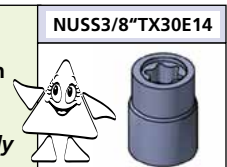

Bestellbeispiel / Ordering example:  
3 x ZSX200L50UPRG & 1 x NUSS3/8"TX30E14



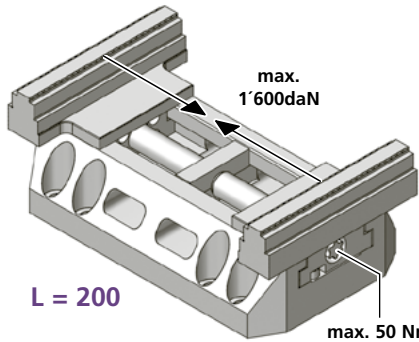

max. 50 Nm  
NUSS3/8"TX30E14

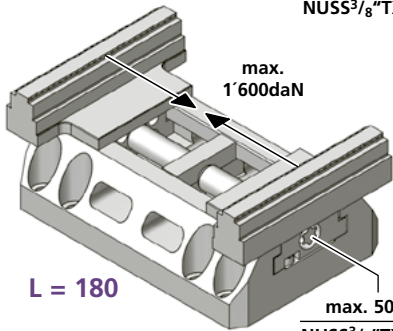

max. 50 Nm  
NUSS3/8"TX30E14

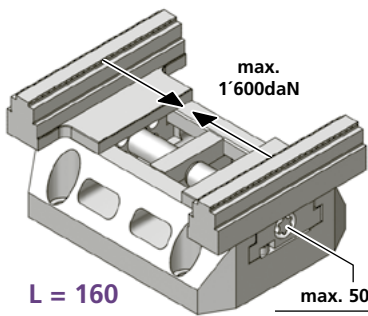

max. 50 Nm  
NUSS3/8"TX30E14

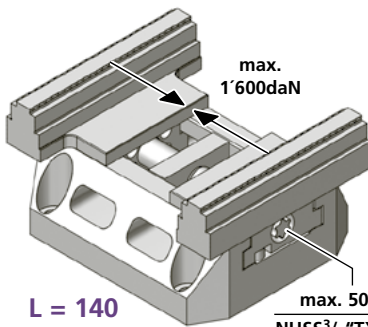

max. 50 Nm  
NUSS3/8"TX30E14

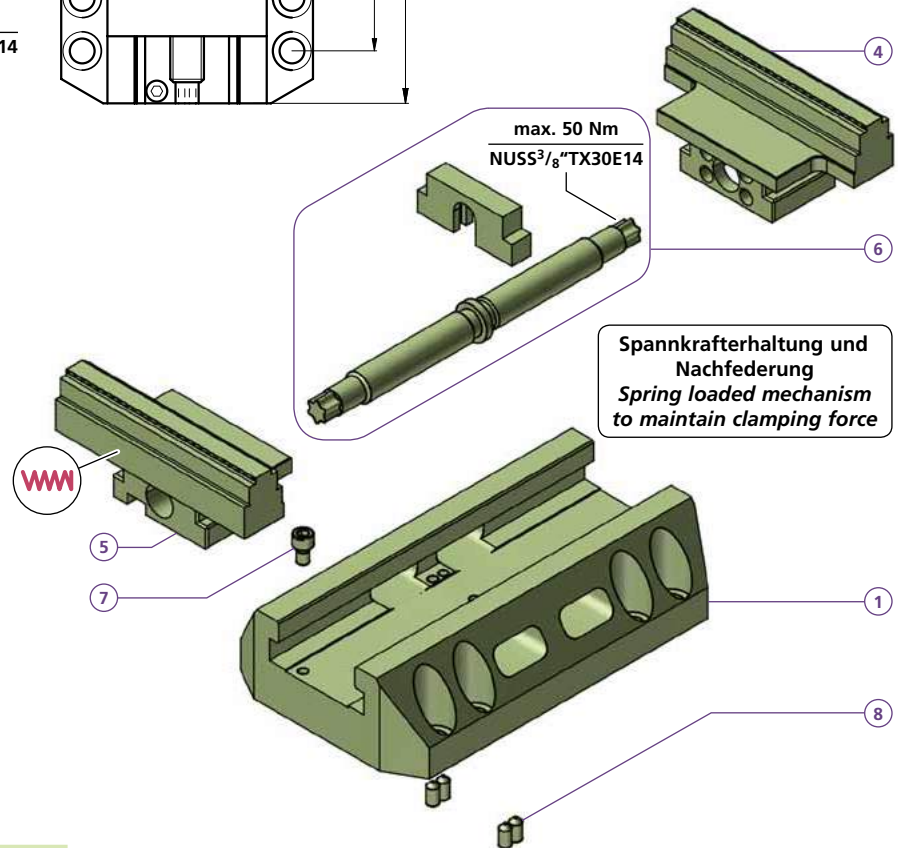
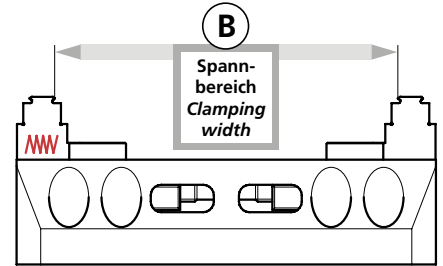
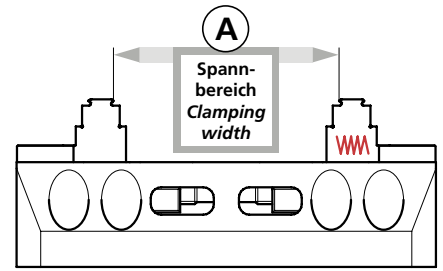
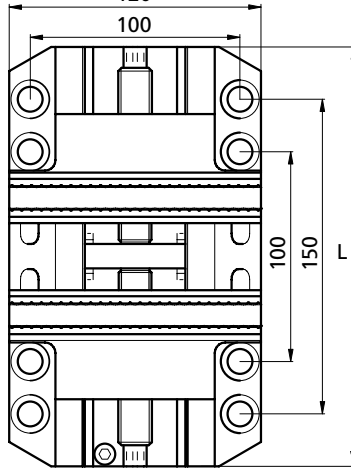
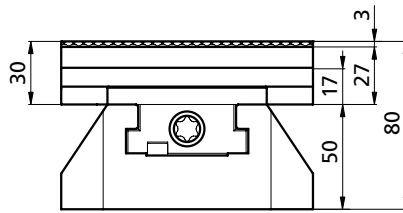

ZSX200L50PRG120	
1	1x TK150025
4	1x TB170051
5	1x ZB170050
6	1x PCS16TR200SET
7	1x M6X10ISO4762
8	4x M6X16DIN914
L	= 200
A	14 – 130 mm
B	70 – 186 mm
kg	~7,7

ZSX180L50PRG120	
1	1x TK150523
6	1x PCS16TR180SET
L	= 180
A	14 – 110 mm
B	70 – 166 mm
kg	~7,2

ZSX160L50PRG120	
1	1x TK150522
6	1x PCS16TR160SET
L	= 160
A	14 – 90 mm
B	70 – 146 mm
kg	~6,6

ZSX140L50PRG120	
1	1x TK150521
6	1x PCS16TR140SET
L	= 140
A	14 – 70 mm
B	70 – 126 mm
kg	~6,0

Drehmoment und Spannkraft siehe Seite  
Torque and clamping force see page 140

**WICHTIG!**  
Bitte separat bestellen  
**IMPORTANT!**  
Please order separately

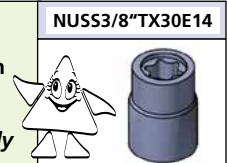

Bestellbeispiel / Ordering example:  
3 x ZSX200L50PRG120 & 1 x NUSS3/8"TX30E14



Drehmoment Torque		Spannkraft Workholding force			Gut zu Wissen Good to know
Nm	(lb-ft)	~daN	~(lb)	~t	
10	7,4	= 200	440	0,2	Diese Spannkraften werden für den Dauerbetrieb empfohlen! <i>These clamping forces are recommended for continuous operation!</i>
20	14,8	= 500	1'102	0,5	
30	22,2	= 1'000	2'204	1,0	
40	29,6	= 1'300	2'866	1,3	
50	37,0	= 1'600	3'527	1,6	
60	44,4	= 1'800	3'968	1,8	Für kurzfristige Anwendung <i>For short-term application</i>
70	51,8	= 2'100	4'629	2,1	

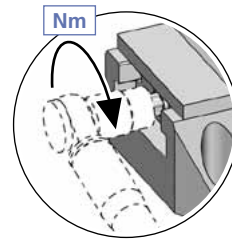

NEWS →

PowerCLAMP

Anschlagmodul mit Prägeeinsätzen  
End modul with embossed inserts

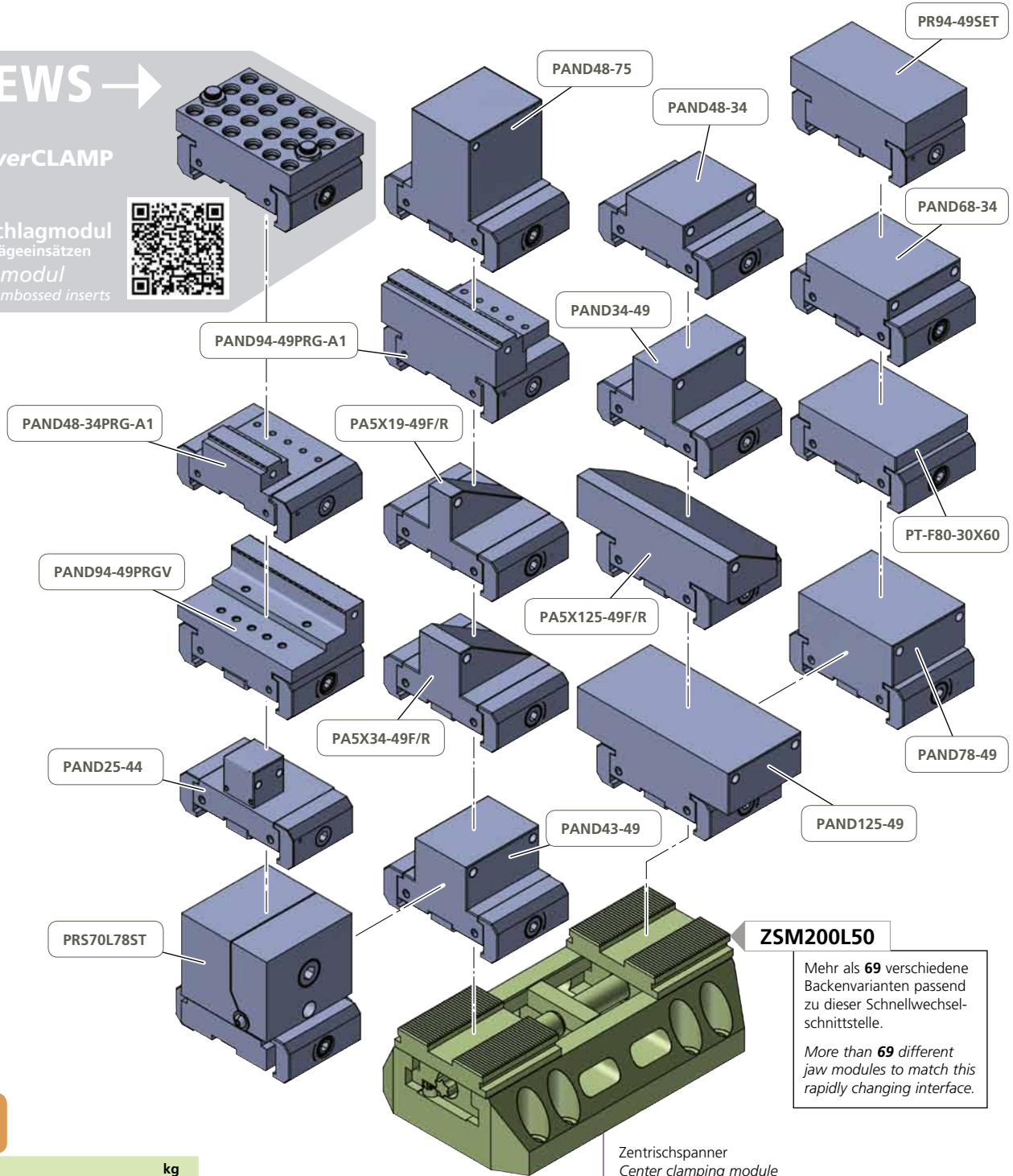

ZSM200L50

Mehr als 69 verschiedene Backenvarianten passend zu dieser Schnellwechelschnittstelle.

More than 69 different jaw modules to match this rapidly changing interface.



	kg
1 ZSM200L50	~5,6
ZSM180L50	~5,0
ZSM160L50	~4,5
ZSM140L50	~4,0
2x	

powerCLAMP p. 85 - 96

Bestellbeispiel / Ordering example: 1 x ZSM200L50 & 2 x PAND94-49PRG-A1

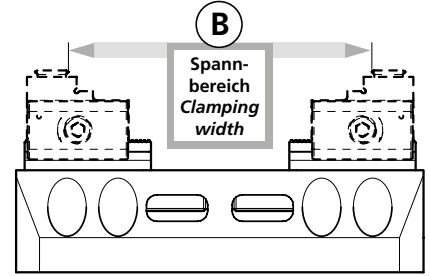
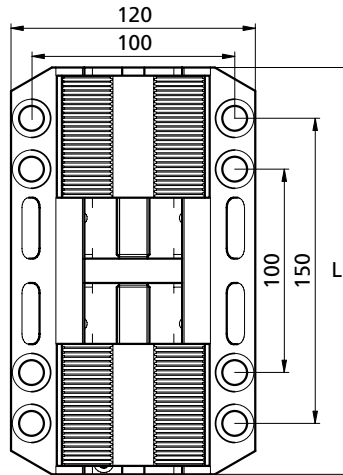
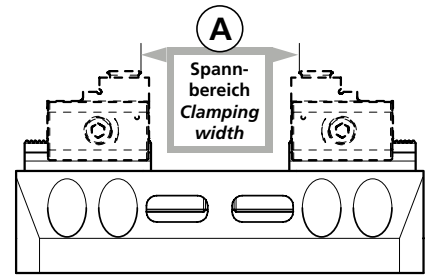
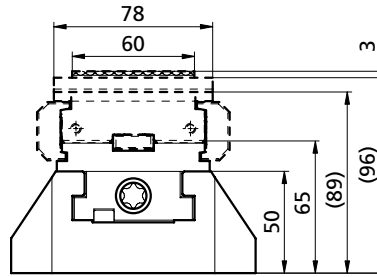
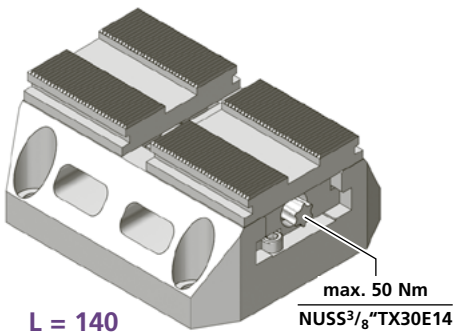
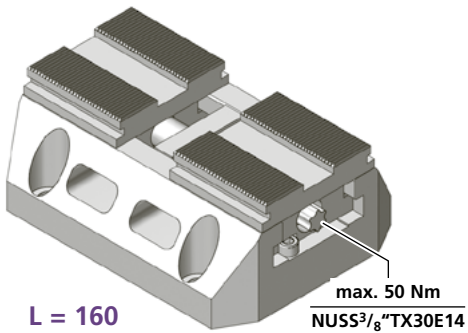
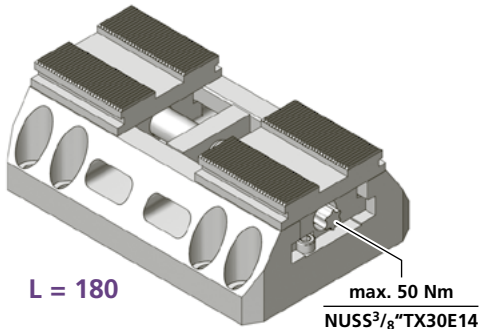
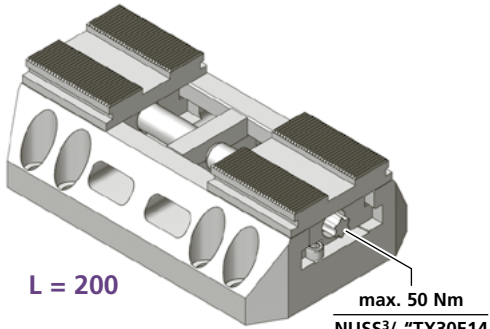

PAND78-34UPRG powerCLAMP p. 92

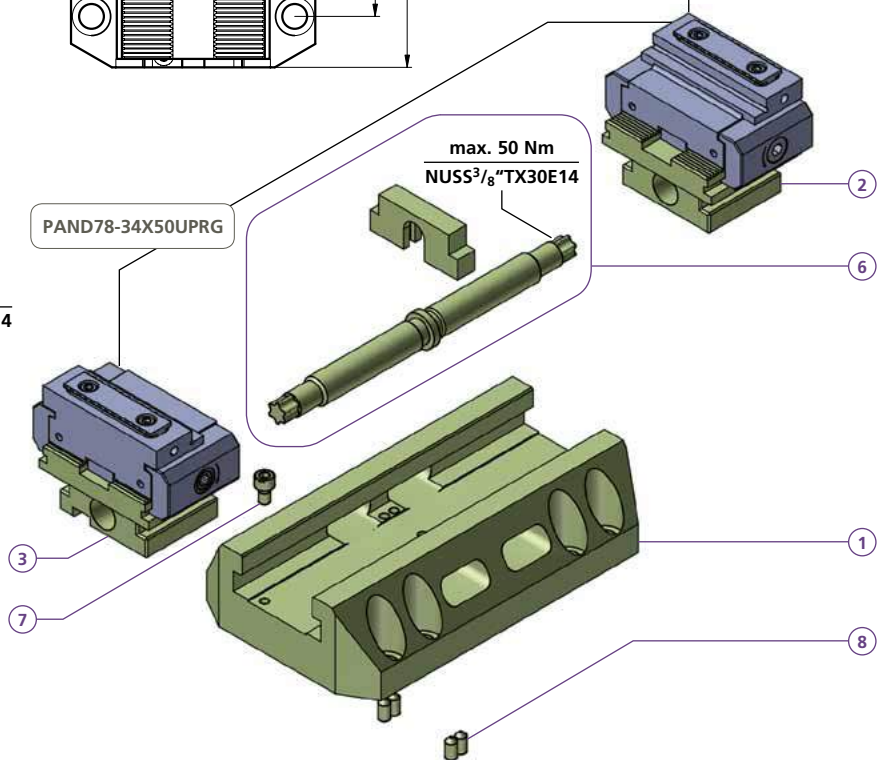

ZSM200L50	
1	1x TK150025
2	1x TB150092
3	1x TB150091
6	1x PCS16TR200SET
7	1x M6X10ISO4762
8	4x M6X16DIN914
L	= 200
A	10 – 124 mm
B	60 – 175 mm
kg	~7,4

ZSM180L50	
1	1x TK150523
6	1x PCS16TR180SET
L	= 180
A	10 – 104 mm
B	60 – 155 mm
kg	~6,9
ZSM160L50	
1	1x TK150522
6	1x PCS16TR160SET
L	= 160
A	10 – 84 mm
B	60 – 135 mm
kg	~6,4

ZSM140L50	
1	1x TK150521
6	1x PCS16TR140SET
L	= 140
A	10 – 64 mm
B	60 – 115 mm
kg	~5,7

Drehmoment und Spannkraft siehe Seite 143  
Torque and clamping force see page 143

**WICHTIG!**  
Bitte separat bestellen

**IMPORTANT!**  
Please order separately

Bestellbeispiel / Ordering example:  
3 x ZSM200L50 & 6 x (PAND78-34X50UPRG)  
& 1 x NUS3/8"TX30E14





### Seitlich verstellbarer Zentrischspannstock

Passend auf alle Power Clamp Basisschienen können mehrere dieser Zentrischspanner, seitlich aneinander gereiht, lange Werkstücke spannen und sind dabei flexibel in 2 mm Schritten seitlich verschiebbar.

Auch können diese für Mehrfachspannung genutzt werden und mehrere Einzelteile an fixen Punkten gespannt werden.

Einsatzgebiet für lange Profile, Stangen und Bleche aber auch Mehrfachspannung von fast allen Materialien.

### Laterally adjustable centric vise

Fitting all Power Clamp basic rails, several of these self-centering vices can, arranged laterally in rows, clamp long work pieces and can hereby be flexibly shifted sideways in 2 mm steps.

They can also be used for multi clamping and several individual parts clamped at fixed points.

The field of application for long sections, rods and sheets but also multi clamping of almost all materials.

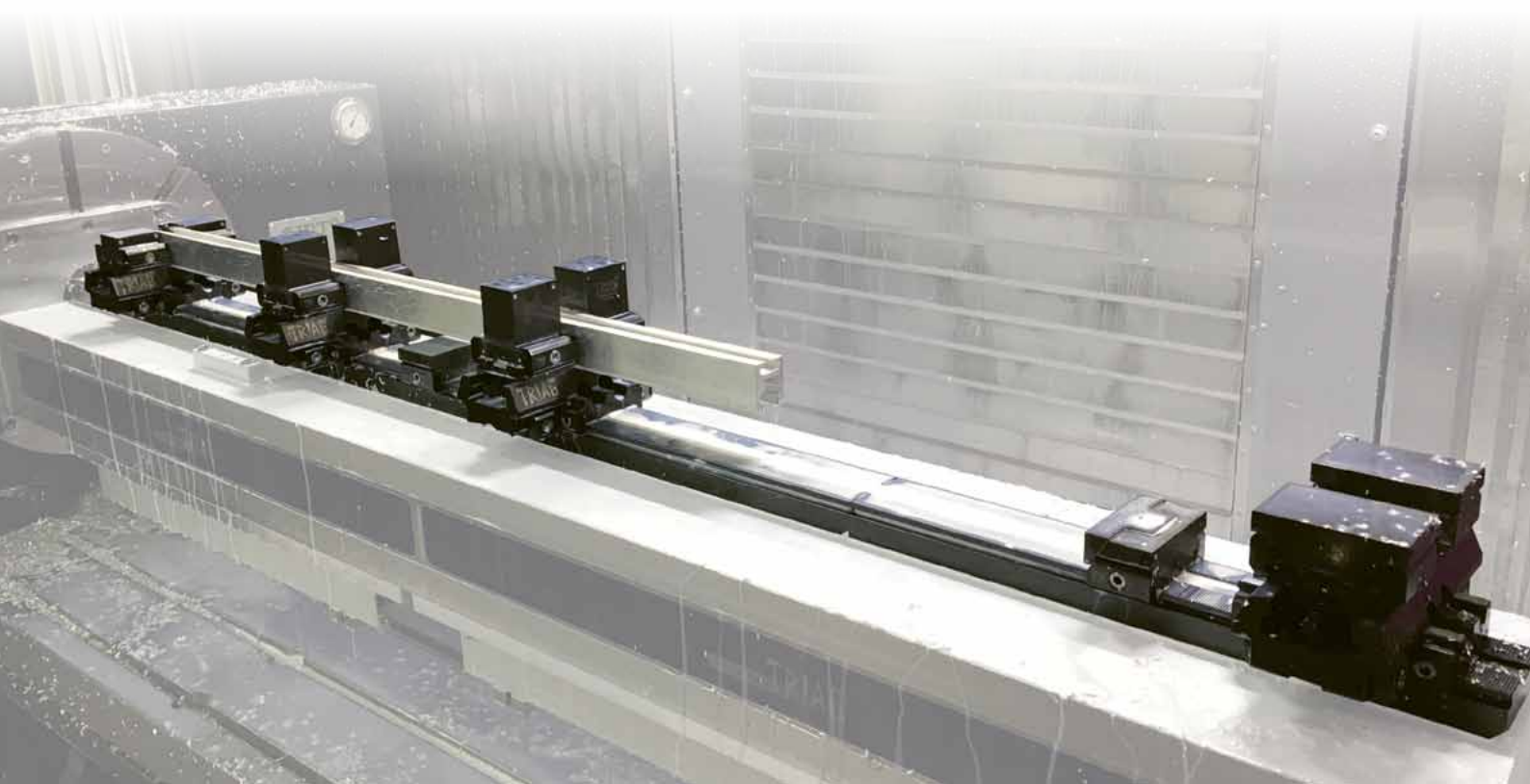
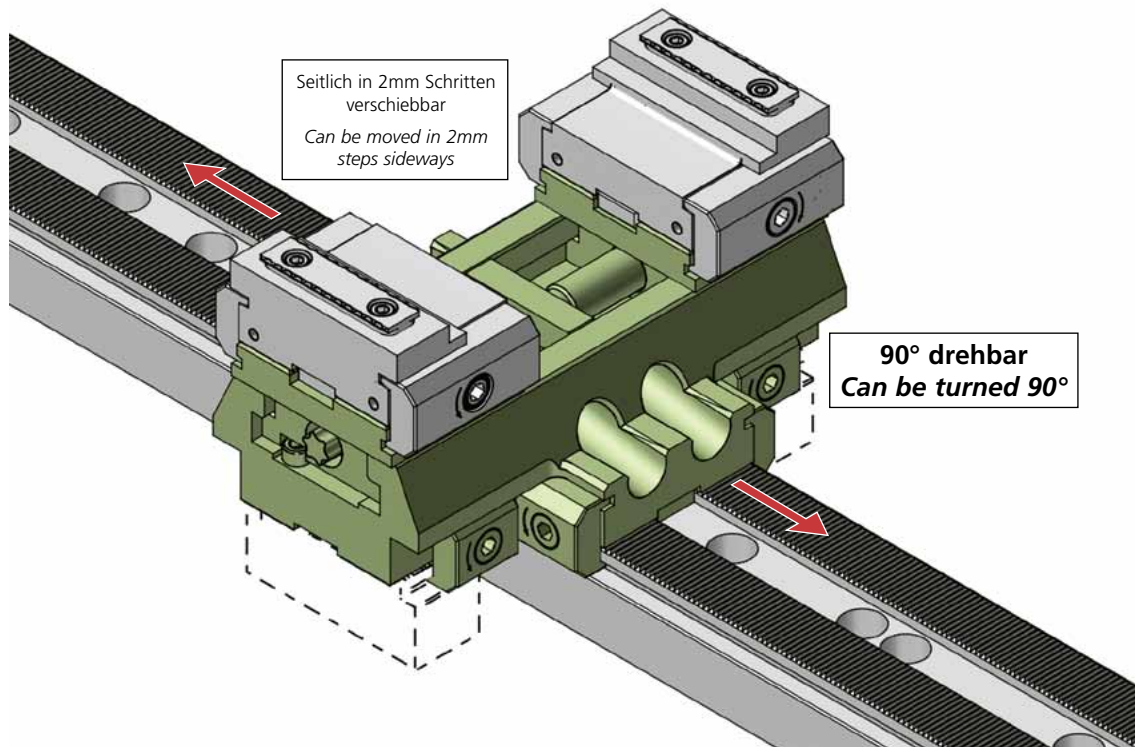

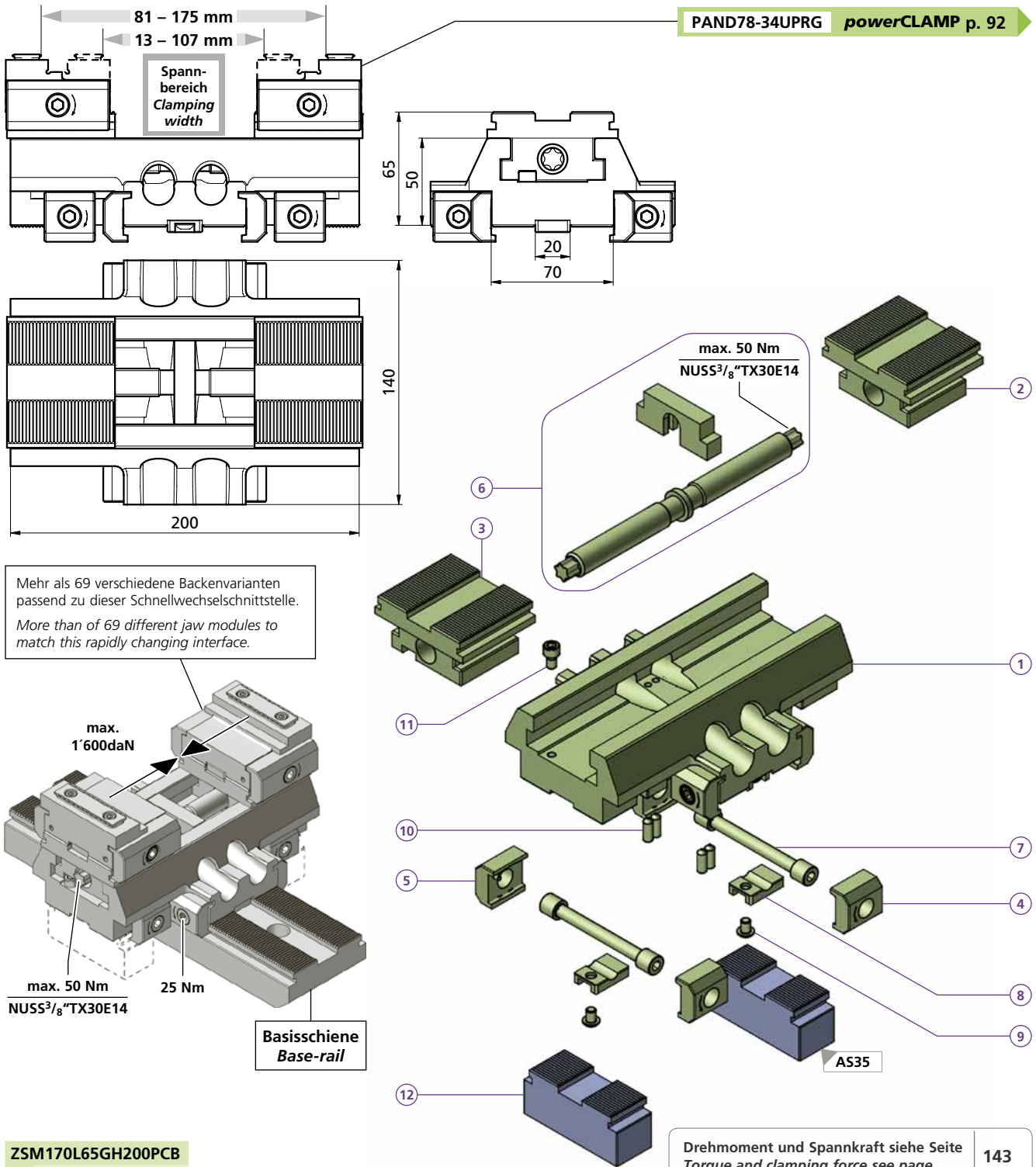

Mehr als 69 verschiedene Backenvarianten passend zu dieser Schnellwechselschnittstelle.  
More than of 69 different jaw modules to match this rapidly changing interface.

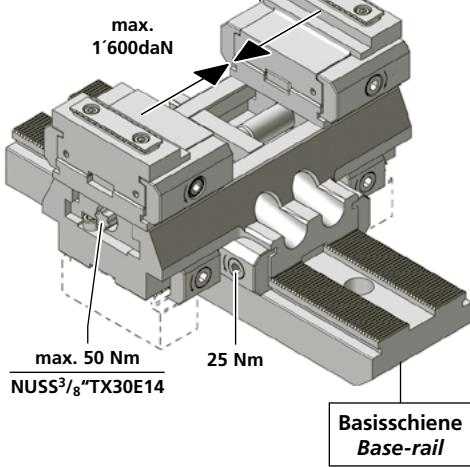

- ZSM170L65GH200PCB**
- ① 1x TB140566
  - ② 1x TB150092
  - ③ 1x TB150091
  - ④ 4x PCSP30L
  - ⑤ 4x PCSP30R
  - ⑥ 1x PCS16TR200SET
  - ⑦ 4x PCS14
  - ⑧ 4x PCGU2030
  - ⑨ 4x M6X8ISO7380
  - ⑩ 4x M6X16DIN914
  - ⑪ 1x M6X10ISO4762
  - ⑫ 2x \_\_\_\_\_
- kg ~8,6

Schienenhöhe / Rail height

AS35 (H = 35)	AS60 (H = 60)	AS80 (H = 80)

Drehmoment und Spannkraft siehe Seite 143  
Torque and clamping force see page 143

**WICHTIG!**  
Bitte separat bestellen  
**IMPORTANT!**  
Please order separately

**Seitliche Stützen**  
Bei Gebrauch dieses Zentrischspanners, werden je nach Höhe der Basisschiene auf dessen sie aufgesetzt wird, zwei seitliche Stützen AS35 / AS60 / AS80 unterlegt.

**Side support**  
When using this self centering vise, a side support AS35 / AS60 / AS80 is underlaid, depending on the height of the base rail on which it is placed.

Bestellbeispiel / Ordering example: 2 x ZSM170L65GH200PCB & 4 x AS35 & 1 x NUSS3/8\"/>

Separat bestellen / Separate order

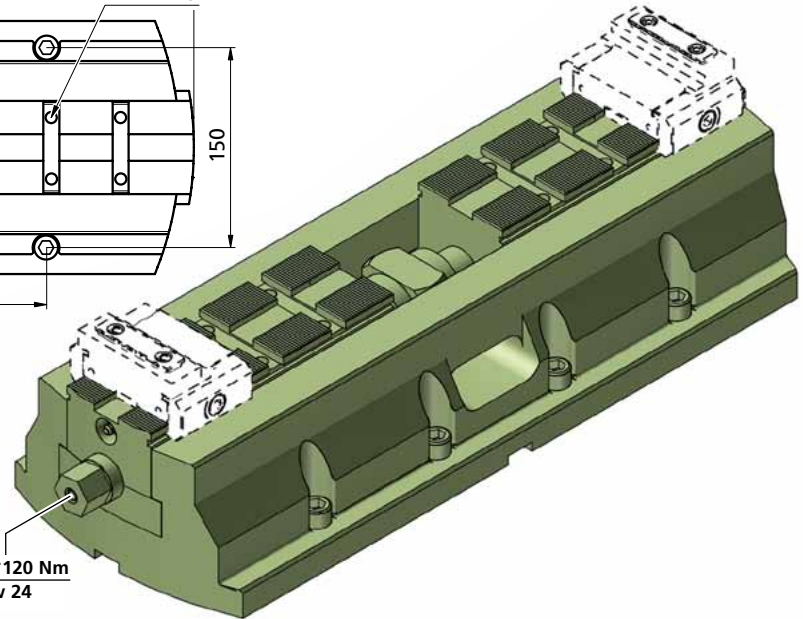
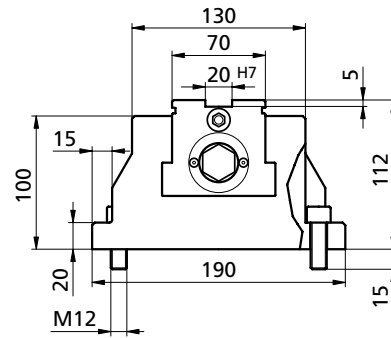
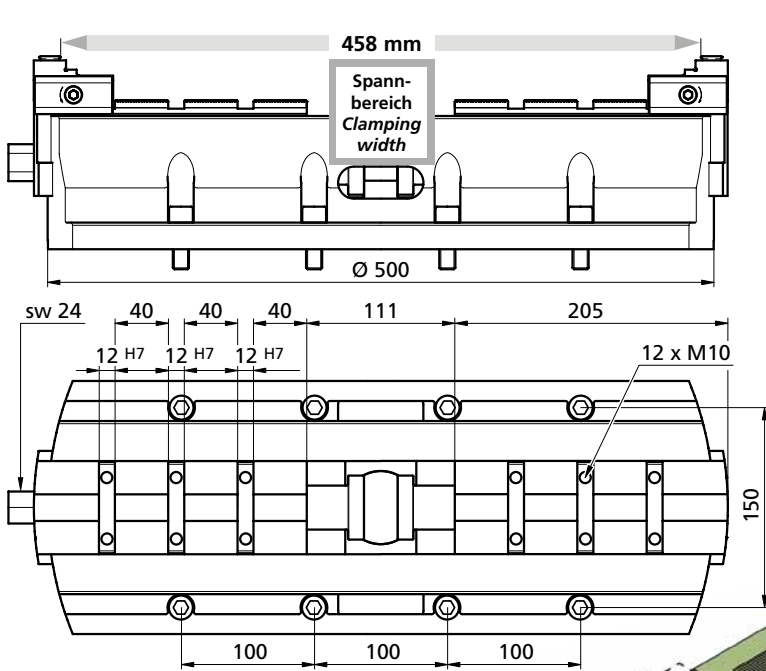

**ZSMB500L112** kg = ~59  
**Backenhub (pro Backe)**  
**Stroke of clamping (each jaw)**  
 55 mm

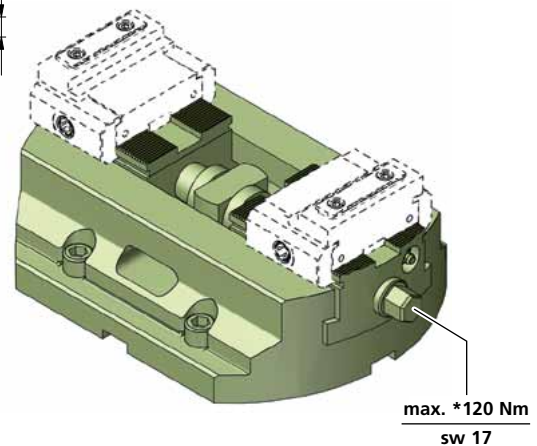
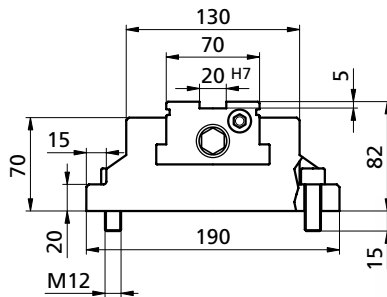
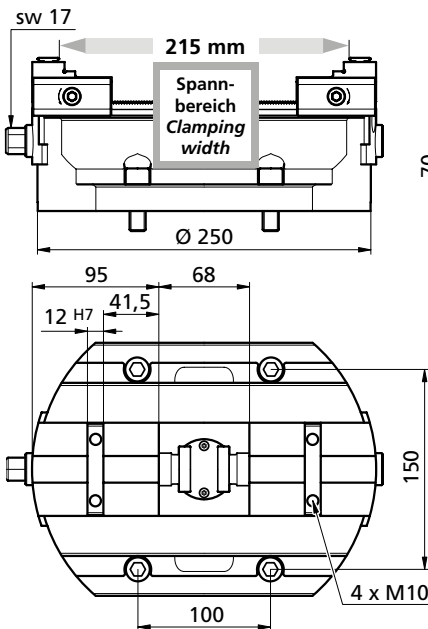

**ZSMB250L82** kg = ~19  
**Backenhub (pro Backe)**  
**Stroke of clamping (each jaw)**  
 35 mm

Drehmoment Torque		Spannkraft Workholding force			Gut zu Wissen Good to know
Nm	(lb-ft)	~daN	~(lb)	~t	
40	29,5	= 800	1798	0,8	Diese Spannkraften werden für den Dauerbetrieb empfohlen! These clamping forces are recommended for continuous operation!
60	44,26	= 1200	2697	1,2	
80	59	= 1600	3597	1,6	
100	73,75	= 2000	4496	2	
*120	88,5	= 2400	5395	2,4	Für kurzfristige Anwendung For short-term application

**!** Für längerfristige Anwendung ab 140 – 250 Nm müssen **geschraubte Backen** eingesetzt werden!  
 For longer-term use from 140 – 250 Nm the **screwed jaws** must be used!

Bestellbeispiel / Ordering example : ZSMB500L112





# PAND94-49PRF-A1-P

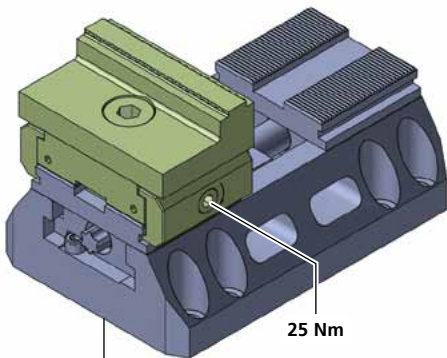
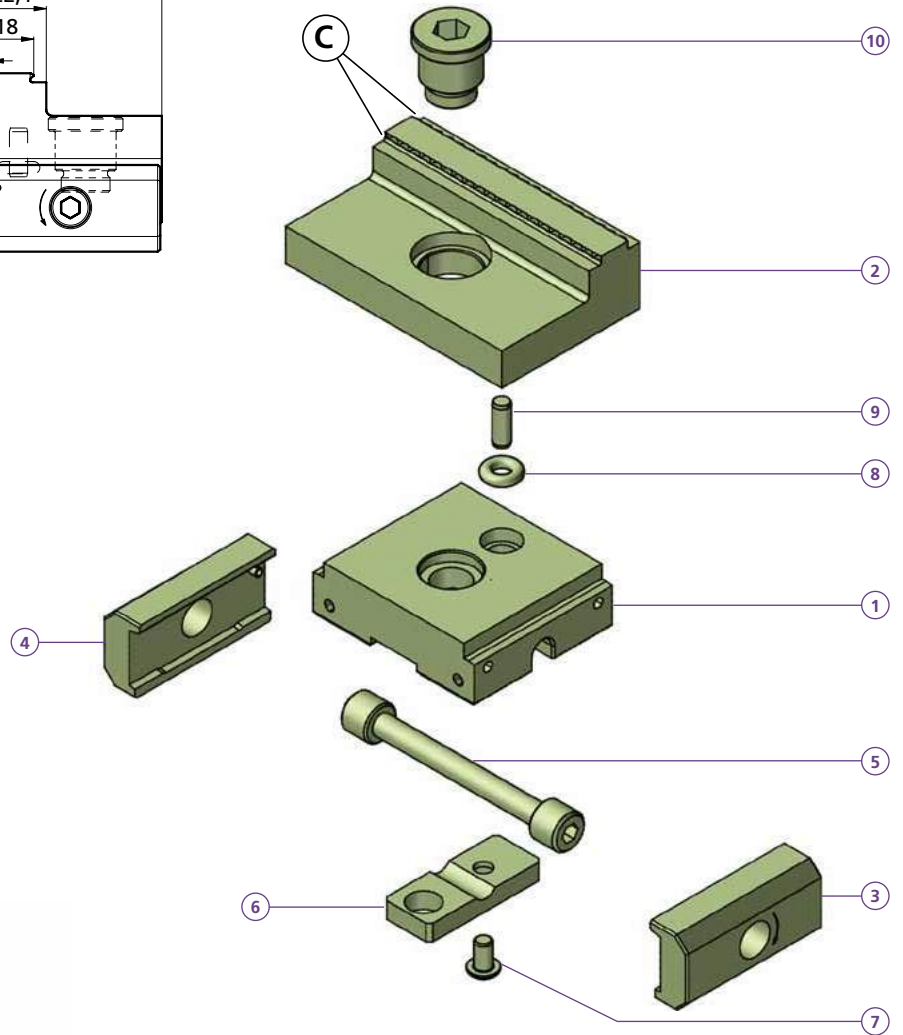
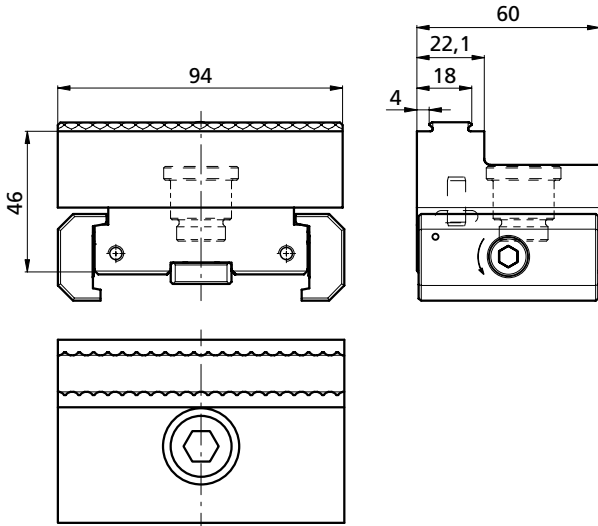

p. 144 ZSM180L50

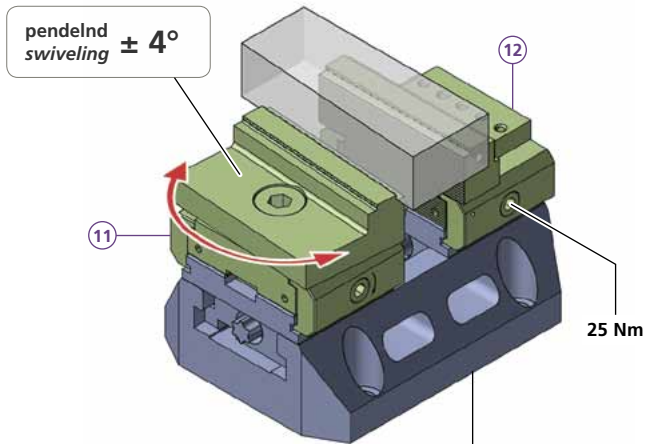

p. 144 ZSM140L50

PAND94-49PRF-A1-P	
1	1x TF180103
2	1x TF180102
3	1x PCSP60R
4	1x PCSP60L
5	1x PCS14
6	1x PCGU2049
7	1x M6X10ISO7380
8	1x OR6x40-RingNBR70
9	1x 6m6x16DIN6325
10	1x TK130236
kg	~1,8

PAND94-49PRF-A1-P-NS18	
11	1x PAND94-49PRF-A1-P
12	1x PAND94-49PRG-A1
kg	~3,4

Bestellbeispiel / Ordering example: PAND94-49PRF-A1-P

Separat bestellen / Separate order



Drehmoment Torque		Spannkraft Workholding force			Gut zu Wissen Good to know
Nm	(lb-ft)	~daN	~(lb)	~t	
10	7,4	= 200	440	0,2	Diese Spannkraften werden für den Dauerbetrieb empfohlen! <i>These clamping forces are recommended for continuous operation!</i>
20	14,8	= 500	1'102	0,5	
30	22,2	= 1'000	2'204	1,0	
40	29,6	= 1'300	2'866	1,3	
50	37,0	= 1'600	3'527	1,6	
60	44,4	= 1'800	3'968	1,8	Für kurzfristige Anwendung <i>For short-term application</i>
70	51,8	= 2'100	4'629	2,1	

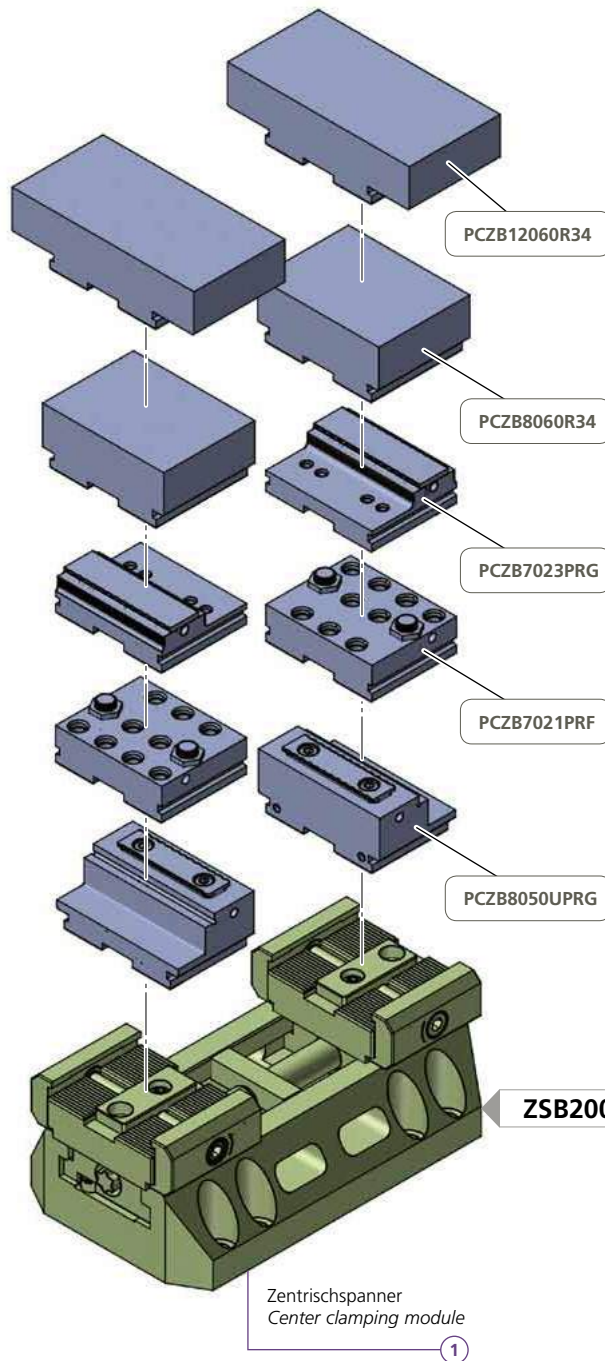
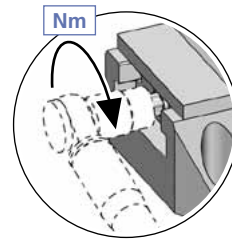

Mehr als **8** verschiedene Backenvarianten passend zu dieser Schnellwechelschnittstelle.  
*More than 8 different jaw modules to match this rapidly changing interface.*

	kg
① ZSB200L50	~8,4
ZSB180L50	~7,9
ZSB160L50	~7,4
ZSB140L50	~6,7
2x	

p. 152

Bestellbeispiel / Ordering example: 1 x ZSM200L50 & 2 x PCZB8050UPRG

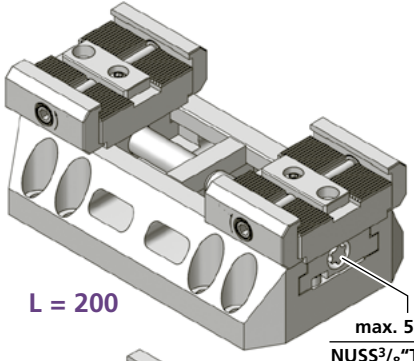

L = 200

max. 50 Nm  
NUS3/8"TX30E14

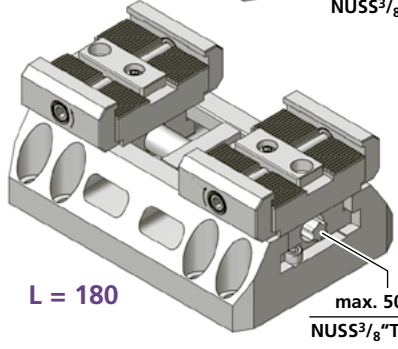

L = 180

max. 50 Nm  
NUS3/8"TX30E14

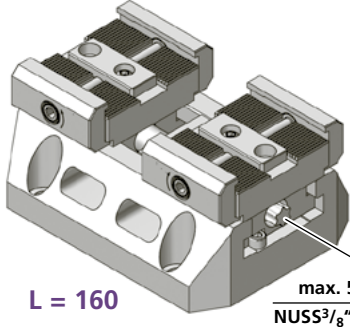

L = 160

max. 50 Nm  
NUS3/8"TX30E14

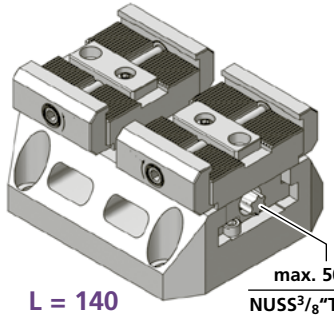

L = 140

max. 50 Nm  
NUS3/8"TX30E14

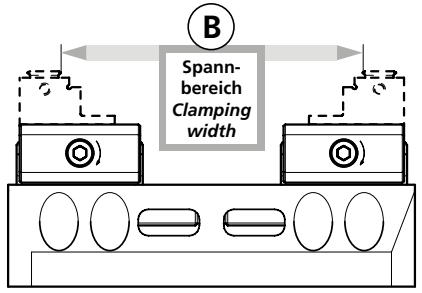
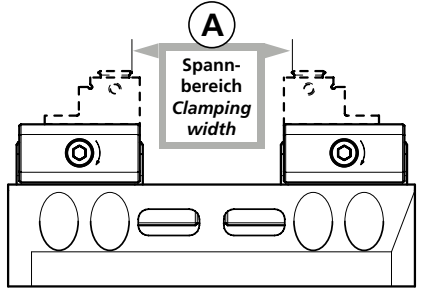
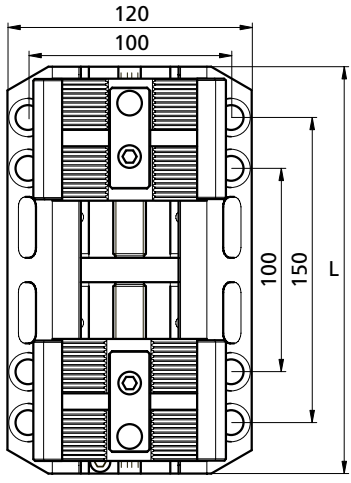
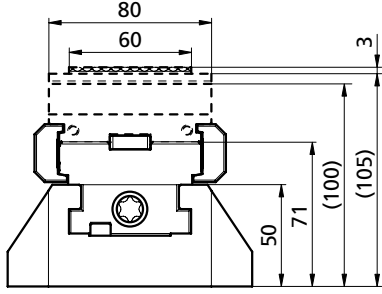

PCZB8050UPRG p. 152

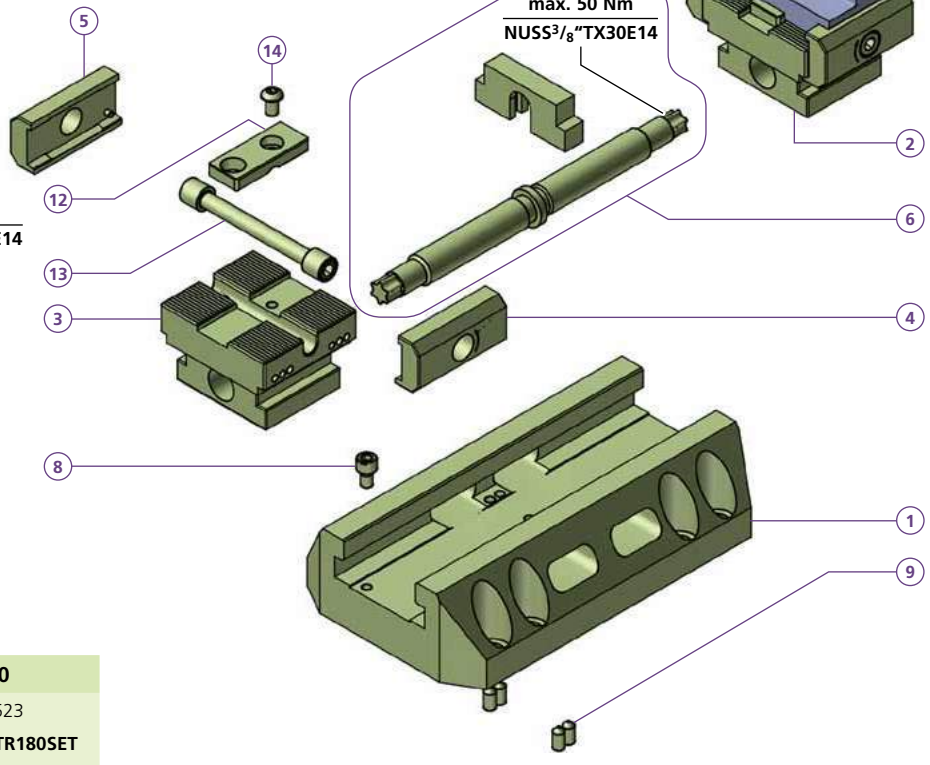

ZSB200L50	
1	1x TK150025
2	1x ZB150791
3	1x ZB150792
4	2x PCSP60RG
5	2x PCSP60LG
6	1x PCS16TR200SET
8	1x M6X10ISO4762
9	4x M6X16DIN914
12	2x PCGU2049
13	2x PCS14
14	2x M6X8ISO7380
L	= 200
A	10 – 126 mm
B	58 – 174 mm
kg	~8,4

ZSB180L50	
1	1x TK150523
6	1x PCS16TR180SET
L	= 180
A	10 – 104 mm
B	58 – 154 mm
kg	~7,9

ZSB160L50	
1	1x TK150522
6	1x PCS16TR160SET
L	= 160
A	10 – 86 mm
B	58 – 134 mm
kg	~7,4

ZSB140L50	
1	1x TK150521
6	1x PCS16TR140SET
L	= 140
A	10 – 65 mm
B	58 – 113 mm
kg	~6,7

Drehmoment und Spannkraft siehe Seite 149  
Torque and clamping force see page 149

**WICHTIG!**  
Bitte separat bestellen

**IMPORTANT!**  
Please order separately

NUS3/8"TX30E14

Bestellbeispiel / Ordering example: 3 x ZSB200L50 & 6 x PCZB8050UPRG & 1 x NUS3/8"TX30E14



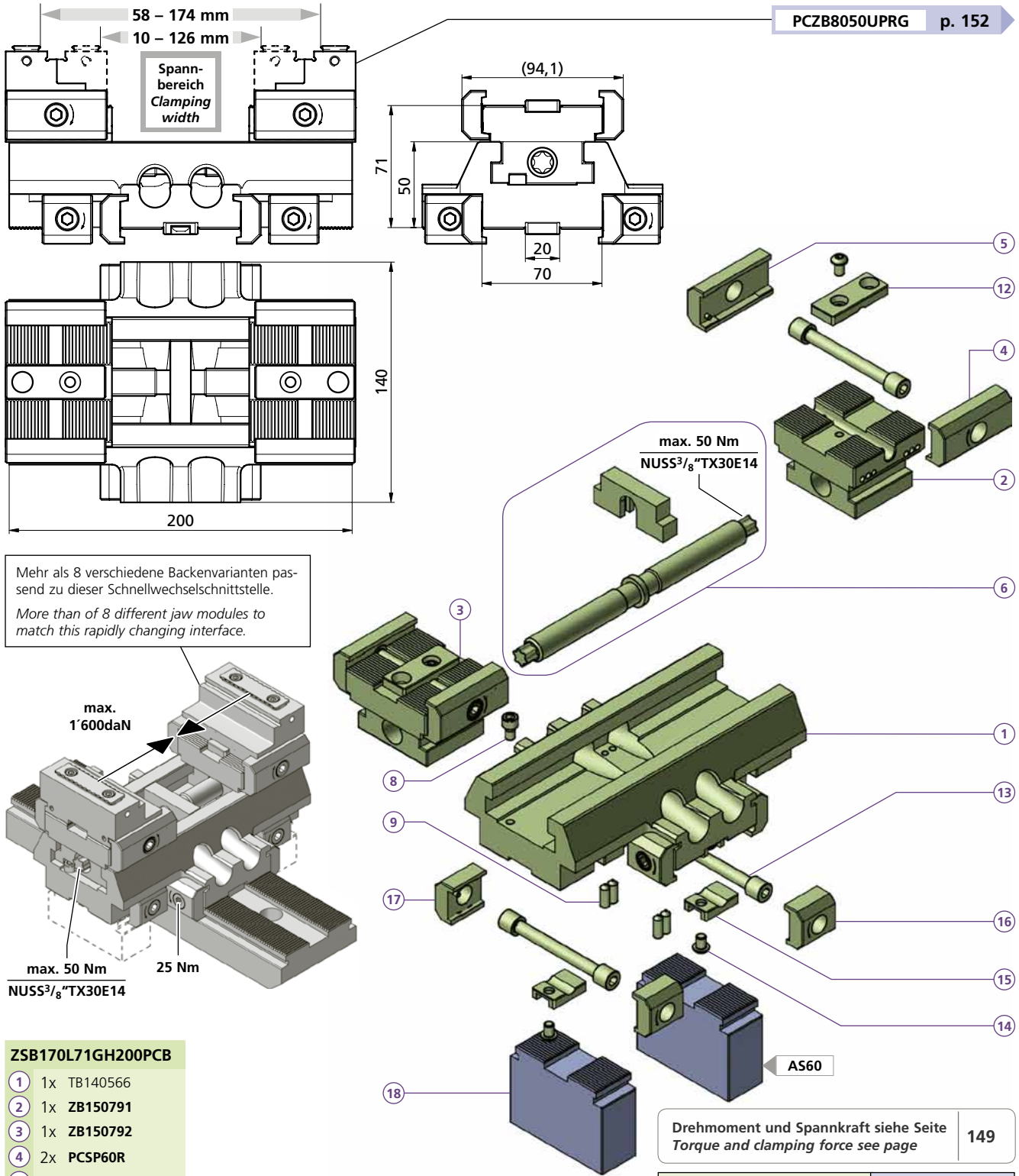

Mehr als 8 verschiedene Backenvarianten passend zu dieser Schnellwechselschnittstelle.  
More than of 8 different jaw modules to match this rapidly changing interface.

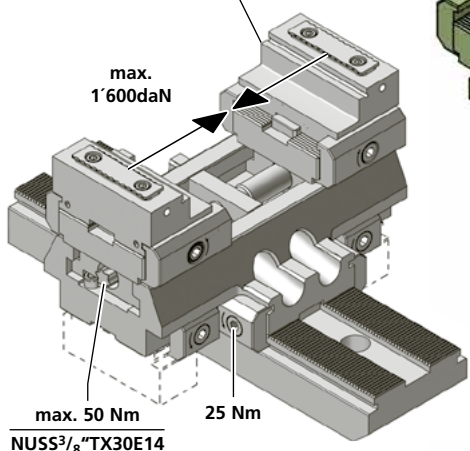

- ZSB170L71GH200PCB**
- 1 1x TB140566
  - 2 1x ZB150791
  - 3 1x ZB150792
  - 4 2x PCSP60R
  - 5 2x PCSP60L
  - 6 1x PCS16TR200SET
  - 8 1x M6X10ISO4762
  - 9 4x M6X16DIN914
  - 12 2x PCGU2049
  - 13 4x PCS14
  - 14 4x M6X8ISO7380
  - 15 2x PCGU2030
  - 16 4x PCSP30L
  - 17 4x PCSP30R
  - 18 2x \_\_\_\_\_
- kg ~9,2

**Schienenhöhe / Rail height**

AS35 (H = 35)	AS60 (H = 60)	AS80 (H = 80)

Drehmoment und Spannkraft siehe Seite 149  
Torque and clamping force see page 149

**WICHTIG!**  
Bitte separat bestellen  
**IMPORTANT!**  
Please order separately

**Seitliche Stützen**  
Bei Gebrauch dieses Zentrischspanners, werden je nach Höhe der Basisschiene auf dessen sie aufgesetzt sind, zwei seitliche Stützen AS35 / AS60 / AS80 unterlegt.

**Side support**  
When using this self centering vise, a side support AS35 / AS60 / AS80 is underlaid, depending on the height of the base rail on which it is placed.

Bestellbeispiel / Ordering example: 1 x ZSB170L71GH200PCB & 2 x PCZB8050UPRG & 1 x NUSS3/8\"/>

Separat bestellen / Separate order

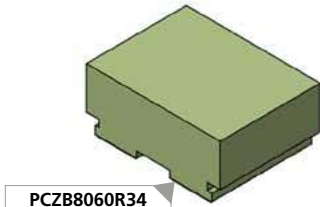
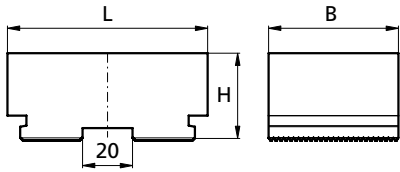

PCZB8060R34

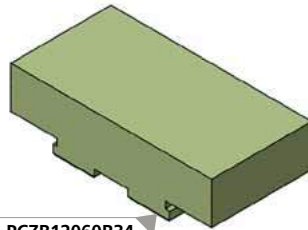

PCZB12060R34

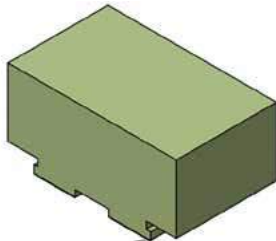

PCZB10060R50ST

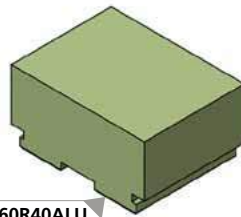

PCZB8060R40ALU

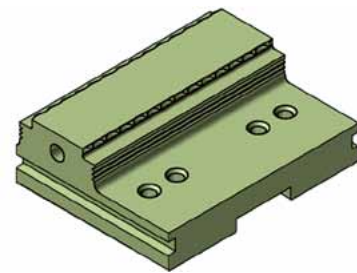
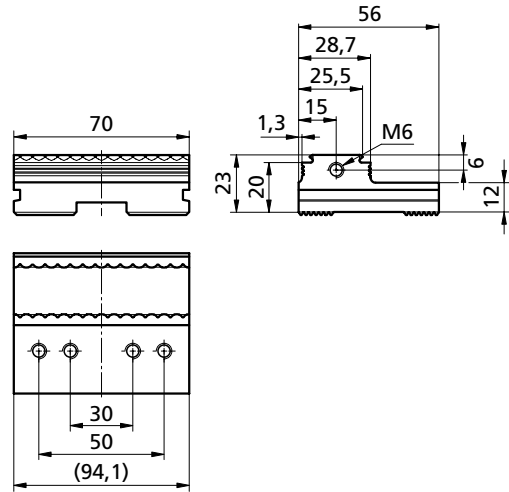

		L	B	H	kg
PCZB8060R34	(Stahl/Steel)	80	60	34	~1,2
PCZB12060R34	(Stahl/Steel)	120	60	34	~1,7
PCZB10060R50ST	(Stahl/Steel)	101	60	50	~2,2
PCZB8060R40ALU	ALU	80	60	40	~0,52
PCZB10060R50	ALU	101	60	50	~0,76

PCZB7023PRG kg ~0,54

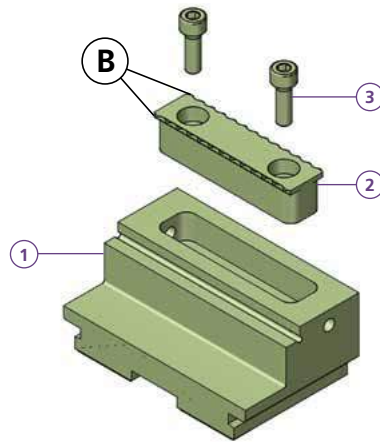

PCZB8050UPRG

- ① 1x TB161200
  - ② 1x MAND58-14PRG
  - ③ 1x M5X16ISO4762
- kg ~0,75

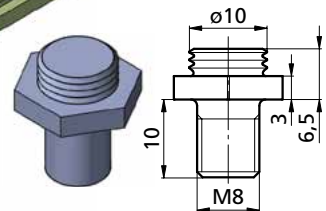
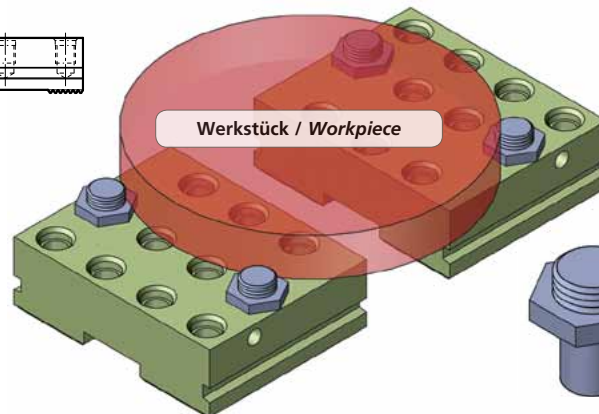
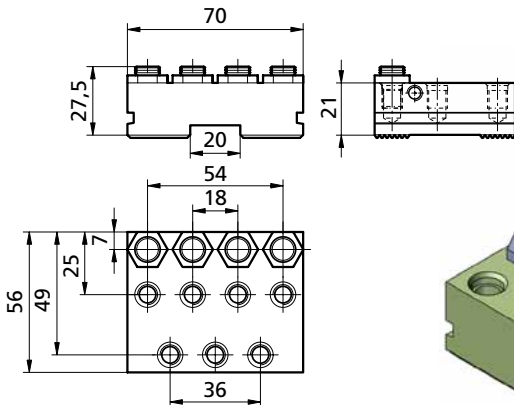
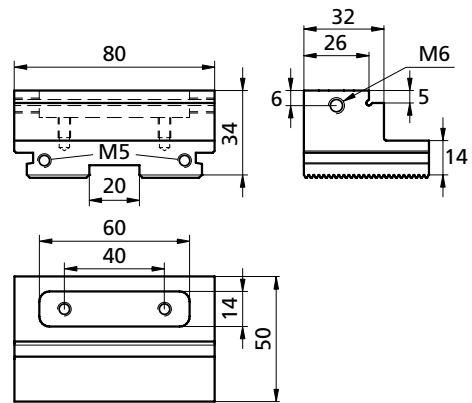

PCZB7021PRF kg ~0,6

PRG1003M8

Bestellbeispiel / Ordering example: 2 x PCZB7021PRF & 4 x PRG1003M8



SPUTNIK III

**Sputnik III**

Spannbereich bis 180 mm, Spannkraft bei 70 Nm, 2,1 t/2100 daN. Hier kommen die «Grossen» unserer Zentrischspanner zum Einsatz. Speziell ist der Aufbau auf einer Stahl-Mineralgusspyramide um beste Verhältnisse bezüglich Vibrationsdämpfung zu bieten. Die Zentrischspanner dazu gibt es in vier Gehäuselängen (140, 160, 180 und 200 mm) und bis zu 60 Backenvarianten.

**Sputnik III**

Spans of up to 180 mm, clamping force at 70 Nm, 2.1 t/2100 daN. Here the «big ones» of our self-centering vices go into action. And there is the special setup of a steel mineral casting pyramid to provide the best conditions for vibration dampening. The self-centering vice for this is available with four housing lengths (140, 160, 180 and 200 mm) and up to 60 jaw versions.

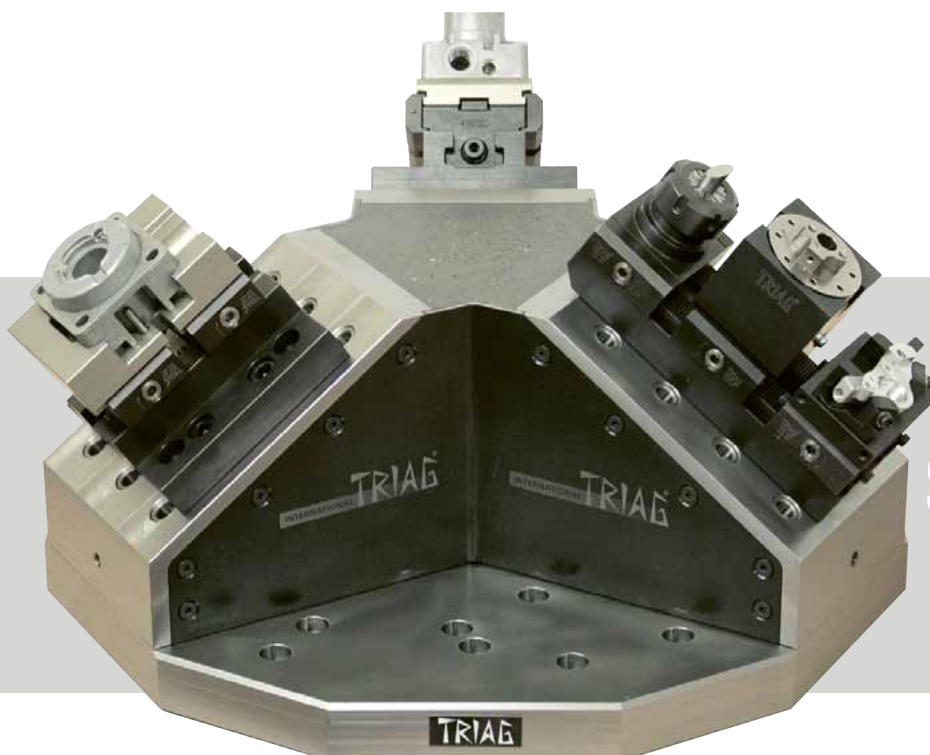

SPUTNIK III





SPUTNIK III

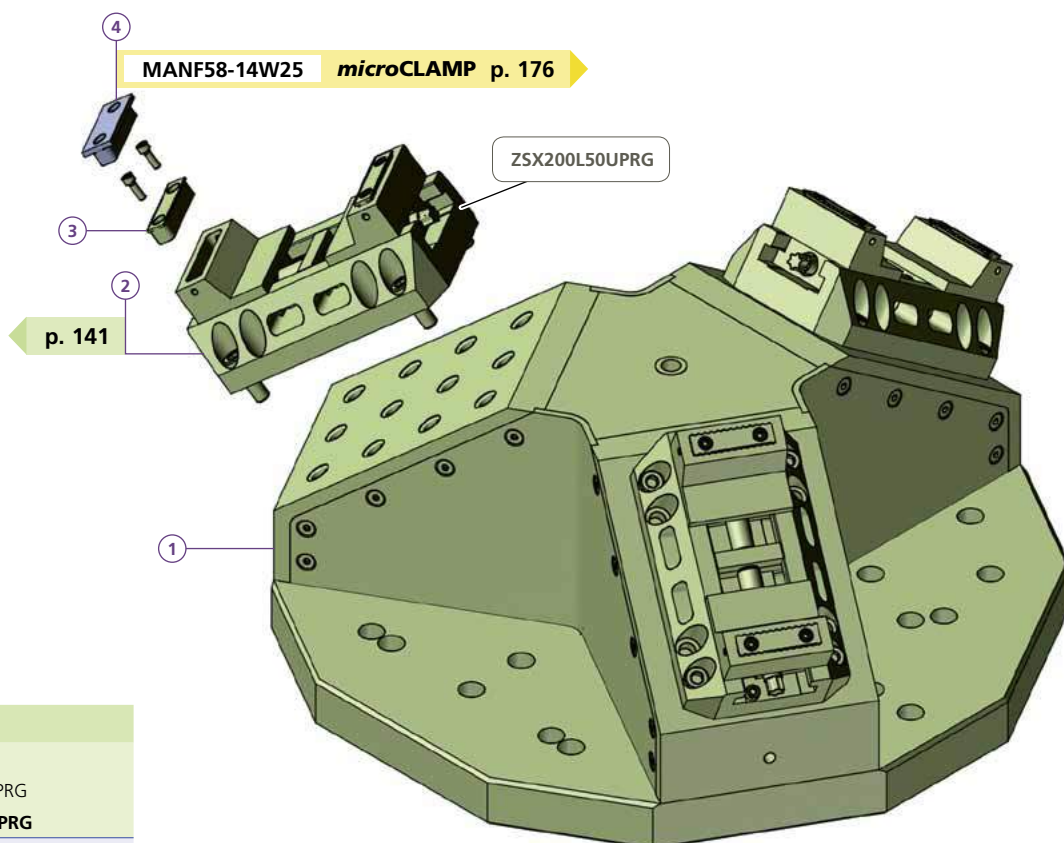
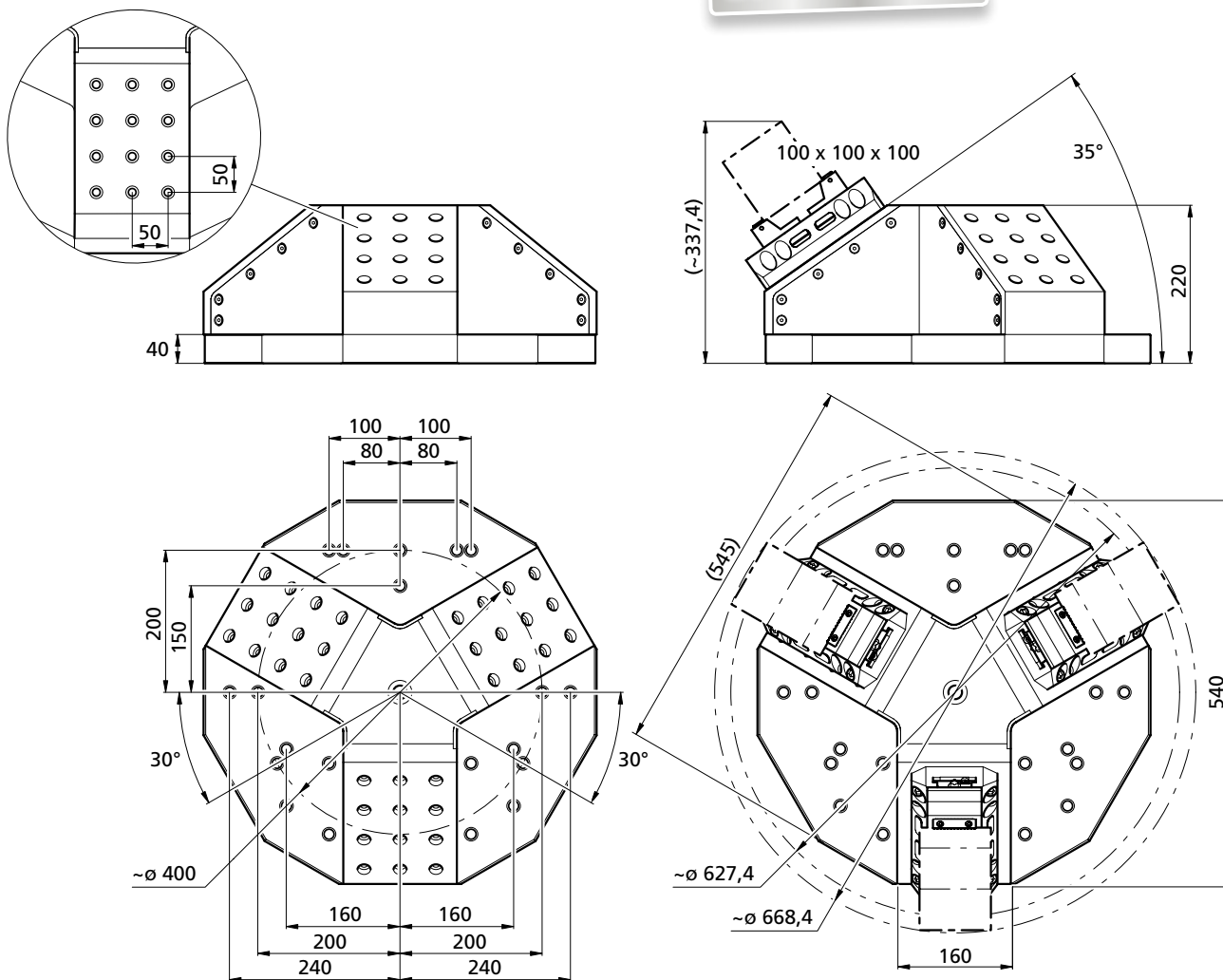

<b>5AXZSX35-3</b>	
①	1x ZK151003
②	3x ZSX200L50UPRG
③	6x MAND58-14PRG
④	6x MANF58-14W25
kg	~185

Bestellbeispiel / Ordering example: 1 x 5AXZSX35-3 & 3 x ZSX200L50UPRG & 6 x MANF58-14W25

Separat bestellen / Separate order

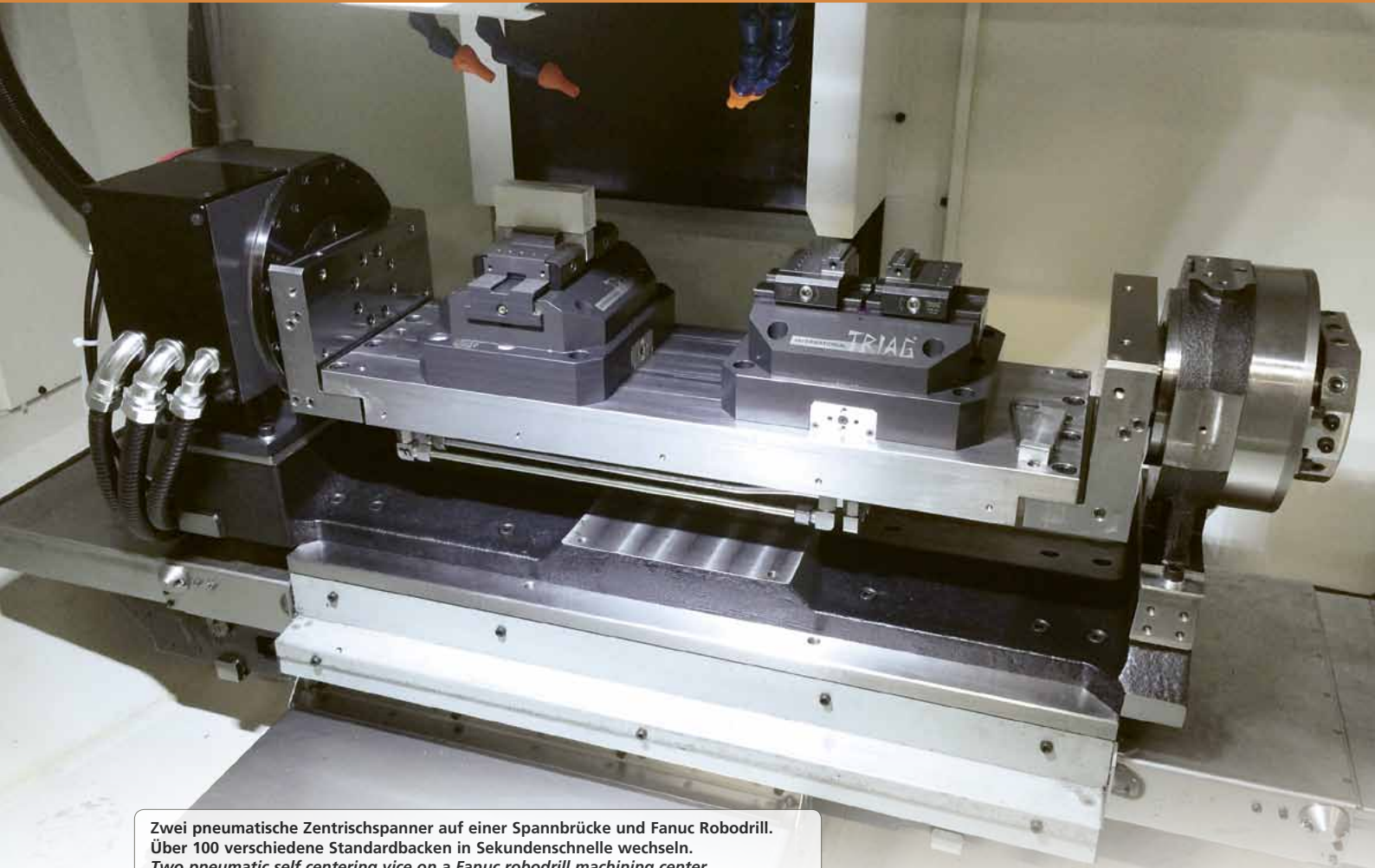

Zwei pneumatische Zentrischspanner auf einer Spannbrücke und Fanuc Robodrill.  
Über 100 verschiedene Standardbacken in Sekundenschnelle wechseln.  
*Two pneumatic self centering vise on a Fanuc robodrill machining center.  
From more than 100 different standard jaw modules can be changed in a view second.*

ZSP40L38-2



ZSP200L55

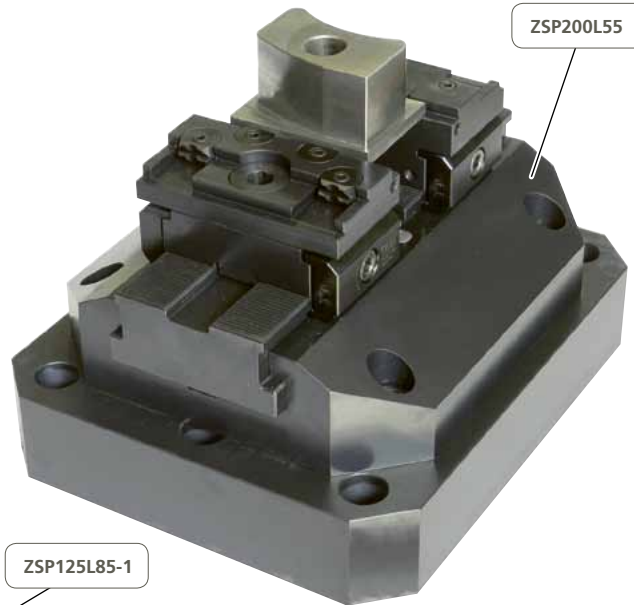

ZSP125L85-1



# ZSP Micro Pneumatischer Zentrischspanner

## Pneumatic self centering vise

### SET18ZSP40L38-2 ZSP40L38-2



triCENTRO

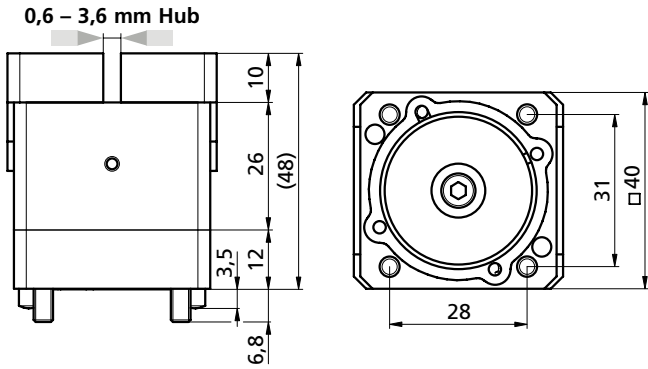

**Zum Erstellen Ihrer individuellen Formbacke:**  
Schnittzeichnung zum Ermitteln der maximalen Bearbeitungsprofiltiefe

**If a dedicated jaw is being machined:**  
Sectional drawing to determine the maximum machining depth

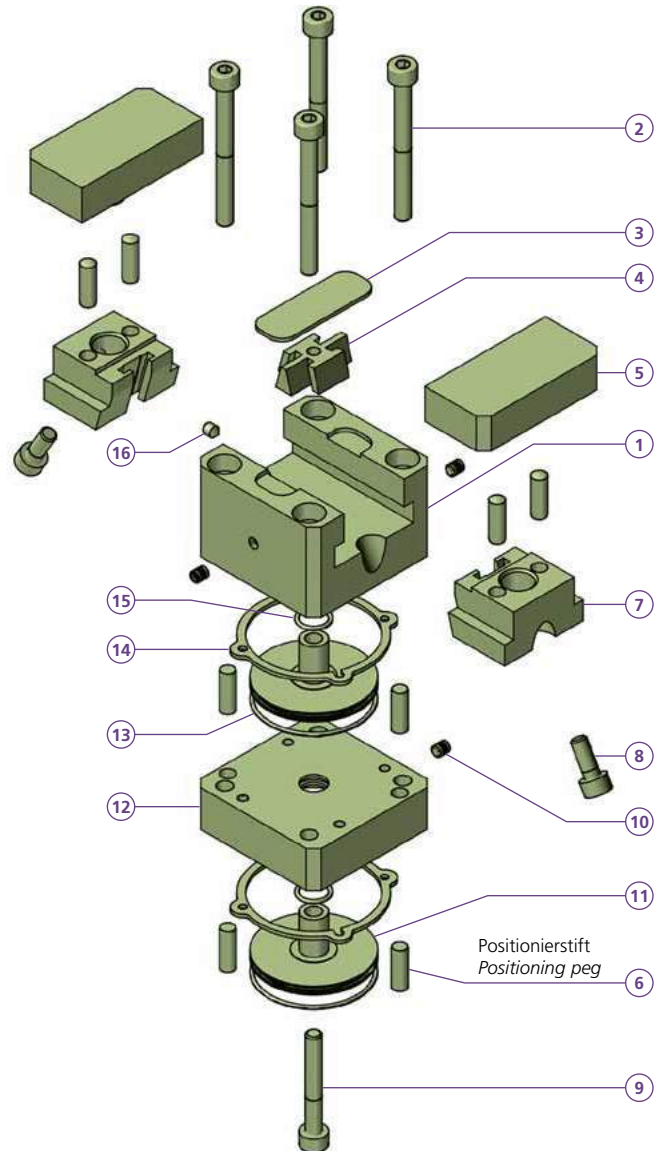

**Spannkraft / Workholding force**  
120 daN (max. 6 Bar)

**4 Anschlüsse / Connections**

- Spannen / Clamping
- Lösen / Loosen
- Überwachen / Supervise
- Sperrluft / Sealing air

- SET18ZSP40L38-2**
- 1 1x TF180166
  - 2 4x TN100865
  - 3 1x TF180169
  - 4 1x TF180168
  - 5 2x B222
  - 6 8x TN100428
  - 7 2x TF180167
  - 8 2x TN100321
  - 9 1x TB180316
  - 10 3x TN100824
  - 11 2x TF180170
  - 12 1x TF180171
  - 13 2x TN100819
  - 14 2x TB180306
  - 15 2x TN100818
  - 16 1x TN10091
- kg ~0,52

Luftvolumen / Air volume	
Spannen / Clamping	Lösen / Loosen
8,2cm <sup>3</sup>	8,4cm <sup>3</sup>

Bedienungsanleitung zu diesem pneumatischen Zentrischspanner  
Operating instructions for this pneumatic self centering vise

max. 120daN

weich soft 1.7225

**ZSP40L38-2**

5	2x B222
kg	~5,2

Bestellbeispiel / Ordering example: SET18ZSP40L38-2

Separat bestellen / Separate order



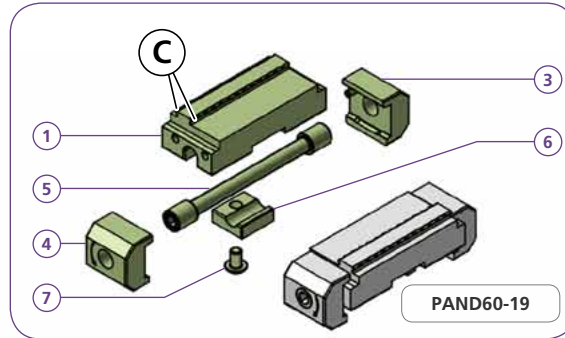
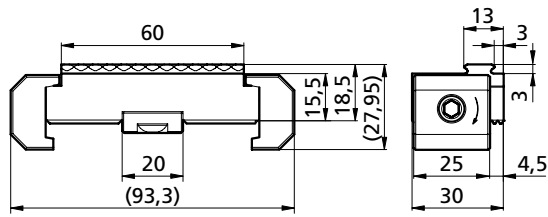
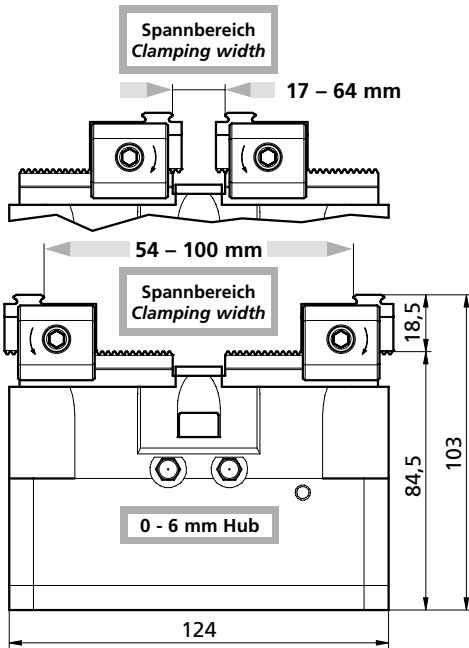

#### ZSP125L85-1

- 1 1x TB180474
  - 2 2x TB180476
  - 3 2x **M8X16ISO4762**
  - 4 2x M3X6DIN7991
  - 5 1x TB171140
  - 6 1x TB171141
  - 7 1x TB180477
  - 8 2x TN100014
  - 9 2x TB170530
  - 10 2x TN100021
  - 11 3x TN100009
  - 12 1x TK160467
  - 13 1x TN100012
  - 14 1x TK160075
  - 15 1x **M6X35ISO4762**
  - 16 1x TN100020
  - 17 1x TB180475
  - 18 2x TN100015
  - 19 4x TN100013
  - 20 1x TN100027
  - 21 1x TB180268
  - 22 4x PCPF16L6
  - 23 1x M5X6DIN913
  - 24 1x TB180478
- kg ~7,4

#### PAND60-19

- 1 1x TB171149
  - 3 1x PCSP25L
  - 4 1x PCSP25R
  - 5 1x PCS10
  - 6 1x PCGU2019
  - 7 1x **M5X8ISO7380**
- kg ~0,4

Luftvolumen / Air volume	
Spannen / Clamping	Lösen / Loosen
80,1 cm <sup>3</sup>	80,8 cm <sup>3</sup>



Bedienungsanleitung zu diesem pneumatischen Zentrischspanner  
Operating instructions for this pneumatic self centering vise

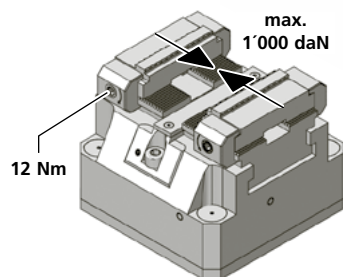

SET18ZSP125L85-1	
1x	ZSP125L85-1
2x	PAND60-19
kg	~8,2

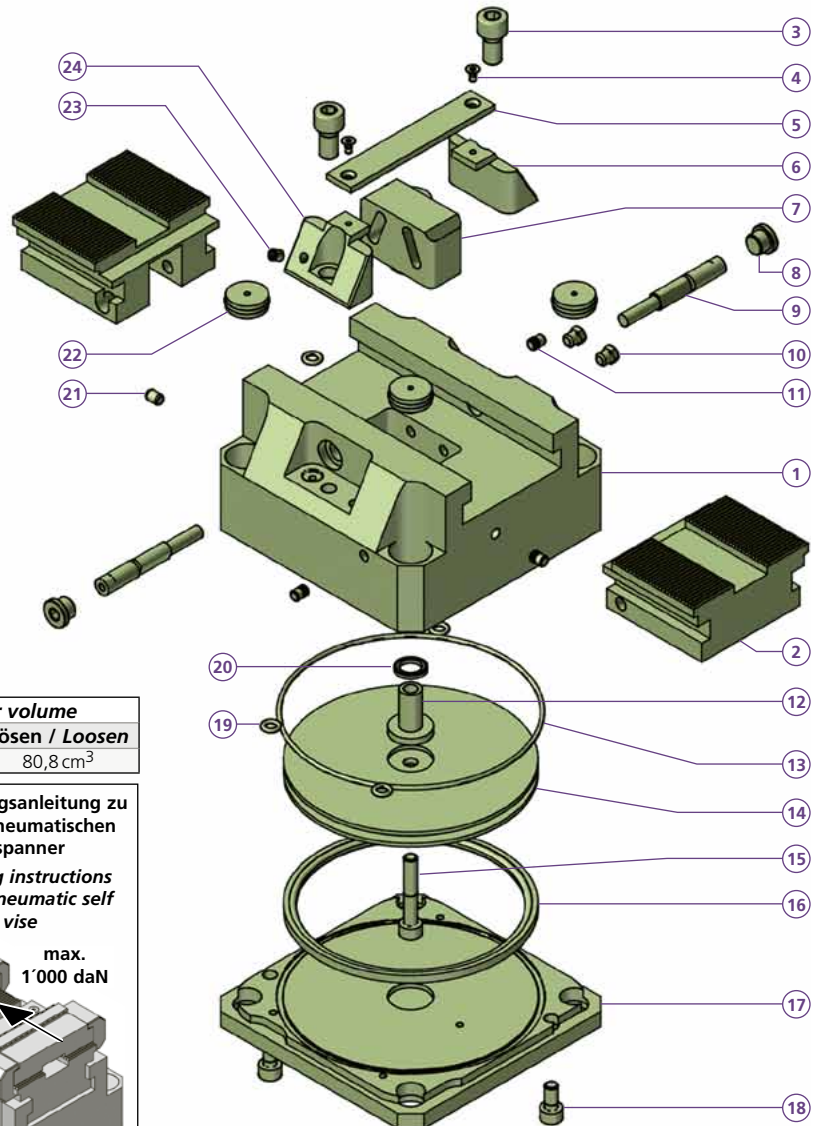

	Druck Pressure		Spannkraft Clamping force		
	Bar	~daN	~(lb)	~t	
Einfacher Kolben Single piston	8	= 600	1'320	0,6	
	10	= 800	1'760	0,8	
	12	= 1'000	2'650	1,0	

Bestellbeispiel / Ordering example: SET18ZSP125L85-1

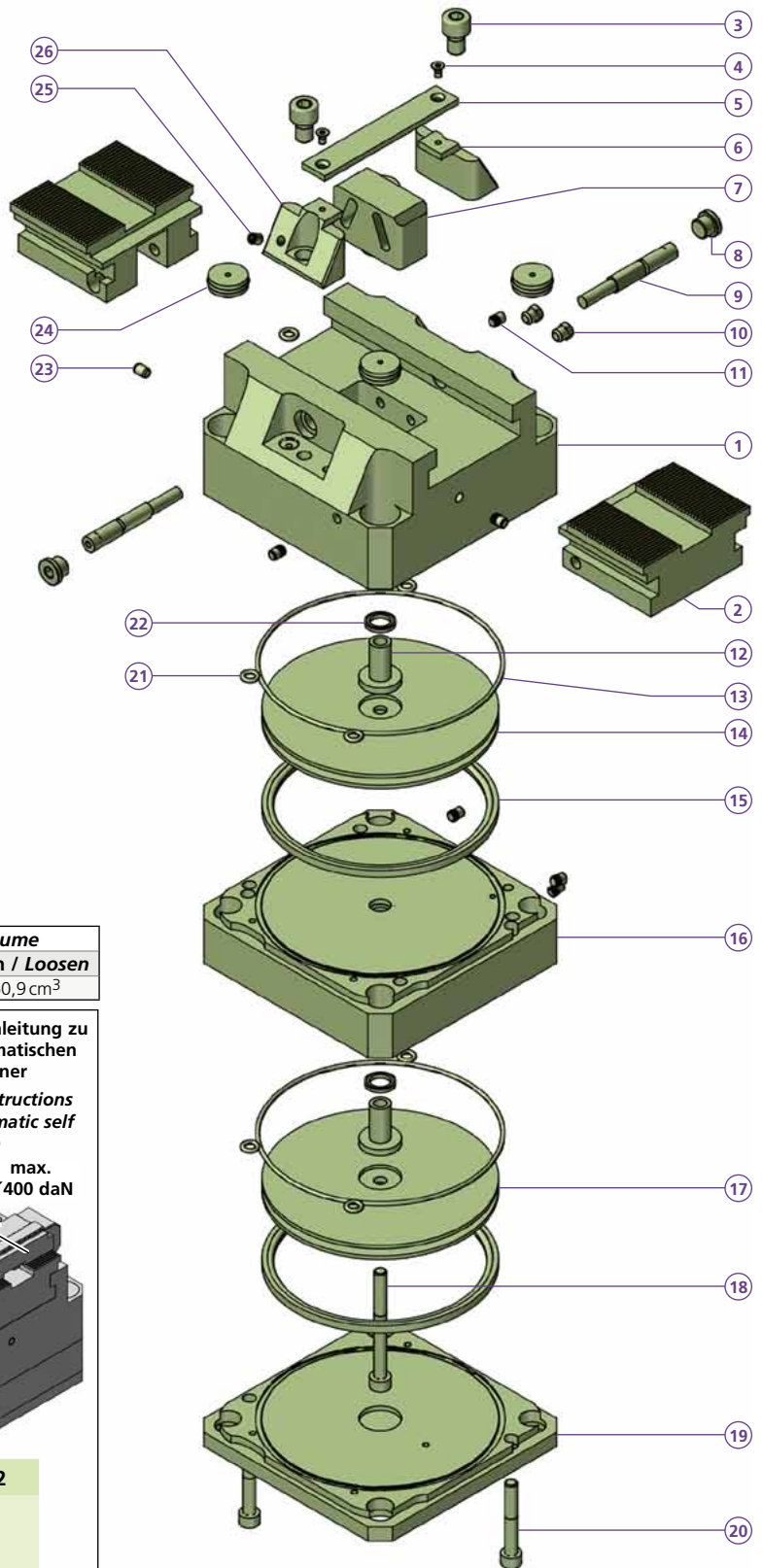
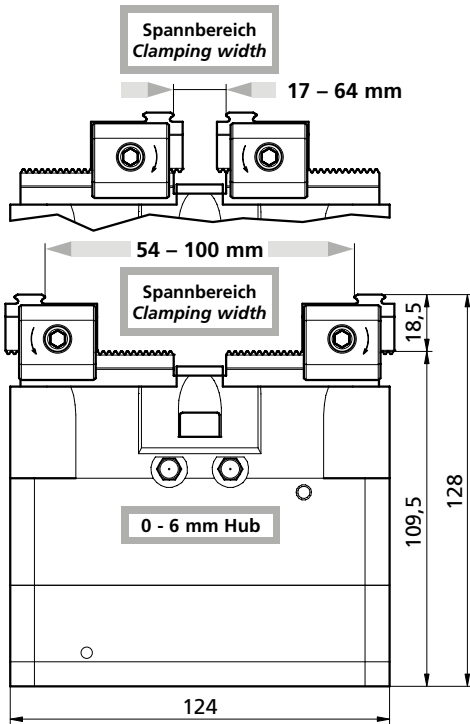

#### ZSP125L110-2

- 1 1x TB180474
- 2 2x TB180476
- 3 2x **M8X16ISO4762**
- 4 2x M3X6DIN7991
- 5 1x TB171140
- 6 1x TB171141
- 7 1x TB180477
- 8 2x TN100014
- 9 2x TB170530
- 10 2x TN100021
- 11 6x TN100009
- 12 2x TK160467
- 13 2x TN100012
- 14 1x TB170147
- 15 2x TN100020
- 16 1x TB180480
- 17 1x TK160075
- 18 1x **M6X60ISO4762**
- 19 1x TB180475
- 20 2x **M6X40ISO4762**
- 21 7x TN100013
- 22 2x TN100027
- 23 1x TB180268
- 24 4x PCPF16L6
- 25 1x M5X16DIN913
- 26 1x TB180478
- kg ~9,4

Luftvolumen / Air volume	
Spannen / Clamping	Lösen / Loosen
160,2 cm <sup>3</sup>	160,9 cm <sup>3</sup>



Bedienungsanleitung zu diesem pneumatischen Zentrischspanner  
Operating instructions for this pneumatic self centering vise

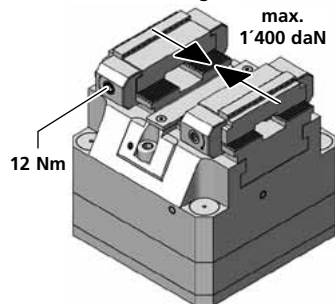

#### SET18ZSP125L110-2

- 1x ZSP125L110-2
- 2x PAND60-19
- kg ~11,3

#### PAND60-19

- 1 1x TB171149
- 3 1x PCSP25L
- 4 1x PCSP25R
- 5 1x PCS10
- 6 1x PCGU2019
- 7 1x **M5X8ISO7380**
- kg ~0,4

Masszeichnung & Isometrische Darstellung:

Siehe Seite | See page **p. 159**

Dimensional drawing & Isometric representation:

	Druck Pressure		Spannkraft Clamping force		
	Bar		~daN	~(lb)	~t
Doppelkolben Double piston	8	=	1'000	2'200	1,0
	10	=	1'400	3'090	1,4

Bestellbeispiel / Ordering example : SET18ZSP125L110-2

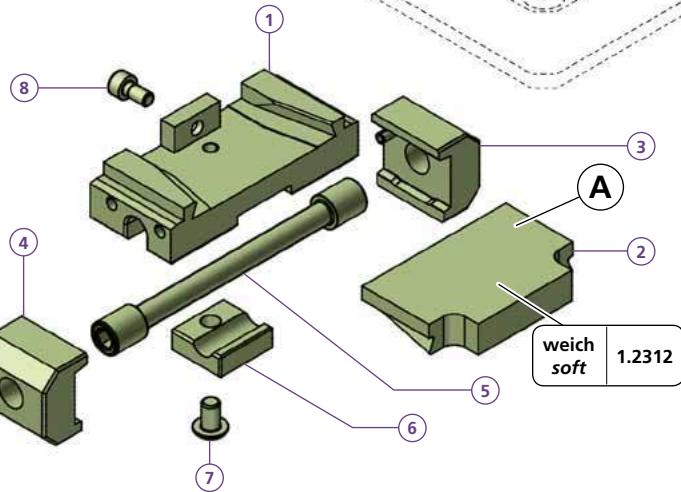
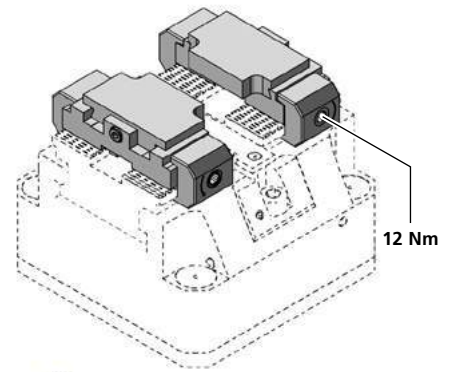
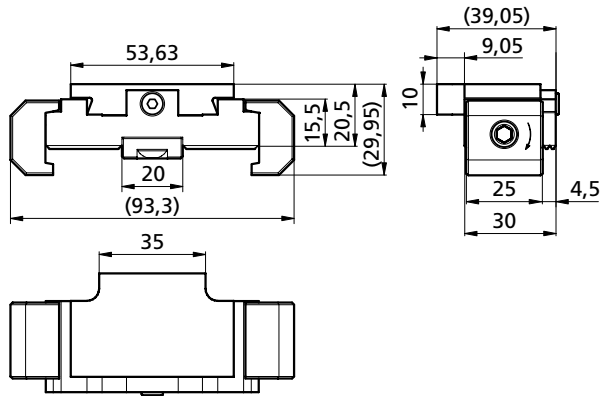

**PAND60-20.5UWB**

- 1 1x TK171294
- 2 1x TK180360
- 3 1x PCSP25L
- 4 1x PCSP25R
- 5 1x PCS10
- 6 1x PCGU2019
- 7 1x M5X8ISO7380
- 8 1x M4X8ISO4762

kg ~0,3

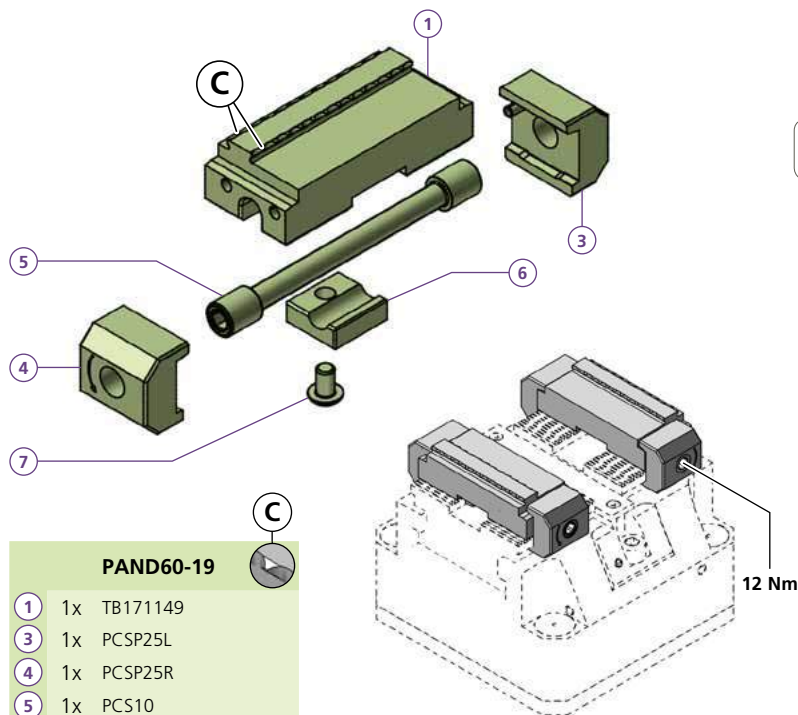
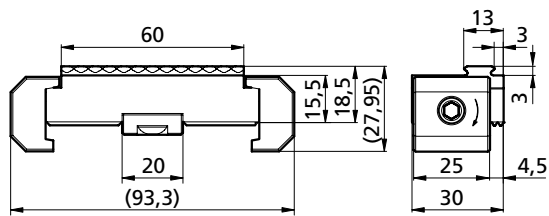

**PAND60-19**

- 1 1x TB171149
- 3 1x PCSP25L
- 4 1x PCSP25R
- 5 1x PCS10
- 6 1x PCGU2019
- 7 1x M5X8ISO7380

kg ~0,4

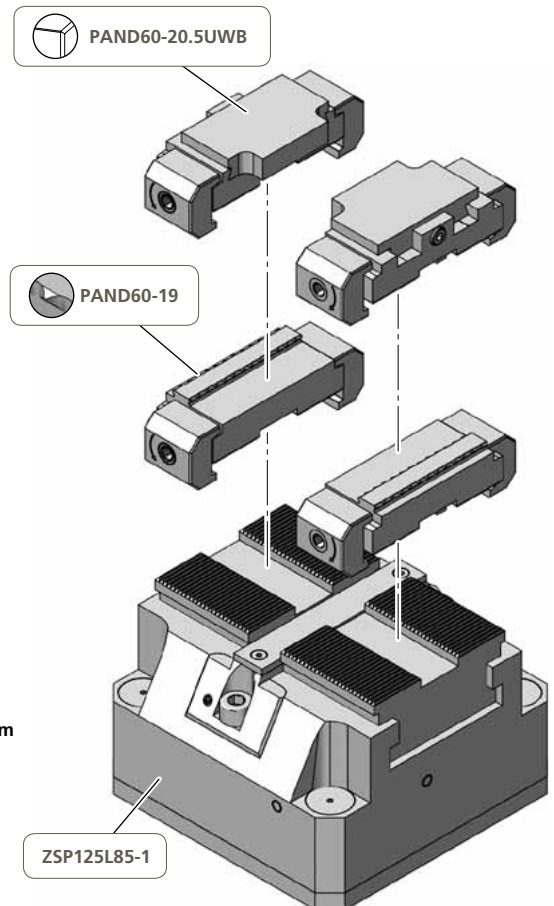

Bestellbeispiel / Ordering example: PAND60-20.5UWB



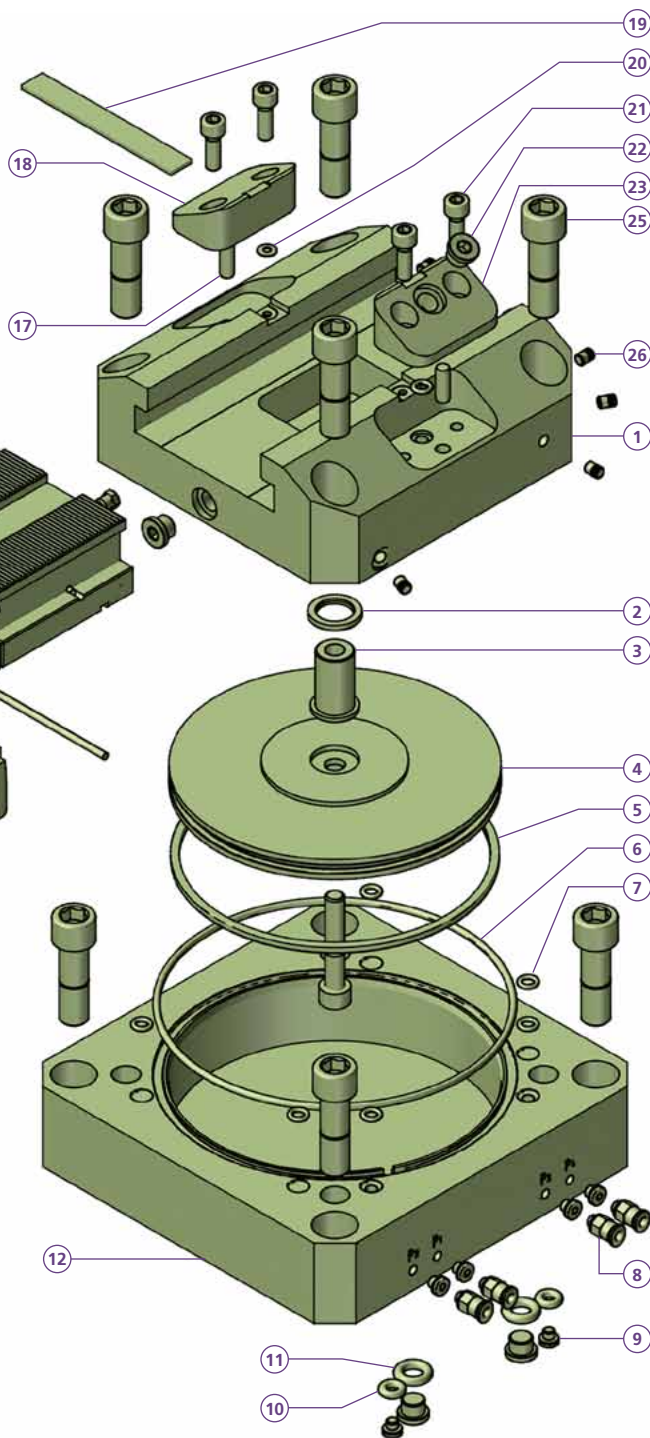
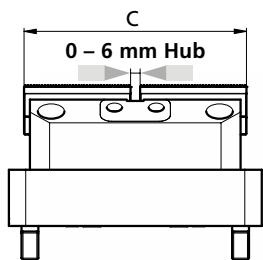
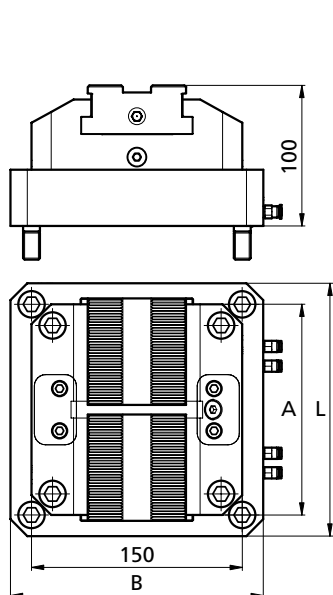

#### ZSP150L100

- 1 1x TB1900122
- 2 1x TN100525
- 3 1x TB140209
- 4 1x TB190092
- 5 1x TN100595
- 6 1x TN100894
- 7 7x TN100013
- 8 4x TN100596
- 9 6x TN100914
- 10 2x TN100917
- 11 2x TN100592
- 12 1x TB190125
- 13 2x TB190087
- 14 1x TB190085
- 15 2x TN100021
- 16 2x TB190123
- 17 2x TN100453
- 18 1x TB190095
- 19 1x TB190086
- 20 2x TN100916
- 21 4x **M6X18ISO4762**
- 22 5x TN100014
- 23 1x TB190094
- 24 8x TWPAS1240
- 25 5x TN100009

A = 150  
L = 180  
B = 180  
kg ~16



Bedienungsanleitung zu diesem pneumatischen Zentrischspanner  
Operating instructions for this pneumatic self centering vise

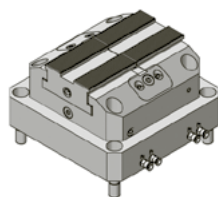

Bedienungsanleitung zu diesem pneumatischen Zentrischspanner  
Operating instructions for this pneumatic self centering vise

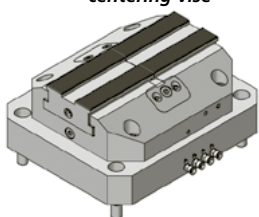

#### ZSP200L100

- 1 1x TB190083
  - 12 1x TB190091
  - 16 2x TB190084
- A = 200  
L = 240  
B = 200  
kg ~24,5

#### ZSP250L100

- 1 1x TB190083
  - 12 1x TB190091
  - 16 2x TF190780
- A = 200  
L = 240  
B = 200  
C = 250  
kg ~25,5



Bedienungsanleitung zu diesem pneumatischen Zentrischspanner  
Operating instructions for this pneumatic self centering vise

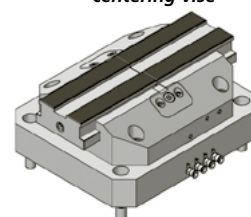

Spannkraft siehe Seite  
Clamping force see page

161

Bestellbeispiel / Ordering example: ZSP150L100

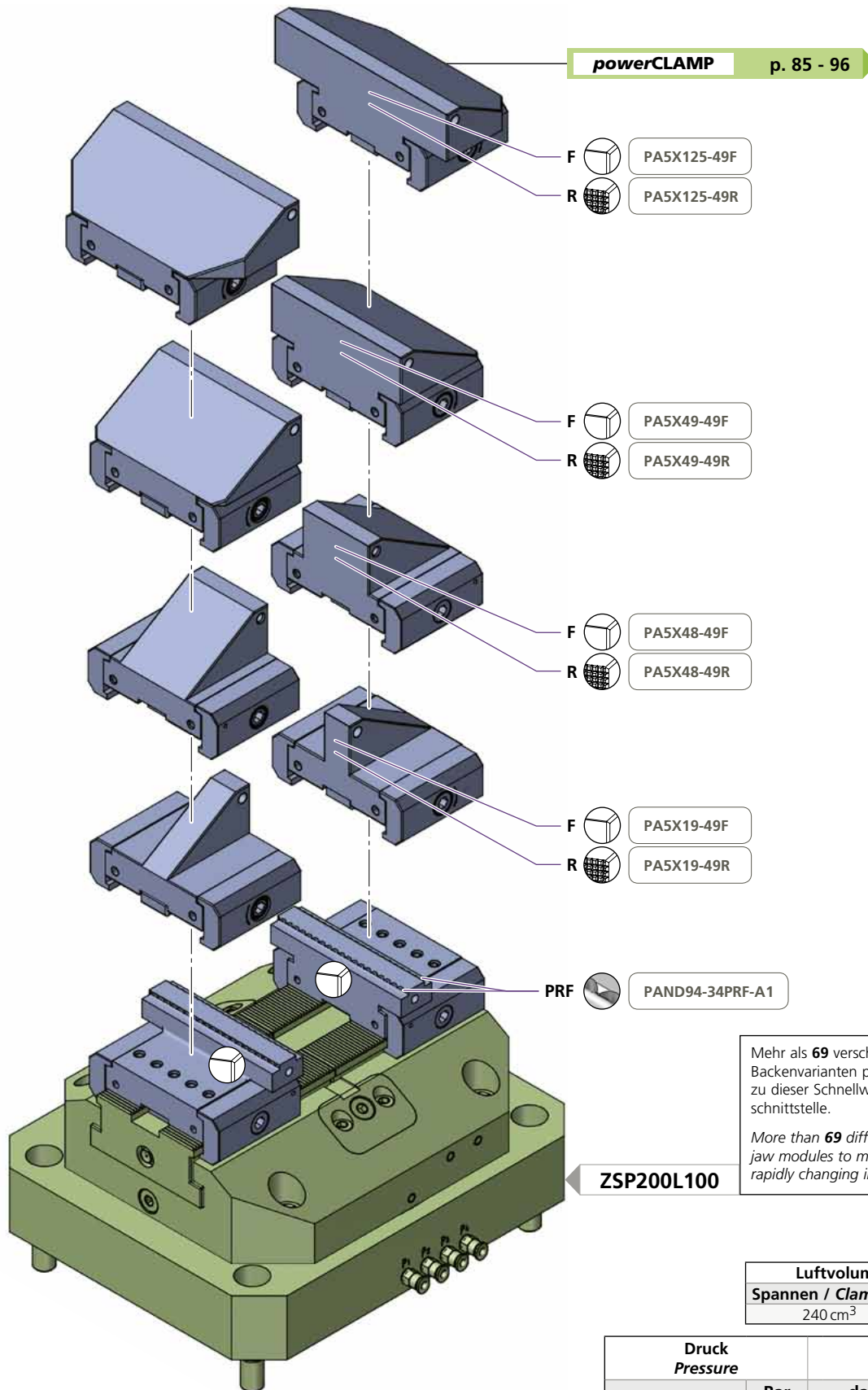

Mehr als **69** verschiedene Backenvarianten passend zu dieser Schnellwechsellchnittstelle.  
 More than **69** different jaw modules to match this rapidly changing interface.

Luftvolumen / Air volume	
Spannen / Clamping	Lösen / Loosen
240 cm <sup>3</sup>	243 cm <sup>3</sup>

	Druck Pressure		Spannkraft Clamping force		
	Bar		~daN	~(lb)	~t
Druckübersetzer Pressure intensifier 1:2	5	=	1'100	2'420	1,1
	8	=	1'500	3'300	1,5
	10	=	2'000	4'400	2,0
	12	=	2'400	5'290	2,4

Bestellbeispiel / Ordering example: 1 x **ZSP200L100** & 2 x **PA5X48-49F**

Separat bestellen / Separate order



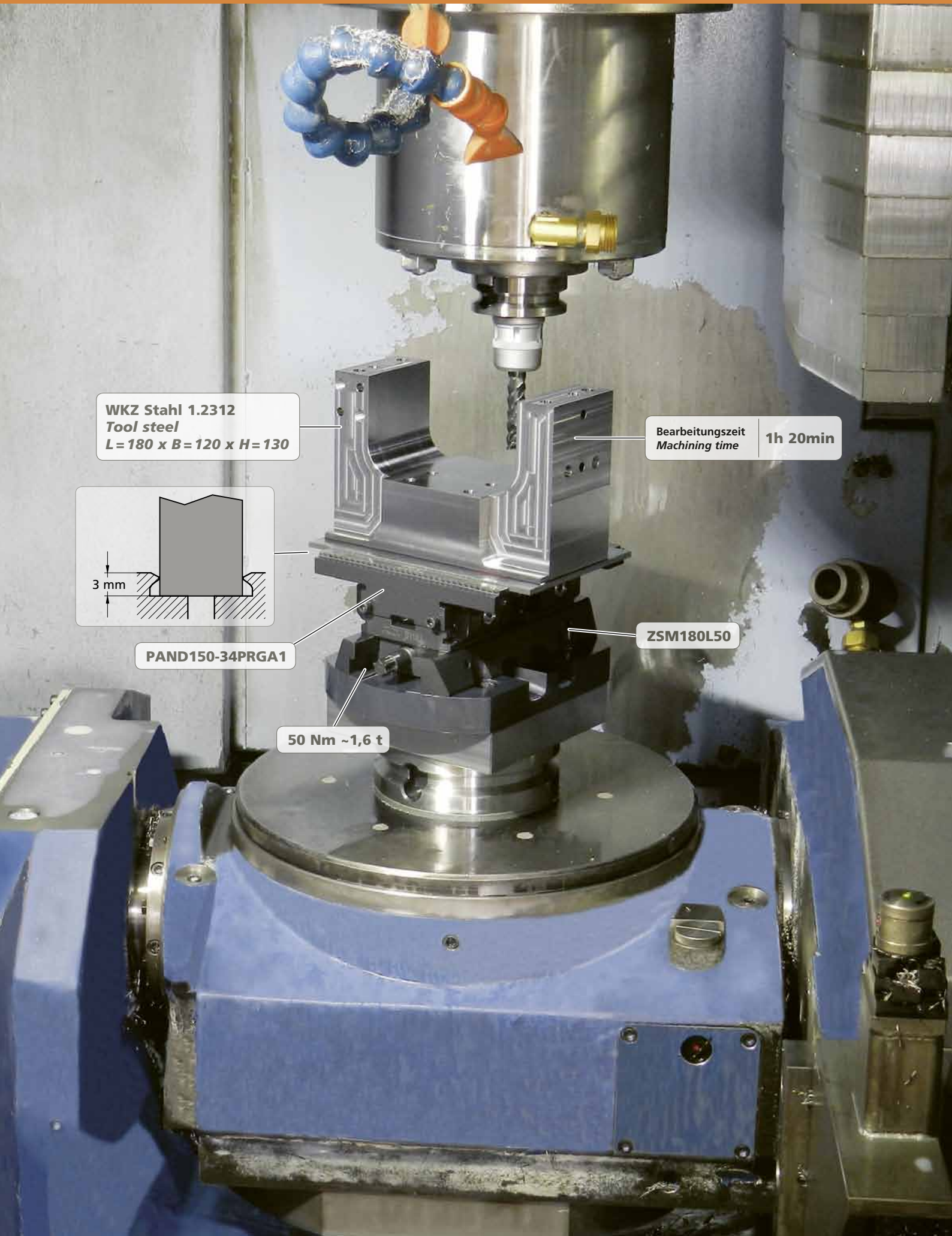

WKZ Stahl 1.2312  
Tool steel  
L = 180 x B = 120 x H = 130

Bearbeitungszeit  
Machining time 1h 20min

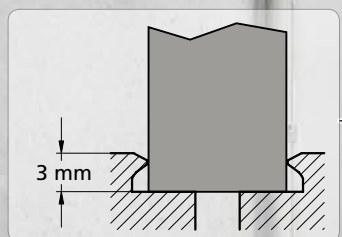

PAND150-34PRGA1

ZSM180L50

50 Nm ~1,6 t



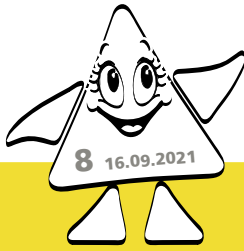

**microCLAMP**

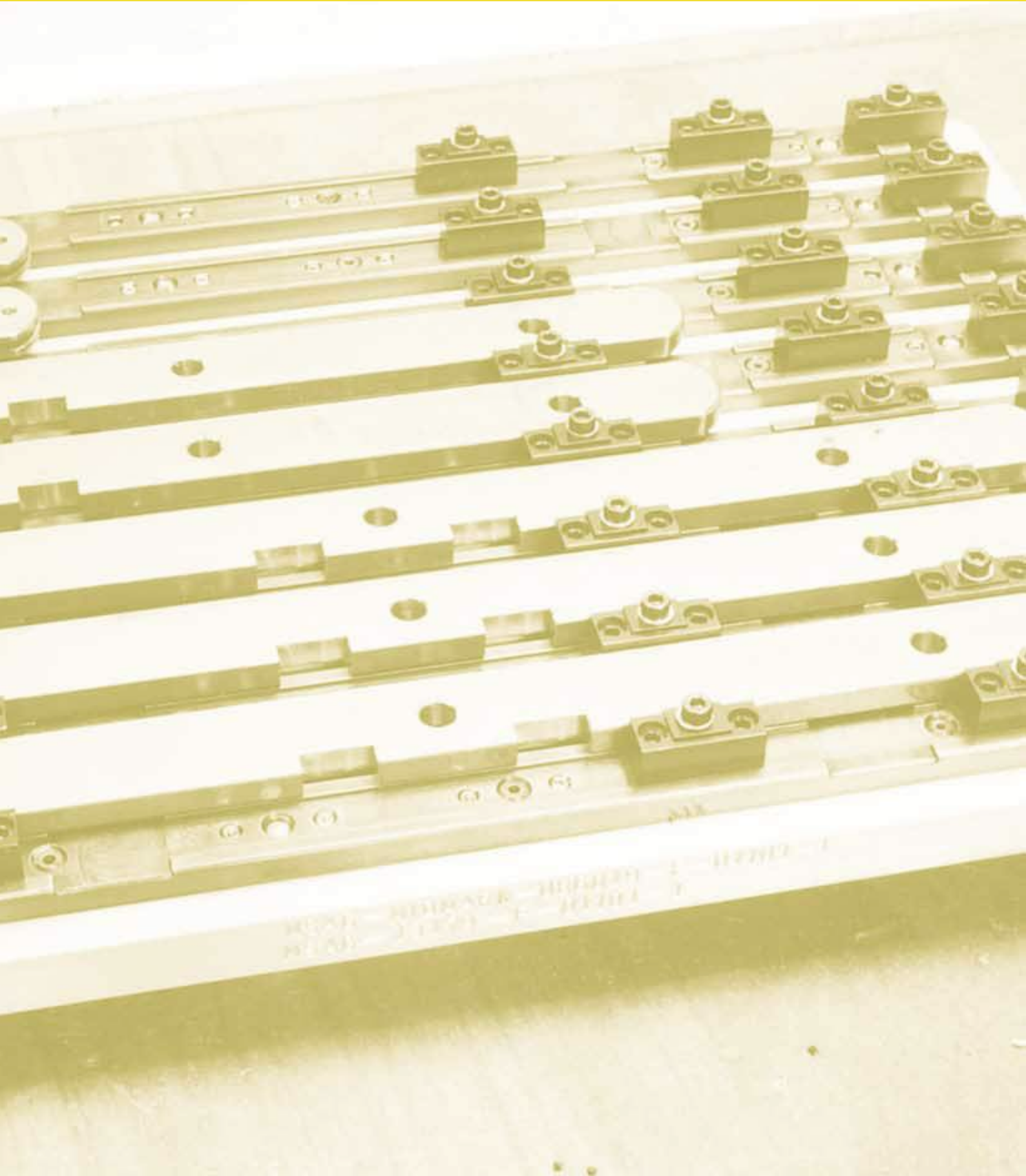

# compactCLAMP

Mehrfachspannsystem / Multiple workholding system

**Nur noch Ersatzteile und  
Nachlieferungen!  
Keine Compact Clamp  
Neuentwicklungen mehr!**

Beim Compact Clamp lassen sich die Spannmodule auf einer Basisschiene mittels Passstiften massgenau positionieren. Die Schienen sind mit einem Lochraster mit 7,5 mm Teilung, die Spannmodule mit einer 10 mm-Teilung versehen. Dank Anwendung des Nonius-Prinzips entsteht ein kleinstmöglicher Positionierschritt von 2,5 mm. Bei einem Backenhub von 4 mm ist es somit möglich, an jedem beliebigen Punkt der Schiene nullpunktbezogen zu spannen. Ab 20 mm ist die Bearbeitung von drei Seiten möglich. Da das Spannmodul mit vier Schrauben in den T-Nuten verankert wird, ist es sinngemäss auch möglich, an Stelle der Original-Spannmodule individuelle Vorrichtungen und Sonderbacken zu befestigen. Das Compact Clamp Spannsystem ist ein System für Tüftler. Praktisch keine Spannprobleme bleiben damit ungelöst. Dafür sind die Umrüstzeiten etwas länger als beim Power Clamp. Compact Clamp-Basisschienen sind in den Längen 113 - 750 mm lieferbar. Die angebotenen Befestigungsraaster sind 40 und 50 mm. Neben den Stahlschienen werden für leichte Arbeiten auch Schienen aus Aluminium hergestellt.

**Only spare parts and  
additional deliveries! No  
more new Compact Clamp  
developments!**

*In the Compact Clamp, the vise modules are positioned precisely on a base rail by means of alignment pins. On the base rail, positioning holes are located on a 7,5 mm grid, while on the vise module there is one with a 10 mm spacing. Following the vernier principle, the smallest possible positioning step is therefore 2,5 mm. With a jaw movement of 4 mm it is therefore possible to clamp the workpiece in any desired position with a known distance to program Zero (original datum face). From 20 mm up, three sided machining is possible. Special jaws or dedicated fixtures may easily be bolted onto the rails in place of standard vise modules if the need arises. They may be anchored in the T-slots and located by using alignment pins in the positioning holes. Hence the Compact Clamp is the ideal workholding system for "do it yourself" customers. Change over times are longer than with the Power Clamp, though. Available Compact Clamp base rails lengths: 113 - 750 mm. The fastening grids on the rails are 40 and 50 mm. In addition those made of steel we also produce rails made of aluminum for light work.*

Sie können den Katalog unter der folgenden  
Webadresse herunterladen!

You can download the catalogue at the  
web address below!

[www.triag-int.ch/wp-content/uploads/compactCLAMP.pdf](http://www.triag-int.ch/wp-content/uploads/compactCLAMP.pdf)

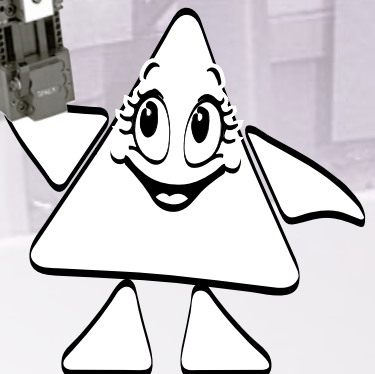





Einleitung | *Introduction* ..... 166 - 167

Anwendungsbeispiele | *Examples of application* ..... 168 - 171



Spannkraft und Drehmoment | *Workholding force and torque* ..... 173

Vorrichtungsbau - Präge- und Anschlagmodule (Linear)  
*For dedicated fixture - stamping- and end modules (linear)* ..... 174 - 176

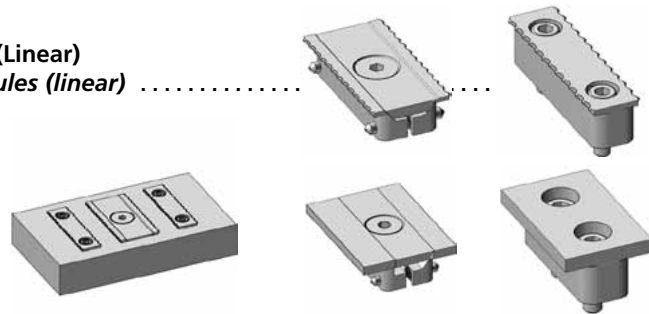

Niederzugspannmodule | *Pull down clamp modules* ..... 177 - 195

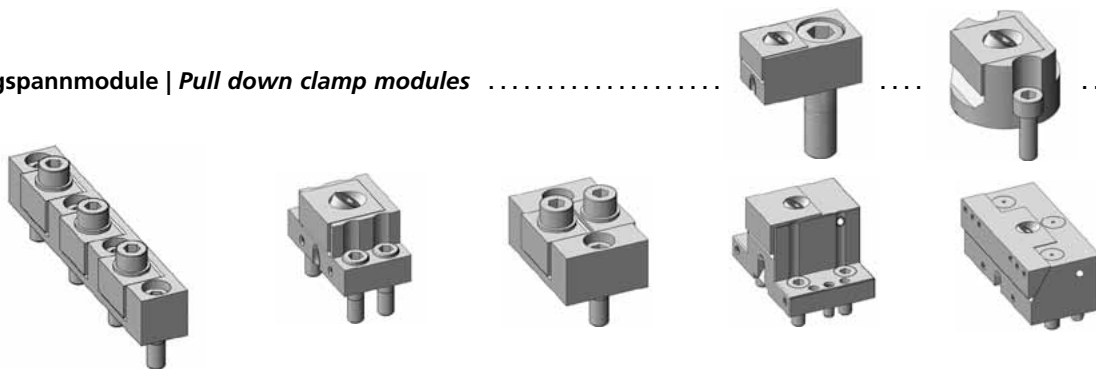

Linearspannmodule | *Linear clamping modules* ..... 196 - 203

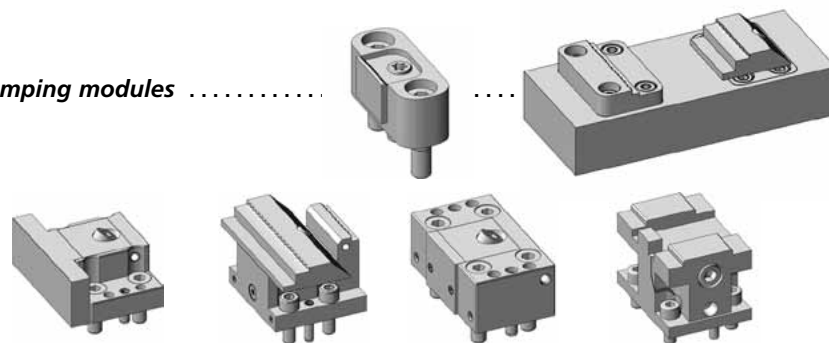

Zubehör | *Accessories* ..... 204 - 205







Zum Aufbau kundenspezifischer Sondervorrichtungen für höchste Werkstückdichte im Arbeitsraum von Bearbeitungszentren ist das Spannsystem Micro Clamp ausgelegt (Spezielle Anschlagbacken, siehe Bild). Sehr kompakte Spannmodule mit Prägebacken verwirklichen eine zuverlässige Aufspannung bei nur etwa 2 mm Verlust an Rohmaterial

*Clams for dedicated fixtures for high density to get your best output from your machine. Clamping modules in different sizes and shapes and jaws with serrations also flat and carbide coated are available.*

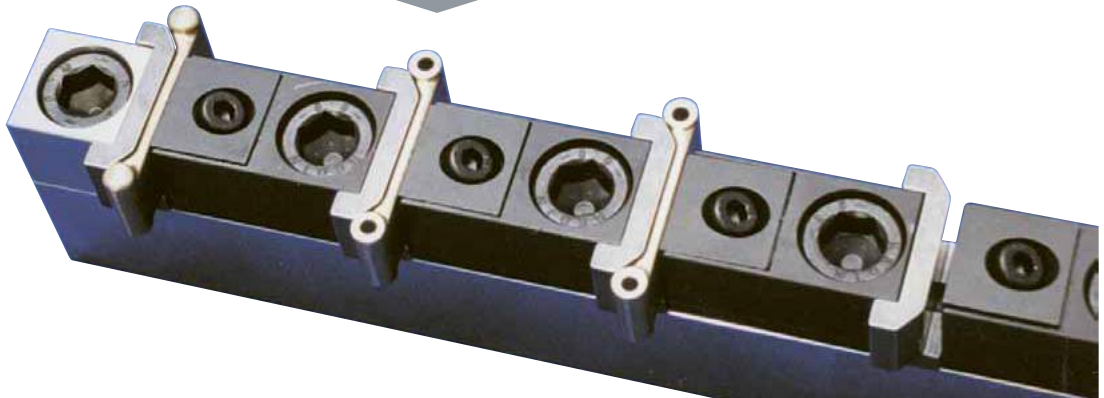

**Kleinst-Spannmodule für den Vorrichtungsbau. *Extremely small clamping modules for dedicated fixtures.***

**Hohe Spanndichte**

Die Spannmodule haben auf der Vorderseite eine Spannbacke, die Rückseite ist zu den Befestigungsbohrungen massgenau geschliffen oder gefräst. Damit kann diese Anschlagfläche für das folgende Werkstück genutzt werden. Diese Anordnung lässt eine sehr hohe Spanndichte zu. Beim kleinsten Micro Clamp-Modul sind nur 15 mm Spannabstand erforderlich.

***High workholding density***

*These clamping modules have a clamping jaw on the front, while rear is precisely ground or milled with reference to the fixing holes. This means that it can be used as a datum face for the following workpiece. This arrangement allows very high clamping densities. Only 15 mm clamping clearance is needed between workpieces using the smallest Micro Clamp module.*

- Maximale Spannkraft der Module 2,8t (28'000N)
- Benötigter Platz zwischen den Werkstücken ab 15 mm
- Spannhub ab 1,5 mm
- Genaue Positionierung durch Passschrauben und Positionierstifte

- *Clamping force up to 2,8t (28'000N)*
- *Space between workpieces only 15 mm*
- *Stroke of jaw from 1,5 mm*
- *Precise positioning by ground shoulder screws or dowel pins*



Ein grosses Angebot an verschiedensten Spannmodulen.  
*A wide range of clamp modules in different sizes are available*

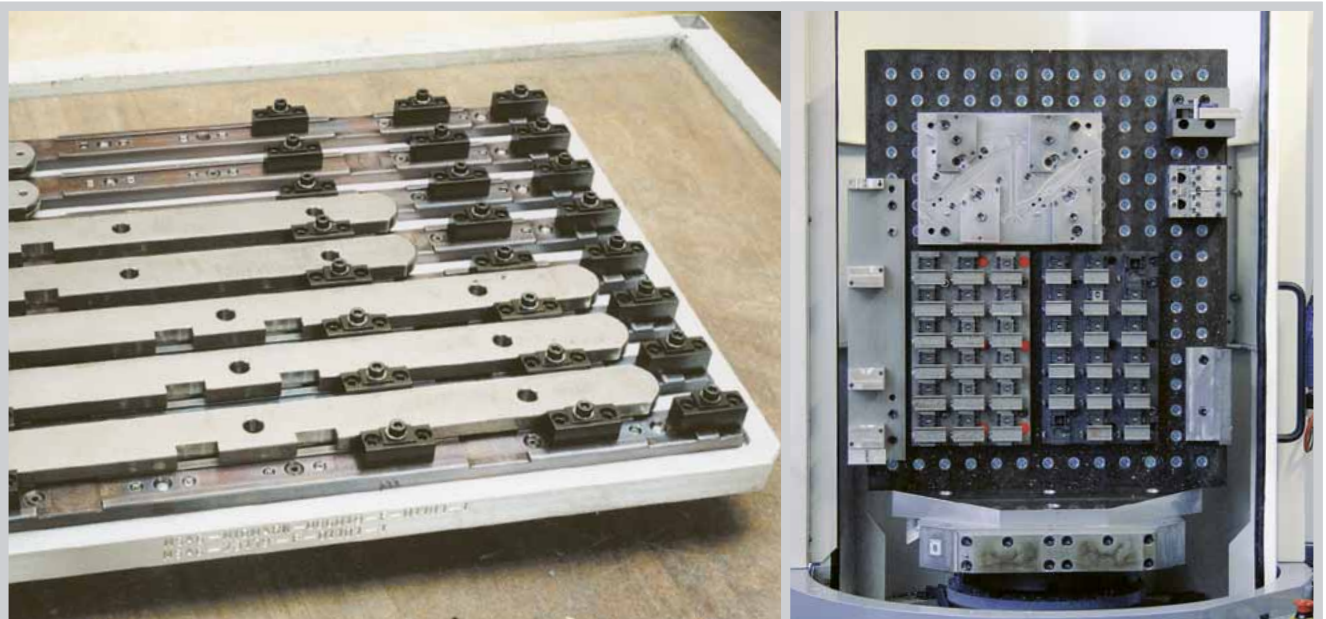

Hohe Spanndichte für Werkstücke in grossen Stückzahlen.  
*High density fixture plates for repeating orders in high quantities*

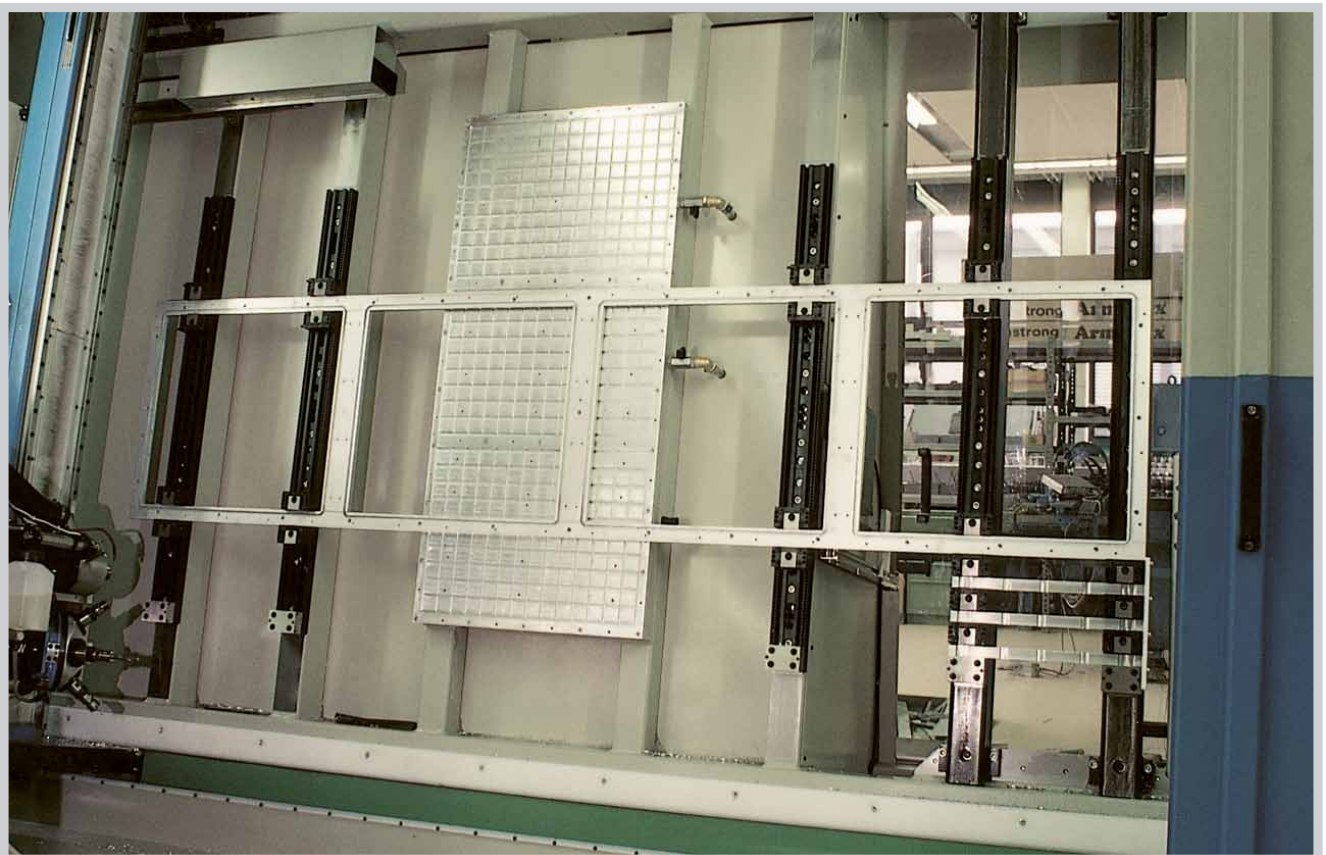



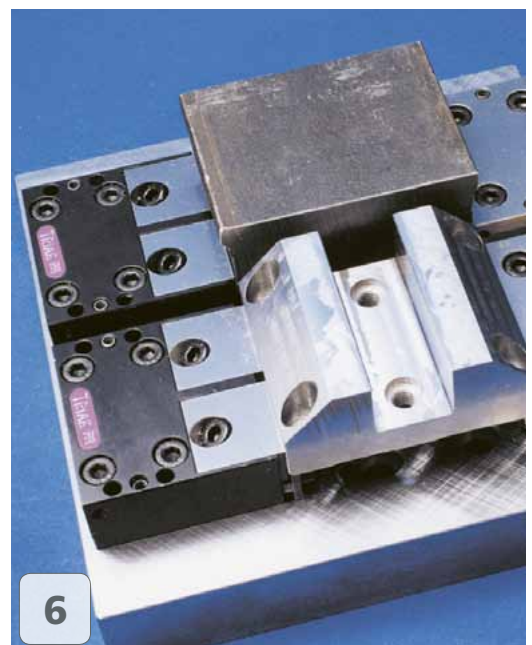
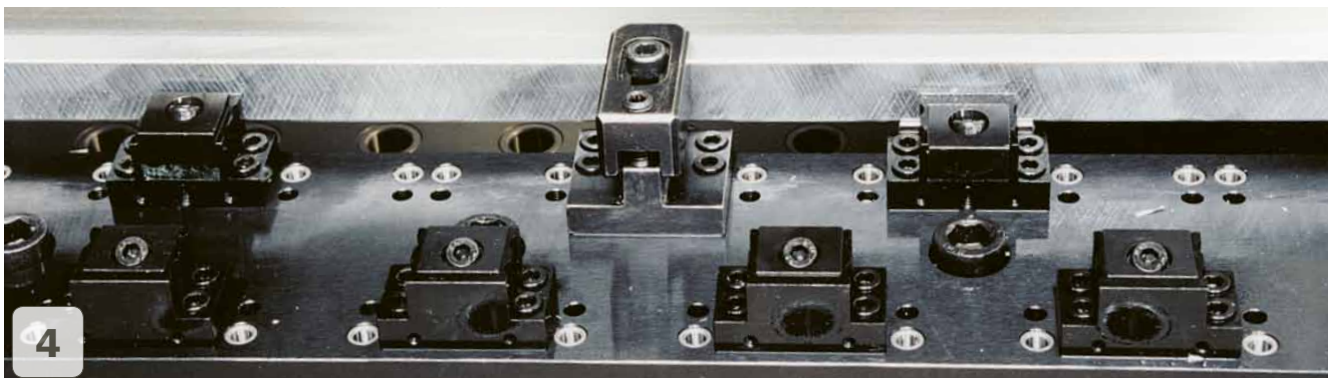
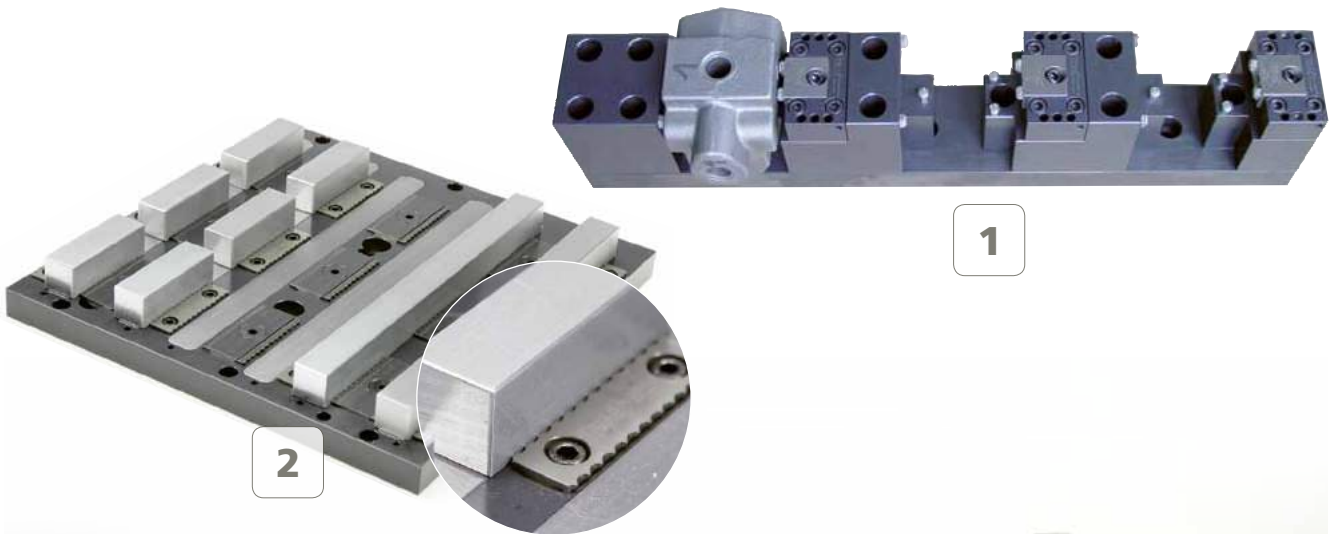





7 72 Teile sind hochgenau gespannt unter 10 my. Die Vorrichtungen sind auf einem EROWA ITS O-Punkt Spannsystem aufgebaut  
72 parts are clamped within 10 microns the clamp fixtures are set up on a EROWA ITS palleting system

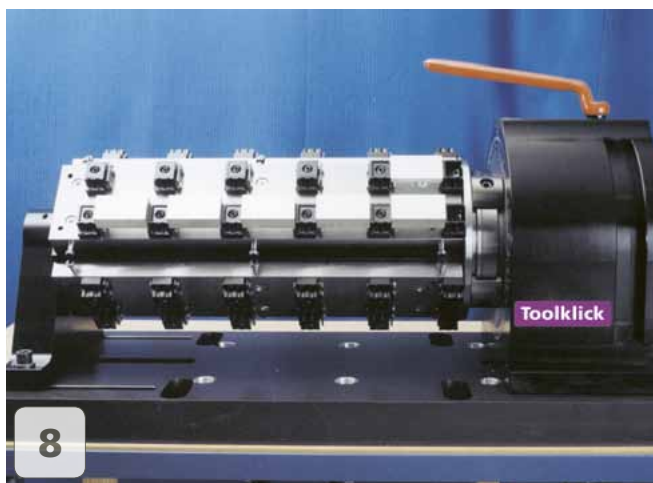

8

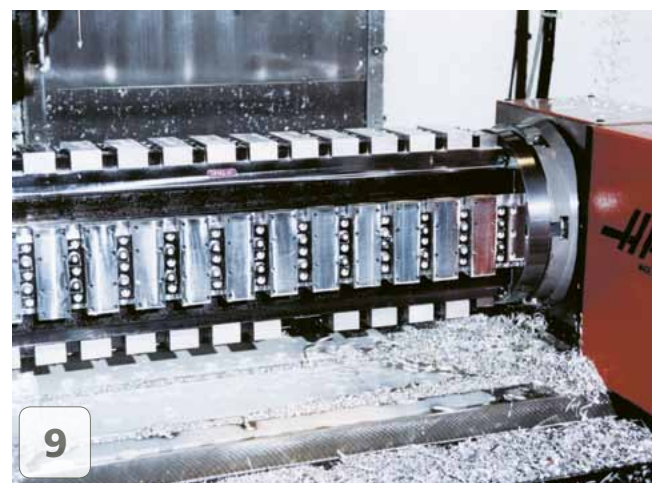

9

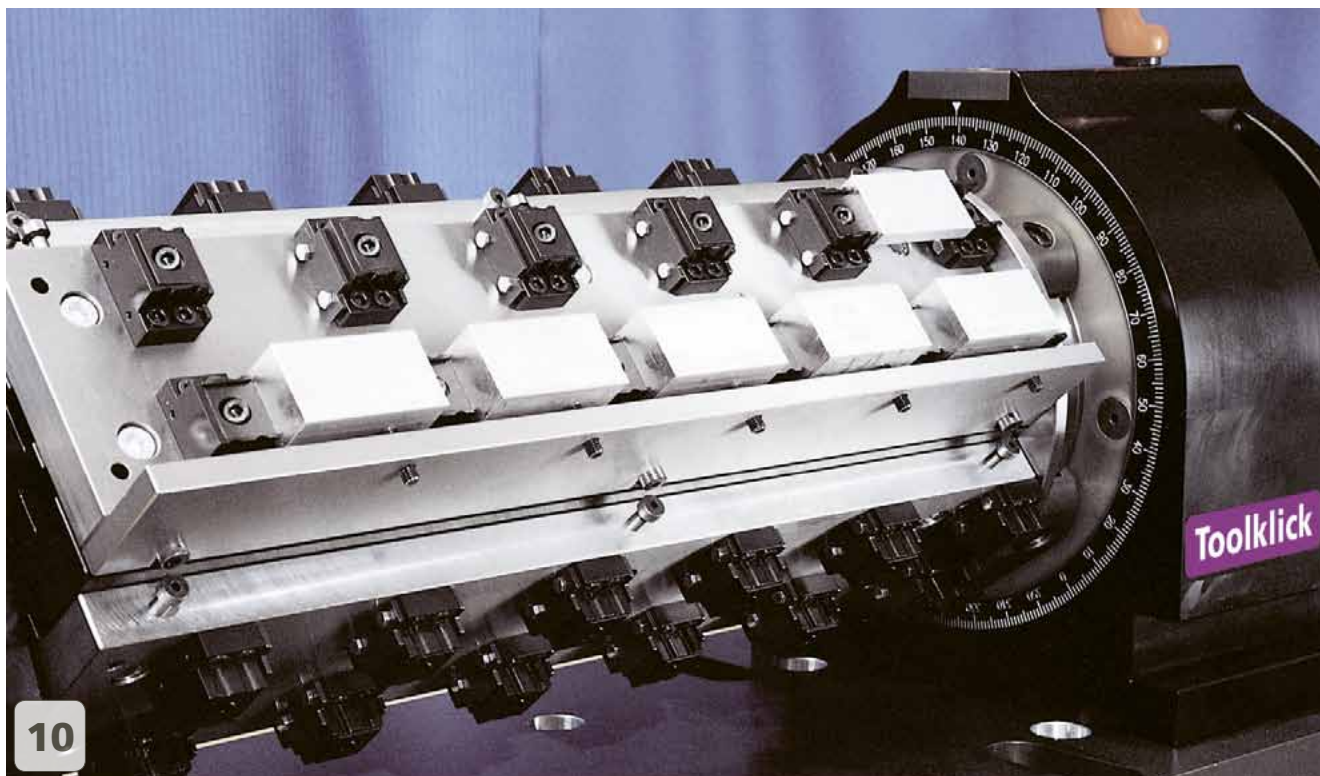

10





**11** 84 Teile sind gespannt mit Micro Clamp und werden jeweils nachts unbemannt produziert  
*84 parts are clamped with Micro Clamp and are machined always at night unmanned*



**12**

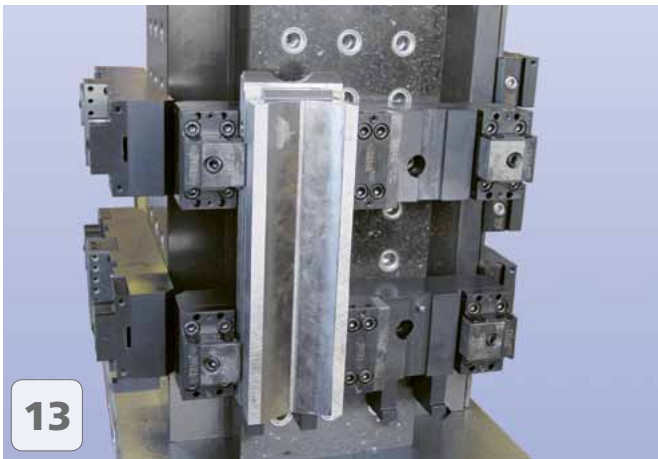

**13**



**16**

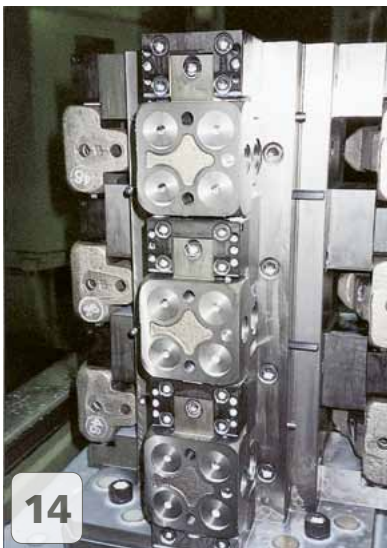

**14**



**15**



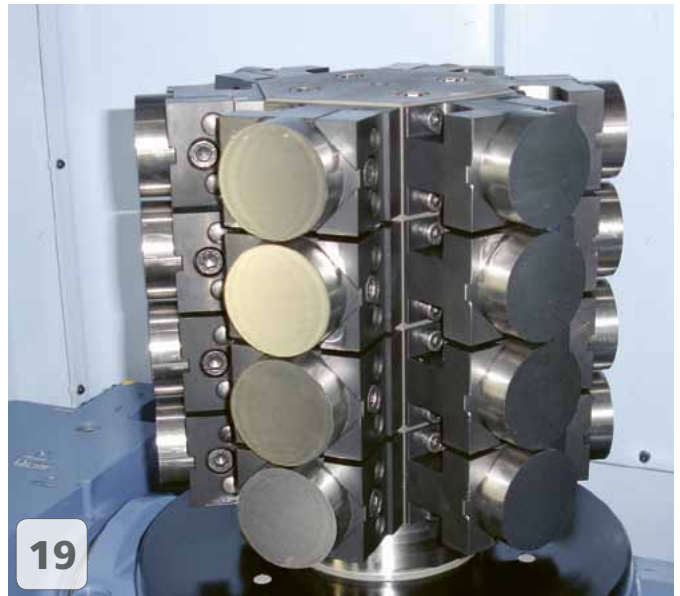
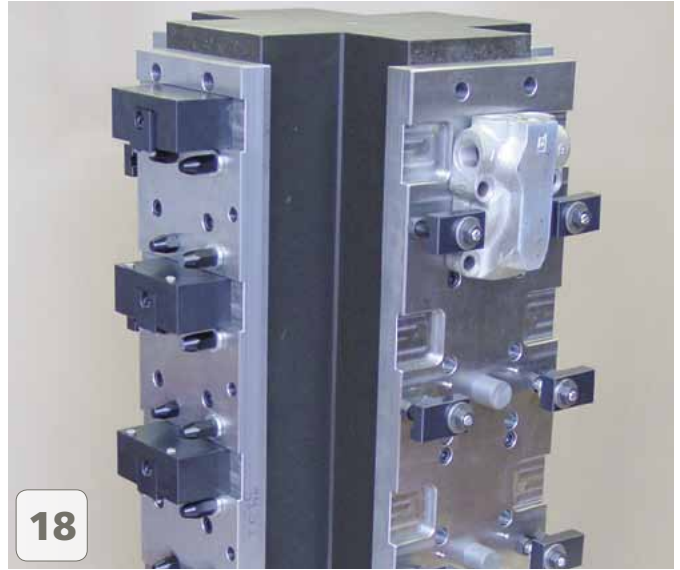





System System		bei Anschlagmodulen for end module		Modulnutzbreite Module clamping width		Modulnutztiefe / -höhe Module clamping depth or height	
A	Apto Clamp	N	nitriert nitrided	19 25 26 34 43 48 58 61 68 78 94 125		MS: Tiefe Depth	
P	Power Clamp	D	durchgehärtet through hardened				
C	Compact Clamp	<b>bei Spannmodulen for vice modules</b>					
M	Micro Clamp	1	Anzahl Spannbacken Number of jaws				
V	Vorrichtungsbau module Workholding modules for dedicated fixtures	2					
		3					
		-	keine Spannbacke no clamping jaw				

**M S 1 F 35 N 14 -01**

Modultyp Type of module	
A	Anschlagmodul End module
S	Spannmodul Clamping module
T	Trägermodul Supporting module
R	Rohling / Rundes Modul Blank / Round mod- ule
V	Vertikalspannmodul Vertical clamp

Anschlagfläche der Module Datum face	
F	Anschlagfläche glatt Datum face flat
R	Anschlagfläche geriffelt Datum face double serrated
D	eine Seite glatt, eine Seite geriffelt one face flat, one face double serrated
G	Anschlagfläche gerillt Datum face serrated
X	spezielle Ausführung special execution
5X	5axes Clamp
P	prägen stamping

Backenhub Stroke of clamping jaw	
N	Niederzug Pull down
L	linear / parallel linear / parallel
-	ohne Spannbacke no clamping jaw

Spannbackentyp Type of clamping jaw	
B01	Spannbacke Clamping jaw
-	
B151	
-01	Modul ohne Spann- backen Module without clamp- ing jaw
-	
-150	



# ACHTUNG / CAUTION

**WICHTIG:** Die im Micro Clamp Kapitel angegebenen Drehmomente sind die absoluten Maximalwerte. Über die Spannkraften gibt die untenstehende Tabelle Auskunft.

**IMPORTANT:** The torque numbers specified in the Micro Clamp chapter represent the absolute maximum. The table at the bottom of this page provides further information on the workholding forces.

Niederzug-Spannmodule Pull down module	MC-Module	Schraube Screw	Drehmoment Torque		Spannkraft Workholding force		
			Nm	(lb-ft)	~daN	~(lb)	~t
	MR1F 30N23 -07	M5	10	7,4	= 1020	2250	1,02
	MS1F 22N40 -07		10	7,4	= 1020	2250	1,02
	MS1F 24N22 -07		10	7,4	= 1020	2250	1,02
	MS1R/F 25N25 -13	M6	15	11	= 1520	3350	1,52
	MS1F 35N14 -01	M5	10	7,4	= 1020	2250	1,02
	MS1F 35N22 -01		10	7,4	= 1020	2250	1,02
	MS2X 25N23 -01		10	7,4	= 1020	2250	1,02
	MS2F 60N14 -01		10	7,4	= 1020	2250	1,02
	MS3F 85N14 -01		10	7,4	= 1020	2250	1,02
	VS1R 19N35 -20		M6	15	11	= 1520	3350
	VS1R 26N35 -26	M8	25	18,4	= 2100	4630	2,10
	VS1R 38N50 -60		25	18,4	= 2100	4630	2,10
	VS1R/F 41N30 -60		25	18,4	= 2100	4630	2,10
	VS1R/F 80N30 -36		25	18,4	= 2100	4630	2,10
	VS1R 80N50 -36		25	18,4	= 2100	4630	2,10
	VS1R/F 80N30 -60		25	18,4	= 2100	4630	2,10
	VS1R 80N50 -60		25	18,4	= 2100	4630	2,10
	VS1R/F 125N49 -95		40	29,5	= 2800	6170	2,80
VS2R 80N30 -60	M10	25	18,4	= 2100	4630	2,10	
VS2F 90N30 -60		25	18,4	= 2100	4630	2,10	
	MS1F (MS1R) 35L14 -152	M6x0,5	10	7,4	= 570	1260	0,57
	MS2P (MS2P) 58L14 PRG15	M8	15	11	= 600	1320	0,6
	MS2F (MS1F) 58L14 W251		15	11	= 600	1320	0,6
	VS1R 26L35 -31		25	18,4	= 2100	4630	2,10
	VS1R/F 41L30 -51	25	18,4	= 2100	4630	2,10	
	VS1R/F 80L30 -51	25	18,4	= 2100	4630	2,10	
	VS1X 68L20 -105	40	29,6	= 1600	3530	1,60	
	VS1X 59L60 K	M10	50	37	= 1880	4140	1,88
	VS1X 59L60 H5		50	37	= 1640	3620	1,64

**Die Spannbacken und Schrauben regelmässig fetten!**  
*Lubricate clamping jaw and screw regularly with grease!*

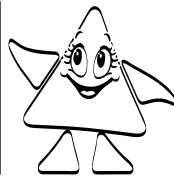

Schraube Screw	Drehmoment Torque		Spannkraft Workholding force		
M5 + M6	4	3	= 500	1100	0,50
	5	3,7	= 580	1280	0,58
	6	4,4	= 690	1520	0,69
	7	5,2	= 780	1720	0,78
	8	5,9	= 880	1940	0,88
	9	6,6	= 980	2160	0,98
M6	10	7,4	= 1020	2250	1,02
	12	8,9	= 1220	2690	1,22
	14	10,4	= 1450	3200	1,45
M8	15	11	= 1520	3350	1,52
	4	3	= 410	900	0,41
	5	3,7	= 490	1080	0,49
	6	4,4	= 560	1250	0,56
	7	5,2	= 660	1460	0,66
	8	5,9	= 730	1610	0,73
	9	6,6	= 810	1790	0,81
	10	7,4	= 900	1980	0,90
M10	15	11	= 1520	3350	1,52
	20	14,8	= 1810	3990	1,81
	25	18,4	= 2100	4630	2,10
	10	7,4	= 400	880	0,40
	20	14,8	= 1400	3090	1,40
	30	22,1	= 2000	4410	2,00
40	29,5	= 2800	6170	2,80	



Keilspanner in weicher Ausführung zum Bearbeiten von Formbacken.

*Double angle clamps with soft jaws for making shaped forms.*

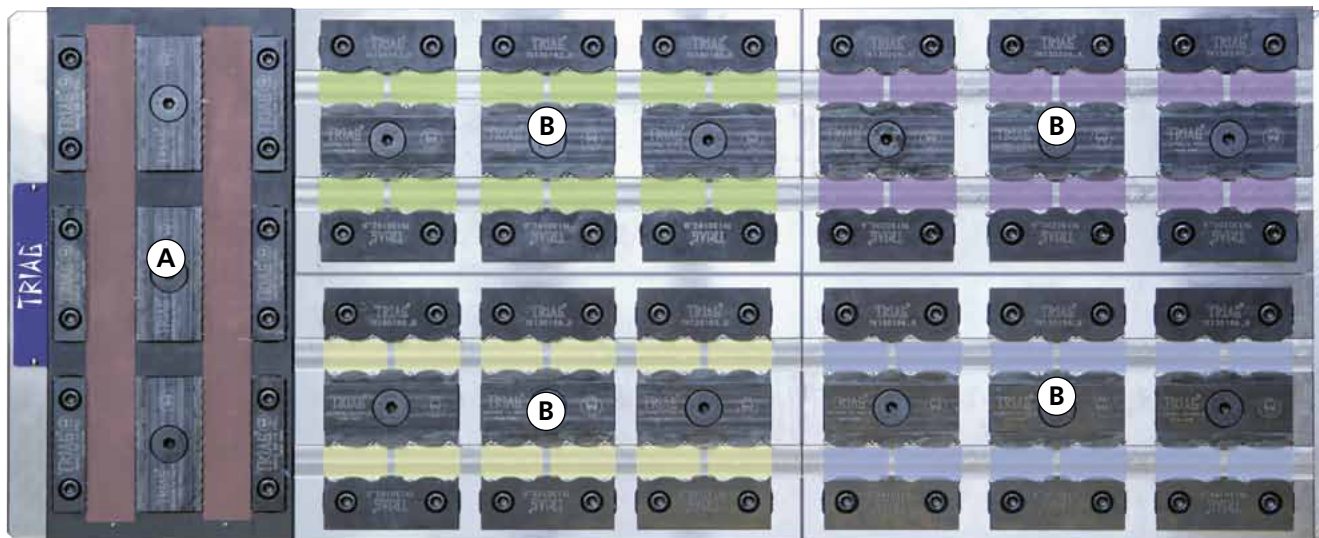

**A** Prägemarken Spanntiefe 1,8 mm  
 12 Werkstücke werden hergestellt  
*First clamp 12 parts with stamping jaws  
 clamping depth 1,8 mm*

**B** 4 x 12 verschiedene Teile werden in der  
 2. Spannung bearbeitet  
*4 times 12 different parts are machined  
 in the second operation*

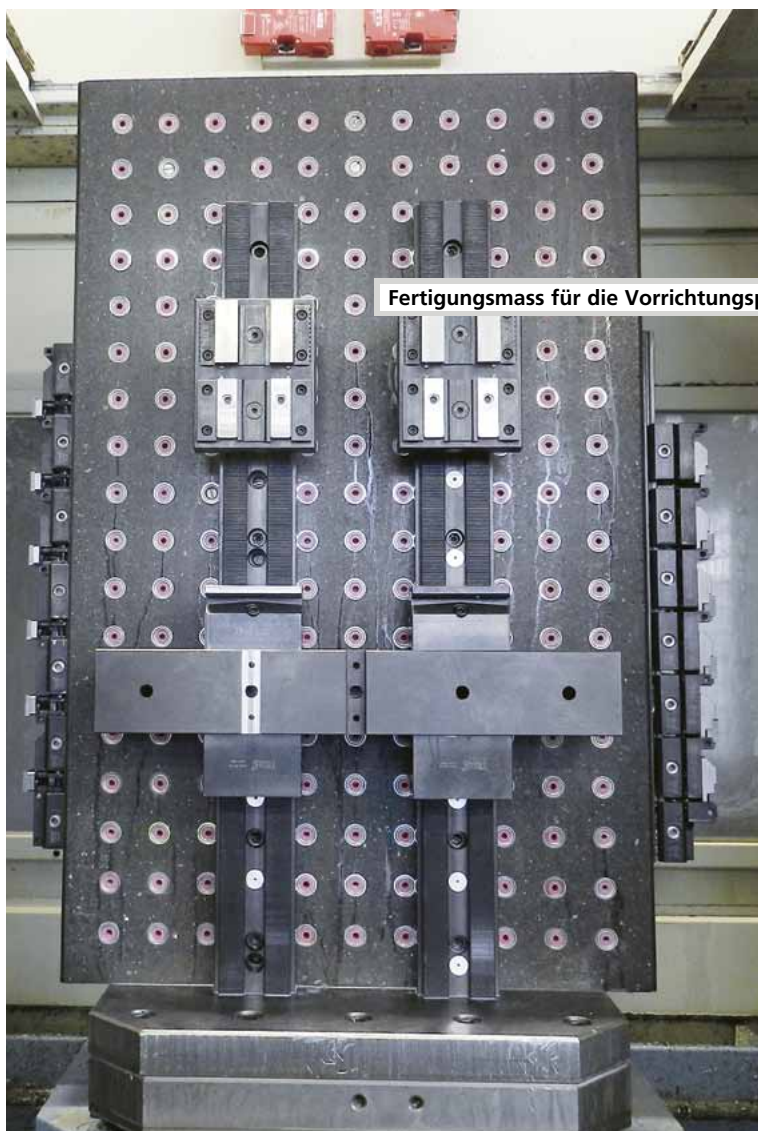

Fertigungsmass für die Vorrichtungplatte: / Machining data for the fixture plate: p. 175

**Fräser / Milling cutter**

Der abgebildete Fräser benötigt man für die Herstellung der «Kerben».  
 Siehe Fertigungsmasse für die Vorrichtungplatte Seite 175.

*The illustrated milling cutter is required for the production of "notches".  
 Manufacturing drawing for the fixture plate on page 175.*

45°	d	D	L1	H	z	L
<b>TK150057</b>	6	6,0	24,0	1,5	3	58

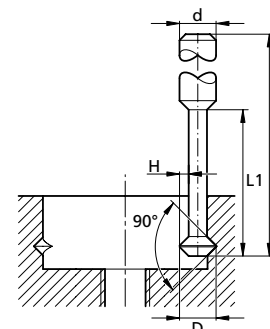



Fertigungsmasse für die Vorrichtungplatte / Machining data for the fixture plate

<p><b>Mass</b>  <b>X (X1) = B + 24 mm</b>  <b>Beispiel:</b>          Bauteilbreite = 14 mm</p> <p>Taschenabstand  <math>X = 14 + 24 = 38</math>          Das ergibt eine Einlegeluft von 0,8 mm          (Hub bis 2,7 mm)</p>	<p><b>Dimension</b>  <b>X (X1) = B + 24 mm</b>  <b>Example:</b>          Width of component part = 14 mm</p> <p>Distance of pocket  <math>X = 14 + 24 = 38</math>          This makes a play of 0,8 mm          (stroke till 2,7 mm)</p>	<p><b>Mass</b>  <b>X2 = B + 33,5 mm</b>  <b>Beispiel:</b>          Bauteilbreite = 14 mm</p> <p>Taschenabstand  <math>X = 14 + 33,5 = 47,5</math>          Das ergibt eine Einlegeluft von 0,8 mm          (Hub bis 2,7 mm)</p>	<p><b>Dimension</b>  <b>X2 = B + 33,5 mm</b>  <b>Example:</b>          Width of component part = 14 mm</p> <p>Distance of pocket  <math>X = 14 + 33,5 = 47,5</math>          This makes a play of 0,8 mm          (stroke till 2,7 mm)</p>

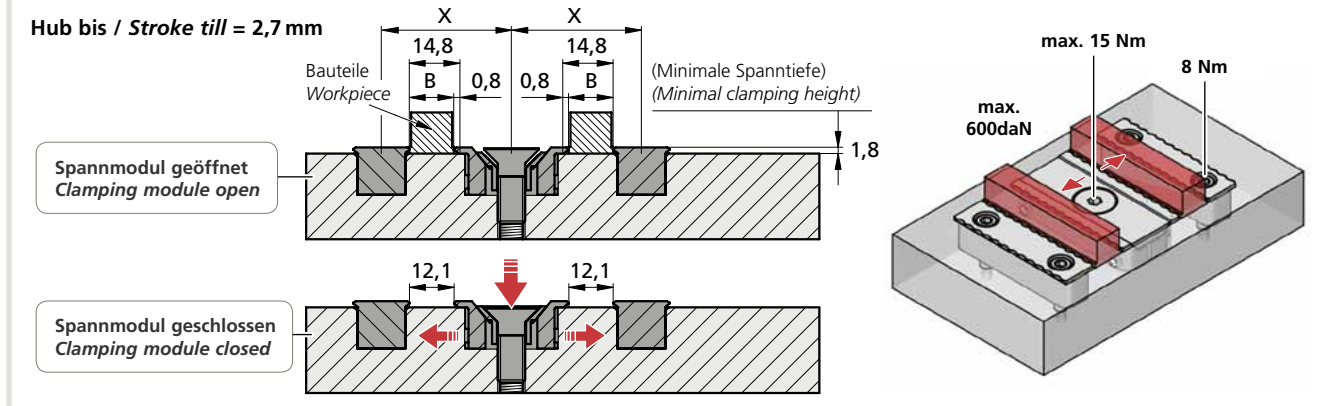

<p><b>MS2P58L14PRG15</b></p> <ul style="list-style-type: none"> <li>1 2x TK120225</li> <li>2 1x TK120227</li> <li>3 1x M8X22DIN7991</li> </ul> <p>Y 4,7 mm          i 57HRC          kg ~0,12</p>	<p><b>MS1P58L14PRG15</b></p> <ul style="list-style-type: none"> <li>1 1x TK120225</li> <li>2 1x TK120721</li> <li>3 1x M8X22DIN7991</li> <li>4 1x TK120720</li> </ul> <p>Y 4,7 mm          i 57HRC          kg ~0,12</p>	<p><b>MAND58-14PRG</b></p> <ul style="list-style-type: none"> <li>1 1x TK120226</li> <li>3 2x M5X16ISO4762</li> </ul> <p>Y 4,7 mm          i 57HRC          kg ~0,08</p>	<p><b>MAND58-14PRG6</b></p> <ul style="list-style-type: none"> <li>1 1x TB150282</li> <li>3 2x M5X16ISO4762</li> </ul> <p>Y 6,0 mm          i 57HRC          kg ~0,08</p>
---	--	--	---

**Zum Erstellen Ihrer individuellen Formbacke:**  
Schnittzeichnung zum Ermitteln der maximalen Bearbeitungsprofiltiefe  
**If a dedicated jaw is being machined:**  
Sectional drawing to determine the maximum machining depth

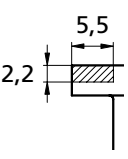

für / for TK120531 | TK120531 | TK120529 | TK160554

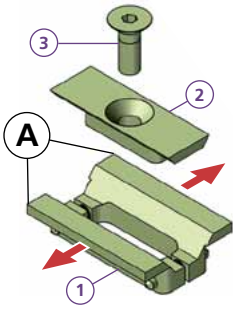
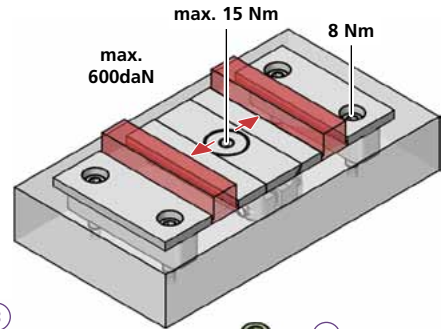

**MS2F58L14W251**

- 1 2x TK120531
- 2 1x TK120227
- 3 1x M8X22DIN7991

i \*

kg ~0,12

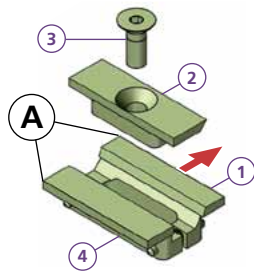

**MS1F58L14W251**

- 1 1x TK120531
- 2 1x TK120721
- 3 1x M8X22DIN7991
- 4 1x TH130566

i \*

kg ~0,12

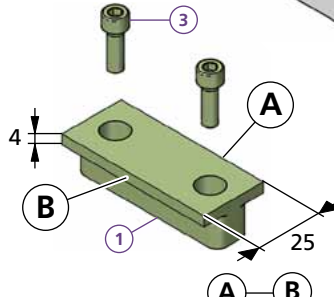

**MANF58-14W25**

- 1 1x TK120529
- 3 2x M5X16ISO4762
- i \*

**MANF58-14F25**

- 1 1x TK150033
- 3 2x M5X16ISO4762
- i HV700 x 0,2mm

kg ~0,11

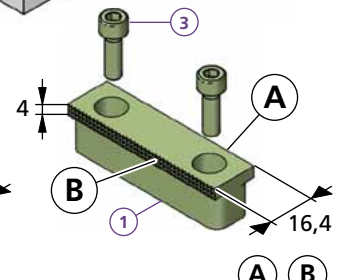

**MANF58-14RF**

- 1 1x TB160563
- 3 2x M5X16ISO4762

i HV700 x 0,2mm

kg ~0,11

**p. 175 Fertigungsmass für die Vorrichtungplatte: / Machining data for the fixture plate:**

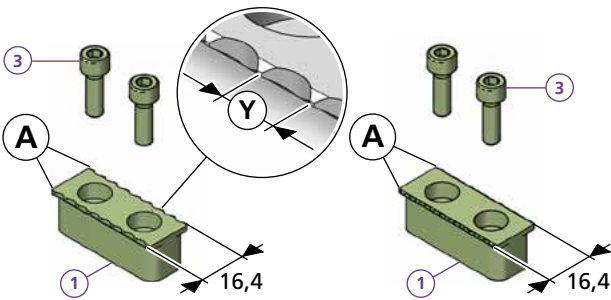

**MAND38-14PRG**

- 1 1x TB150234
- 3 2x M5X16ISO4762
- Y 4,7 mm

i 57HRC

kg ~0,08

**MAND38-14PRG6**

- 1 1x TB150283
- 3 2x M5X16ISO4762
- Y 6,0 mm

i 57HRC

kg ~0,08

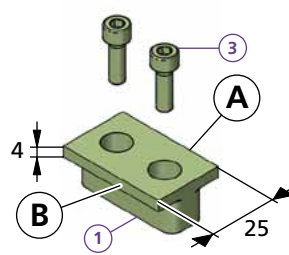

**MANF38-14W25**

- 1 1x TK160554
- 3 2x M5X16ISO4762
- i \*

**MANF38-14F25**

- 1 1x TK160553
- 3 2x M5X16ISO4762
- i HV700 x 0,2mm

kg ~0,08

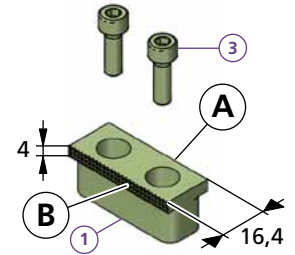

**MANF38-14RF**

- 1 1x TB170062
- 3 2x M5X16ISO4762

i HV700 x 0,2mm

kg ~0,08

**Fertigungsmass für die Vorrichtungplatte**  
**Machining data for the fixture plate**

für / for TB150234 | TB150283 | TK160554 | TK160553 | TB170062



# Spannmodule

## Clamping module MV1F20L35BV1

microCLAMP

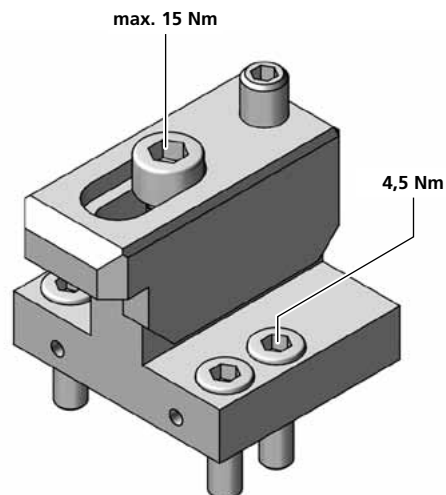
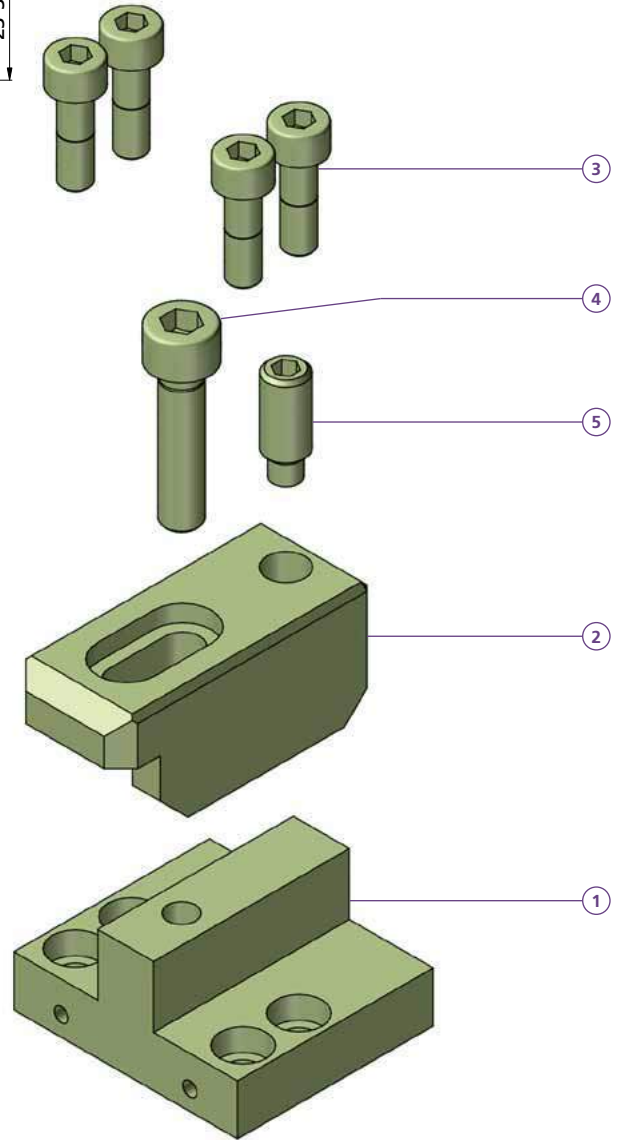
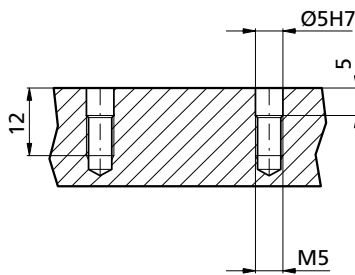
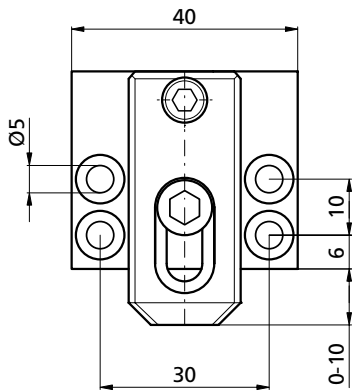
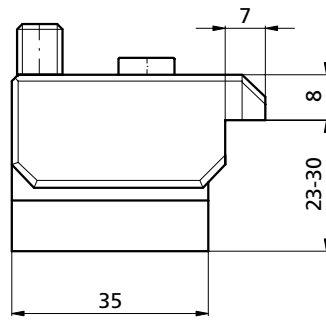
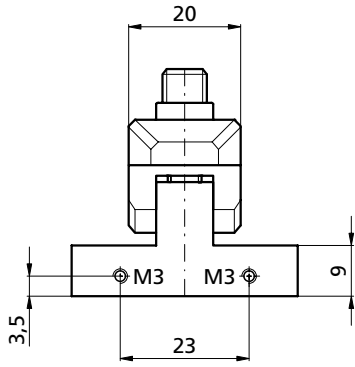

MV1F20L35BV1	
1	1x TF140710
2	1x BV1
3	4x M550
4	1x M6X25ISO4762
5	1x M8x20ISO4028
kg	~0,225

Bestellbeispiel / Ordering example : MV1F20L35BV1





# MR1F30N23-07

microCLAMP

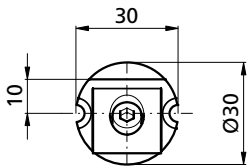
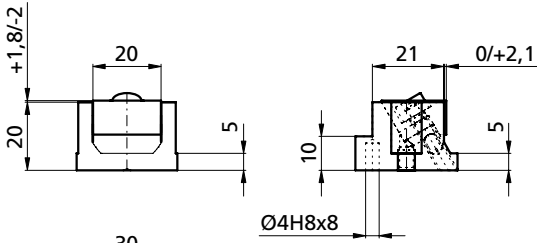
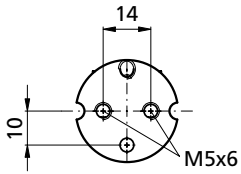

Version 2

Version 1

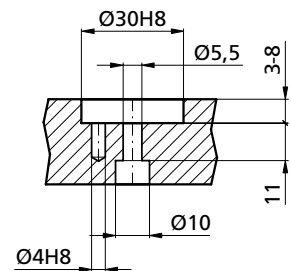
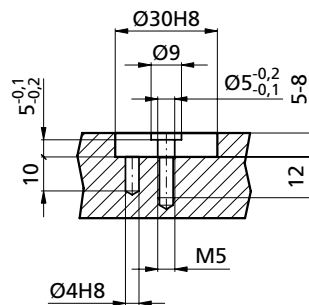
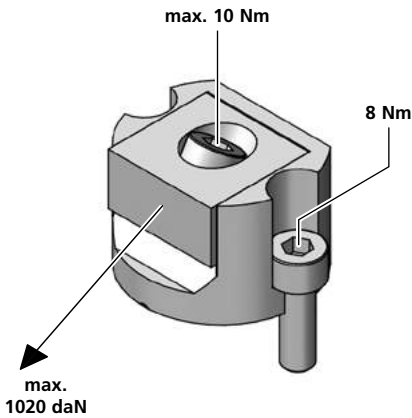
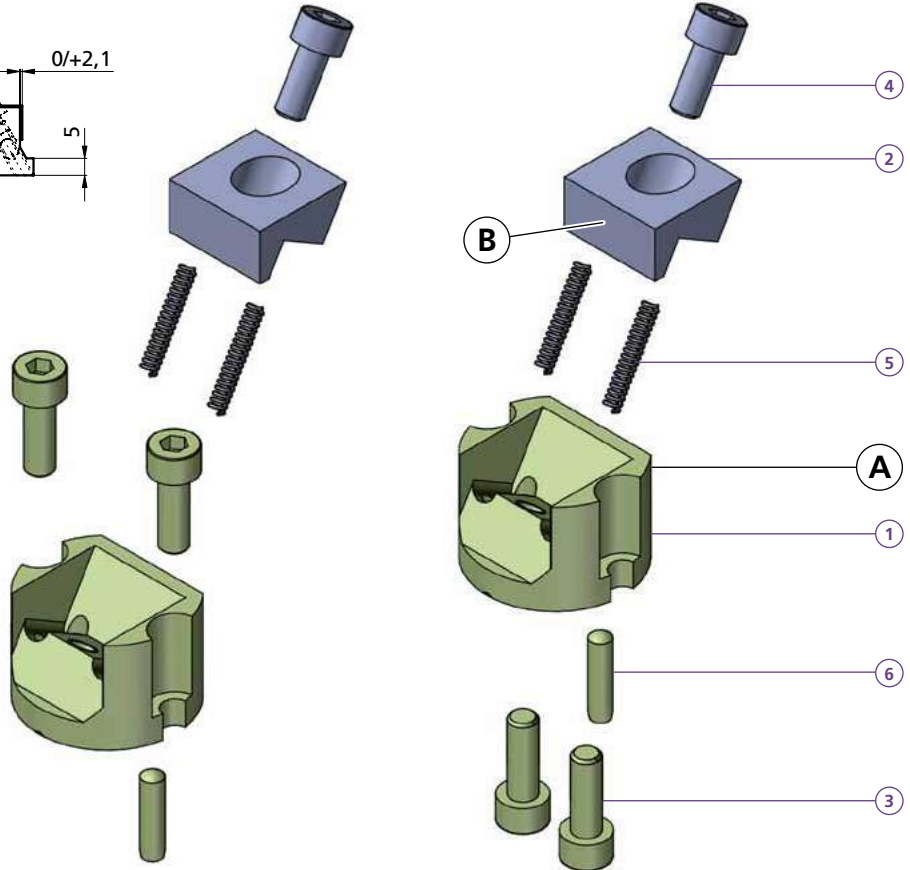

Bestellbeispiel / Ordering example: 1x MR1F30N23-07 & 1x B08

MR1F30N23-07		B07 B08 B09 B09+2 B09+5				
1	1x TF140711					
2	1x					
3	2x M5X16ISO4762					
4	1x M5X12ISO4762					
5	2x FED03018					
6	1x Ø4x14 DIN 6325					
kg	~0,095					
		C	H	L	D	i
		20	20	20	20	20
		10	10	10	10	10
		9,5	9,5	9,5	11,5	14,5
		5,5	5,5	5,5	5,5	5,5
		6	6	6	6	6
		HV700	HV700	*	*	*
		x0,2mm	x0,2mm			
kg		~0,02	~0,02	~0,02	~0,02	~0,02

**B07, B08, B09**

**B09+2, B09+5**

Separat bestellen / Separate order



# MS1F22N40-07

microCLAMP

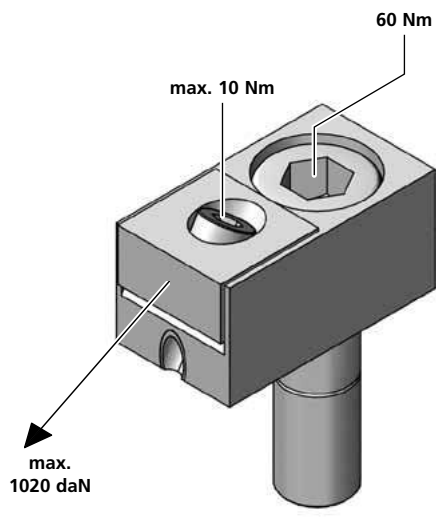
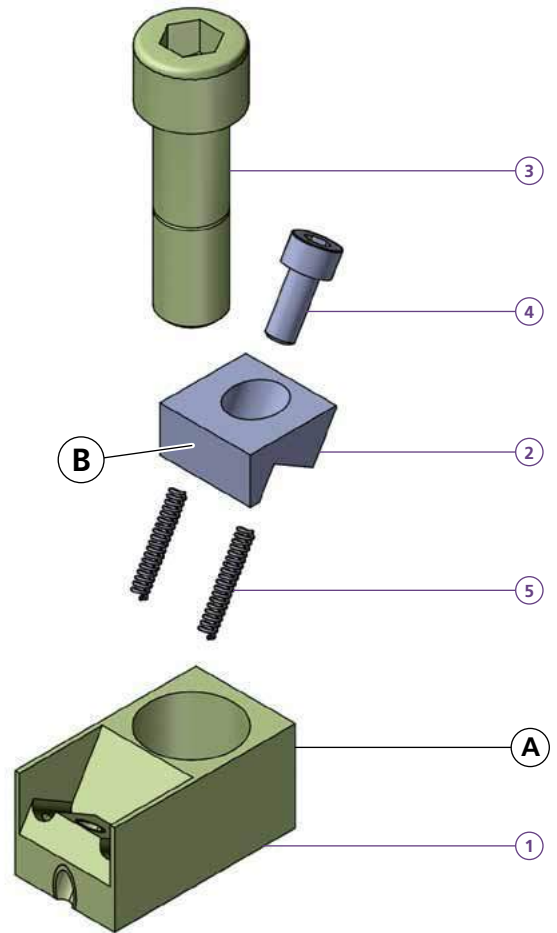
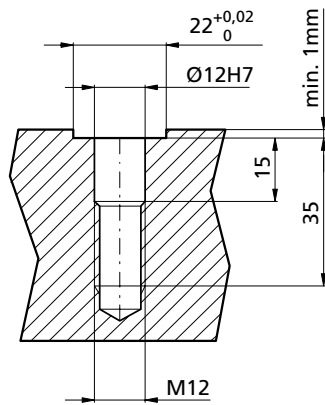
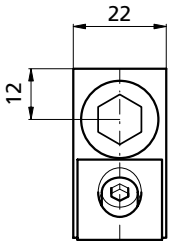
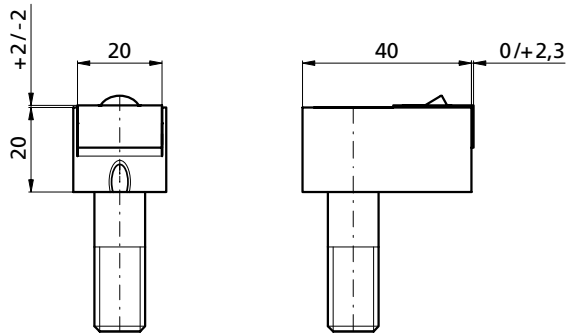

MS1F22N40-07	
1	1x TF140712
2	1x
3	1x TWPAS1240
4	1x M5X12ISO4762
5	2x FED03018
kg	~0,15

	B07	B08	B09	B09+2	B09+5
C	20	20	20	20	20
H	10	10	10	10	10
L	9,5	9,5	9,5	11,5	14,5
D	5,5	5,5	5,5	5,5	5,5
ø	6	6	6	6	6
i	HV700	HV700	*	*	*
	x0,2mm	x0,2mm			
kg	~0,02	~0,02	~0,02	~0,02	~0,02

Bestellbeispiel / Ordering example: 1x MS1F22N40-07 & 1x B08

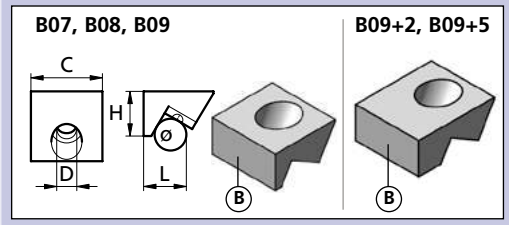

\* = weicher Stahl / soft steel

Separat bestellen / Separate order



# MS1R/F24N22-07

microCLAMP

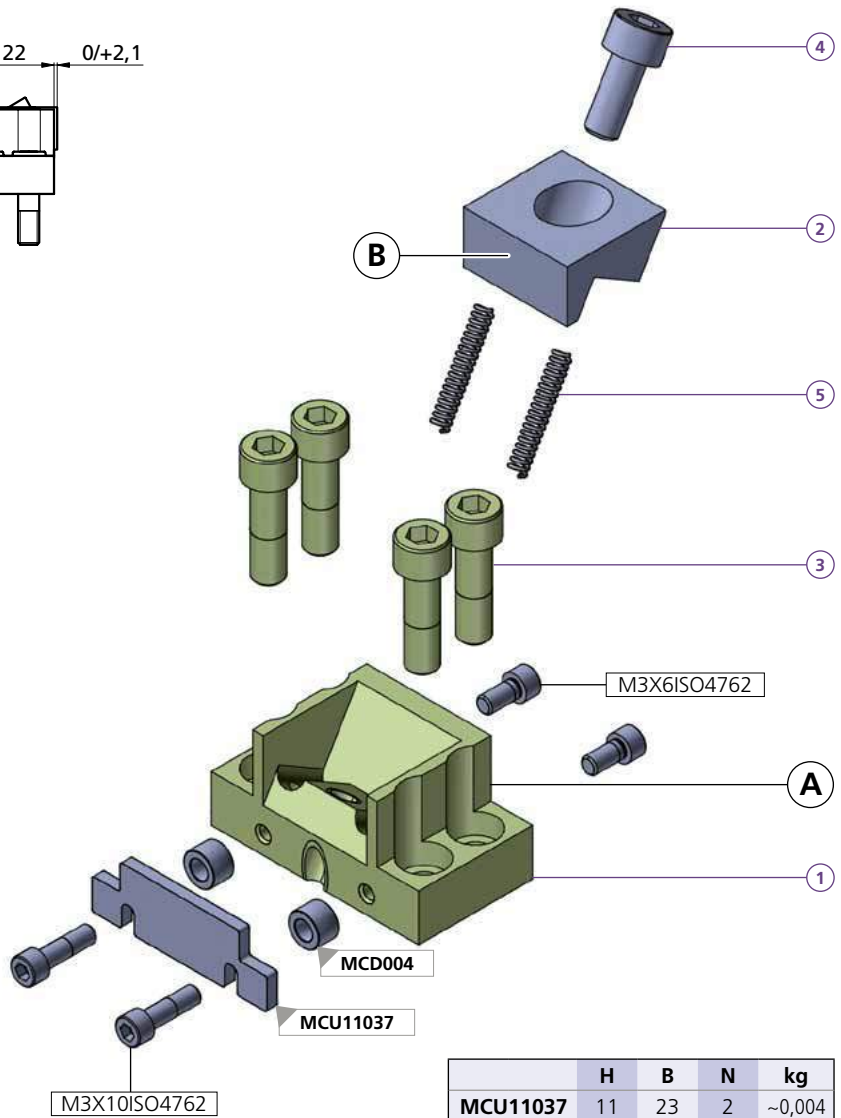
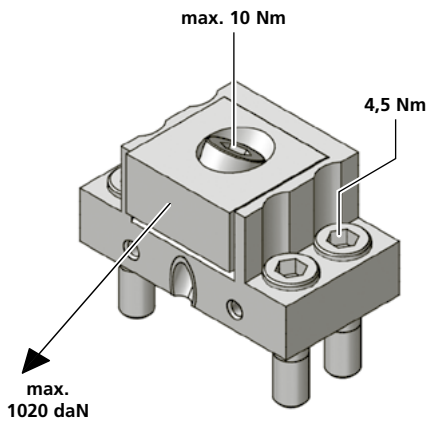
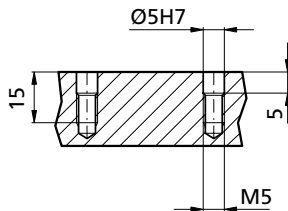
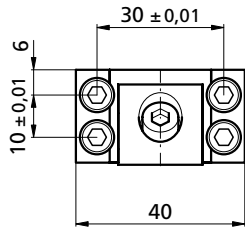
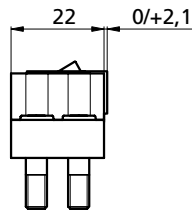
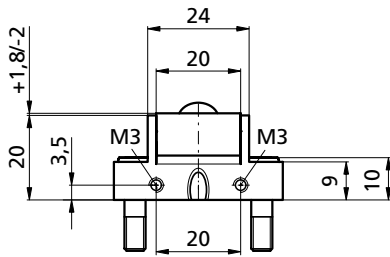

	H	B	N	kg
MCU11037	11	23	2	~0,004
MCU15037	15	23	2	~0,006
MCU18037	18	23	2	~0,008
MCU20037	20	23	2	~0,008
MCU22537	22,5	23	2	~0,008

- 2x M3X10ISO4762
- 2x M3X6ISO4762
- 2x MCD004

**Achtung:** Bei Spannkraften über 400 daN (0,4t) muss das Spannmodul in eine Nut eingelassen werden (Nuttiefe mindestens 1mm)

**Remark:** Using forces higher than 400 daN, clamps must be mounted into a slot (depth minimum 1mm)

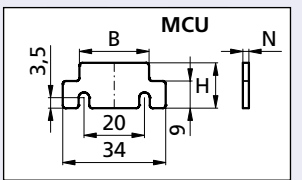
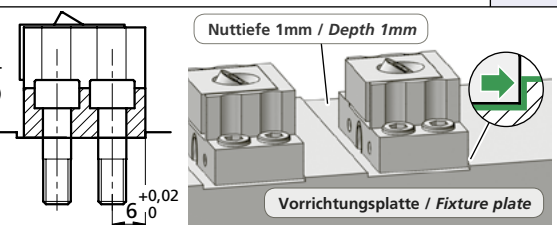

MS1F24N22-07	
1	1x TF140713
MS1R24N22-07	
1	1x TW100172-01
2	1x
3	4x MS50
4	1x M5X12ISO4762
5	2x FED03018
kg	~0,125

Bestellbeispiel / Ordering example: 1x MS1F24N22-07 & 1x B08					
	B07	B08	B09	B09+2	B09+5
C	20	20	20	20	20
H	10	10	10	10	10
L	9,5	9,5	9,5	11,5	14,5
D	5,5	5,5	5,5	5,5	5,5
ø	6	6	6	6	6
i	HV700	HV700	*	*	*
	x0,2mm	x0,2mm			
kg	~0,02	~0,02	~0,02	~0,02	~0,02

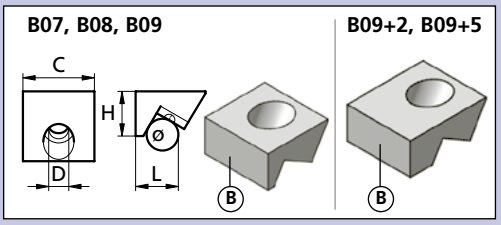

Separat bestellen / Separate order





# MS1R/F25N25-13

microCLAMP

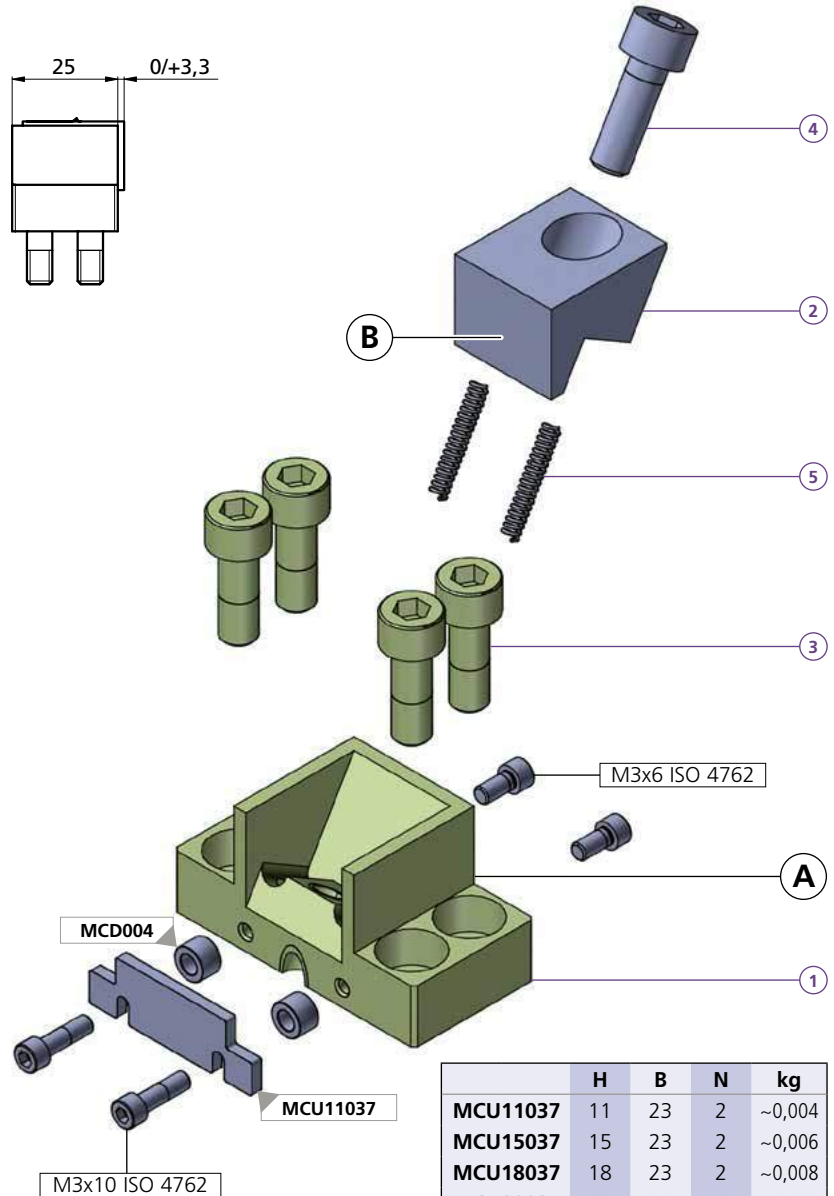
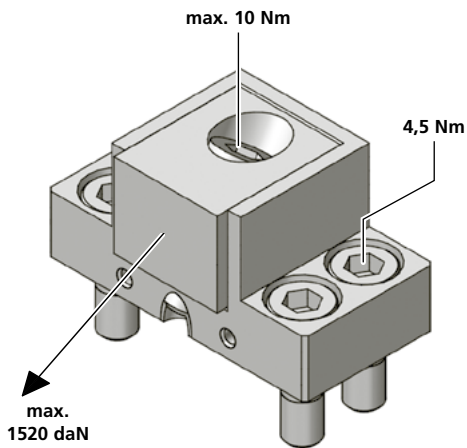
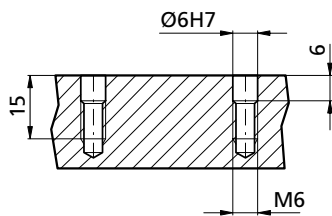
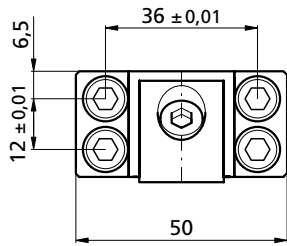
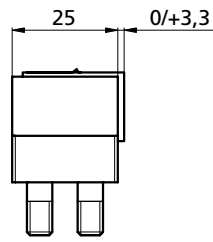
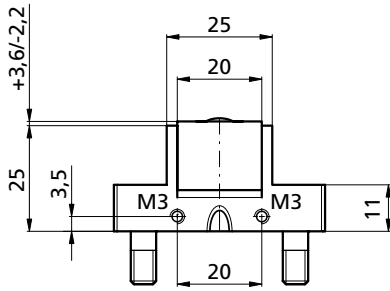

	H	B	N	kg
MCU11037	11	23	2	~0,004
MCU15037	15	23	2	~0,006
MCU18037	18	23	2	~0,008
MCU20037	20	23	2	~0,008
MCU22537	22,5	23	2	~0,008

- 2x M3X10ISO4762
- 2x M3X6ISO4762
- 2x MCD004

**Achtung:** Bei Spannkraften über 400 daN (0,4t) muss das Spannmodul in eine Nut eingelassen werden (Nuttiefe mindestens 1mm)

**Remark:** Using forces higher than 400 daN, clamps must be mounted into a slot (depth minimum 1mm)

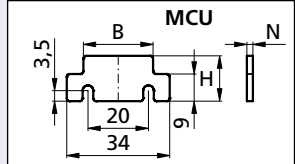
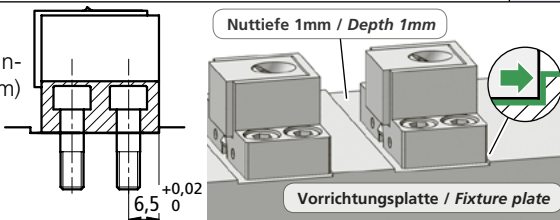

MS1F25N25-13	
1	1x TF140714
MS1R25N25-13	
1	1x TF140715
2	1x
3	4x MS60
4	1x M6X16ISO4762
5	2x FED03018
kg	~0,165

Bestellbeispiel / Ordering example: 1x MS1F25N25-13 & 1x B14

	B13	B14	B15	B16
C	20	20	20	20
H	16	16	16	16
L	13,8	13,8	13,8	19
D	6,5	6,5	6,5	6,5
ø	10	10	10	10
i	HV700	HV700	*	*
	x0,2mm	x0,2mm		
kg	~0,05	~0,05	~0,05	~0,06

\* = weicher Stahl / soft steel

Separat bestellen / Separate order



# MS1R/F35N14-01

# MS1F35N22-01

microCLAMP

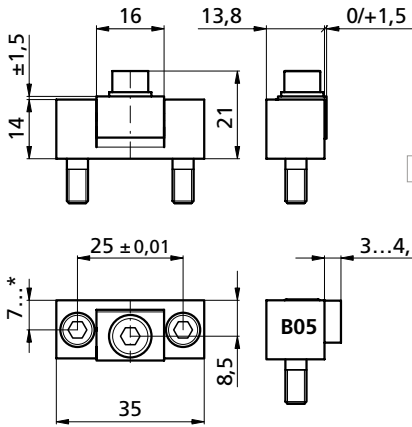

MS1F35N14-01

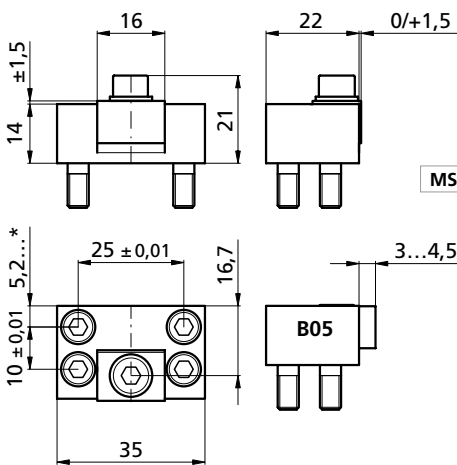
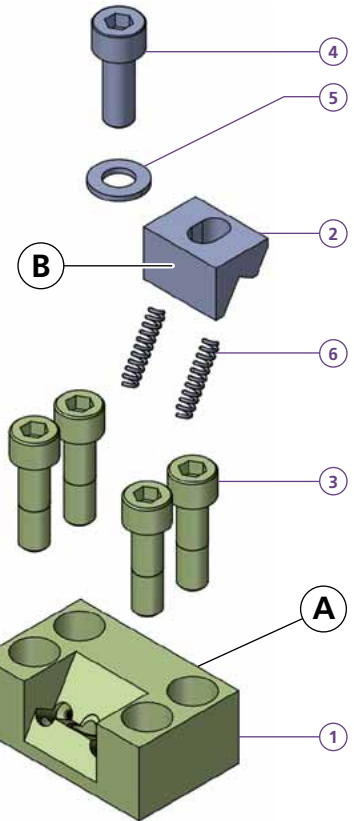
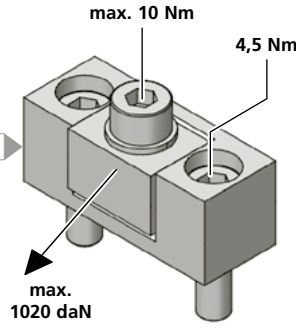

MS1F35N22-01

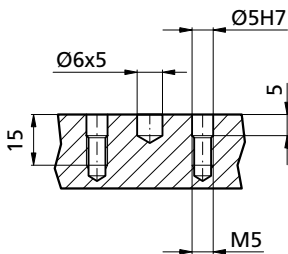
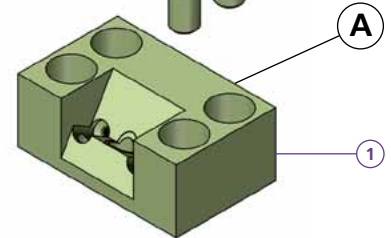
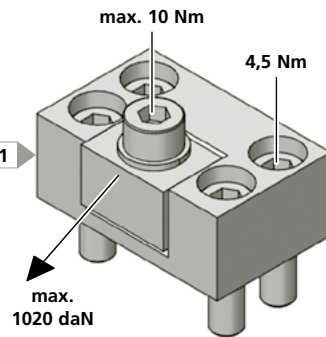

**Beim Einsatz der Backe B05(R) Jaw B05(R) in use**  
 Nachbearbeitung am Modul, falls If a stroke of 1,1mm to 1,5mm der gesamte Backenhub (1,1mm bis is required the module must be 1,5mm) benötigt wird. machined according to this sketch.

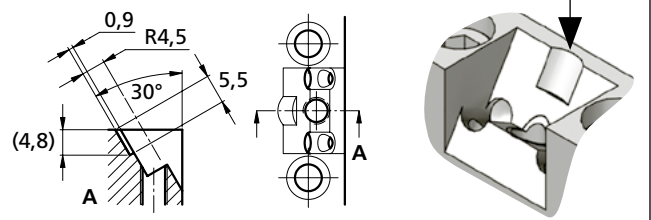

**Achtung:** Bei Spannkraften über 400 daN (0,4t) muss das Spannmodul in eine Nut eingelassen werden (Nuttiefe mindestens 1mm)

**Remark:** Using forces higher than 400 daN, clamps must be mounted into a slot (depth minimum 1mm)

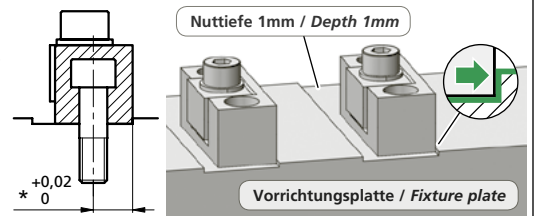

<b>MS1F35N14-01</b>	<b>A</b>
1x TF140718	
<b>MS1R35N14-01</b>	<b>B</b>
1x TK190150	
1x	
2x MS50	
1x M5X14ISO4762	
1x 5x10x1DIN125A	
2x FED02813	
kg ~0,05	
<b>MS1F35N22-01</b>	<b>A</b>
1x TF140719	
4x MS50	
kg ~0,08	

Bestellbeispiel / Ordering example: 1x MS1F35N14-01 & 1x B02

	B01	B02	B03	B04	B05	B05R
C	16	16	16	16	16	16
H	10	10	10	10	10	10
L	8	8	11	8	10	10
D	5,5	5,5	5,5	5,5	5,2	5,2
ø	4	4	4	4	4	4
i	HV700	HV700	*	Messing	HV700	HV700
	x0,2mm	x0,2mm		Laiton	x0,2mm	x0,2mm
kg	~0,01	~0,01	~0,014	~0,012	~0,014	~0,014

M5X10DIN6912



# MS2X35N23-01

microCLAMP

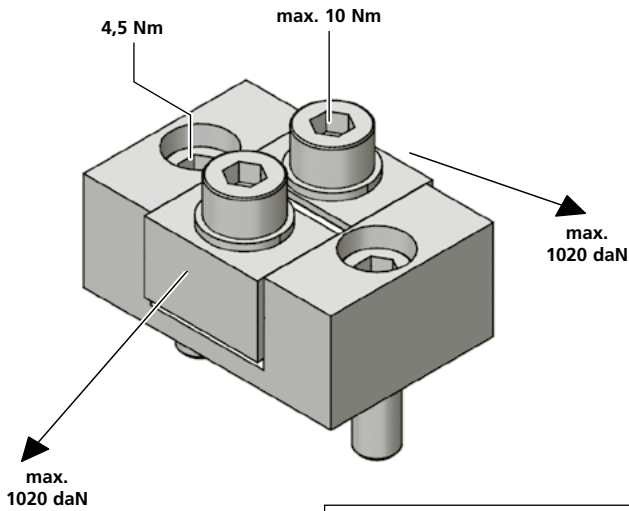
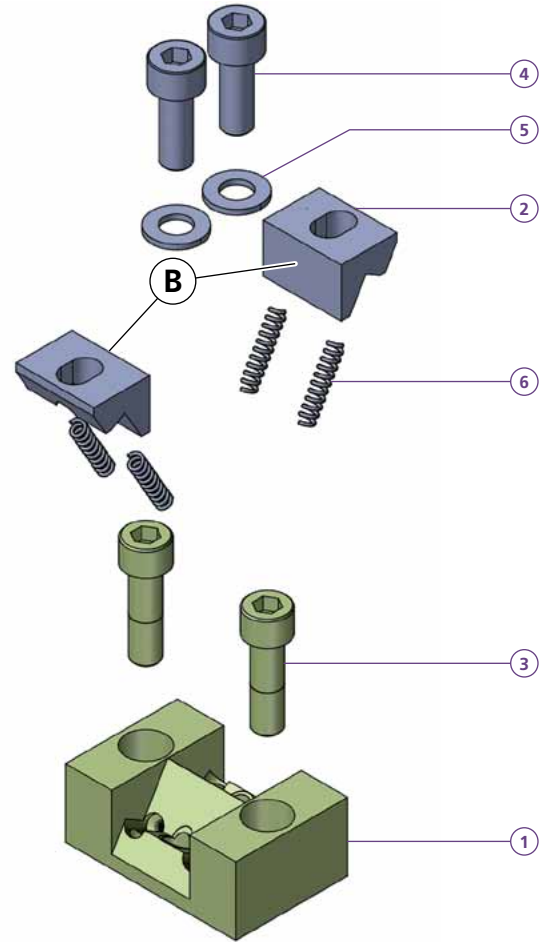
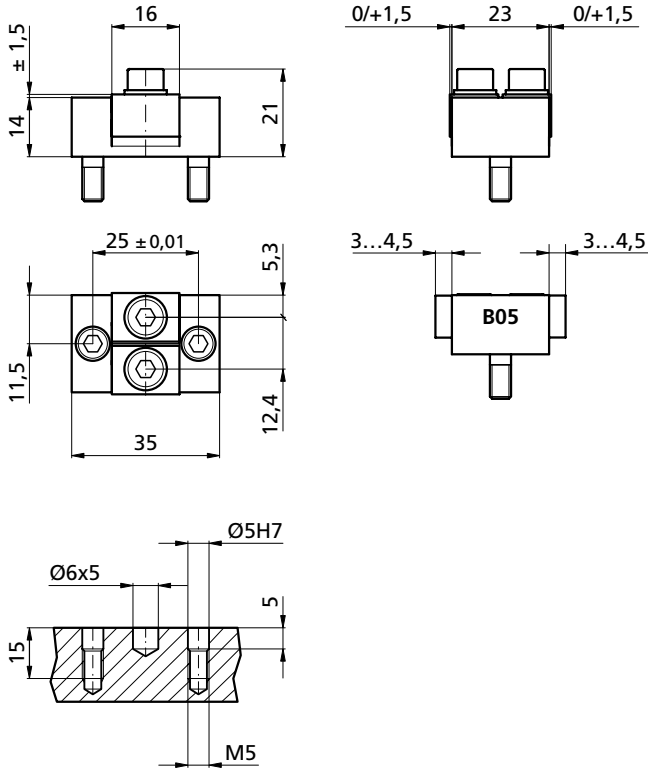

**Beim Einsatz der Backe B05(R) Jaw B05(R) in use**  
 Nachbearbeitung am Modul, falls If a stroke of 1,1mm to 1,5mm  
 der gesamte Backenhub (1,1mm bis is required the module must be  
 1,5mm) benötigt wird. machined according to this sketch.

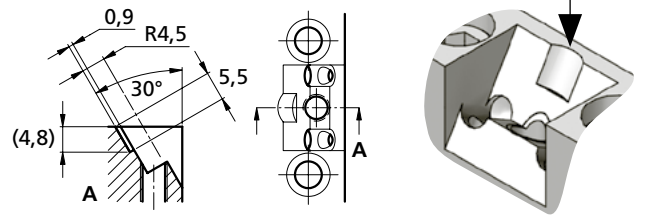

**Achtung:** Bei Spannkraften über 400 daN (0,4t) muss das Spannmodul in eine Nut eingelassen werden (Nuttiefe mindestens 1mm)

**Remark:** Using forces higher than 400 daN, clamps must be mounted into a slot (depth minimum 1mm)

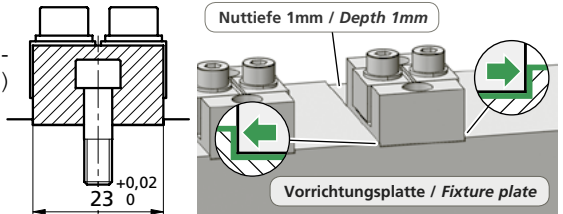

**Bestellbeispiel / Ordering example: 1x MS2X35N23-01 & 2x B02**

MS2X35N23-01		B01	B02	B03	B04	B05	B05R
1	1x TF140720						
2	2x						
3	2x MS50						
4	2x M5X14ISO4762						
5	2x 5x10x1DIN125A						
6	4x FED02813						
kg	~0,085	kg	~0,01	~0,01	~0,014	~0,012	~0,014

	B01	B02	B03	B04	B05	B05R
C	16	16	16	16	16	16
H	10	10	10	10	10	10
L	8	8	11	8	10	10
D	5,5	5,5	5,5	5,5	5,2	5,2
ø	4	4	4	4	4	4
i	HV700 x0,2mm	HV700 x0,2mm	*	Messing Laiton	HV700 x0,2mm	HV700 x0,2mm

**Detail View B:** Shows dimensions C, H, L, D, and a chamfered edge with a 30-degree angle.

**Detail View A:** Shows the chamfered edge profile.

\* = weicher Stahl / soft steel

Separat bestellen / Separate order





# MS2F60N14-01

microCLAMP

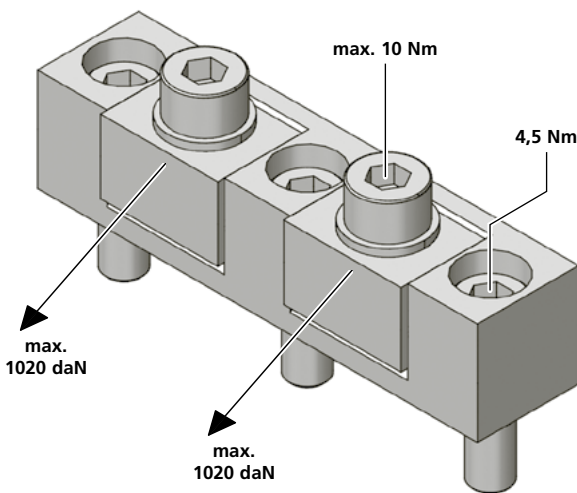
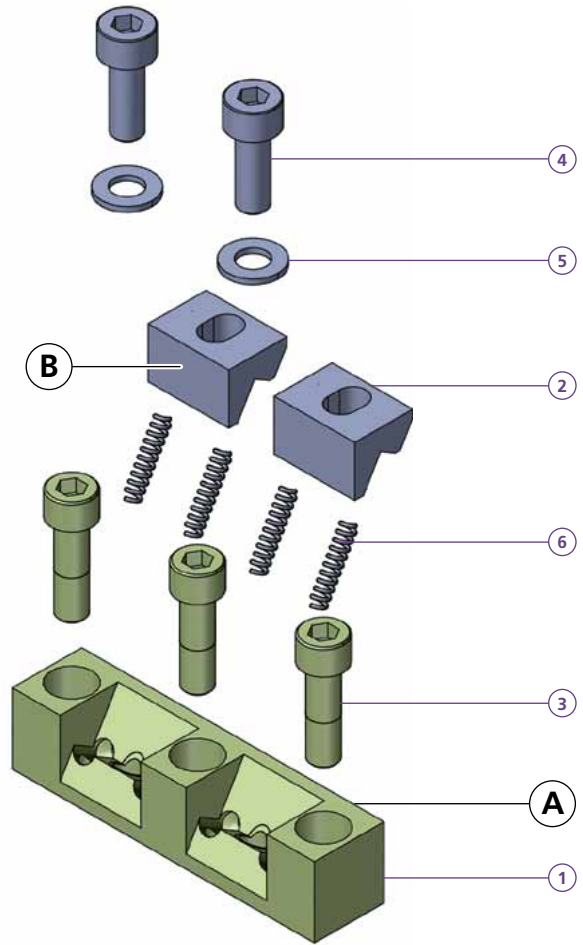
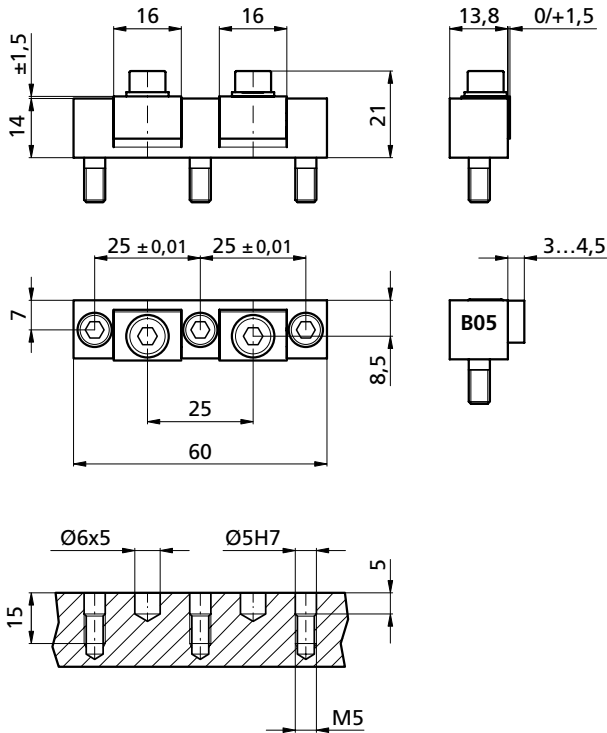

**Beim Einsatz der Backe B05(R) Jaw B05(R) in use**  
 Nachbearbeitung am Modul, falls *If a stroke of 1,1mm to 1,5mm*  
 der gesamte Backenhub (1,1mm bis *is required the module must be*  
 1,5mm) benötigt wird. *machined according to this sketch.*

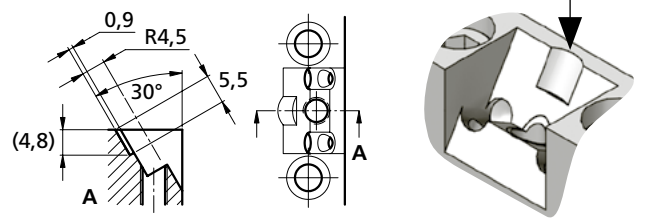

**Achtung:** Bei Spannkraften über 400 daN (0,4t) muss das Spannmodul in eine Nut eingelassen werden (Nuttiefe mindestens 1mm)  
**Remark:** Using forces higher than 400 daN, clamps must be mounted into a slot (depth minimum 1mm)

Bestellbeispiel / Ordering example: 1x MS2F60N14-01 & 2x B02

MS2F60N14-01		MSX10DIN6912					
		B01	B02	B03	B04	B05	B05R
1	1x TF140721						
2	2x						
3	3x MS50						
4	2x M5X14ISO4762						
5	2x 5x10x1DIN125A						
6	4x FED02813						
		C	16	16	16	16	16
		H	10	10	10	10	10
		L	8	8	11	8	10
		D	5,5	5,5	5,5	5,5	5,2
		ø	4	4	4	4	4
		i	HV700	HV700	*	Messing	HV700
			x0,2mm	x0,2mm		Laiton	x0,2mm
kg	~0,09	kg	~0,01	~0,01	~0,014	~0,012	~0,014

**B01, B02, B03, B04**

**B05 B05R**



# MS3F85N14-01

microCLAMP

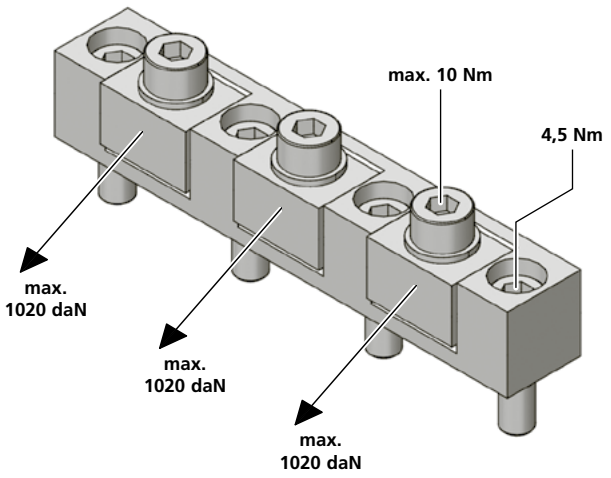
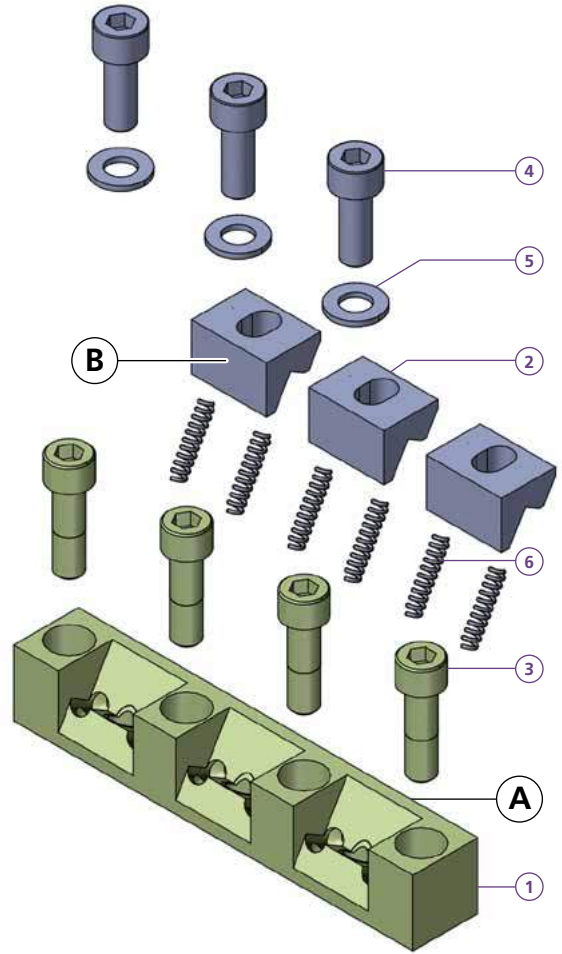
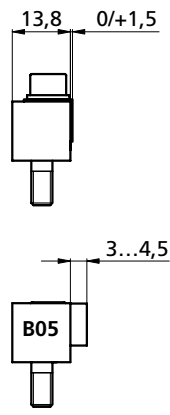
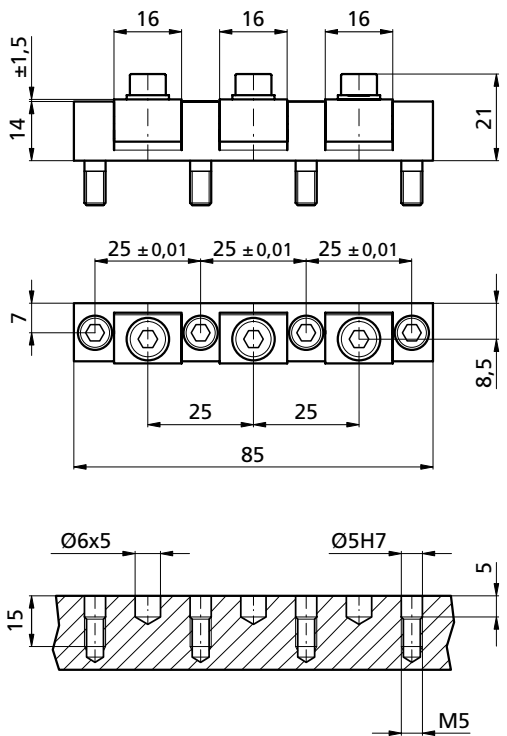

**Beim Einsatz der Backe B05(R) Jaw B05(R) in use**  
 Nachbearbeitung am Modul, falls If a stroke of 1,1mm to 1,5mm  
 der gesamte Backenhub (1,1mm bis is required the module must be  
 1,5mm) benötigt wird. machined according to this sketch.

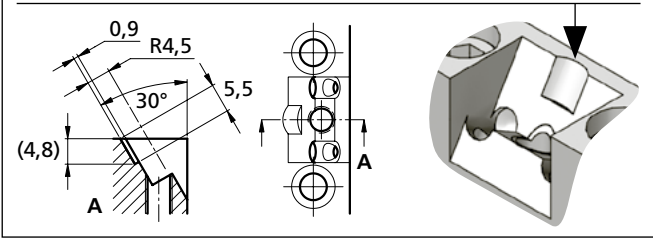

**Achtung:** Bei Spannkraften über 400 daN (0,4t) muss das Spannmodul in eine Nut eingelassen werden (Nuttiefe mindestens 1mm)  
**Remark:** Using forces higher than 400 daN, clamps must be mounted into a slot (depth minimum 1mm)

Bestellbeispiel / Ordering example: 1x MS3F85N14-01 & 3x B02

MS3F85N14-01	B01	B02	B03	B04	B05	B05R
① 1x TH160579						
② 3x						
③ 4x MS50						
④ 3x M5X14ISO4762						
⑤ 3x 5x10x1DIN125A						
⑥ 6x FED02813						
kg ~0,125	kg ~0,01	kg ~0,01	kg ~0,014	kg ~0,012	kg ~0,014	kg ~0,014

	C	H	L	D
B01, B02, B03, B04	16	10	8	5,5
B05	16	10	10	5,2
B05R	16	10	10	5,2

M5X10DIN6912

\* = weicher Stahl / soft steel

Separat bestellen / Separate order



# VS1R/F19N35-20

microCLAMP

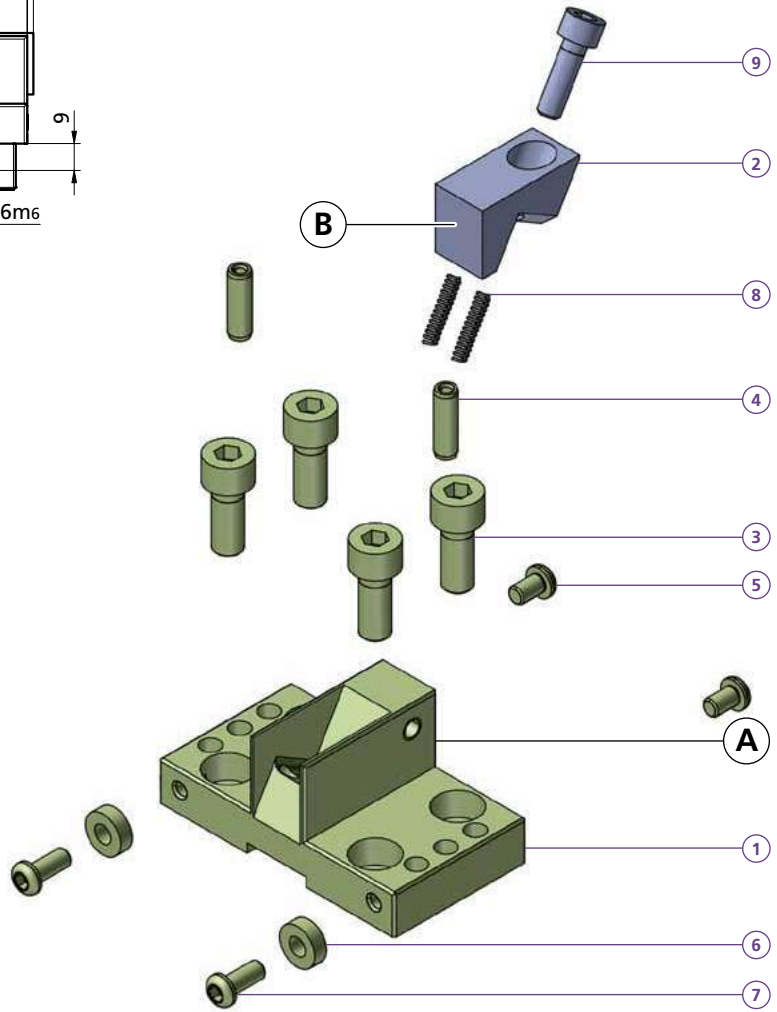
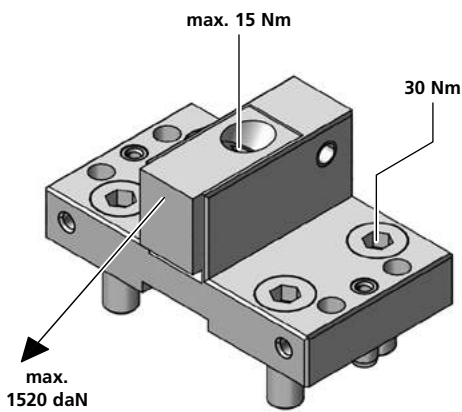
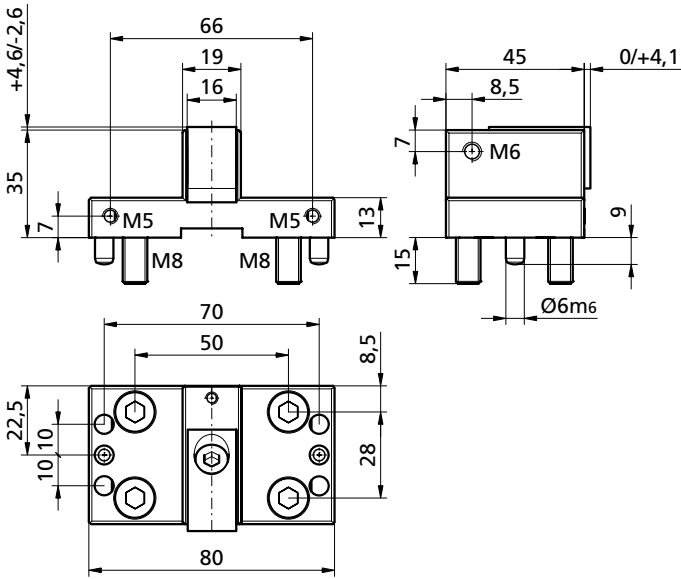

	<b>A</b>
<b>VS1F19N35-20</b>	
1	1x TF150029
<b>VS1R19N35-20</b>	
1	1x TF140723
2	1x
3	4x M8X20ISO4762
4	2x CCBO0802
5	2x M5X8ISO7380
6	2x CCD004
7	2x M5X12ISO7380
8	2x FED0418
9	1x M6X20ISO4762
kg	~0,505

**B** Bestellbeispiel / Ordering example: 1x VS1R19N35-20 & 1x B21

	<b>B20</b>	<b>B21</b>	<b>B22</b>
<b>C</b>	16	16	16
<b>H</b>	20	20	20
<b>L</b>	19	19	19
<b>D</b>	6,5	6,5	6,5
<b>ø</b>	12	12	12
<b>i</b>	HV700 x0,2mm	HV700 x0,2mm	*
kg	~0,011	~0,011	~0,011

**B20, B21, B22**

Separat bestellen / Separate order





# VS1R26N35-26

microCLAMP

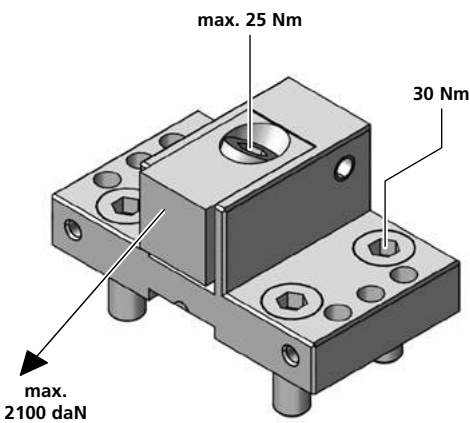
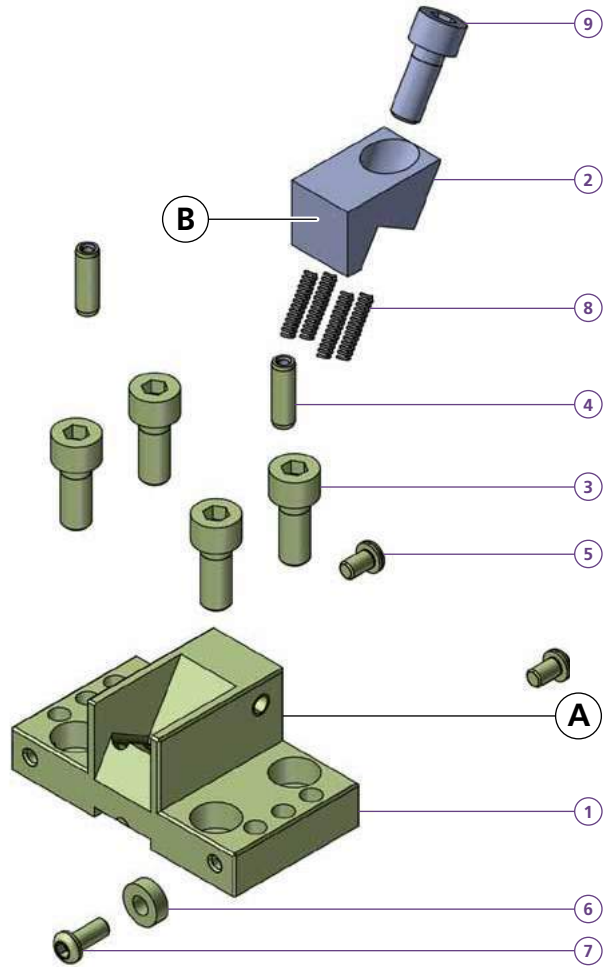
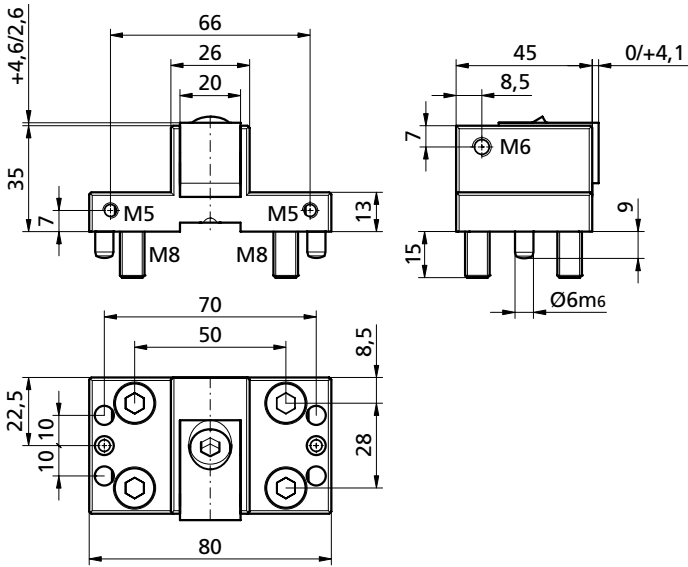

VS1R26N35-26	
1	1x TF140725
2	1x
3	4x M8X20ISO4762
4	2x CCBO0802
5	2x M5X8ISO7380
6	2x CCD004
7	2x M5X12ISO7380
8	4x FED0418
9	1x M8X20ISO4762
kg	~0,55

Bestellbeispiel / Ordering example: 1x VS1R26N35-26 & 1x B27

	B26	B27	B28
C	20	20	20
H	20	20	20
L	19	19	19
D	9	9	9
ø	12	12	12
i	HV700	HV700	*
	x0,2mm	x0,2mm	
kg	~0,064	~0,064	~0,064

**B26, B27, B28**

\* = weicher Stahl / soft steel

Separat bestellen / Separate order



# VS1R38N50-60

microCLAMP

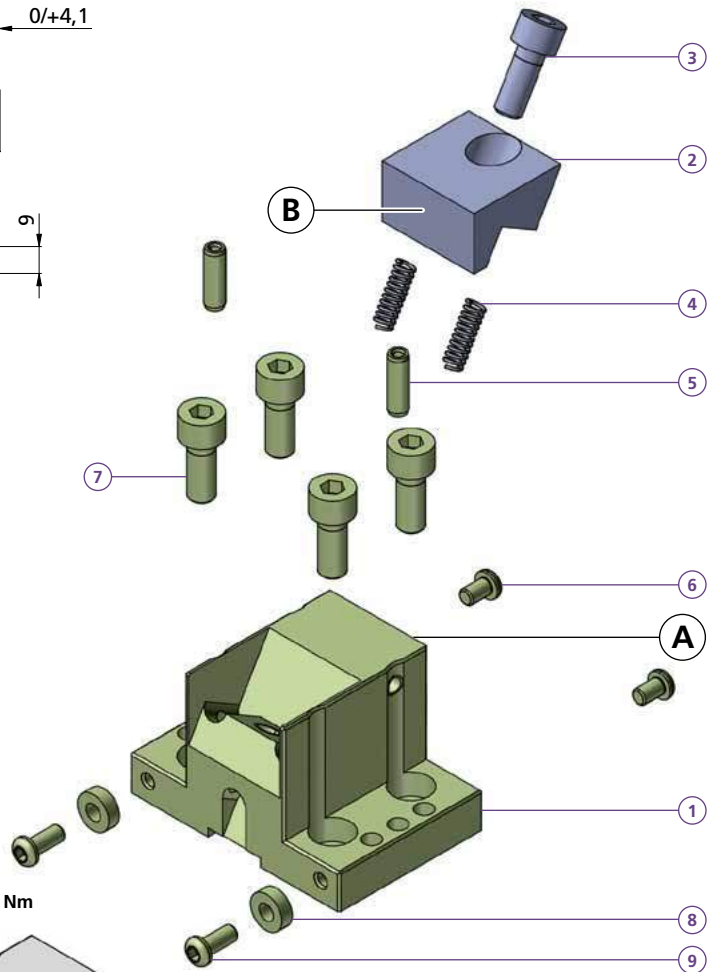
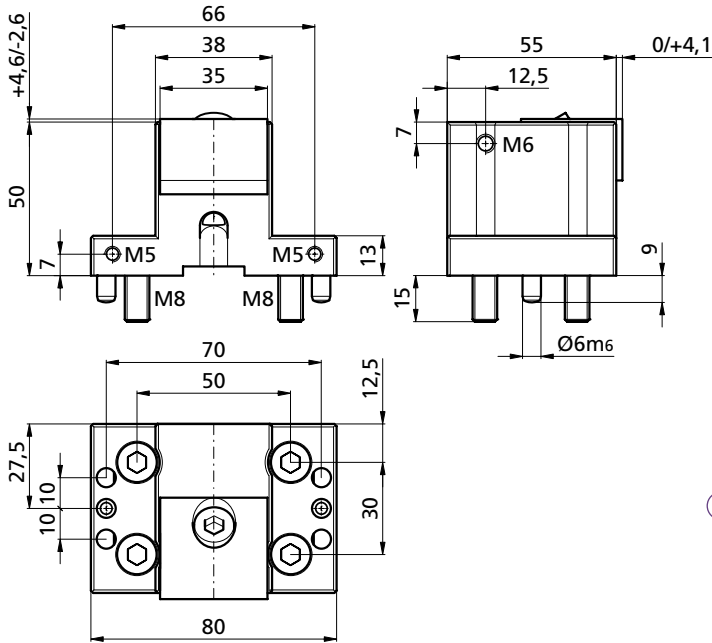

**VS1R38N50-60**

1	1x	TF140726
2	1x	
3	1x	M8X20ISO4762
4	2x	FED0618
5	2x	CCBO0802
6	2x	M5X8ISO7380
7	4x	M8X20ISO4762
8	2x	CCD004
9	2x	M5X12ISO7380
kg		~1,01

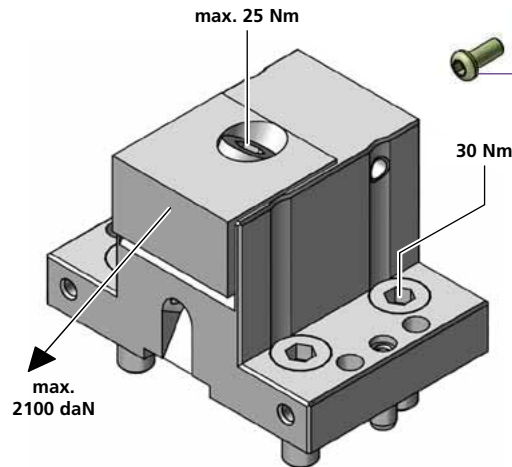

Bestellbeispiel / Ordering example: 1x VS1R38N50-60 & 1x B61

	B58	B60	B61	B62	B62HM	B65	B66	B67	B68	B69	B77	B79F	B79R
C	35	35	35	35	35	35	35	35	35	35	35	35	35
H	20	20	20	20	20	20	20	20	20	25	20	20	20
L	26	19	19	19	19	19	19	24	26	22	22	25	25
D	9	9	9	9	9	9	9	9	9	9	9	9	9
ø	12	12	12	12	12	12	12	12	12	12	12	12	12
i	ALU	56HRC	56HRC	*	HM	HV700 x0,2mm	HV700 x0,2mm	HV700 x0,2mm	*	*	56HRC	HV700 x0,2mm	HV700 x0,2mm
kg	~0,07	~0,12	~0,12	~0,12	~0,12	~0,12	~0,12	~0,14	~0,15	~0,15	~0,12	~0,18	~0,18

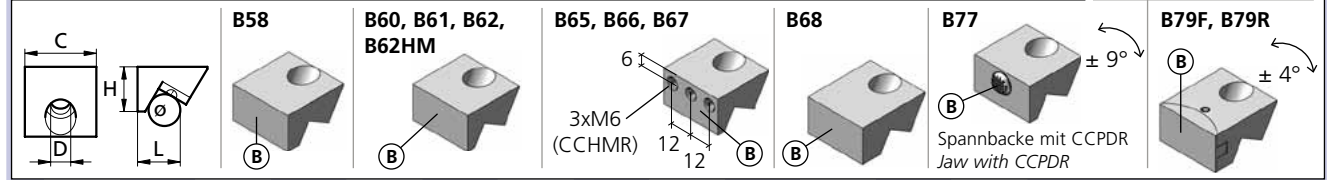
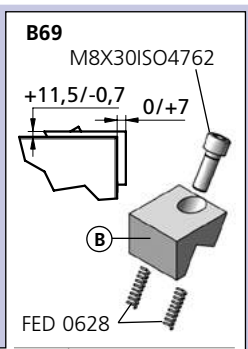



# VS1R/F41N30-60

microCLAMP

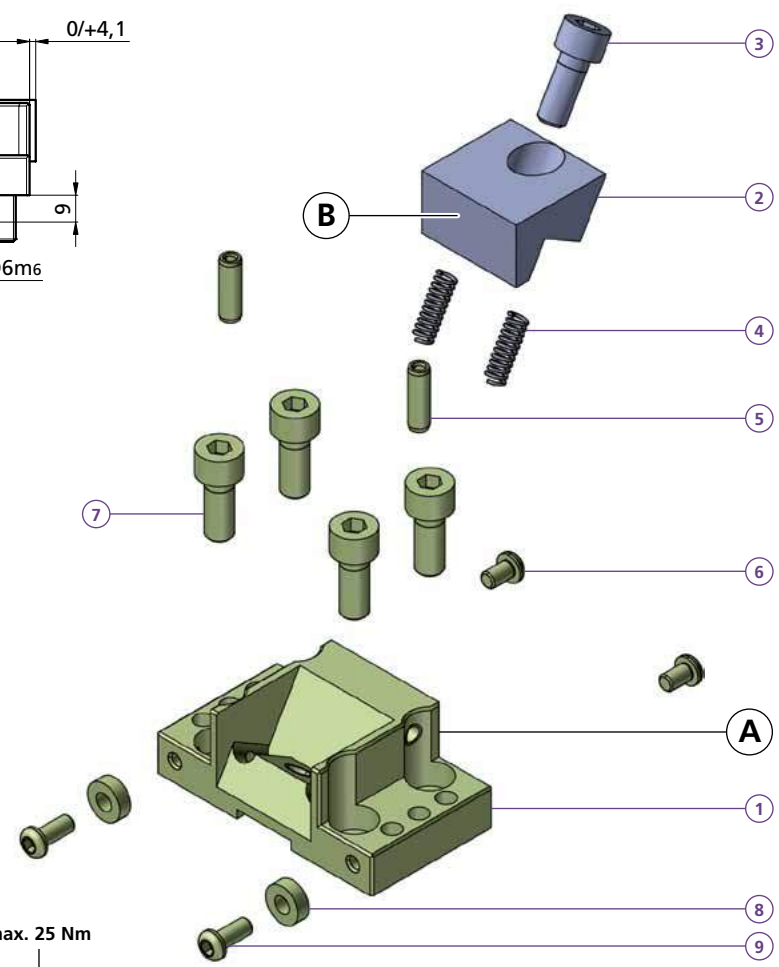
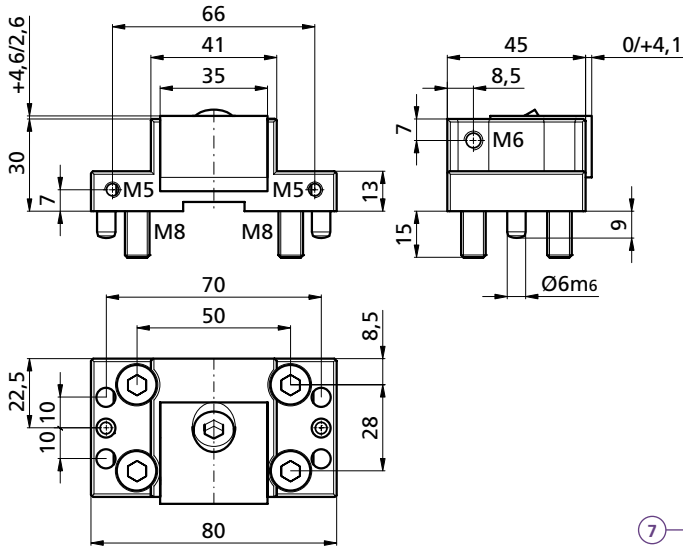

- VS1F41N30-60**
- 1x TF140729
- VS1R41N30-60**
- 1x TF140730
- 1x
- 1x M8X20ISO4762
- 2x FED0618
- 2x CCBO0802
- 2x M5X8ISO7380
- 4x M8X20ISO4762
- 2x CCD004
- 2x M5X12ISO7380
- kg ~0,58

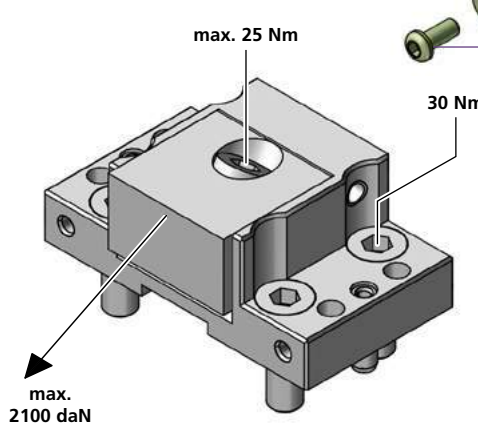

Bestellbeispiel / Ordering example: 1x VS1R41N30-60 & 1x B61

	B58	B60	B61	B62	B62HM	B65	B66	B67	B68	B77	B79F	B79R
C	35	35	35	35	35	35	35	35	35	35	35	35
H	20	20	20	20	20	20	20	20	20	20	20	20
L	26	19	19	19	19	19	19	24	26	22	25	25
D	9	9	9	9	9	9	9	9	9	9	9	9
ø	12	12	12	12	12	12	12	12	12	12	12	12
i	ALU	56HRC	56HRC	*	HM	HV700	HV700	HV700	*	56HRC	HV700	HV700
		x0,2mm	x0,2mm			x0,2mm	x0,2mm	x0,2mm			x0,2mm	x0,2mm
kg	~0,07	~0,12	~0,12	~0,12	~0,12	~0,12	~0,12	~0,14	~0,15	~0,12	~0,18	~0,18

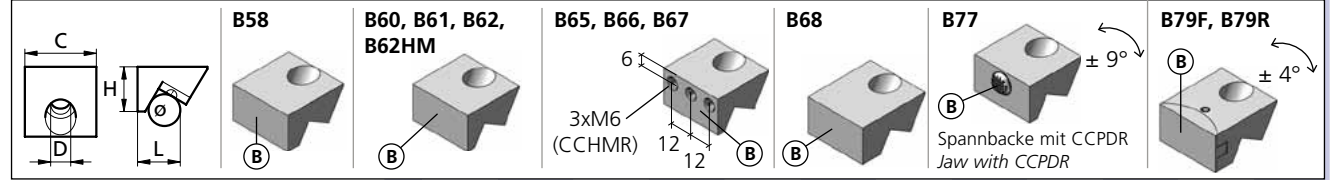

\* = weicher Stahl / soft steel      HM = Hartmetallbeschichtet / Carbide coated      ALU = ENAW-7022

Separat bestellen / Separate order





# VS1R/F80N30-36

# VS1R80N50-36

microCLAMP

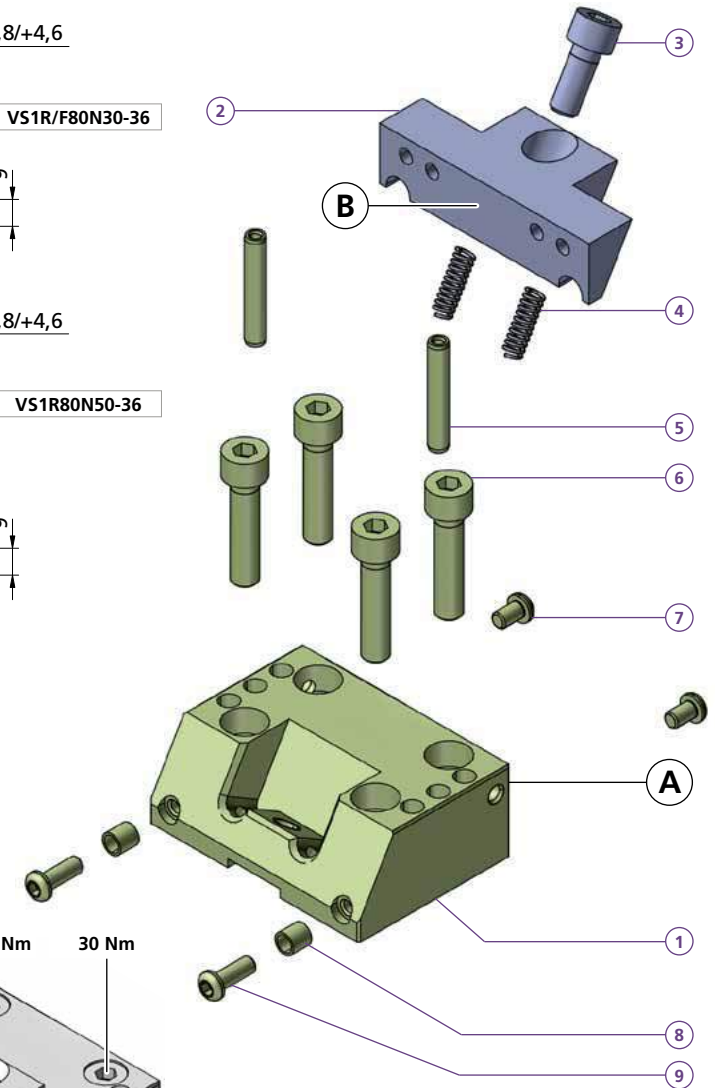
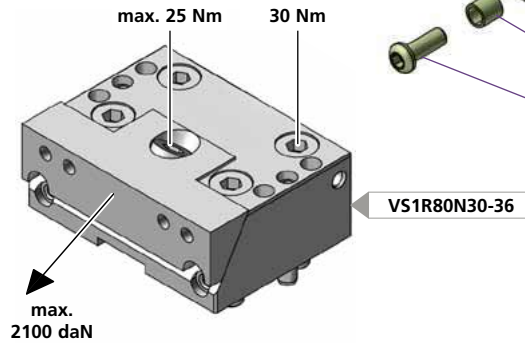
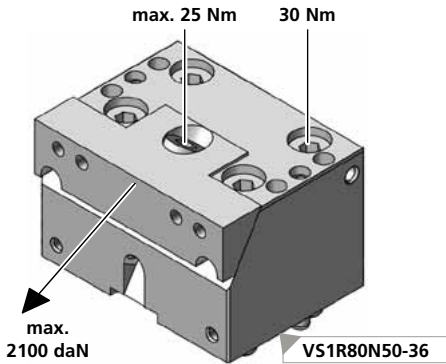
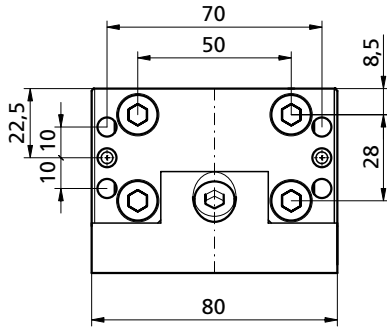
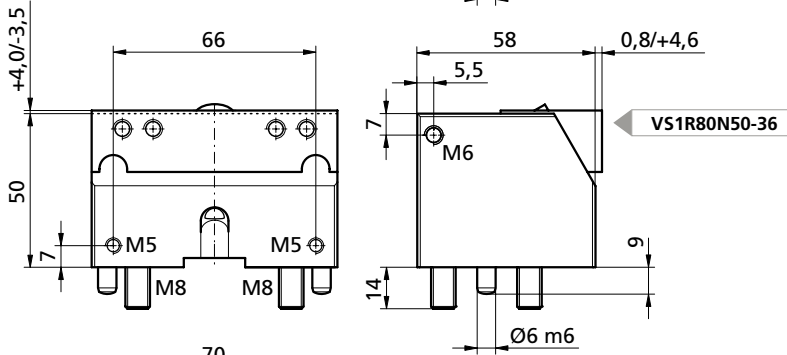
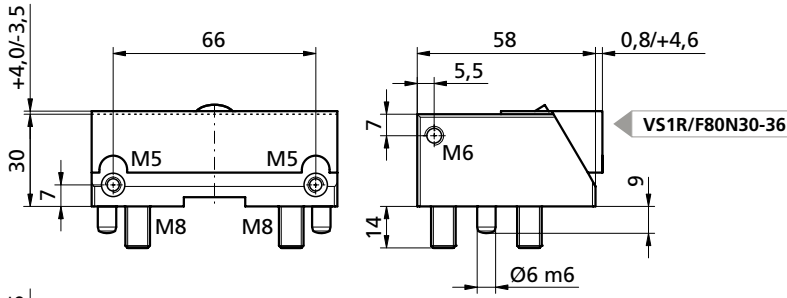

<b>VS1F80N30-36</b>	<b>VS1R80N30-36</b>	<b>VS1R80N50-36</b>
1x TF140733	1x TF140734	1x TF140742
1x M8X20ISO4762	1x M8X35ISO4762	2x CCBO0803
4x FED0618	2x M5X8ISO4762	4x M8X55ISO4762
2x CCBO0801	2x CCD007	2x CCD005
4x M8X35ISO4762	2x M5X16ISO7380	2x M5X12ISO7380
kg ~1,2	kg ~1,9	

Bestellbeispiel / Ordering example: 1x VS1R80N30-36 & 1x B37

	B36	B37	B38
C	80	80	80
H	20	20	20
L	19	19	19
D	9	9	9
e	12	12	12
i	HV700	HV700	*
	x0,2mm	x0,2mm	
kg	~0,18	~0,18	~0,18

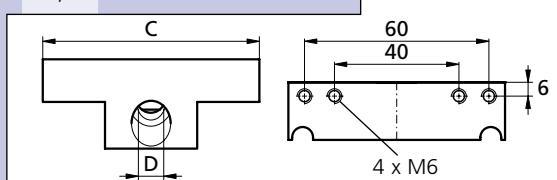
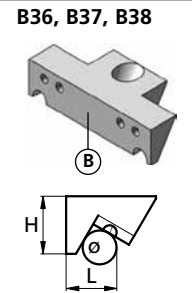

Separat bestellen / Separate order



# VS1R/F80N30-60

microCLAMP

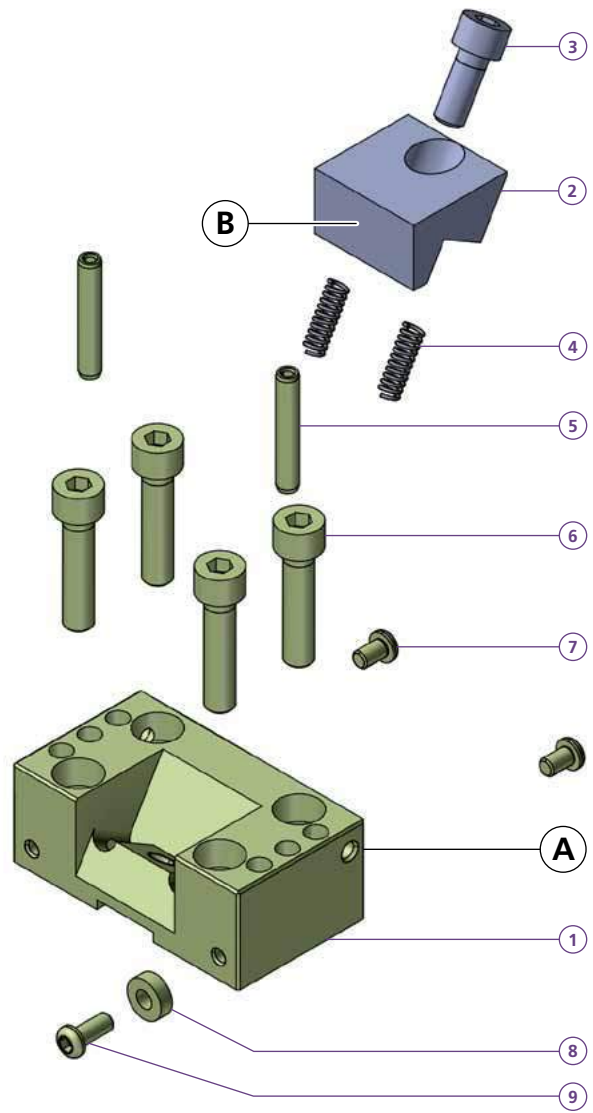
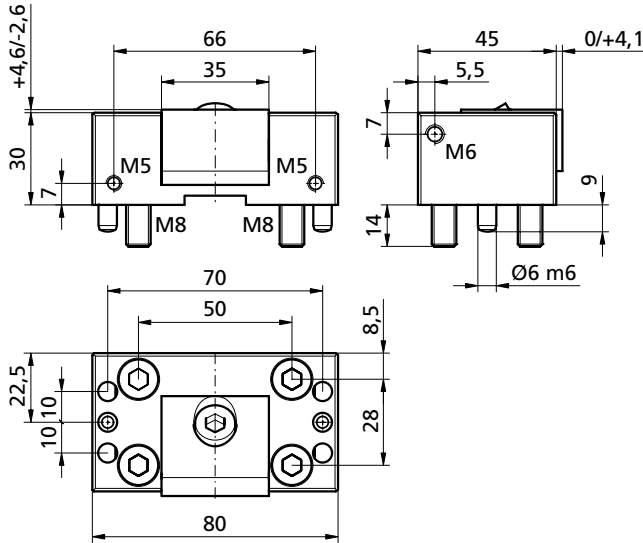

- VS1F80N30-60**
- 1 1x TF140735
- VS1R80N30-60**
- 1 1x TF140736
  - 2 1x
  - 3 1x M8X20ISO4762
  - 4 2x FED0618
  - 5 2x CCBO0801
  - 6 4x M8X35ISO4762
  - 7 2x M5X8ISO7380
  - 8 2x CCD004
  - 9 2x M5X12ISO7380
- kg ~0,74

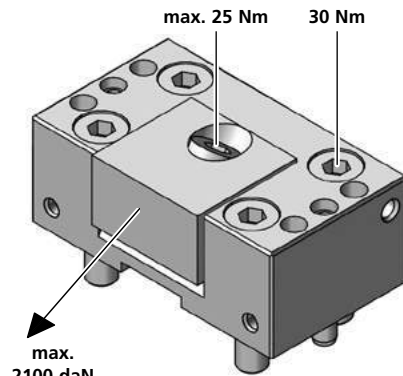

Bestellbeispiel / Ordering example: 1x VS1F80N30-60 & 1x B61

	B58	B60	B61	B62	B62HM	B65	B66	B67	B68	B77	B79F	B79R
C	35	35	35	35	35	35	35	35	35	35	35	35
H	20	20	20	20	20	20	20	20	20	20	20	20
L	26	19	19	19	19	19	19	24	26	22	25	25
D	9	9	9	9	9	9	9	9	9	9	9	9
o	12	12	12	12	12	12	12	12	12	12	12	12
i	ALU	56HRC	56HRC	*	HM	HV700 x0,2mm	HV700 x0,2mm	HV700 x0,2mm	*	56HRC	HV700 x0,2mm	HV700 x0,2mm
kg	~0,07	~0,12	~0,12	~0,12	~0,12	~0,12	~0,12	~0,14	~0,15	~0,12	~0,18	~0,18

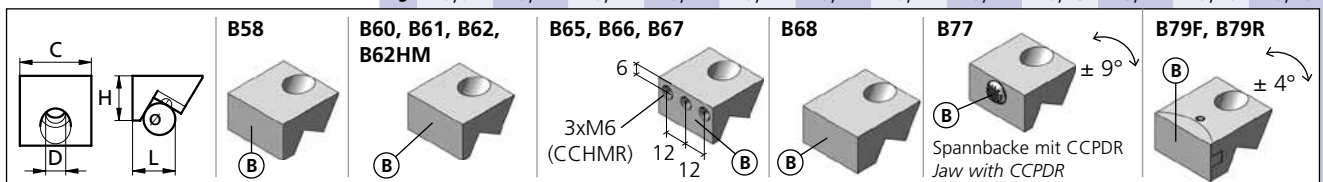

\* = weicher Stahl / soft steel

HM = Hartmetallbeschichtet / Carbide coated

ALU = ENAW-7022



# VS1R80N50-60

microCLAMP

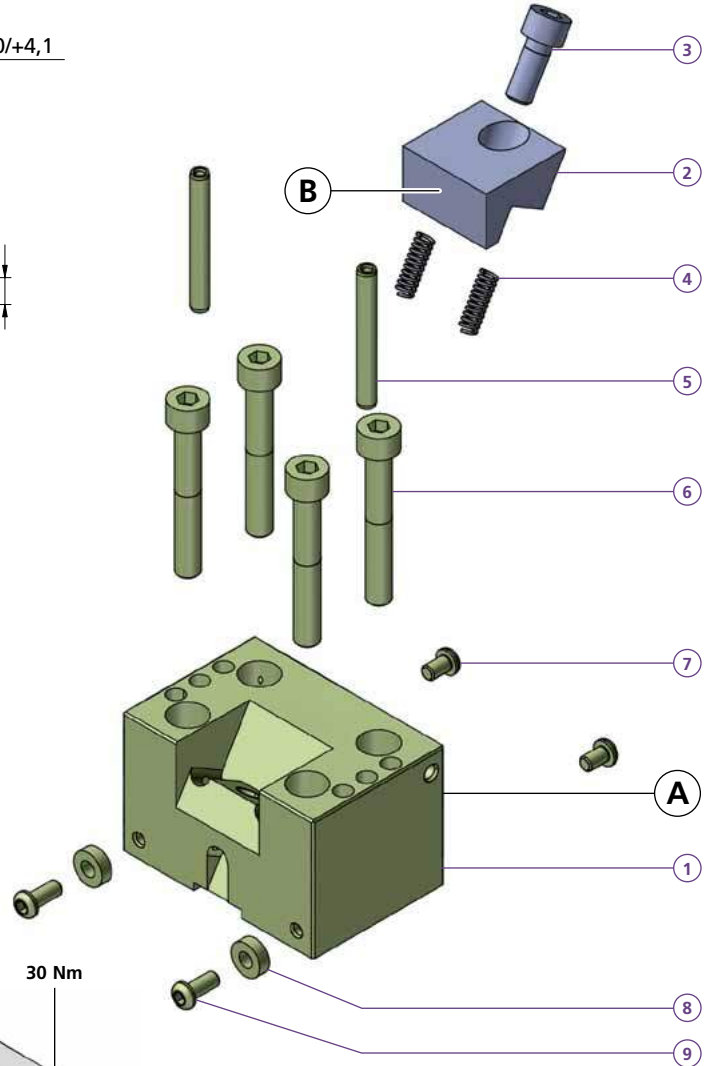
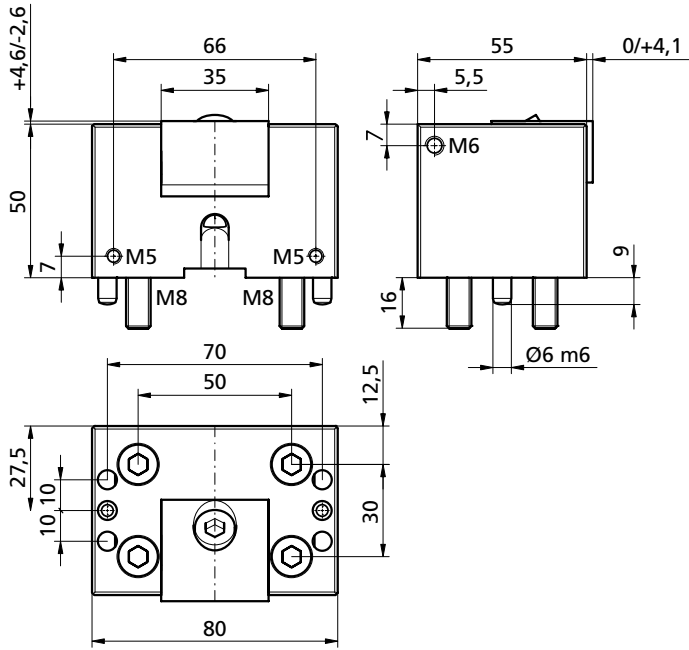

VS1R80N50-60	
1	1x TF140737
2	1x
3	1x M8X20ISO4762
4	2x FED0618
5	2x CCBO0803
6	4x M8X55ISO4762
7	2x M5X8ISO7380
8	2x CCD004
9	2x M5X12ISO7380
kg	~1,6

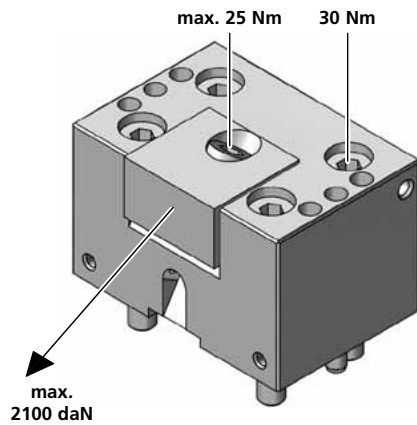

Bestellbeispiel / Ordering example: 1xVS1R80N50-60 & 1x B61

	B58	B60	B61	B62	B62HM	B65	B66	B67	B68	B69	B77	B79F	B79R
C	35	35	35	35	35	35	35	35	35	35	35	35	35
H	20	20	20	20	20	20	20	20	20	25	20	20	20
L	26	19	19	19	19	19	19	24	26	22	22	25	25
D	9	9	9	9	9	9	9	9	9	9	9	9	9
ø	12	12	12	12	12	12	12	12	12	12	12	12	12
i	ALU	56HRC	56HRC	*	HM	HV700 x0,2mm	HV700 x0,2mm	HV700 x0,2mm	*	*	56HRC	HV700 x0,2mm	HV700 x0,2mm
kg	~0,07	~0,12	~0,12	~0,12	~0,12	~0,12	~0,12	~0,14	~0,15	~0,15	~0,12	~0,18	~0,18

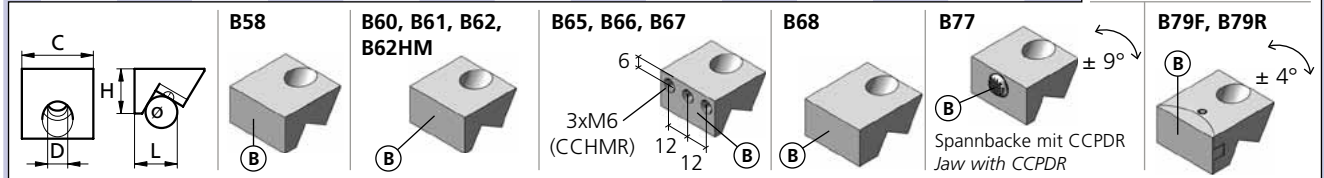
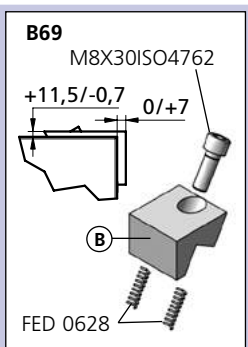





# VS1R/F125N49-95

microCLAMP

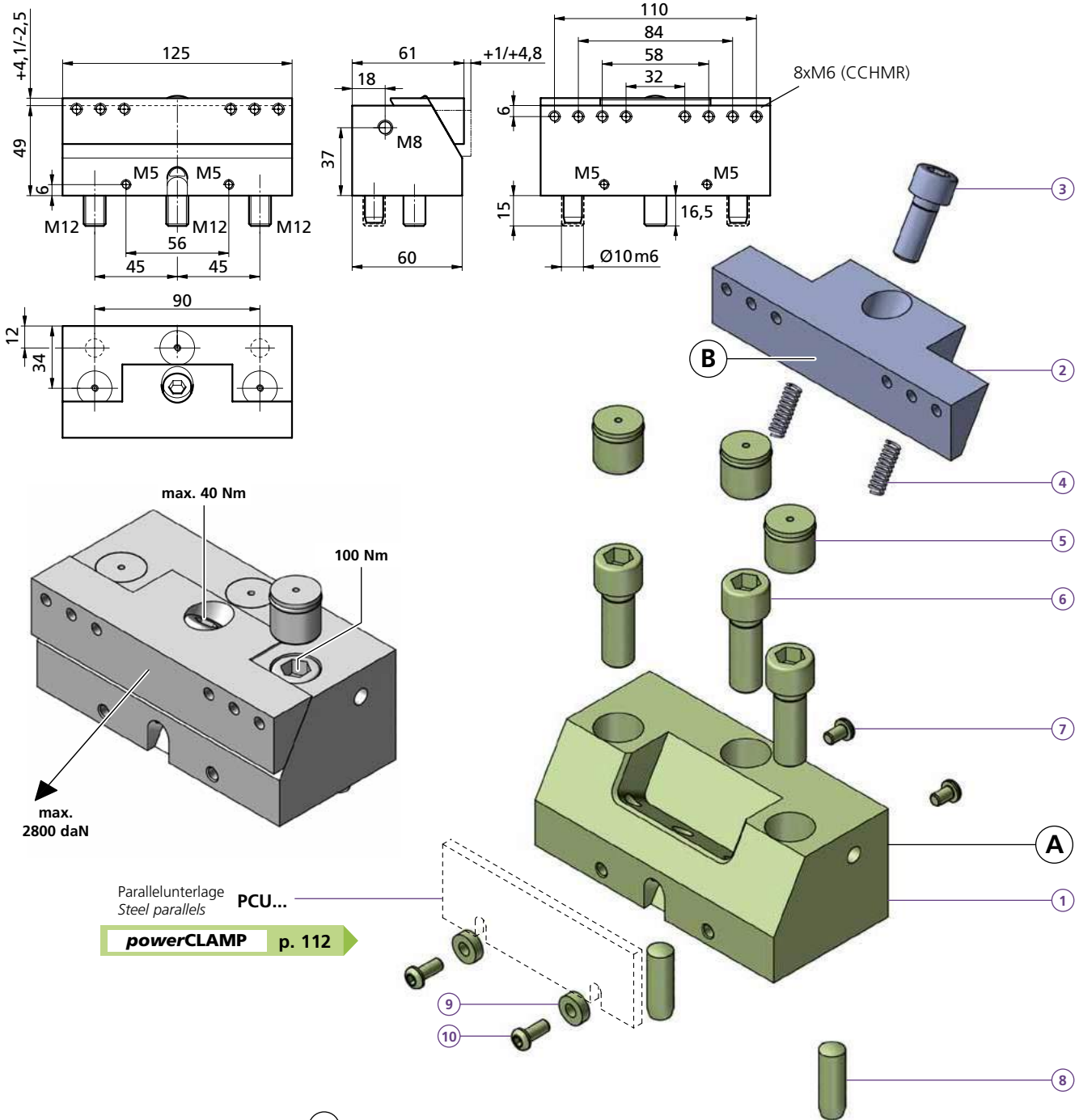

Parallelunterlage  
Steel parallels

**powerCLAMP** p. 112

Bestellbeispiel / Ordering example: 1x VS1R125N49-95 & 1x B96

	B95	B96	B97	B98	B99
<b>VS1F125N49-95</b>					
① 1x TF140738					
<b>VS1R125N49-95</b>					
① 1x TF140739					
② 1x					
③ 1x M10X25ISO4762					
④ 2x FED0618					
⑤ 3x PCPF16L18Alu					
⑥ 3x M12X35ISO4762					
⑦ 3x M5X8ISO7380					
⑧ 2x 10m6x30 DIN6325					
⑨ 2x CCD004					
⑩ 2x M5X12ISO7380					
kg	~2,6				

	B95	B96	B97	B98	B99
ⓐ	125	125	125	125	125
ⓑ	25	25	25	25	25
ⓒ	23	23	23	30	23
ⓓ	11	11	11	11	11
ⓔ	15	15	15	15	15
ⓖ	HV700	HV700	*	*	HV700
	x0,2mm	x0,2mm			x0,2mm
kg	~0,45	~0,45	~0,45	~0,63	~0,45

**B95, B96, B97, B99**

**B98**

\* = weicher Stahl / soft steel

Separat bestellen / Separate order



# VS2R80N30-60

microCLAMP

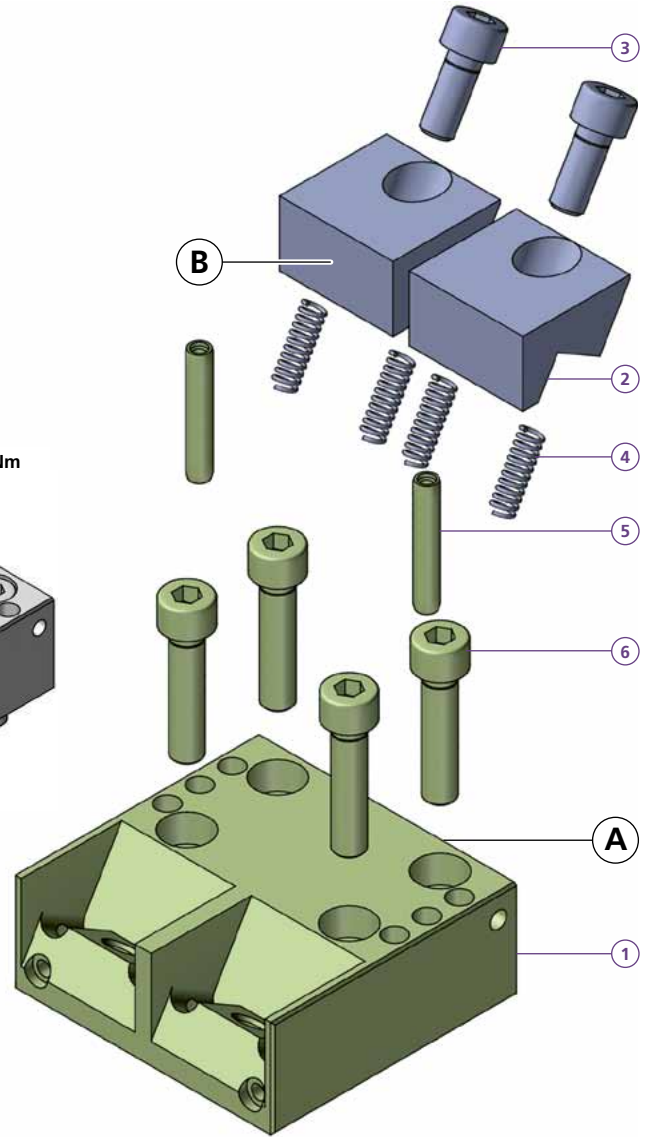
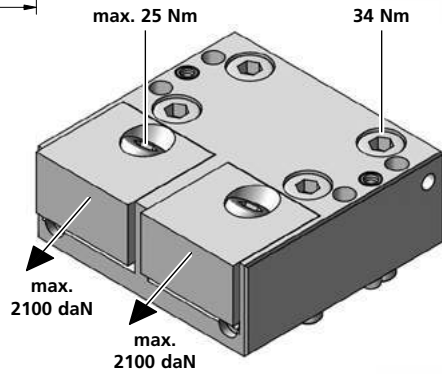
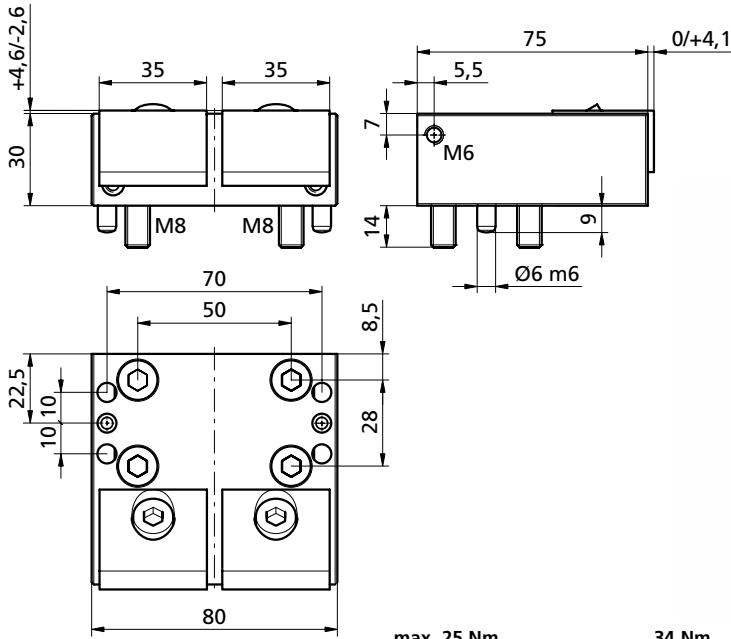

VS2R80N30-60	
1	1x TF140740
2	2x
3	2x M8X20ISO4762
4	4x FED0618
5	2x CCBO0801
6	4x M8X35ISO4762
kg	~1,3

Bestellbeispiel / Ordering example: 1x VS2R80N30-60 & 2x B61

	B58	B60	B61	B62	B62HM	B65	B66	B67	B68	B77	B79F	B79R
C	35	35	35	35	35	35	35	35	35	35	35	35
H	20	20	20	20	20	20	20	20	20	20	20	20
L	26	19	19	19	19	19	19	24	26	22	25	25
D	9	9	9	9	9	9	9	9	9	9	9	9
ø	12	12	12	12	12	12	12	12	12	12	12	12
i	ALU	56HRC	56HRC	*	HM	HV700	HV700	HV700	*	56HRC	HV700	HV700
		x0,2mm	x0,2mm			x0,2mm	x0,2mm	x0,2mm			x0,2mm	x0,2mm
kg	~0,07	~0,12	~0,12	~0,12	~0,12	~0,12	~0,12	~0,14	~0,15	~0,12	~0,18	~0,18

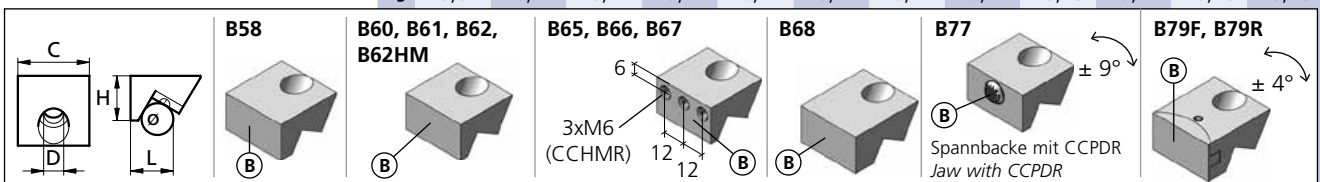



# VS2F90N30-60

microCLAMP

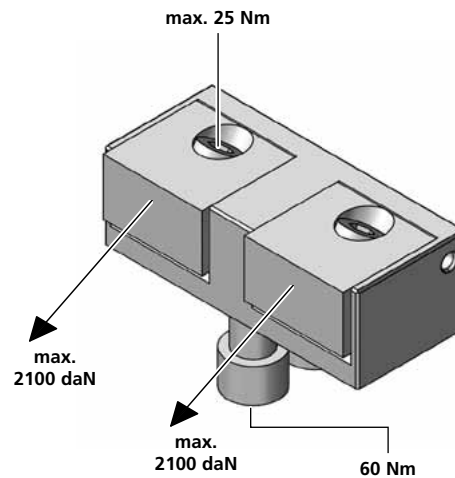
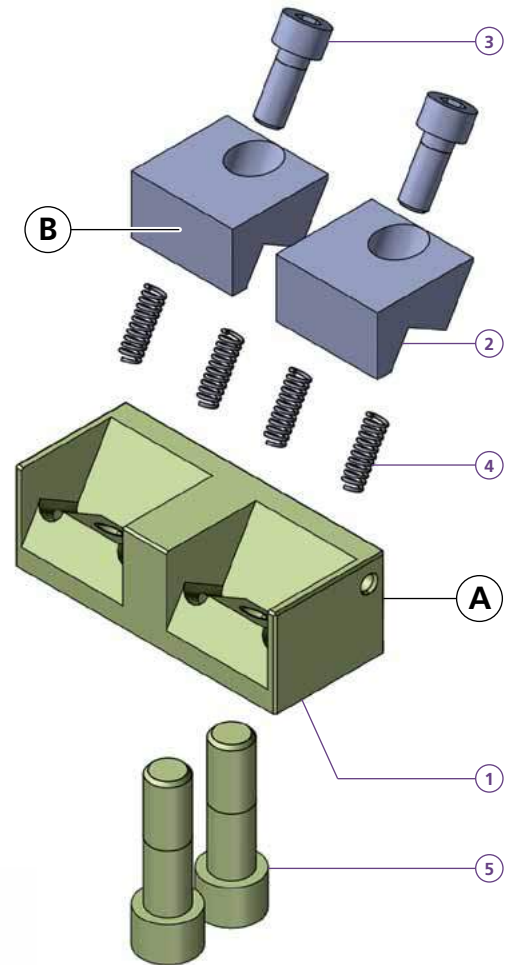
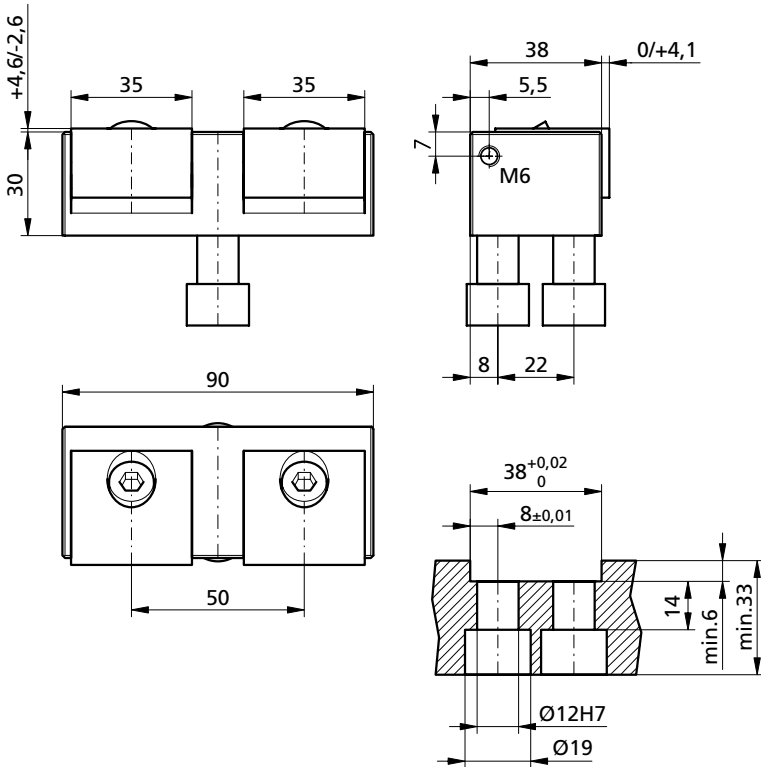

VS2F90N30-60	
1	1x TF140741
2	2x
3	2x M8X20ISO4762
4	4x FED0618
5	2x TWPAS1232
kg	~0,85

Bestellbeispiel / Ordering example: 1x VS2F90N30-60 & 2x B61

	B58	B60	B61	B62	B62HM	B65	B66	B67	B68	B77	B79F	B79R
C	35	35	35	35	35	35	35	35	35	35	35	35
H	20	20	20	20	20	20	20	20	20	20	20	20
L	26	19	19	19	19	19	19	24	26	22	25	25
D	9	9	9	9	9	9	9	9	9	9	9	9
ø	12	12	12	12	12	12	12	12	12	12	12	12
i	ALU	56HRC	56HRC	*	HM	HV700	HV700	HV700	*	56HRC	HV700	HV700
		x0,2mm	x0,2mm			x0,2mm	x0,2mm	x0,2mm			x0,2mm	x0,2mm
kg	~0,07	~0,12	~0,12	~0,12	~0,12	~0,12	~0,12	~0,14	~0,15	~0,12	~0,18	~0,18

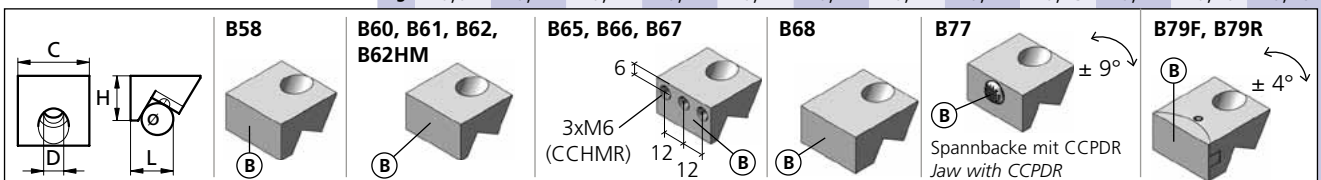

\* = weicher Stahl / soft steel

HM = Hartmetallbeschichtet / Carbide coated

ALU = ENAW-7022



**MS1R/F35L14-152**

**\*MS1R/F35L14-150\* (Alte Version / Old Version)**

**microCLAMP**

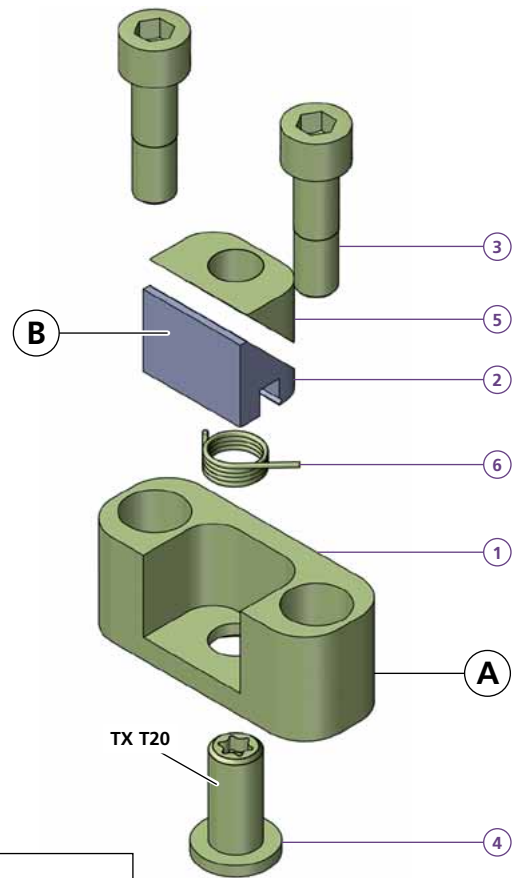
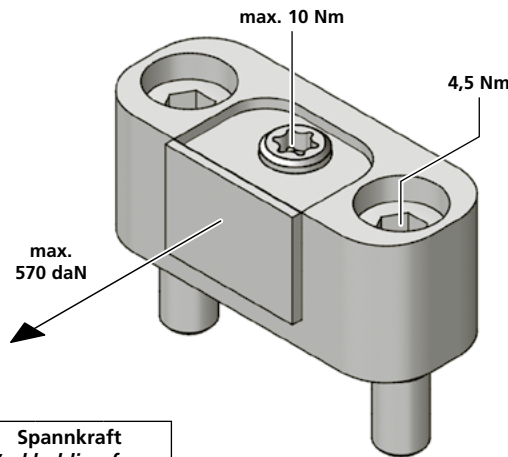
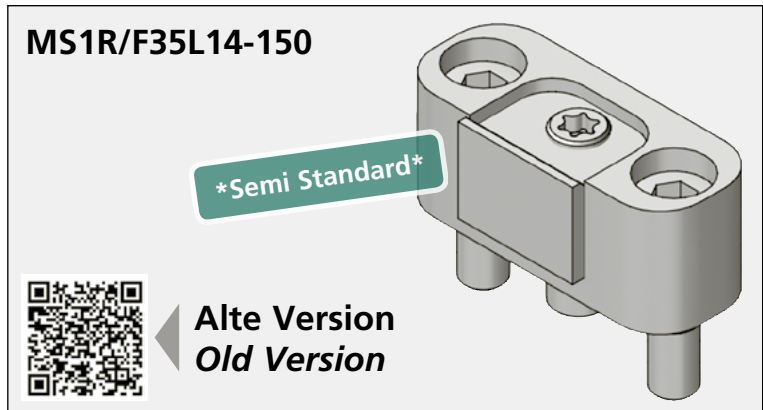
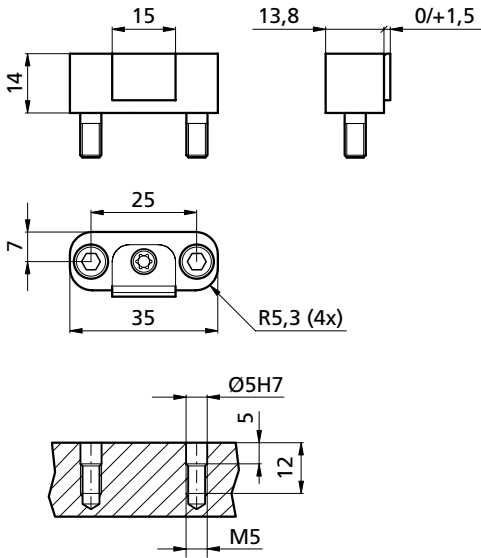

Drehmoment Torque		Spannkraft Workholding force		
Nm	(lb-ft)	~daN	~(lb)	~t
7	5,18	= 390	860	0,39
8	5,92	= 450	990	0,45
9	6,66	= 510	1120	0,51
10	7,4	= 570	1250	0,57

**Achtung:** Bei Spannkraften über 400 daN (0,4t) muss das Spannmodul in eine Nut eingelassen werden (Nuttiefe mindestens 1mm)

**Remark:** Using forces higher than 400 daN, clamps must be mounted into a slot (depth minimum 1mm)

Vorrichtungsplatte / Fixture plate

<b>A</b>	<b>MS1F35L14-152</b>
1	1x TK181266
<b>B</b>	<b>MS1R35L14-152</b>
1	1x TF190596
2	1x _____
3	2x MS50
4	1x GEWST6L14
5	1x MSK15W45
6	1x SFED6W90
kg	~0,03

Bestellbeispiel / Ordering example: 1x MS1F35L14-152 & 1x B151

<b>B</b>	<b>B150</b>	<b>B151</b>
<b>C</b>	15	15
<b>H</b>	11	11
<b>L</b>	40,3	40,3
<b>ø</b>	40	40
<b>i</b>	HV700	HV700
	x0,2mm	x0,2mm
kg	~0,004	~0,004

Separat bestellen / Separate order

VS1R26L35-31

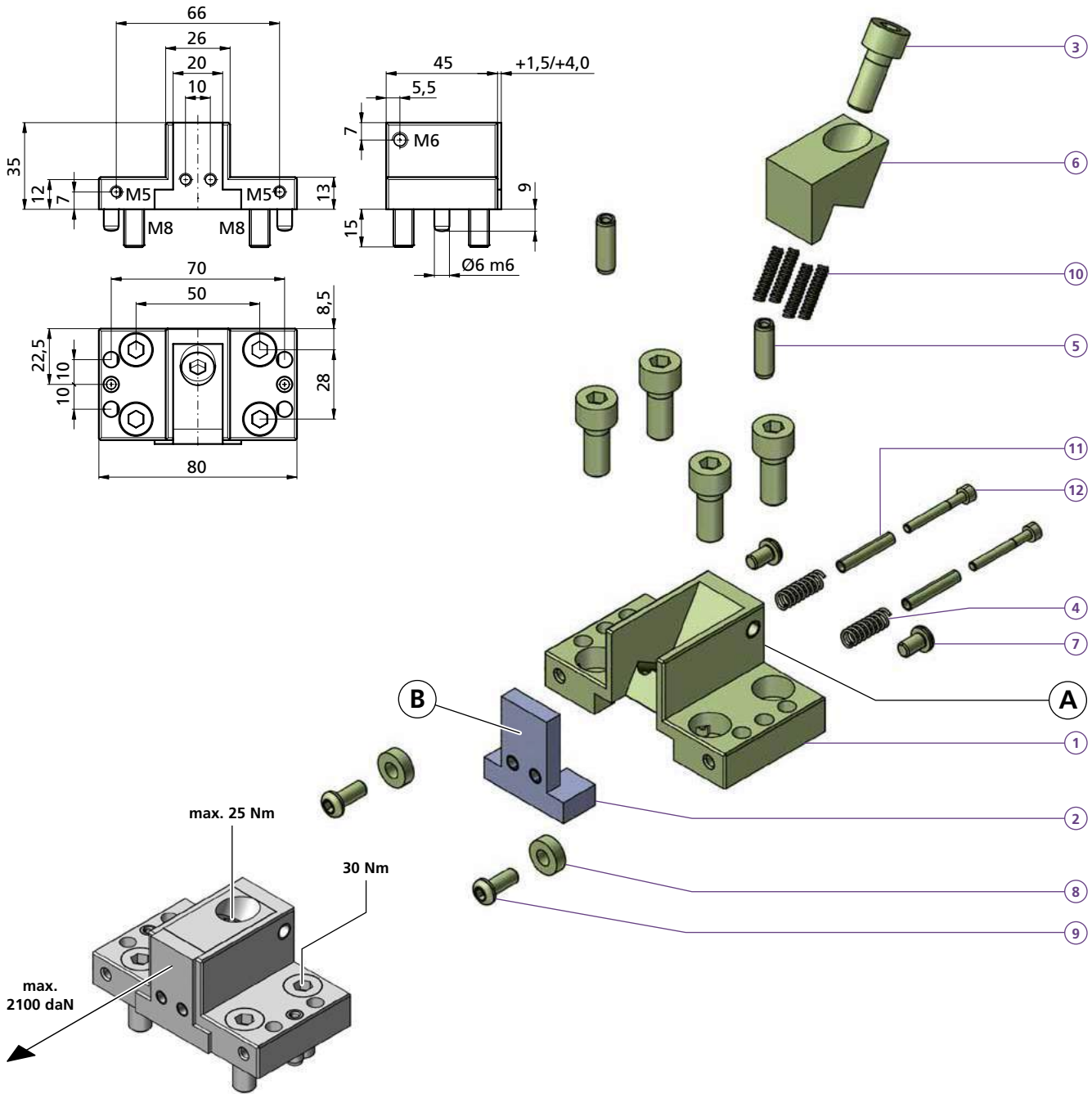

VS1R26L35-31 	
1	1x TF140724
2	1x
3	5x M8X20ISO4762
4	2x FED0618
5	2x CCBO0802
6	1x B30
7	2x M5X8ISO7380
8	2x CCD004
9	2x M5X12ISO7380
10	4x FED0418
11	2x CCD422
12	2x M3X25ISO4762
kg	~0,55

Bestellbeispiel / Ordering example: 1x VS1R26L35-31 & 1x B32

	B31	B32	B33
C	20	20	20
H	35	35	35
L	6	6	6
D	-	-	-
e	-	-	-
i	HV700 x0,2mm	HV700 x0,2mm	*
kg	~0,046	~0,046	~0,046

**B31, B32, B33**

\* = weicher Stahl / soft steel

Separat bestellen / Separate order

VS1R/F41L30-51

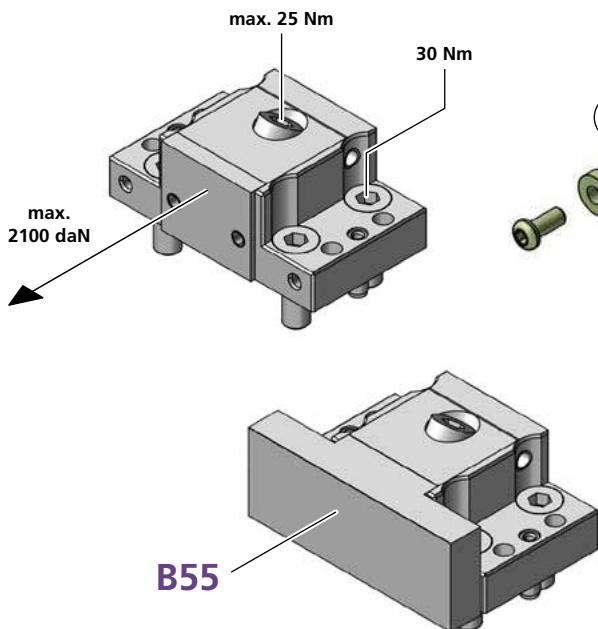
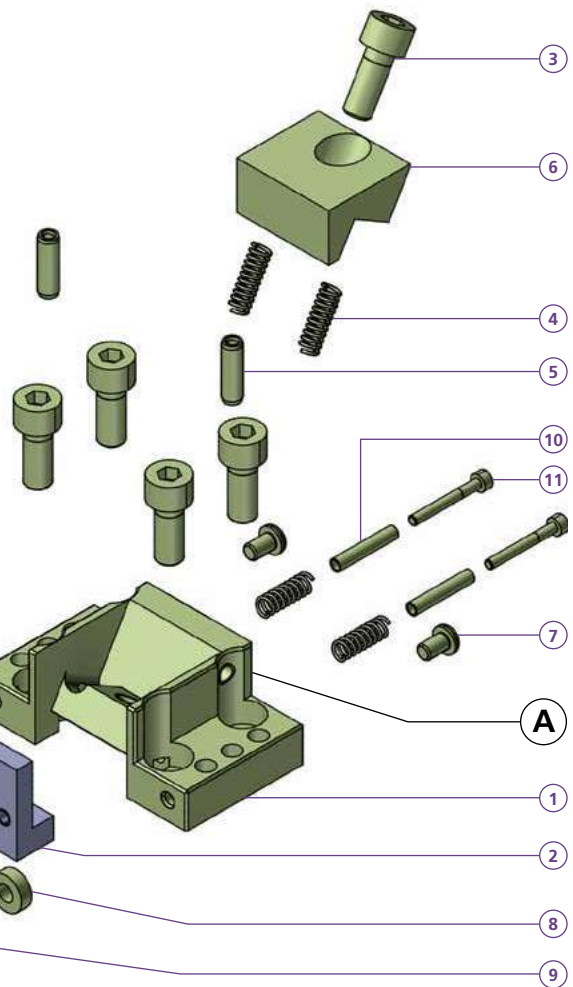
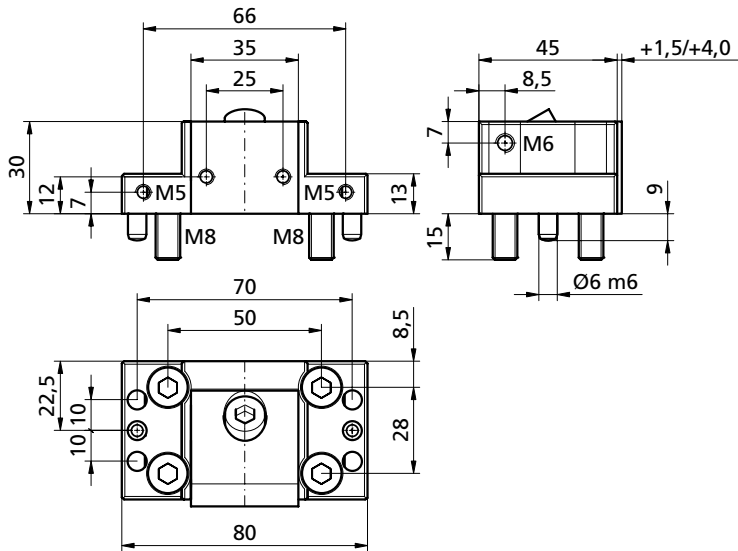

**B** Bestellbeispiel / Ordering example: 1x VS1R41L30-51 & 1x B52

VS1F41L30-51	
1	1x TF140727
VS1R41L30-51	
1	1x TF140728
2	1x
3	5x M8X20ISO4762
4	4x FED0618
5	2x CCBO0802
6	1x B78
7	2x M5X8ISO7380
8	2x CCD004
9	2x M5X12ISO7380
10	2x CCD422
11	2x M3X25ISO4762
kg	~0,545

	B51	B52	B53	B54	B55
C	35	35	35	35	80
H	30	30	30	35	30
L	6	6	10	10	11,5
D	-	-	-	-	-
e	-	-	-	-	-
i	HV700	HV700	*	*	*
	x0,2mm	x0,2mm			
kg	~0,06	~0,06	~0,06	~0,12	~0,27

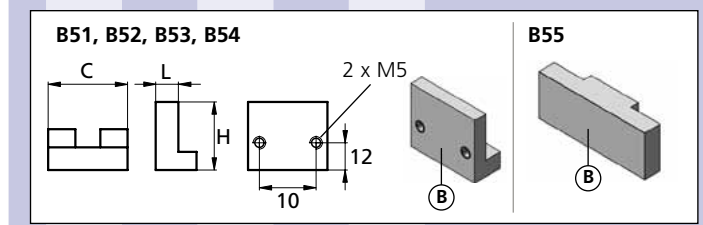

Separat bestellen / Separate order



**Vorrichtungsbau-Modul für Linearbacken**

Alle bestehenden Linearbacken passen auf dieses Modul (powerCLAMP Seite 84 - 83). In die Vorrichtungsplatte wird eine Tasche gefräst um das Modul zu positionieren. Gut geeignet sind die Anschlagbacken MAND und MANF um als Gegenbacke zu dienen.

**Fixture clamp module for linear jaws**

All of our standard linear jaws fit to this clamp module (powerCLAMP Page 84 - 83). All to do is milling a pocket to fit and positioning the clamp modules. To use the MAND and MANF as datum stop will make a perfect match. (Seite / Page 175 - 176)

**Fertigungsmasse für die Vorrichtungsplatte**  
Machining data for the fixture plate

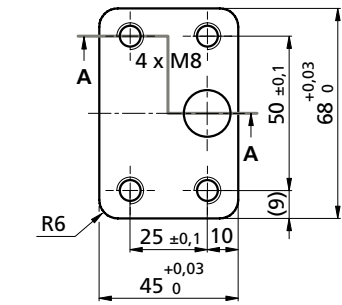

**Schnitt / Section A-A**

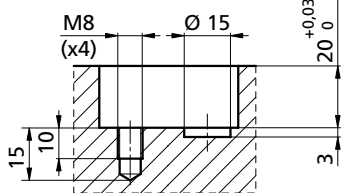

Das Fertigungsmass gilt auch für das Anschlagmodul.  
The production dimension is also valid for the end module. (VA168-20PRG)

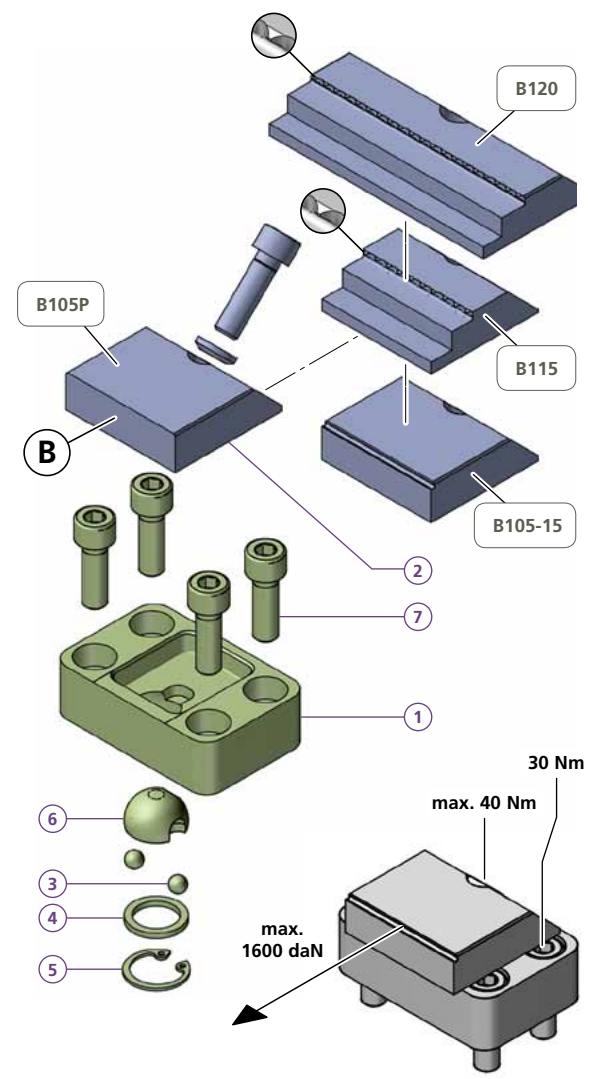
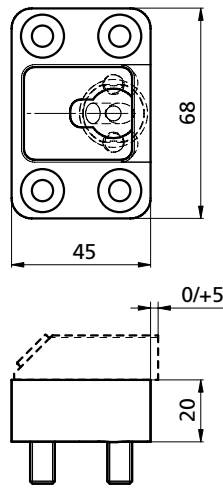

VS1X68L20-105	
1	1x TB150170
2	1x <b>powerCLAMP</b> p 82, 83, 84
3	1x BN869d=6
4	1x TN100747
5	1x TN100779
6	1x PCKMR45M8
7	4x M8X20ISO4762
kg	~0,42

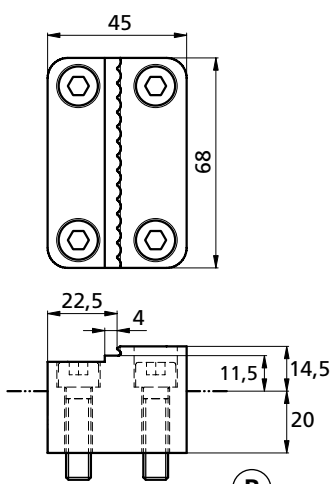

VA168-20PRG	
8	1x TH160280
9	4x M8X30ISO4762
kg	~0,75

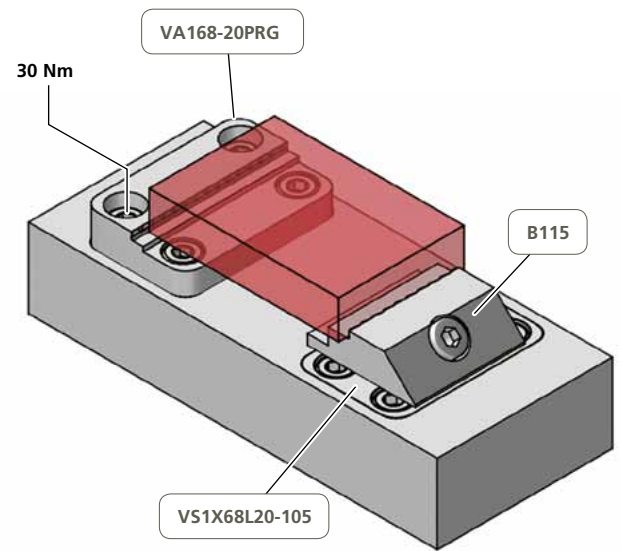
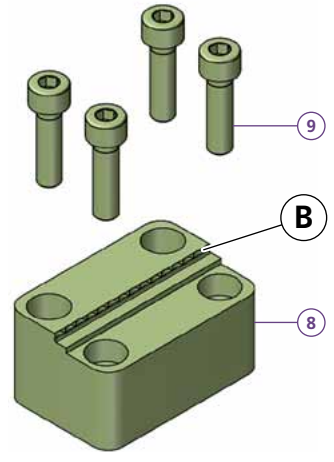



Bestellbeispiel / Ordering example: 1x VS1X68L20-105 & 1x B105P

Separat bestellen / Separate order

**VS1F48L50-105**

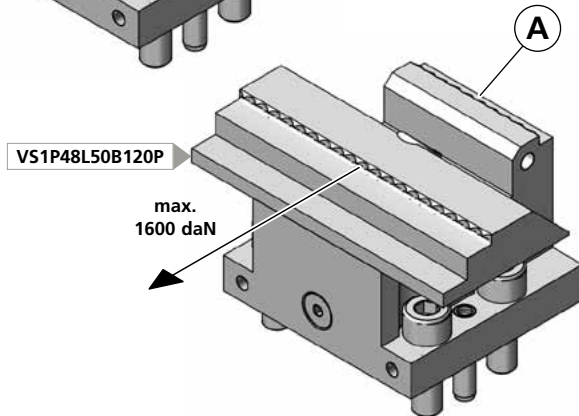
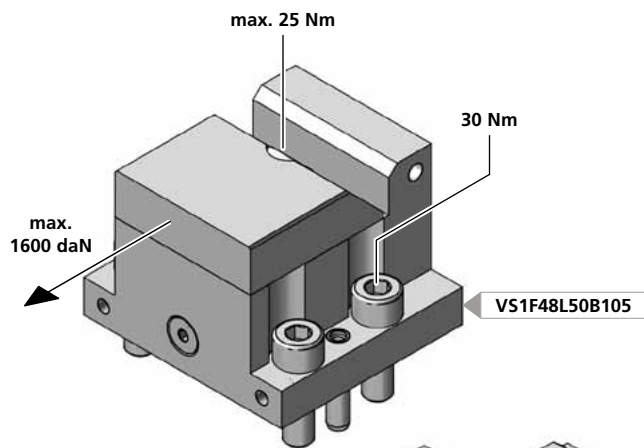
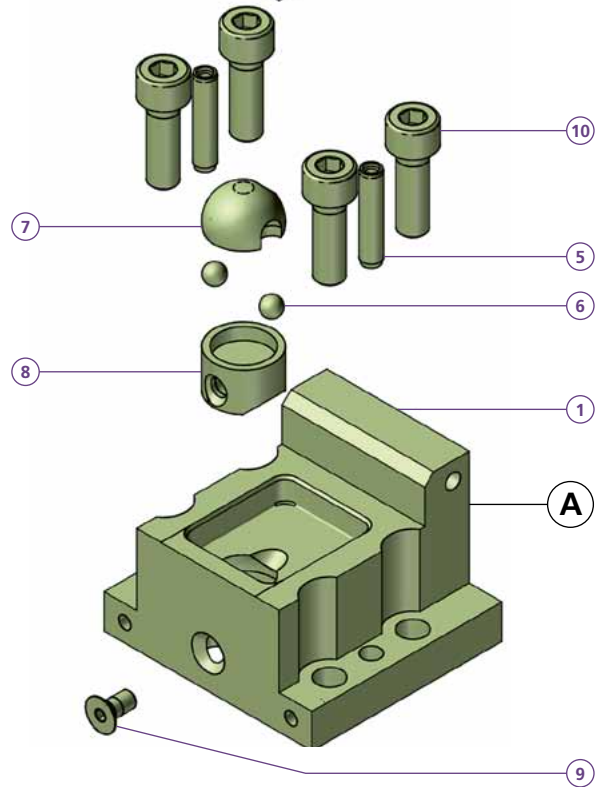
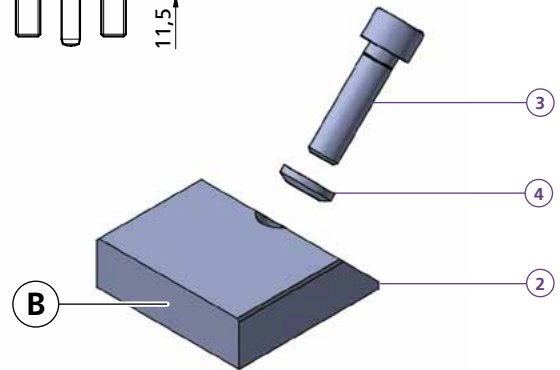
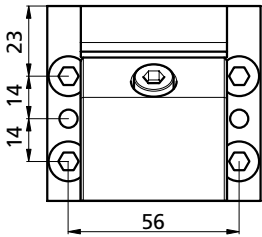
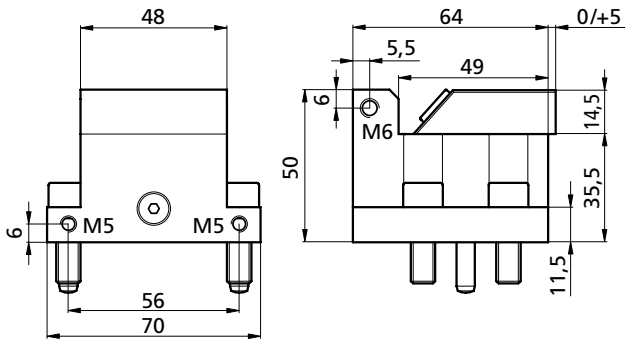
**VS1P48L50-105**



<b>VS1F48L50-105</b>	
1 1x TK120807	
<b>VS1P48L50-105</b>	
1 1x TK120761	
2 1x	<b>powerCLAMP</b> p. 84
3 1x M8X30ISO4762	
4 1x PCUSR14	
5 1x 6-m6x26 DIN 79790	
6 2x BN869d=6	
7 1x PCKMR45M8	
8 2x TS120001-04	
9 1x M5X10DIN7991	
10 4x M8X25ISO4762	
kg ~1,21	

Bestellbeispiel / Ordering example: 1x VS1F48L50-105 & 1x B105

Separat bestellen / Separate order

VS1R/F80L30-51

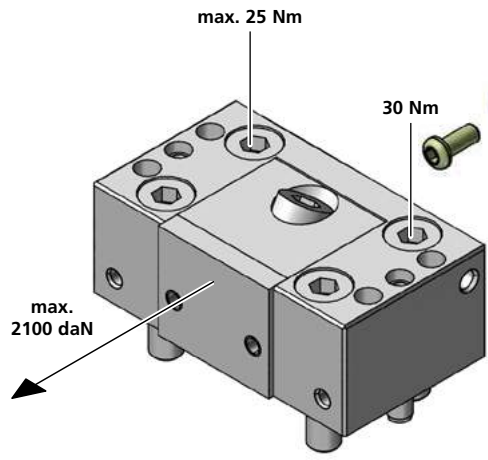
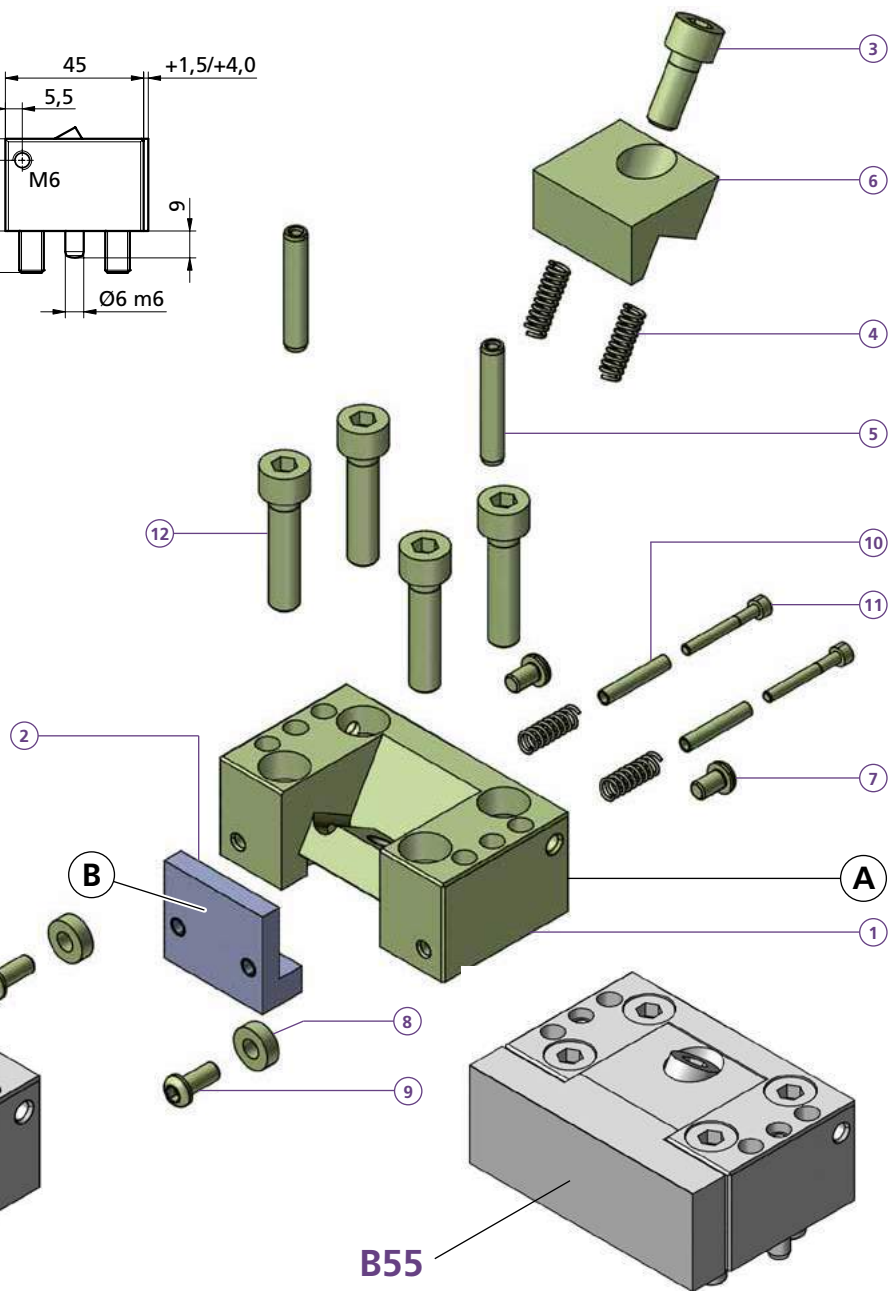
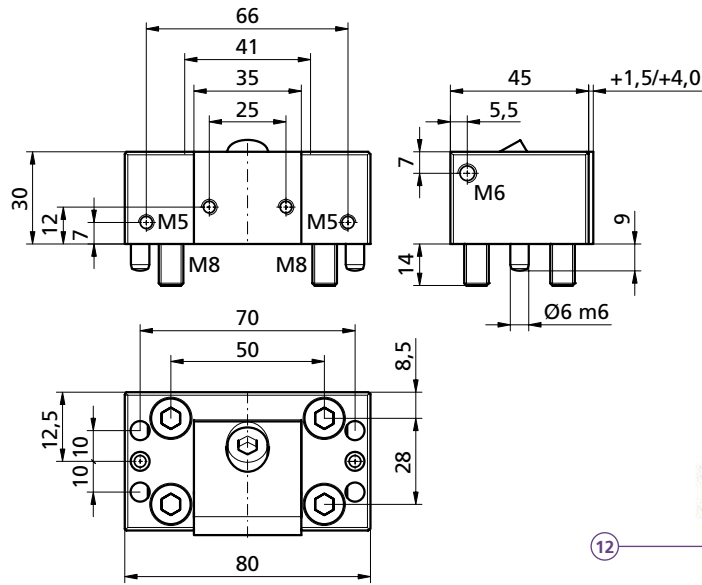

- |                     |                 |
|---------------------|-----------------|
| <b>VS1F80L30-51</b> |                 |
| 1                   | 1x TF140731     |
| <b>VS1R80L30-51</b> |                 |
| 1                   | 1x TF140732     |
| 2                   | 1x              |
| 3                   | 1x M8X20ISO4762 |
| 4                   | 4x FED0618      |
| 5                   | 2x CCBO0801     |
| 6                   | 1x B78          |
| 7                   | 2x M5X8ISO7380  |
| 8                   | 2x CCD004       |
| 9                   | 2x M5X12ISO7380 |
| 10                  | 2x CCD422       |
| 11                  | 2x M3X25ISO4762 |
| 12                  | 4x M8X35ISO4762 |
| kg                  | ~0,74           |

**B** Bestellbeispiel / Ordering example: 1x VS1R80L30-51 & 1x B52

	B51	B52	B53	B54	B55
<b>C</b>	35	35	35	35	80
<b>H</b>	30	30	30	35	30
<b>L</b>	6	6	10	10	11,5
<b>D</b>	-	-	-	-	-
<b>e</b>	-	-	-	-	-
<b>i</b>	HV700 x0,2mm	HV700 x0,2mm	*	*	*
<b>kg</b>	~0,06	~0,06	~0,06	~0,12	~0,27

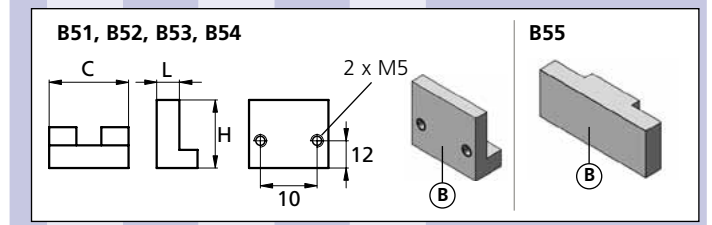

\* = weicher Stahl / soft steel

Separat bestellen / Separate order



**VS1X59L60K**

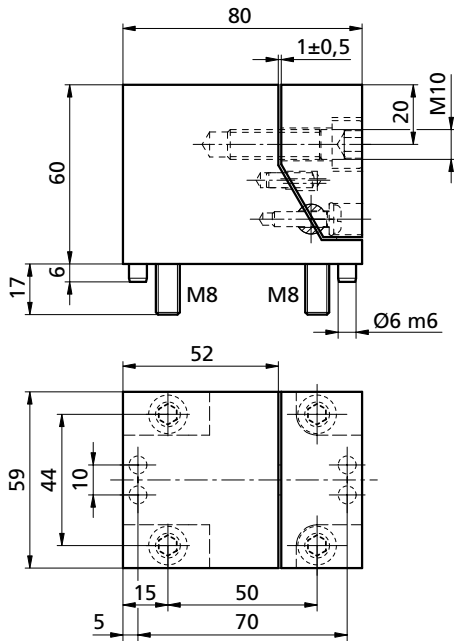

Empfohlener Sechskantschlüssel  
Recommended hexagon wrench  
**PB2212L/6**

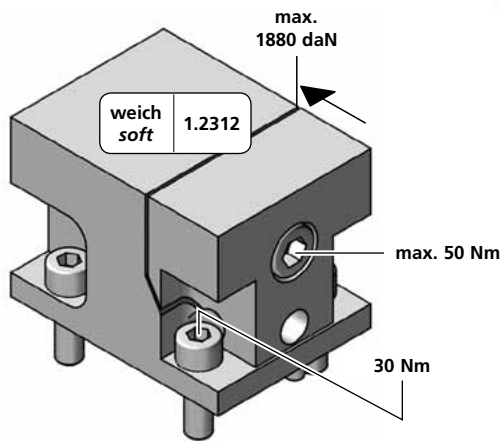
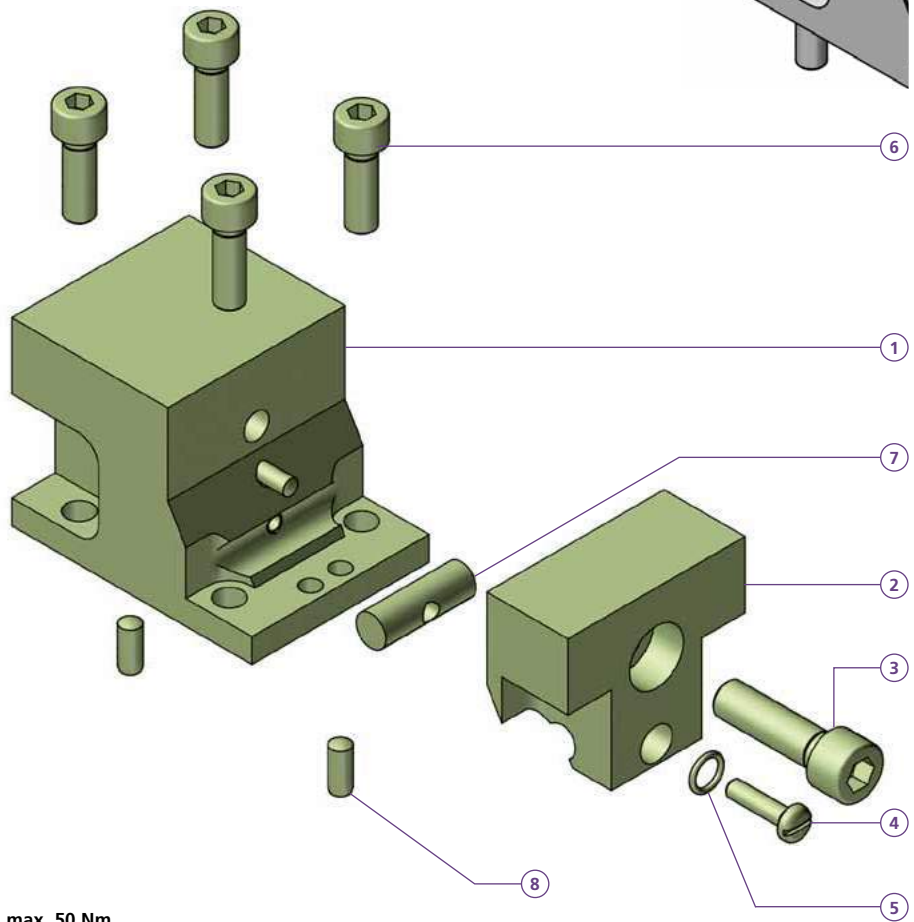

Spannstelle an Werkstück angepasst und nitriert.  
Clamping face machined to the shape of the workpiece and nitrided.

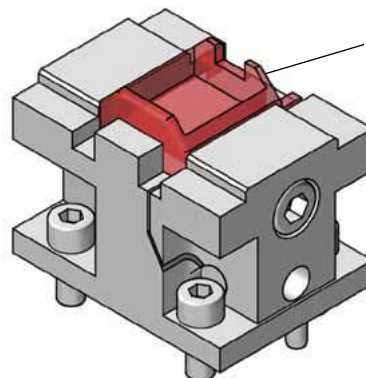

*VS1X59L60K	
1	1x VS1X59L60H5KA
2	1x VS1X59L60H5KS
3	1x M10X35ISO4762
4	1x M5X20DIN85A
5	1x ORØ8x1,5
6	4x <b>M8X25ISO4762</b>
7	1x VS1X59L60H5KG
8	2x 6m6x14 DIN 6325
kg	~1,89

VS1X59L60H5

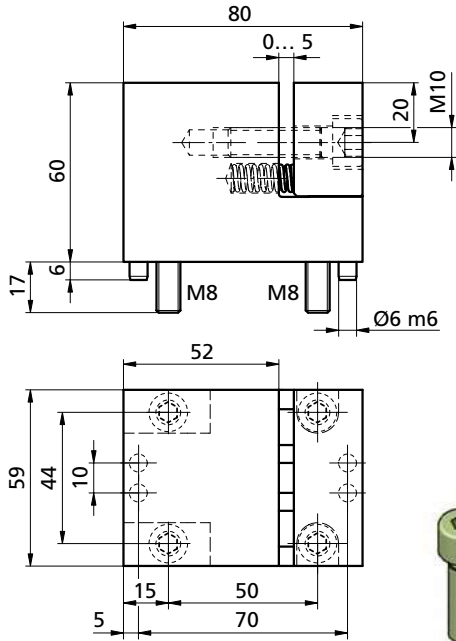

Empfohlener Sechskantschlüssel  
Recommended hexagon wrench  
**PB2212L/6**

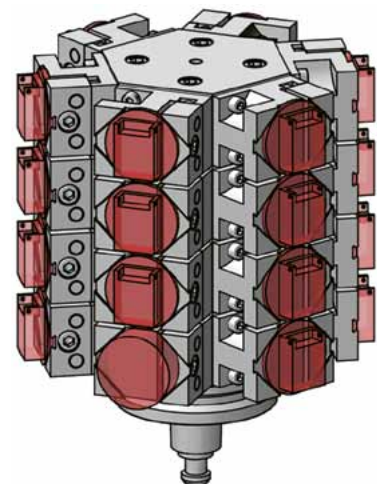
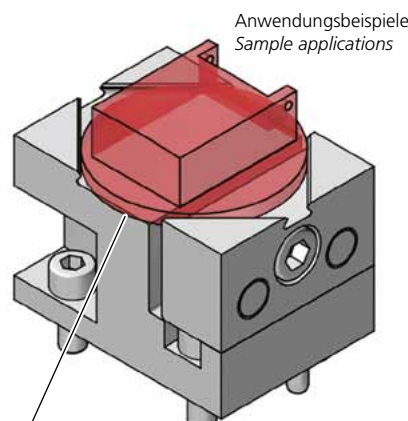
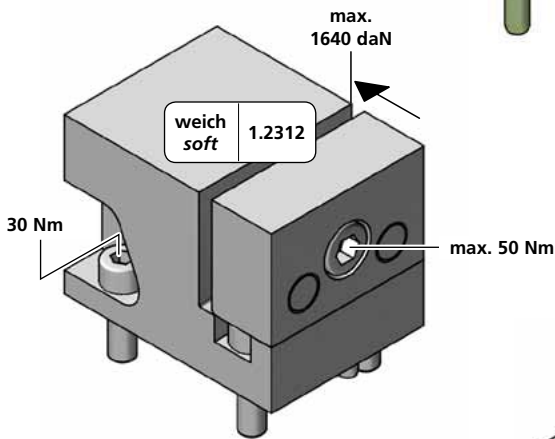
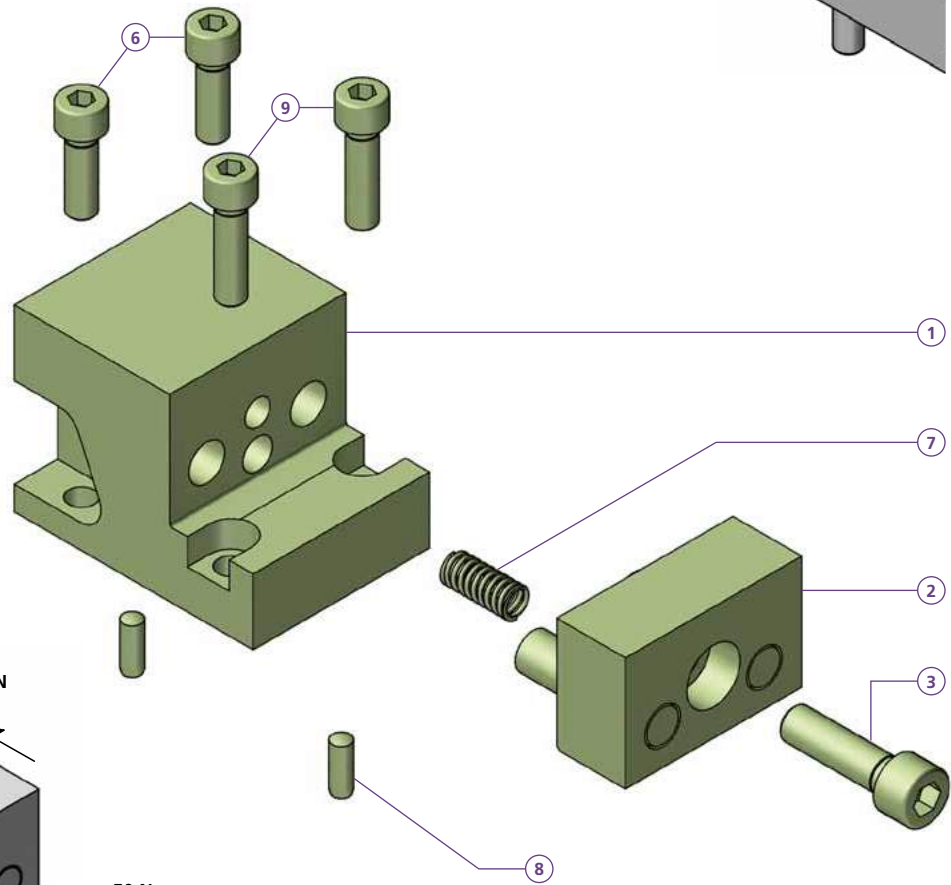
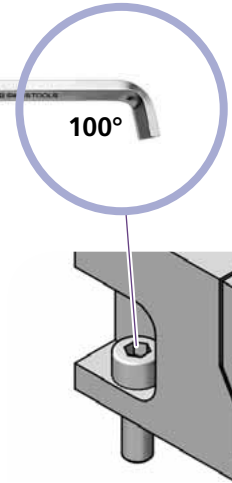

Spannstelle an Werkstück angepasst und nitriert.  
Clamping face machined to the shape of the workpiece and nitrided.

*VS1X59L60H5	
1	1x VS1X59L60H5A
2	1x VS1X59L60H5S
3	1x M10X35ISO4762
6	2x <b>M8X25ISO4762</b>
7	1x FED0833
8	2x 6m6x14 DIN 6325
9	2x <b>M8X30ISO4762</b>
kg	~1,94

\* = Stahl / steel 1.2312

Bestellbeispiel / Ordering example : VS1X59L60H5

Separat bestellen / Separate order



durchgehärtet / through hardened										nitriert / nitrated									
<b>26mm</b>	<b>B</b>	<b>H</b>	<b>N</b>	<b>kg</b>	<b>41mm</b>	<b>B</b>	<b>H</b>	<b>N</b>	<b>kg</b>	<b>23mm</b>	<b>B</b>	<b>H</b>	<b>N</b>	<b>kg</b>	<b>41mm</b>	<b>B</b>	<b>H</b>	<b>N</b>	<b>kg</b>
CCU15026	26	15	2,2	~0,017	CCU15081	41	15	2,2	~0,018	MCU11037	23	11	2	~0,004	CCU15083	41	15	3	~0,025
CCU20026	26	20	2,2	~0,02	CCU20081	41	20	2,2	~0,022	MCU15037	23	15	2	~0,006	CCU20083	41	20	3	~0,029
CCU25026	26	25	2,2	~0,022	CCU25081	41	25	2,2	~0,025	MCU18037	23	18	2	~0,008	CCU25083	41	25	3	~0,034
CCU30026	26	30	2,2	~0,025	CCU27581	41	27	2,2	~0,027	MCU20037	23	20	2	~0,008	CCU27583	41	27,5	3	~0,036
CCU32526	26	32,5	2,2	~0,026	CCU30081	41	30	2,2	~0,029	MCU22537	23	22,5	2	~0,008					
<b>38mm</b>	<b>B</b>	<b>H</b>	<b>N</b>	<b>kg</b>	<b>80mm</b>	<b>B</b>	<b>H</b>	<b>N</b>	<b>kg</b>	<b>26mm</b>	<b>B</b>	<b>H</b>	<b>N</b>	<b>kg</b>	<b>80mm</b>	<b>B</b>	<b>H</b>	<b>N</b>	<b>kg</b>
CCU30039	38	30	2,2	~0,028	CCU15080	79	15	2,2	~0,019	CCU15027	26	15	3	~0,024	CCU15082	79	15	3	~0,026
CCU35039	38	35	2,2	~0,031	CCU20080	79	20	2,2	~0,027	CCU20027	26	20	3	~0,027	CCU20082	79	20	3	~0,036
CCU40039	38	40	2,2	~0,035	CCU25080	79	25	2,2	~0,035	CCU25027	26	25	3	~0,03	CCU25082	79	25	3	~0,045
CCU45039	38	45	2,2	~0,039	CCU27580	79	27,5	2,2	~0,039	CCU30027	26	30	3	~0,033	CCU27582	79	27,5	3	~0,049
					CCU30080	79	30	2,2	~0,043	CCU32527	26	32,5	3	~0,034					
					CCU35080	79	35	2,2	~0,05										
					CCU40080	79	40	2,2	~0,057										
					CCU45080	79	45	2,2	~0,063										

**CCU**

**MCU**

**Schraubenzieher mit Konterung für**  
**Screwdriver with holding sleeve for**

**CCBXSK**

**Positionsbolzen**  
**Position pin**

	L	kg
CCBO0801	36	~0,006
CCBO0802	20	~0,002
CCBO0803	50	~0,01

**Bolzen-Auszieher**  
**Pin puller**

**CCAZ1050**

**Positionierstift (spreizbar)**  
**Locating pin (expandable)**

**CCBX0802**

**MCZ40L30PRG13**

Mehr Informationen siehe Zentrischspanner  
For more information check the self centring vise

**p. 116**

**MCZ100L50**

Mehr Informationen siehe Zentrischspanner  
For more information check the self centring vise

**p. 127**





CC ...  
CC ... V

microCLAMP

**Universalbacke / Universal jaw**

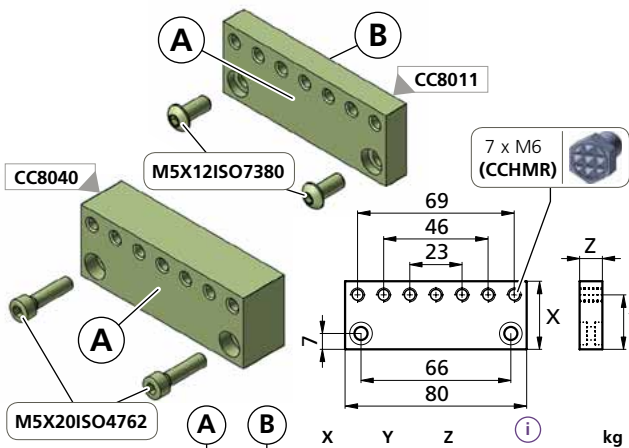

Part	A	B	X	Y	Z	Material	Weight (kg)
CC8011			30	24	10	56 HRC	~ 0,15
CC8025			50	44	10		~ 0,28
CC8040			30	24	20	*	~ 0,33

**Weiche Backe / Soft jaw**

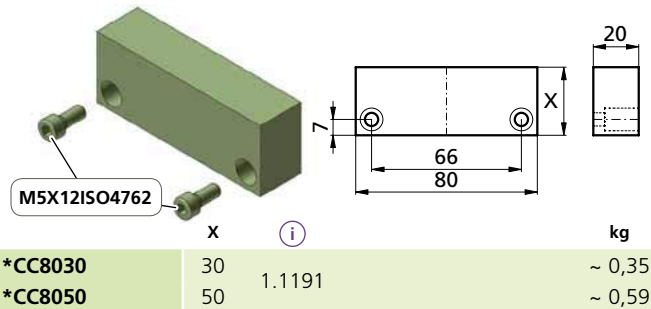

Part	X	Weight (kg)
*CC8030	30	~ 0,35
*CC8050	50	~ 0,59

**Backe mit 2 Pendeldruckstücken / Jaw with 2 swiveling balls**

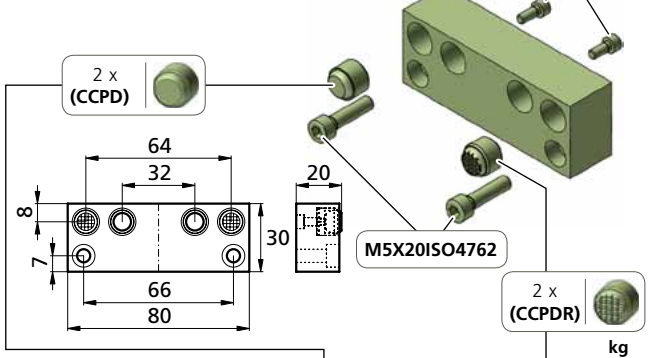

Part	Weight (kg)
CC8060	~0,30
CC8060R	~0,30

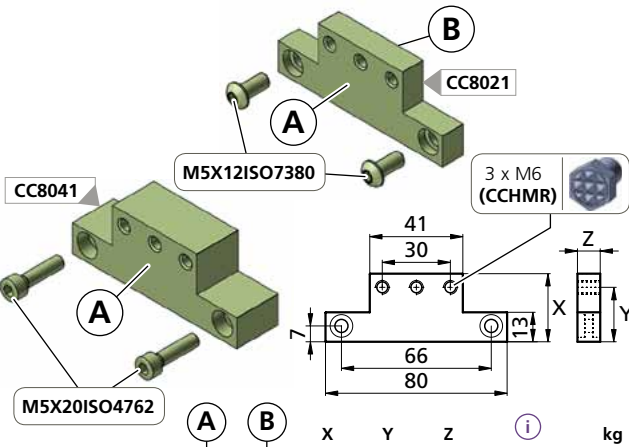

Part	A	B	X	Y	Z	Material	Weight (kg)
CC8021			30	24	10	56 HRC	~ 0,11
CC8026			50	44	10		~ 0,17
CC8041			30	24	20	*	~ 0,24

**Backe für Druckstift / Jaw for pressure pin**

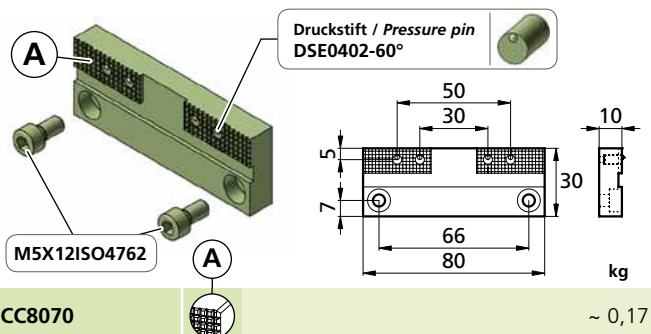

Part	Weight (kg)
CC8070	~ 0,17

**Prismabacke / Prismatic jaw**

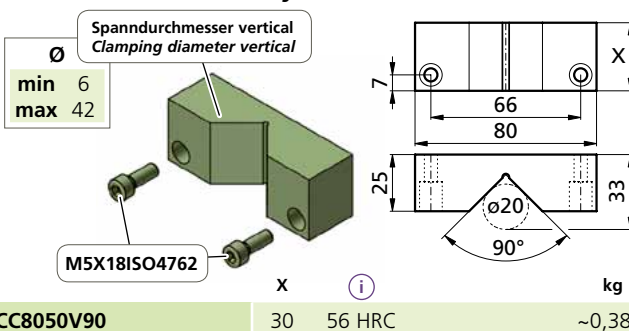

Part	X	Material	Weight (kg)
CC8050V90	30	56 HRC	~0,38

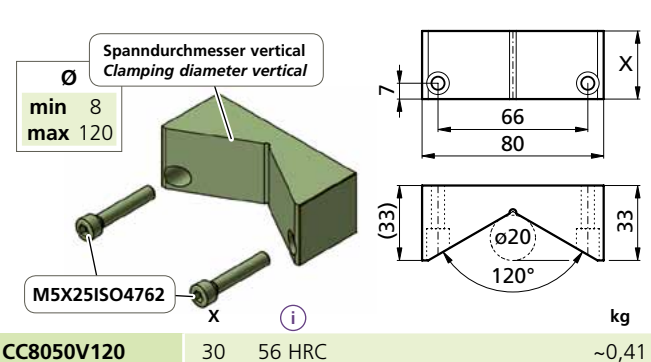

Part	X	Material	Weight (kg)
CC8050V120	30	56 HRC	~0,41

**Backe / Jaw**

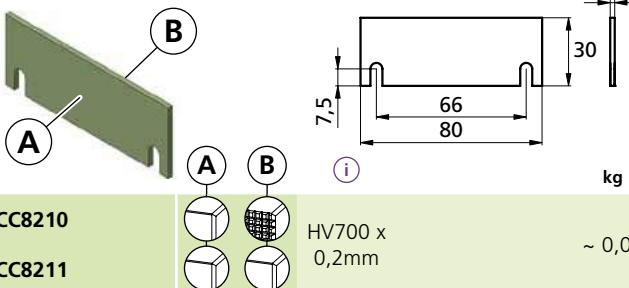

Part	A	B	Material	Weight (kg)
CC8210			HV700 x 0,2mm	~ 0,03
CC8211				

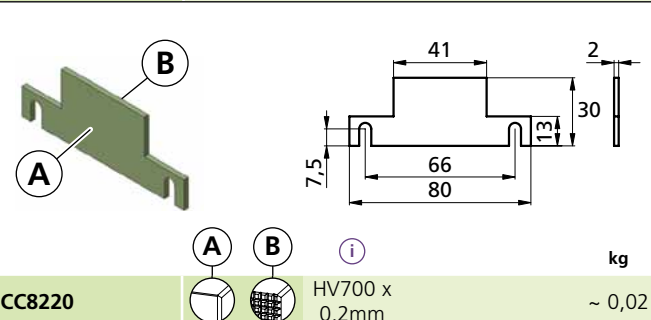

Part	A	B	Material	Weight (kg)
CC8220			HV700 x 0,2mm	~ 0,02

\* = weicher Stahl / soft steel

Bestellbeispiel / Ordering example: CC8011

Separat bestellen / Separate order



microCLAMP

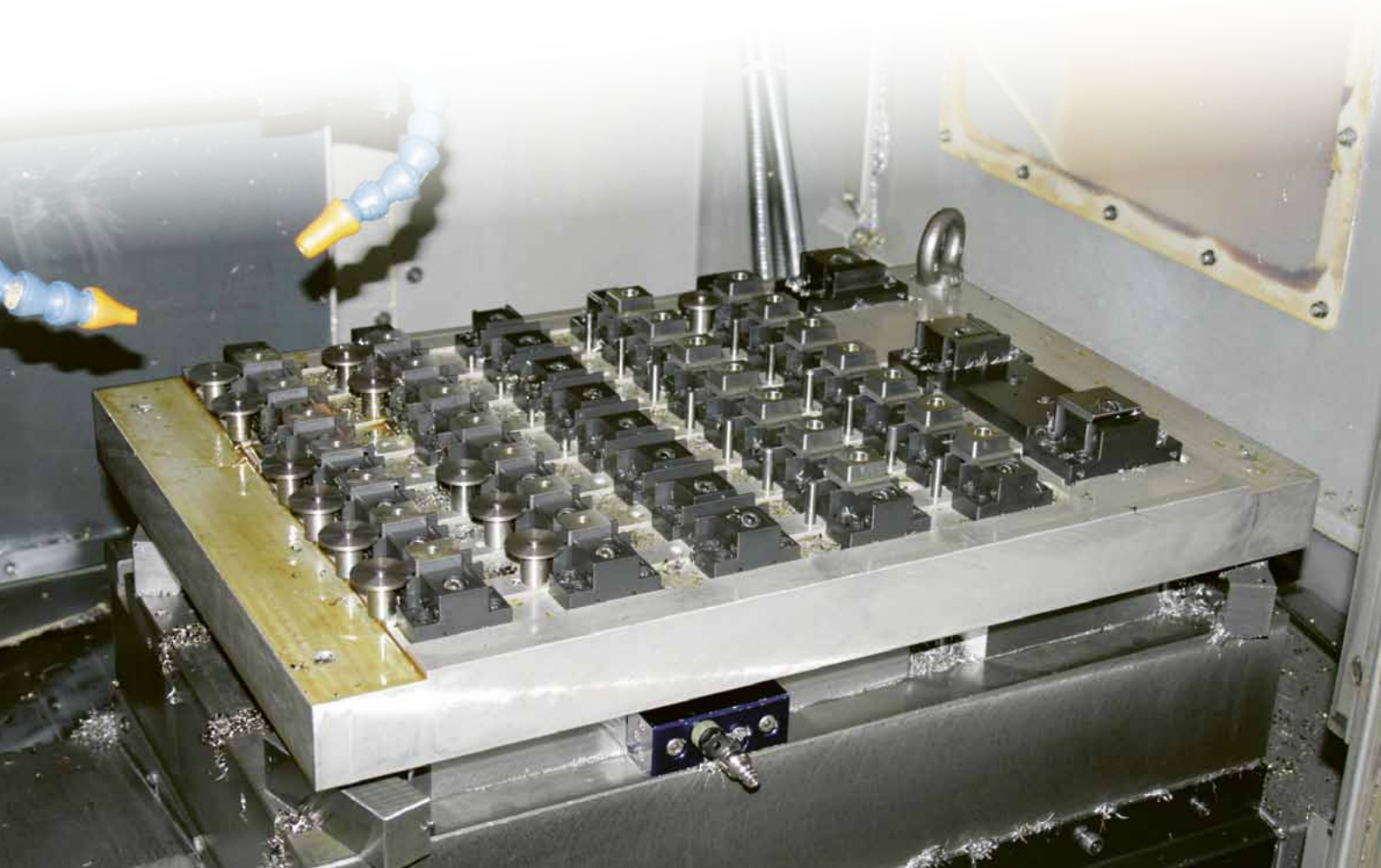
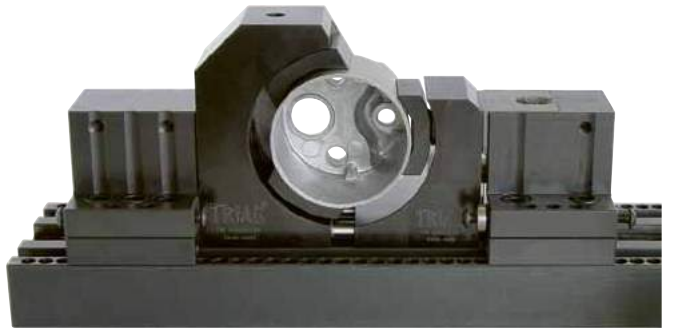
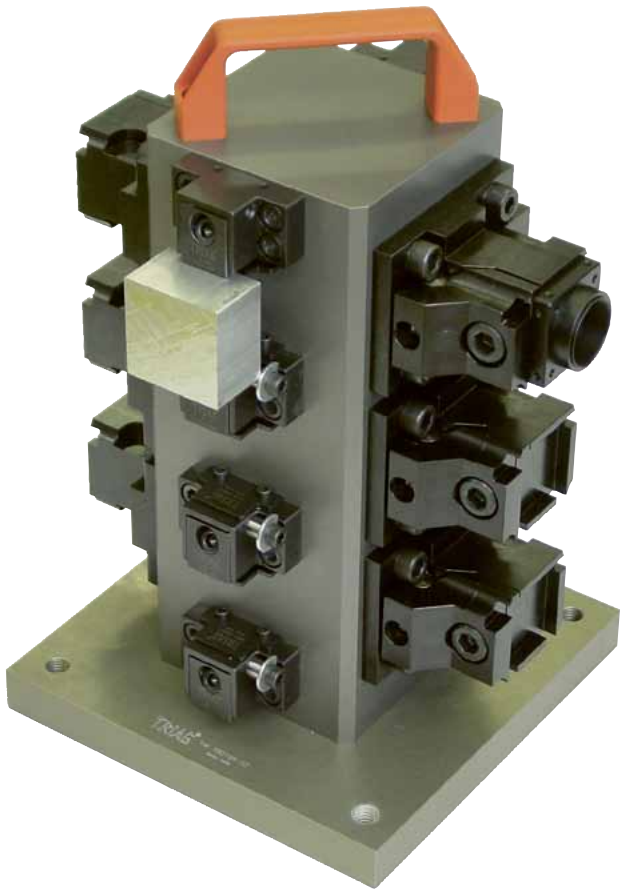



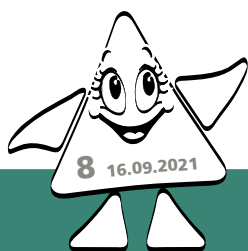

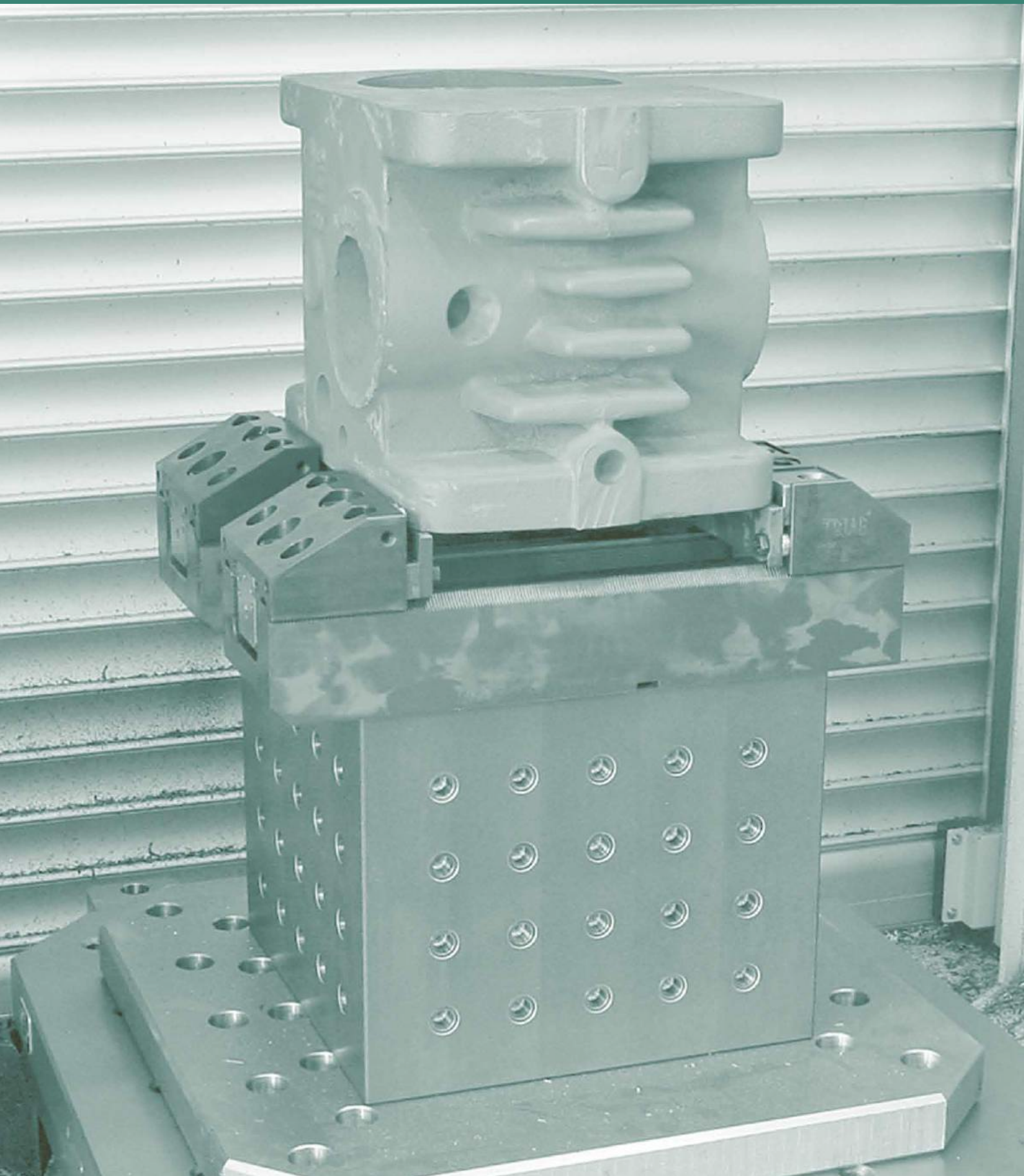

# *apto*CLAMP & 5axes





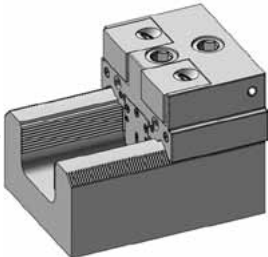
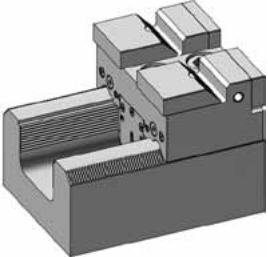
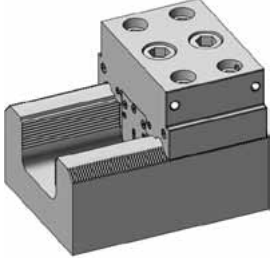
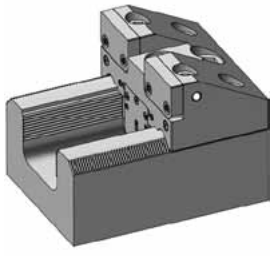
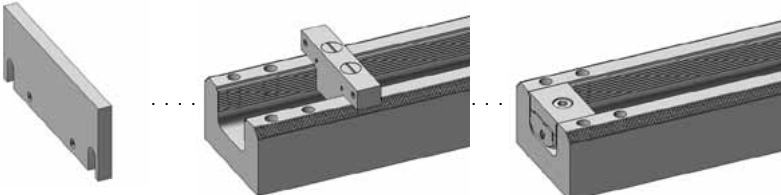

	Einleitung   <i>Introduction</i> .....	209 - 212
	Bedienungsanleitung   <i>Operating manual</i> .....	213 - 214
	Anwendungsbeispiele   <i>Examples of application</i> .....	215 - 220
	Basisschiene   <i>Base-rail</i> .....	222
		
	Niederzugspannmodule   <i>Pull down clamp modules</i> .....	223 - 226
		
	Linearspannmodule mit Präge- und Linearbacken <i>Linear clamping modules with stamping and linear jaws</i> .....	227
		
	Anschlagmodule   <i>End module</i> .....	228 - 230
		
	5-Achs Linearanschlagmodule mit Präge- und Linearbacken <i>5-axis linear clamping modules with stamping and linear jaws</i> .....	231
		
	Zubehör   <i>Accessories</i> .....	232 - 233
		



Die hohe Spannkraft dieses Systems ermöglicht den Einsatz für schwere Zerspanung.  
Mit stabilen Kraftspannern können auf den Basisschienen auch grosse, bis zu mehrere tausend Kilogramm schwere Platten und Blöcke gespannt werden.

*The high clamping force of the Apto Clamp enables heavy cuts. You achieve maximum rigidity with our Apto Clamp modular system! Even if your workpiece is thousands of kilograms you don't have to worry to clamp big parts and big plates.*

## Elefantenstark und anwenderfreundlich

### Powerful and user-friendly



Zur Positionierung der Spannmodule hat das Apto Clamp neben einer Querverzahnung zusätzlich ein Ankersystem zur Arretierung an einer Längsverzahnung in der Basischiene. Durch die rechtwinklige Verkeilung wird eine von Mitbewerbern unerreichte Stabilität gewährleistet. Die Spannmodule liegen auf der genau geschliffenen Auflagefläche der Basis auf. Durch das Ankersystem und die geschliffene Auflagefläche wird das Spannmodul an der Basischiene extrem kraftschlüssig und präzise fixiert. Trotzdem können die Spannmodule völlig ungehindert entlang der Basis verstellt (verschoben) werden. Auch das Auswechseln der Module ist einfach, müssen doch diese nicht aus der Schiene ausgefahren, sondern können abgehoben werden.

*For positioning the clamp modules on the base rails, has the Apto Clamp system next to a positioning serration a horizontal anchor system for locking with enornes force produced by two M16 screws. The end modules have additionally 4 M12 screws to give extra rigidity.*



Darum haben wir dieses Symbol gewählt:  
*That's why we have chosen this symbol:*



## Schnelligkeit / Quickness



**Zwei Schraube lösen**  
*Loosen two screws*



**Abheben und neu platzieren**  
*Lift and change position*



**Zwei Schrauben anziehen**  
*Fasten two screws*

### Vorteile auf einen Blick / Benefits at a glance:

- Sehr stabil, robuste Bauweise, dadurch hohe Präzision  
*Very stable, robust design allows high precision and heavy machining*
- Module nach oben abhebbar, kein Ausfahren nötig  
*Modules can be lifted up, no extension needed*
- Keine verschmutzbaren T-Nuten: Formschlüssig positioniert  
*No chip loading T-slots grooves: Positively positioned*
- Verzahnung nicht dem Werkstück ausgesetzt  
*The teeth are not exposed to the workpiece*
- Niederzug- und Linearspannung möglich  
*Pull-down and linear clamping possible*
- Spannkraft bis 7000 daN pro Modul  
*Clamping force up to 7000 daN per module*

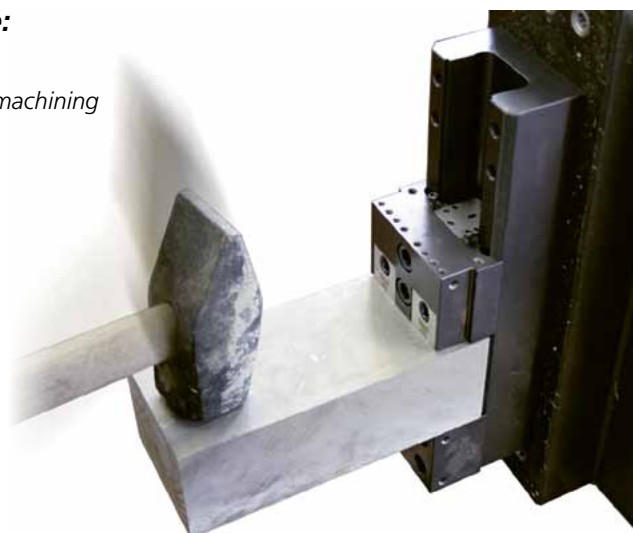

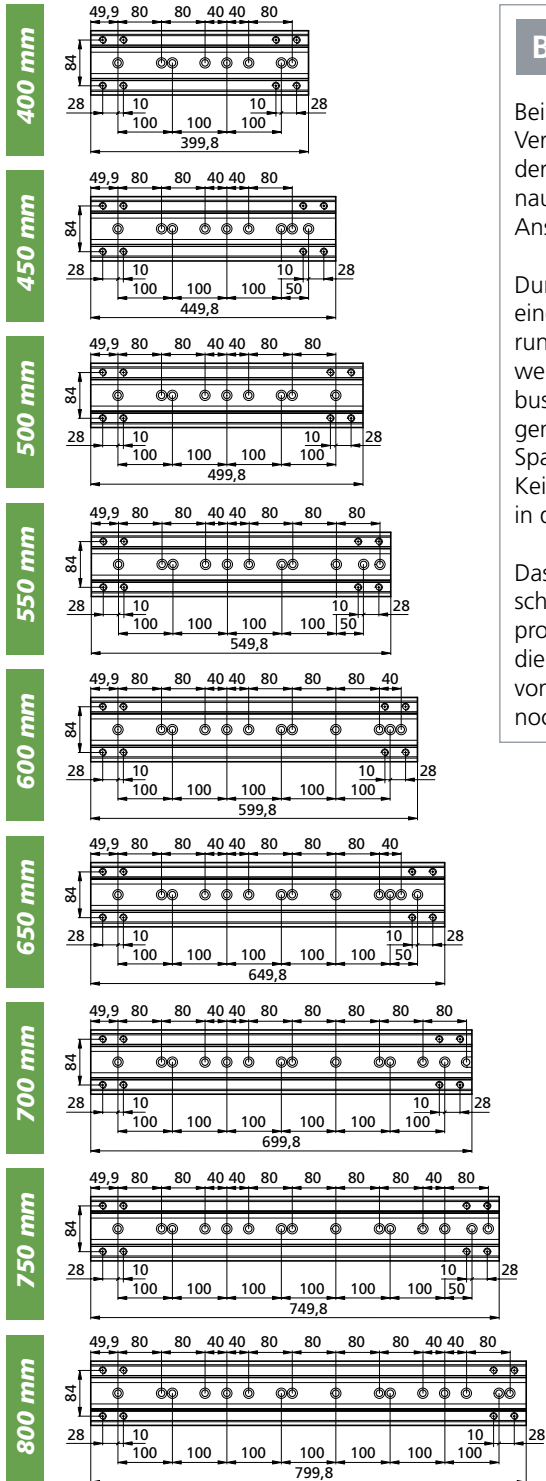

### Basisschiene / Base rail

Beim Apto Clamp ermöglicht eine Verzahnung mit 2 mm-Teilung auf der Basisschiene ein schnelles und genaues Positionieren der Spann- und Anschlagmodule.

*With the new Apto Clamp a serration of 2mm pitch on the base rail allows a rapid and accurate positioning of the modules.*

Durch gezielte elastische Deformation einer Lippe erfolgt eine spielfreie Paarung. Spann- und Bearbeitungskräfte werden einerseits an der ebenen, robusten Oberseite der Basisschiene aufgenommen, während andererseits das Spannmodul durch einen spreizenden Keil mit robustem Rundgewindeprofil in der Schiene verankert wird.

*The outstanding development is that through elastic deformation of a lip, the engagement between the modules and the base rail is without play. Clamping and machining forces are absorbed on the upper surface of the base rail whereas the vice module is fixed to the rail by an expandable anchor which engages the round serration inside the base rail.*

Das Einfügen zusätzlicher Module zwischen bestehenden Spannstellen ist problemlos möglich. Apto Clamp ist die konsequente Weiterentwicklung vom Power Clamp zur Bearbeitung noch grösserer Werkstücke.

*The insertion of additional vice modules can be accomplished without problems. Apto Clamp is the logical development of Power Clamp to handle even larger work pieces.*

Schnittzeichnung Sectional view of der Basisschiene the base rail

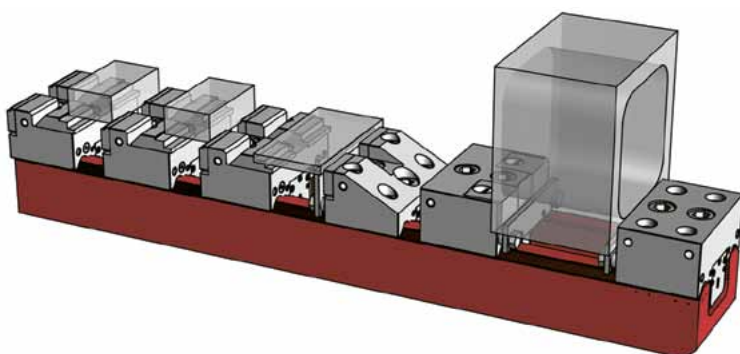
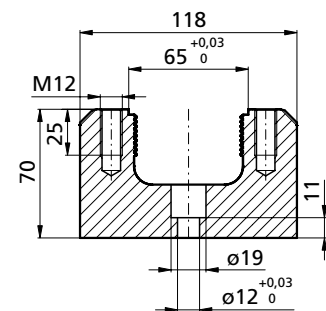





**Das Anschlagmodul / End modules**

In der Regel ist nur ein Anschlagmodul als „feste Backe“ erforderlich.  
*In general, only a stop module is required as a „fixed jaw.“*

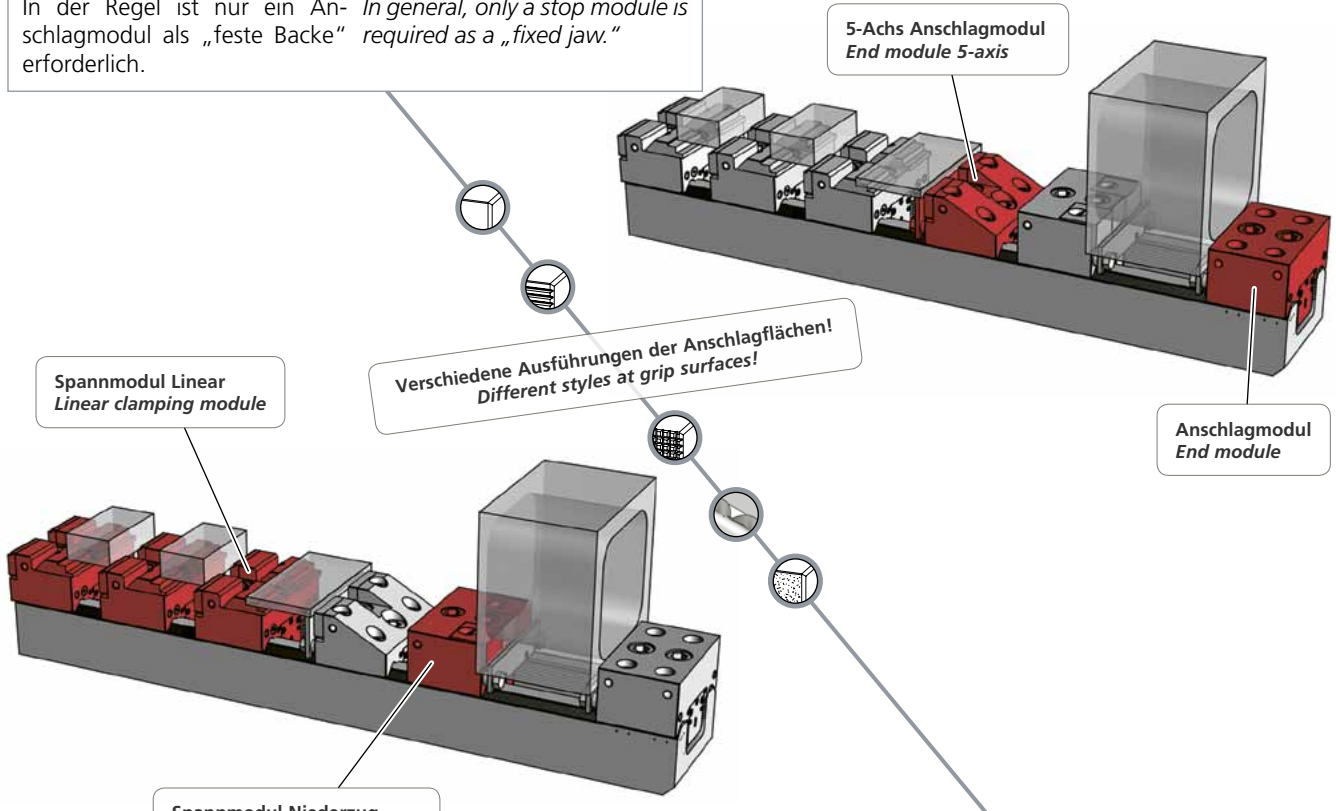

**Das Spannmodul / Clamp modules**

Die «beweglichen Backen» gibt es in zwei Ausführungen. Zum einen für das Niederzugspannsystem und zum anderen für das Linearspannsystem. Dabei dient das Spannmodul bei den Systemen wiederum als Anschlagmodul für die nächste Aufspannung.  
*Clamp modules have movable jaws (linear or pull down) in the front to clamp the part and on the back there is the datum face for the next work piece stop. Positioning step on the base rail is 2mm every.*





**Niederzugspannmodule**  
*Pull down clamp modules*

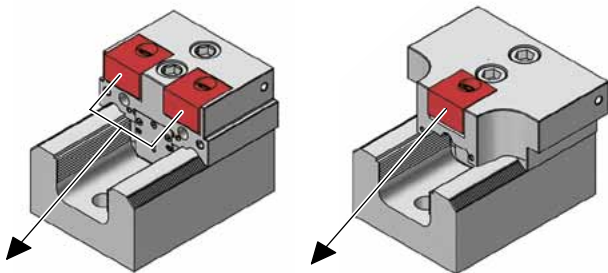

**Die Fakten beim Niederzugspannsystem**

Verstellbereich: 0- 3,8 mm  
 Spannkraft: Bis 7'000 daN

**Vorteile beim Niederzugspannsystem:**

- Höhere Haltekräfte
- Hohe Wiederholgenauigkeit
- Optimale Spannmethode für Kleinteile
- Mit Schnellwechselbacken
- Doppelspannsystem in einer Backe zum Spannen und Bearbeiten von zwei Kleinteilen

**Facts for pull down clamp modules**

Jaw range: 0- 3,8 mm  
 Clamping force: up to 7'000 daN

**Advantages pull down jaws:**

- Higher holding force
- With linear adaptable jaws
- Also with pull down jaws for the stop side available
- With adapter set can be changed to linear
- Also pull down jaws for datum face

**Linearspannmodule**  
*Linear clamp modules*

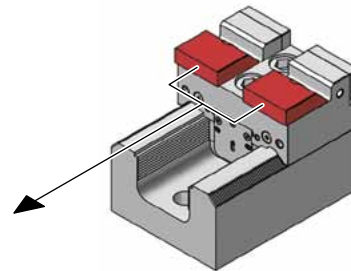

**Die Fakten beim Linearpannsystem**

Verstellbereich: 0- 5,0 mm  
 Spannkraft: Bis 3'200 daN

**Vorteile beim Linearpannsystem:**

- Spannstockähnliches Spannen
- Prozesssichere Positionierung der zweiten Aufspannung
- Gut geeignet für die Erstellung von individuellen Formbacken
- Sicherer Halt mit Prägetechnik

**Facts for linear clamp modules**

Jaw range: 0- 5,0 mm  
 Clamping force: up to 3'200 daN

**Advantages linear jaws:**

- Similar clamp as conventional vise
- Good for shaped jaws
- Secure clamped with direct stamping jaws
- Higher accuracy

**Universalnutenstein**  
*Universal nut*

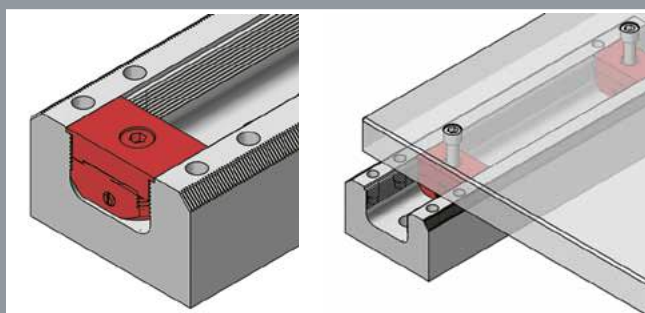

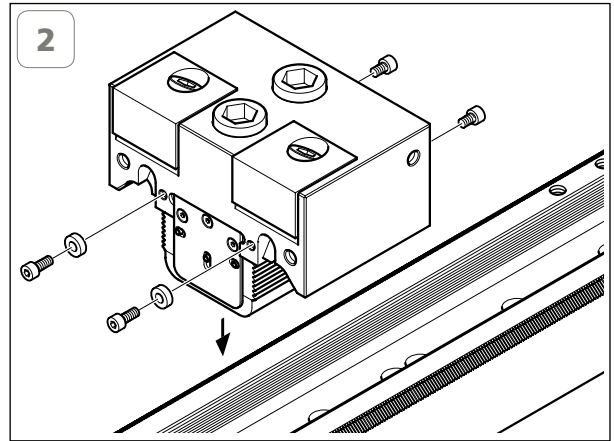
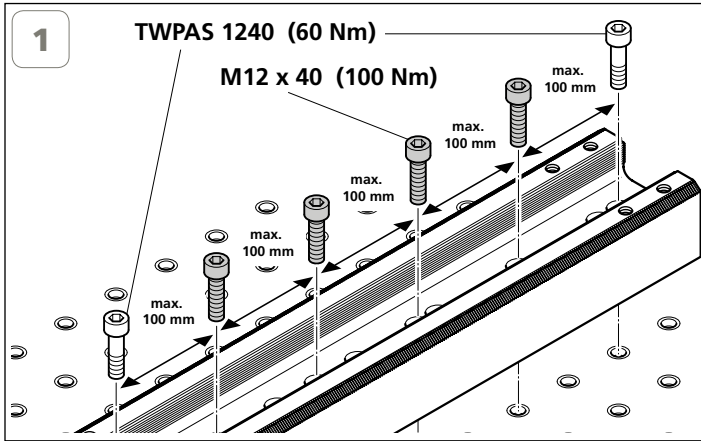

Ineinandergreifen der Verzahnung prüfen  
Check matching of the teeth

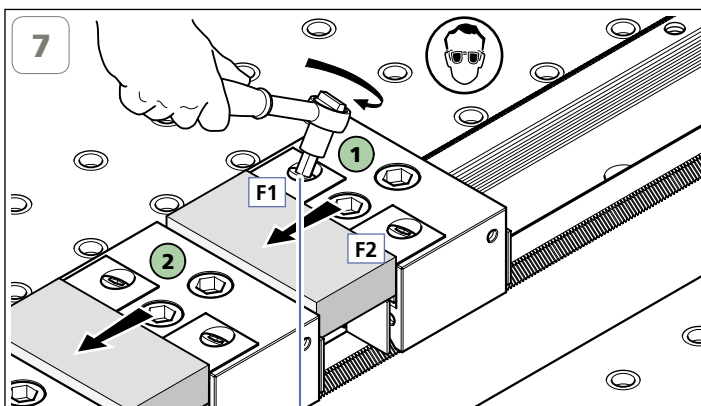
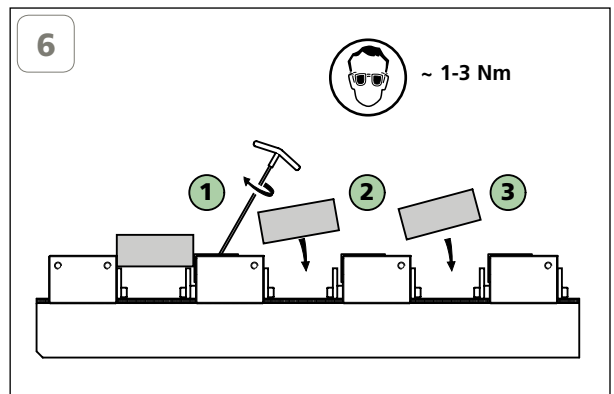
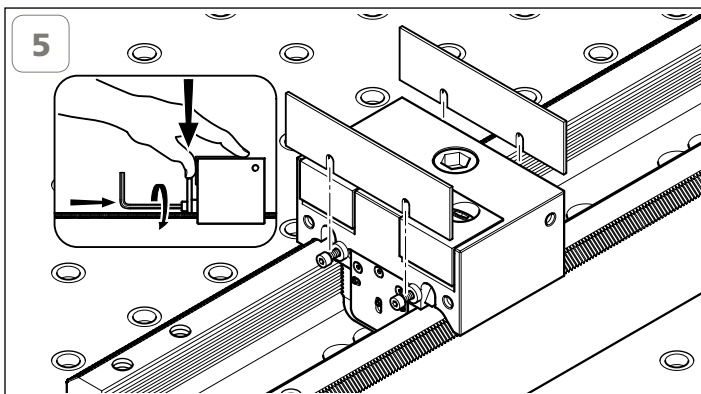
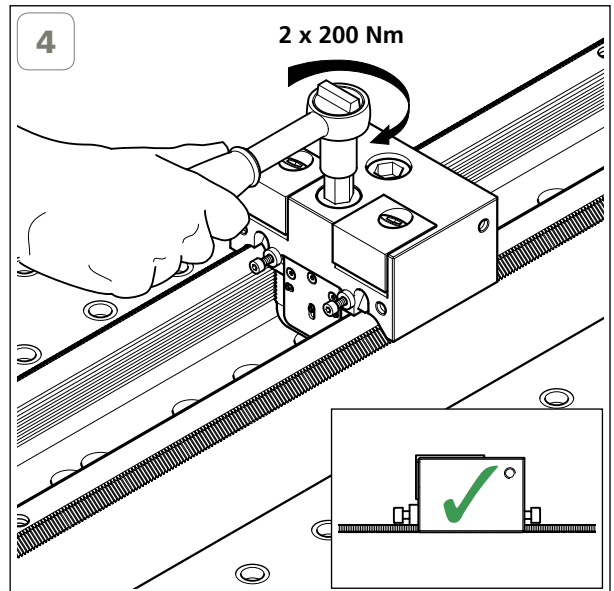
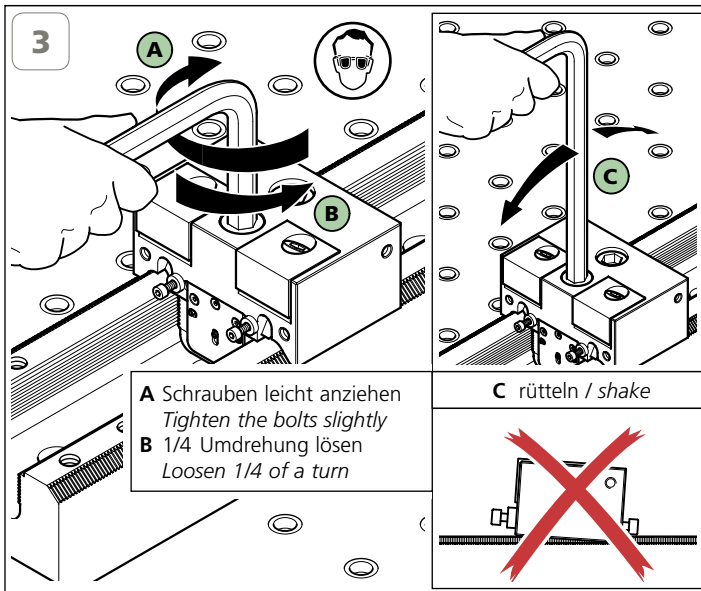

max. Drehmoment beachten  
Observe max. torque

Schraube Screw	Drehmoment Torque		Spannkraft (F1 & F2) Workholding force (F1 & F2)		
	Nm	(lb-ft)	~daN	~(lb)	~t
M10	10	7,4	= 1200	2'650	1,2
	20	14,8	= 2700	5'950	2,7
	30	22,2	= 4100	9'040	4,1
	40	29,5	= 5600	12'350	5,6
	50	37,0	= 7000	15'430	7,0

max. Nm





### ACHTUNG / CAUTION

**WICHTIG:** Die angegebenen Drehmomente sind die absoluten Maximalwerte. Über die Spannkraften gibt die untenstehende Tabelle Auskunft.

**IMPORTANT:** The torque numbers specified represent the absolute maximum. The table at the bottom of this page provides further information on the workholding forces.

Schraube Screw	Drehmoment Torque		Spannkraft (F1 & F2) Workholding force (F1 & F2)		
	Nm	(lb-ft)	~daN	~(lb)	~t
M10	10	7,4	= 1200	2'650	1,2
	20	14,8	= 2700	5'950	2,7
	30	22,2	= 4100	9'040	4,1
	40	29,5	= 5600	12'350	5,6
	50	37,0	= 7000	15'430	7,0

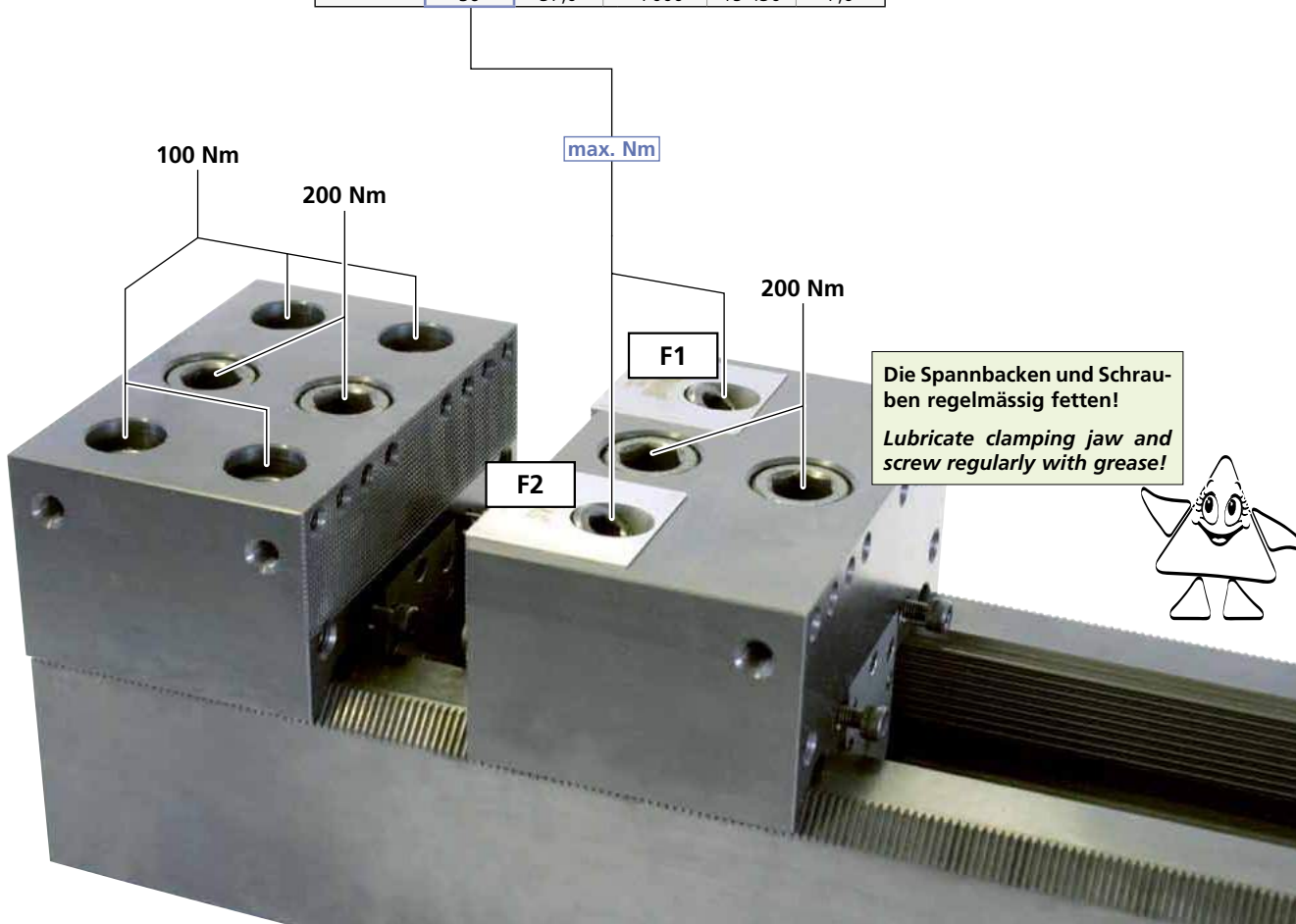

**WICHTIG:**

Vor dem Positionieren der Spannmodule für ein neues Werkstück ist die Spannbacke ganz zurück zu stellen, dies gewährleistet eine sichere Spannung (siehe Bild A)!

**IMPORTANT:**

Prior to setting up a new clamping module the clamping jaw of the vice module must be retracted all the way (see picture A)! This guarantees proper clamping of the new workpiece.

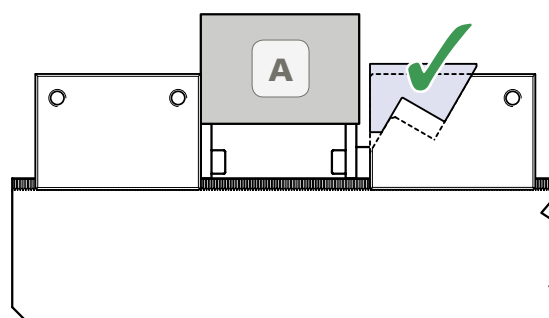
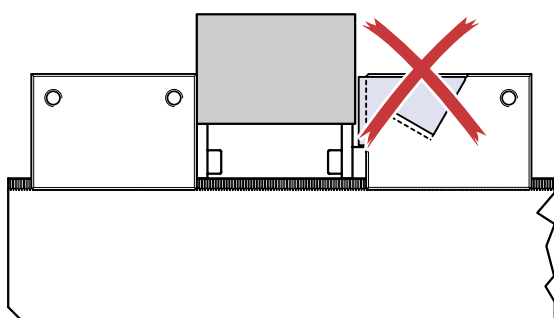

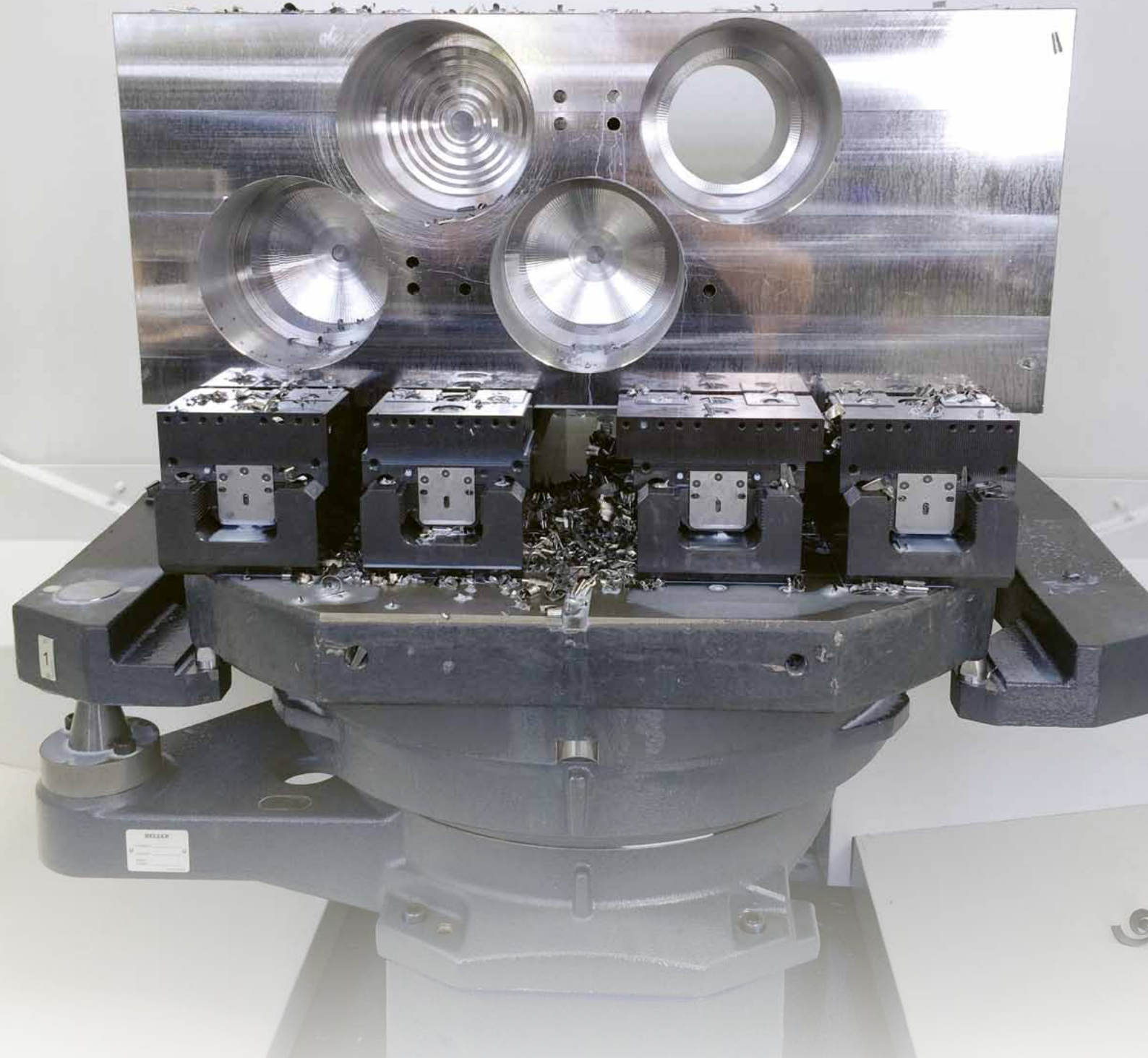

Material	42Cr Mo4
Bearbeitung mit Fräskopf	Ø 200
<i>Machining with milling head</i>	
Bohrer / Drills	Ø 124
Einspanntiefe / Clamping depth	24mm

**Apto Clamp in der Schwerzerspannung auf Heller 5-Achsen-Maschine**  
**Apto Clamp for heavy duty machining on a 5-axis machine**



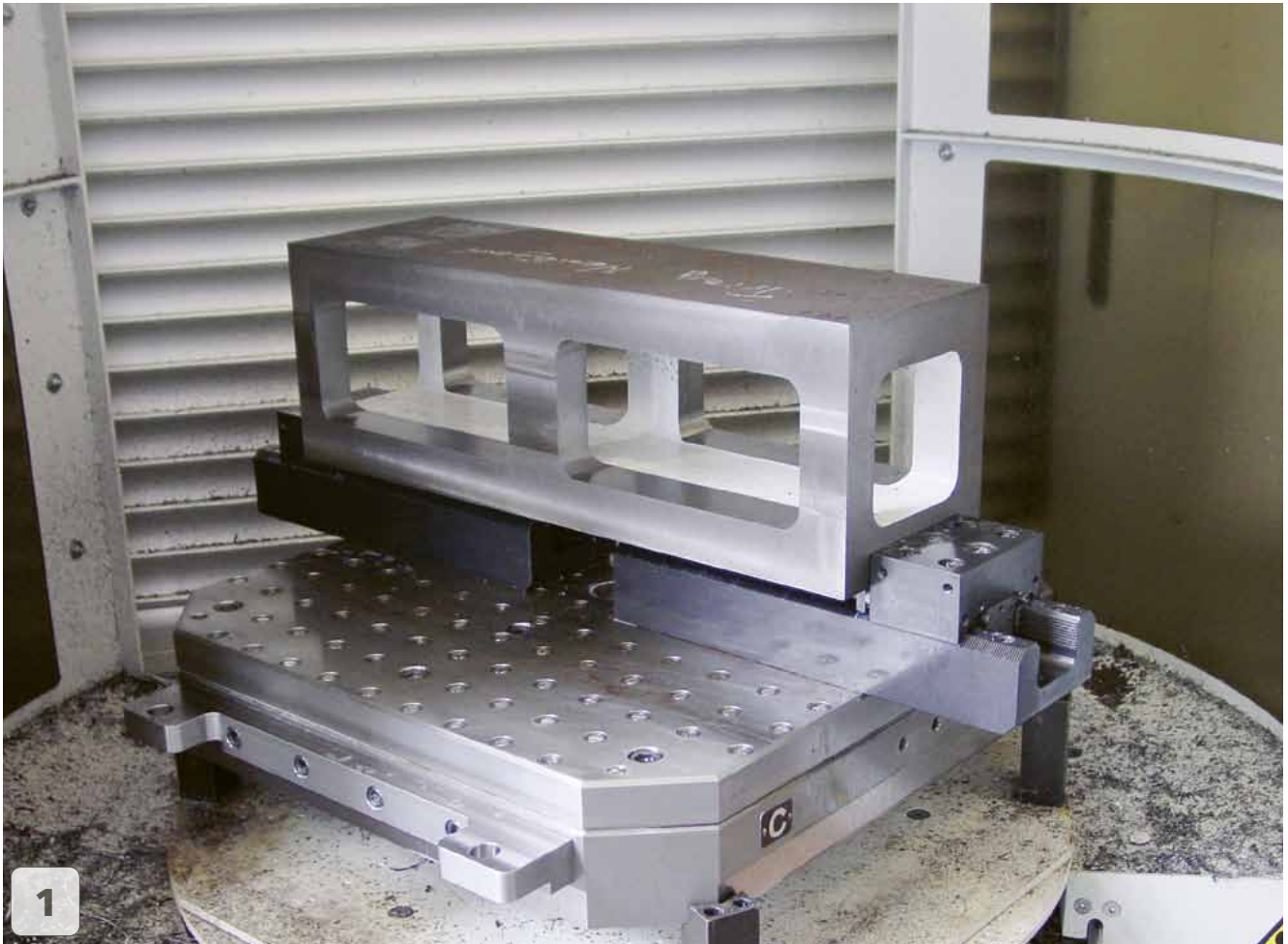



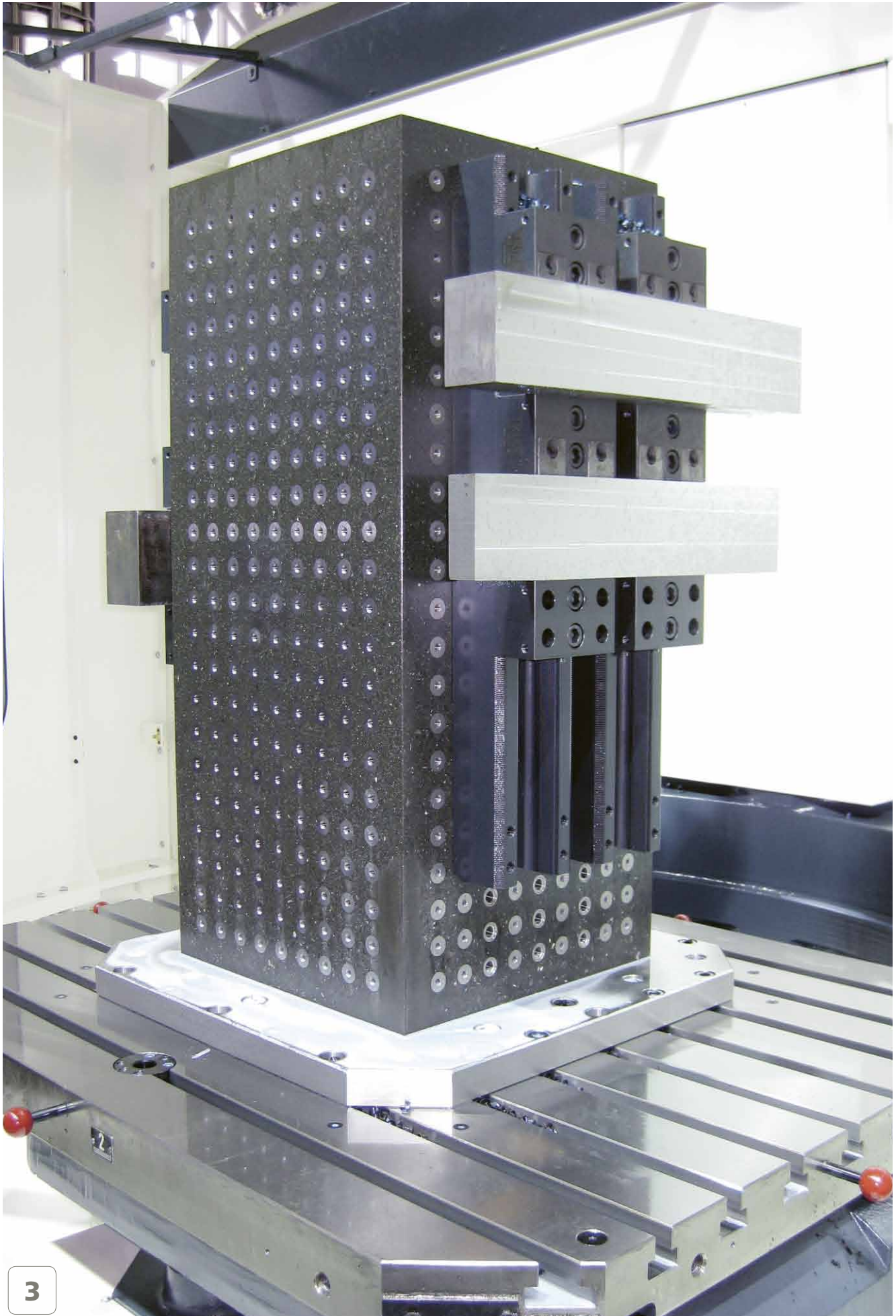

3

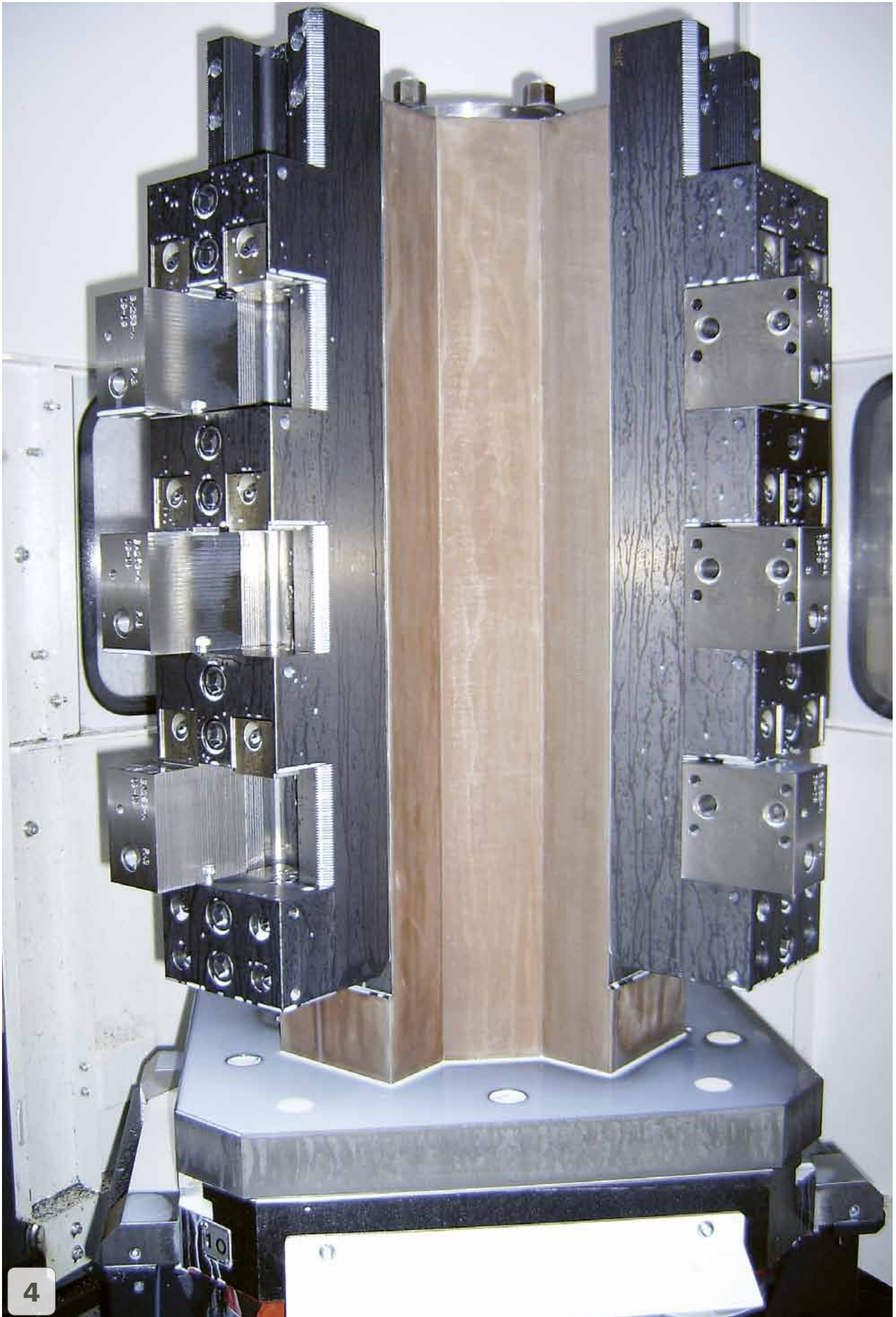



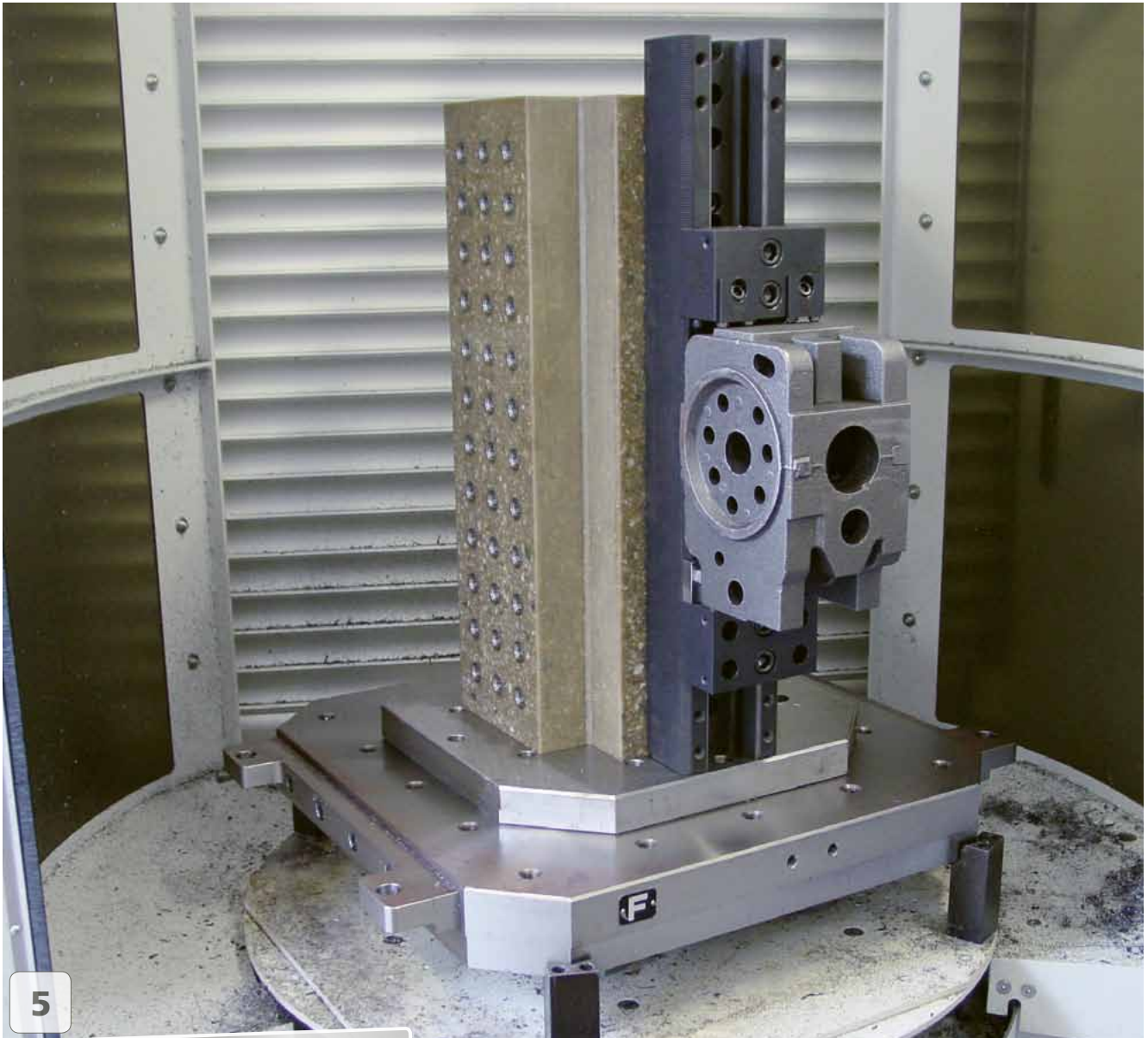

5

**VERTICAL** (3-4 ACHSEN/AXES)

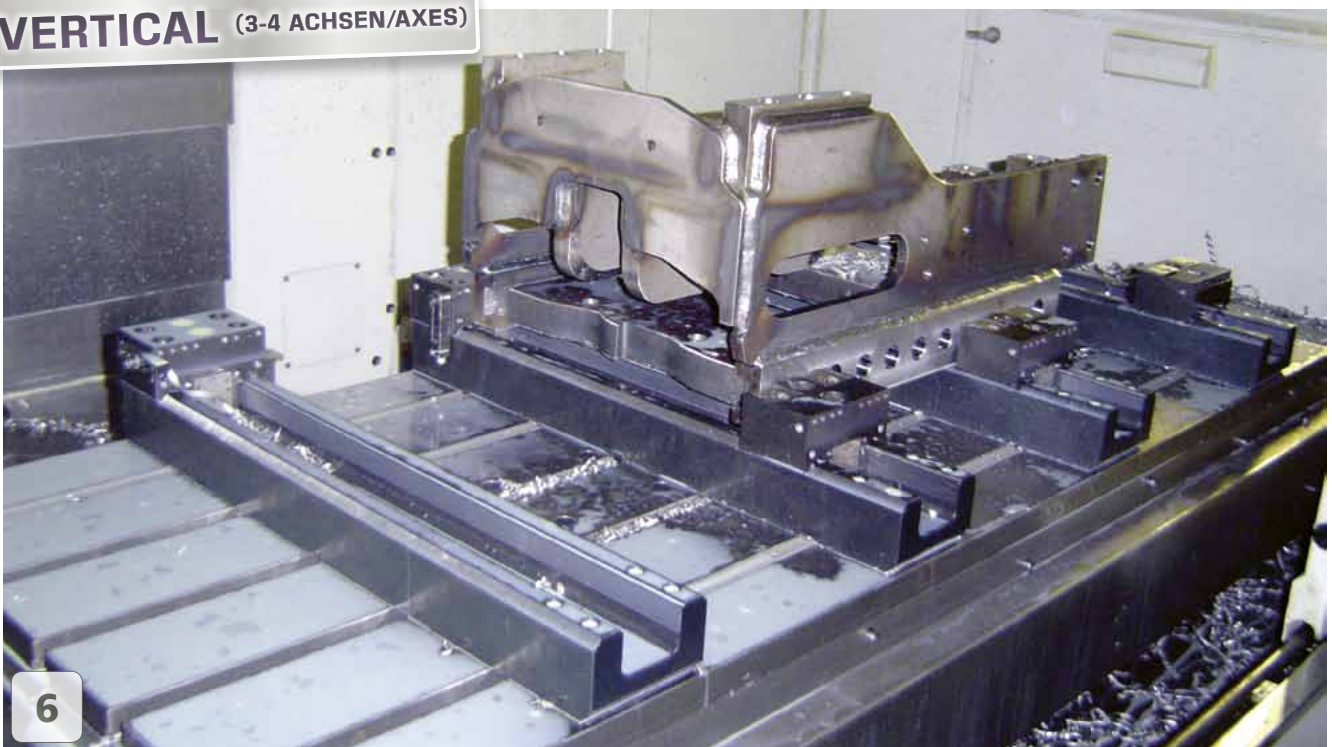

6



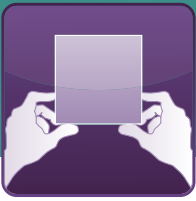

## 5axes aptoCLAMP

Es gibt zusätzlich Apto Clamp Module in angeschrägter Ausführung. Damit kann ein optimaler Zugang zum Werkstück bei der 5-Achsenmaschine gewährleistet werden. Die Spannmodule produzieren bis zu 7000daN (7 Tonnen) Spannkraft und sind für die Schwerzerspannung empfohlen.

*We offer Apto Clamp modules in slanted version. That ensures an optimal access to the workpieces on 5-axis machines. The clamping modules produce up to 7000daN (7 tons) clamping force and are recommended for heavy roughing workholding.*

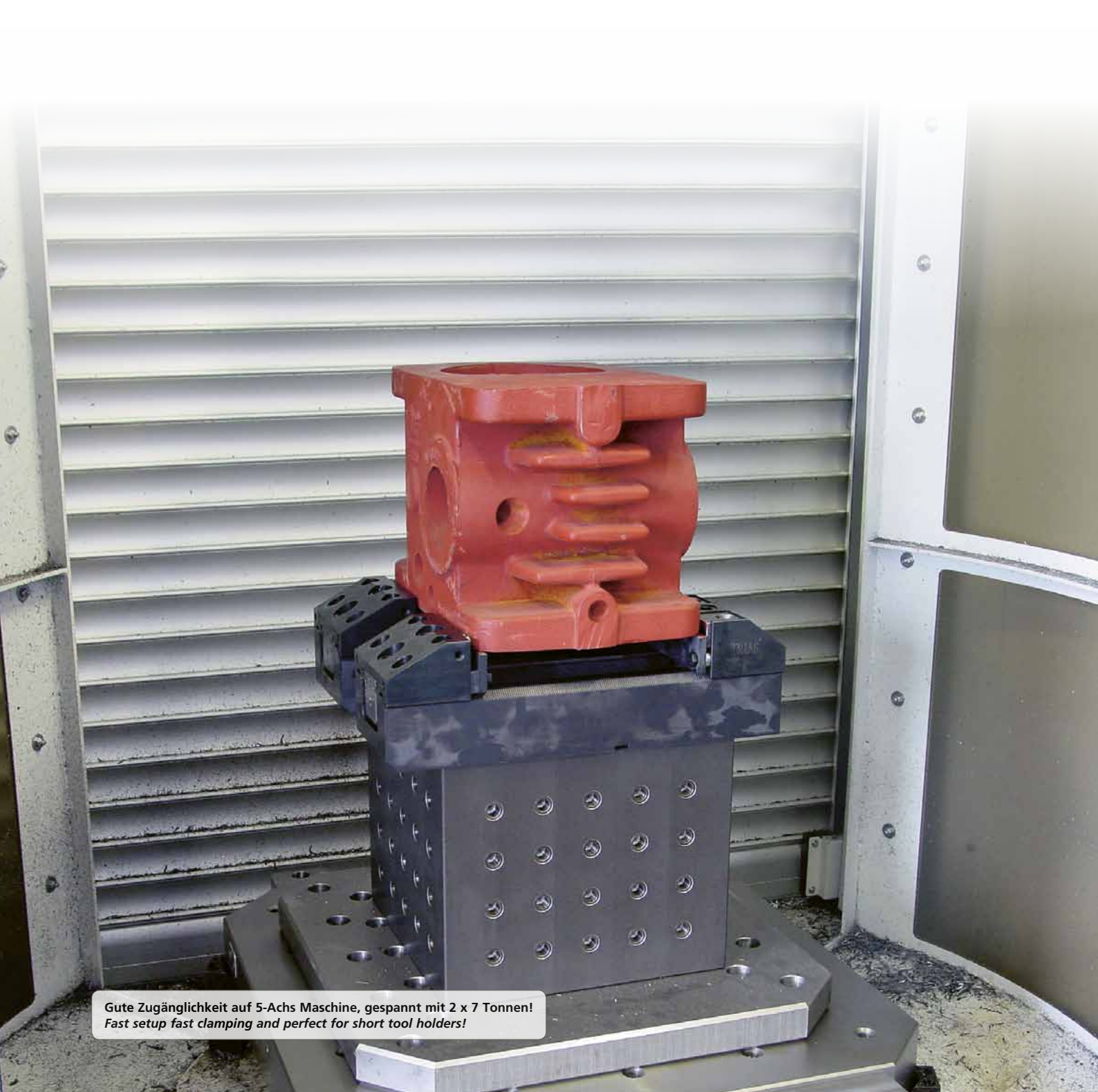

**Gute Zugänglichkeit auf 5-Achs Maschine, gespannt mit 2 x 7 Tonnen!  
Fast setup fast clamping and perfect for short tool holders!**

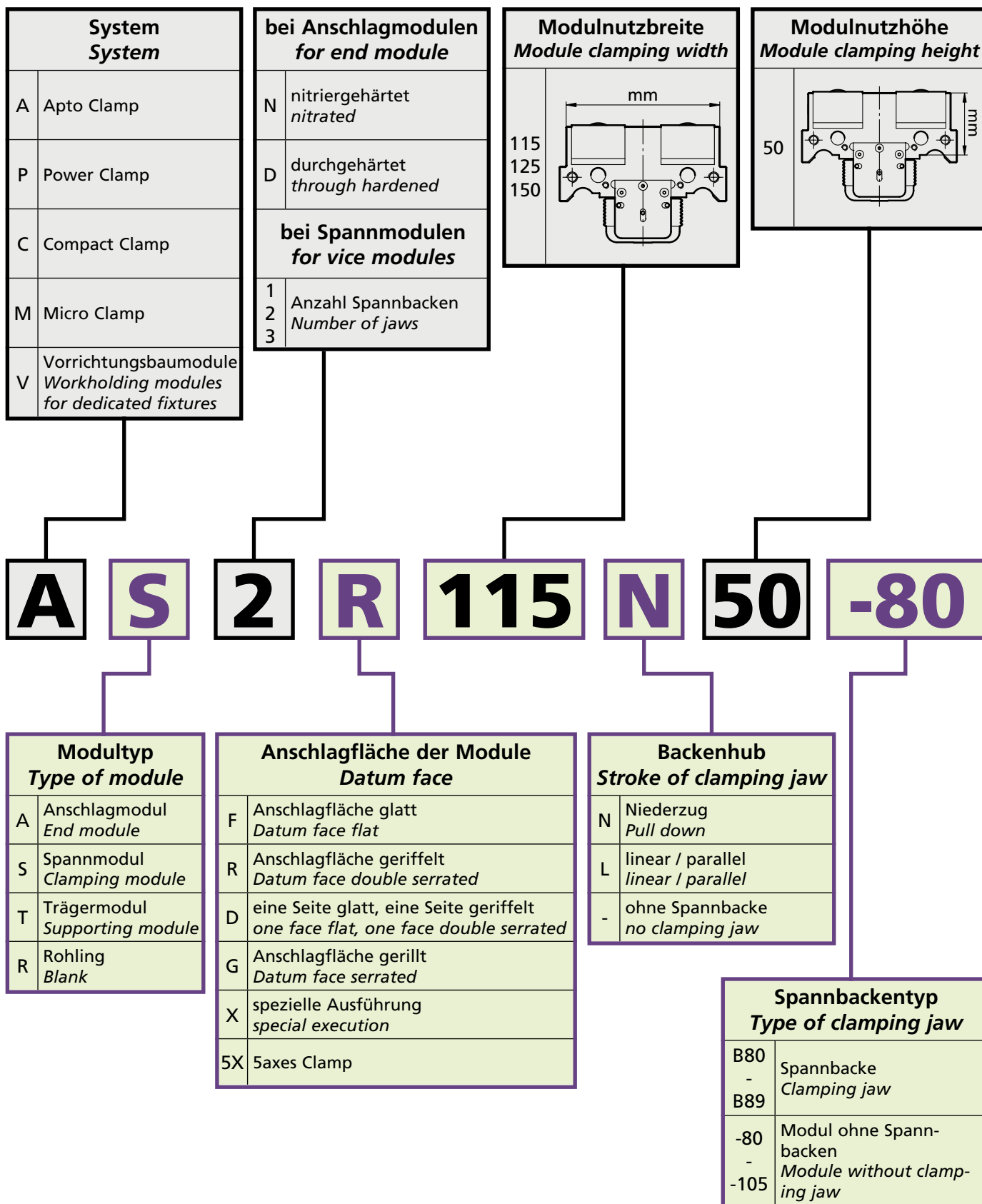



**ACB4050400** kg ~18

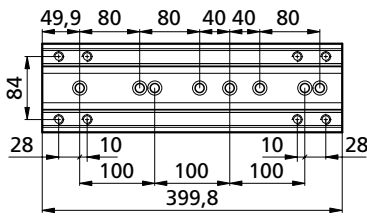

**ACB4050700** kg ~31

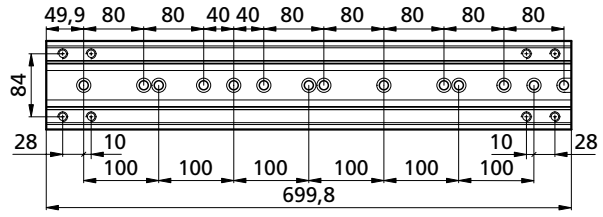

**ACB4050450** kg ~20

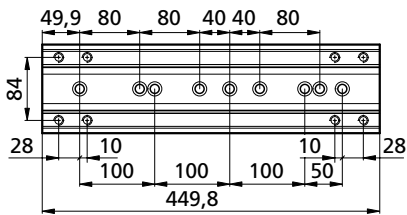

**ACB4050750** kg ~33

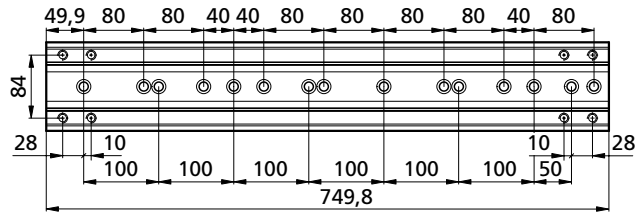

**ACB4050500** kg ~22

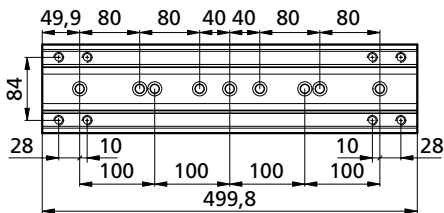

**ACB4050800** kg ~35

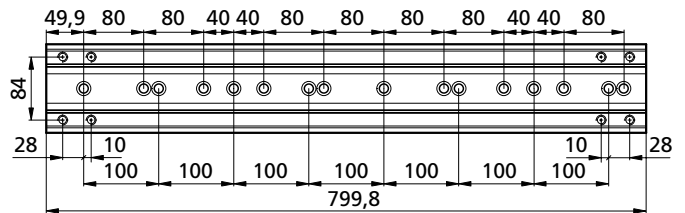

**ACB4050550** kg ~24

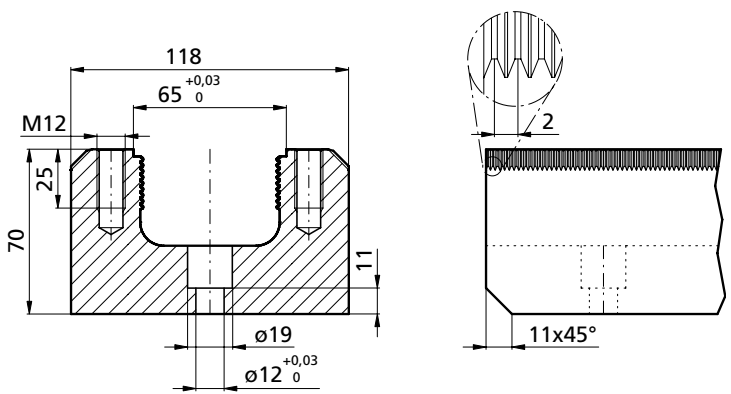
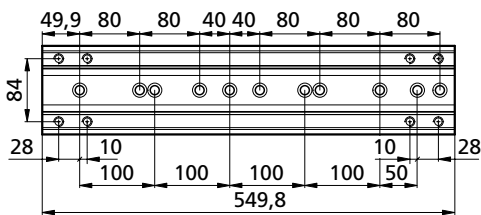

**ACB4050600** kg ~26

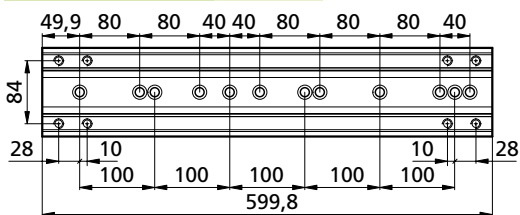

**ACB4050650** kg ~29

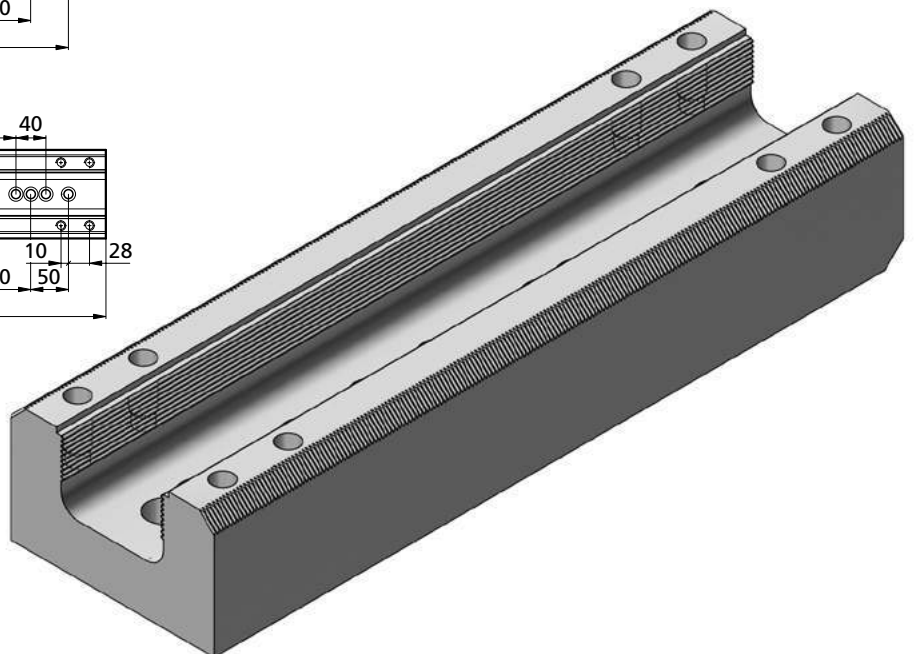
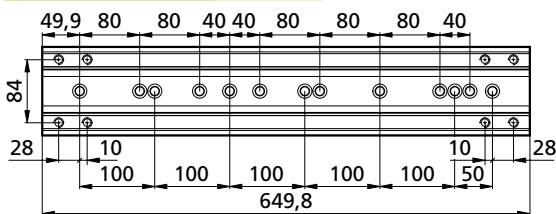



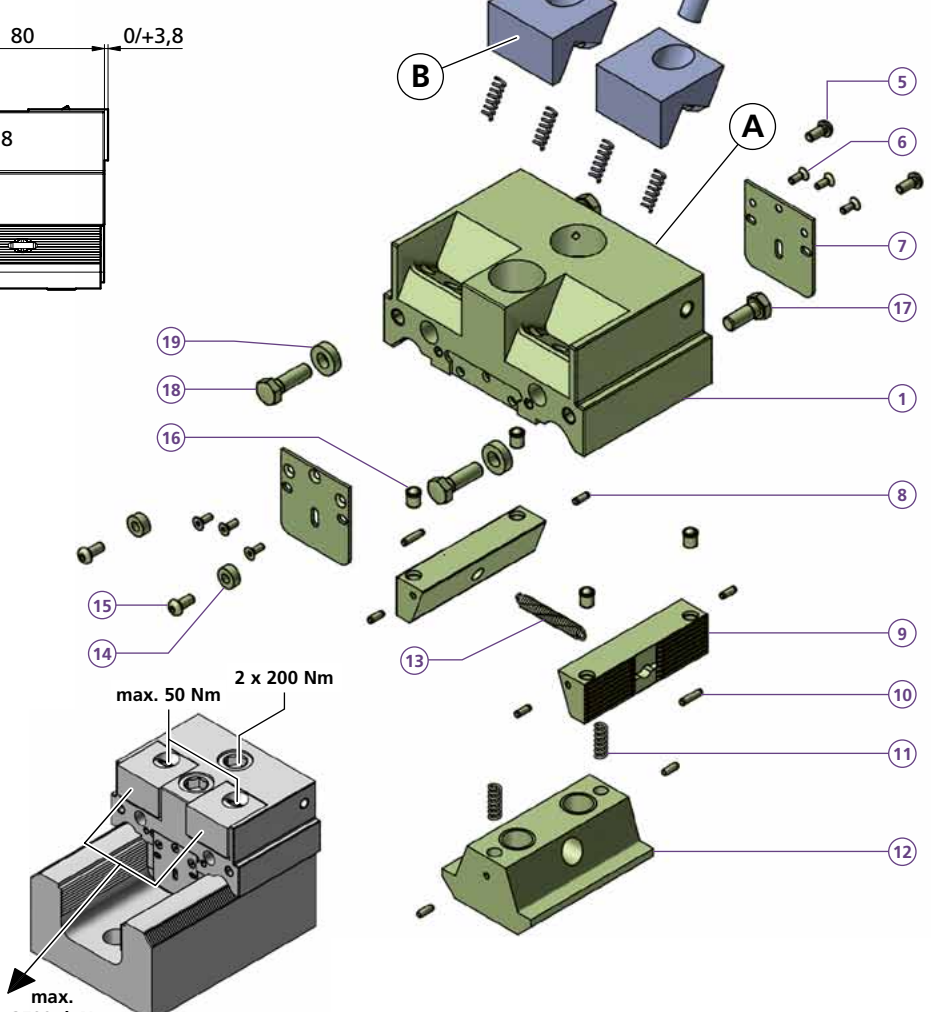
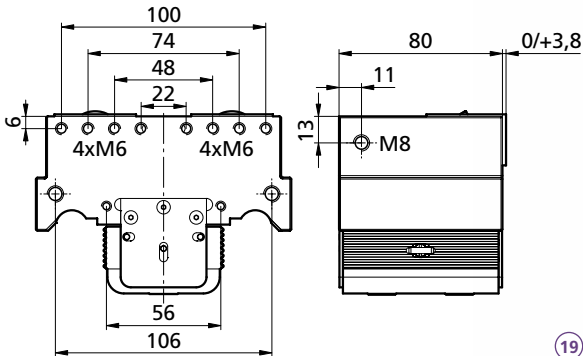
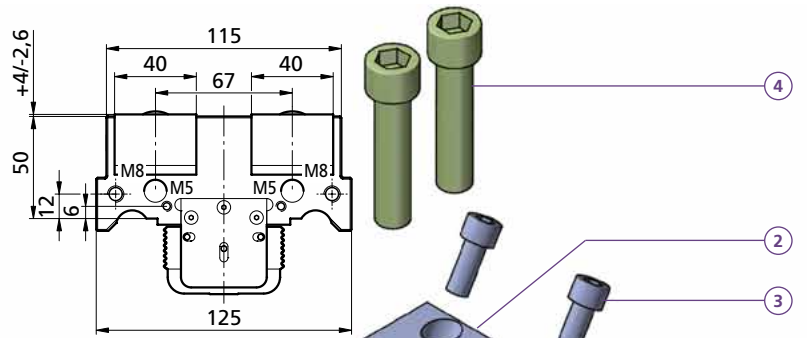
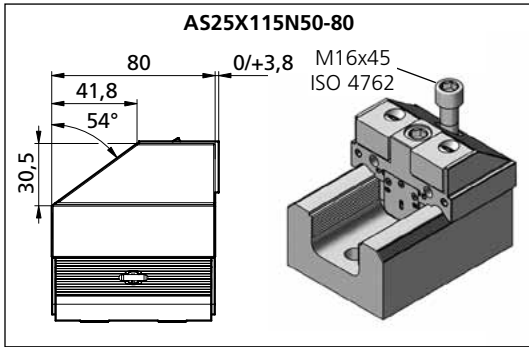

- AS25X115N50-80**
- 1x TF140678
  - 1x M16X45ISO4762
  - 1x M16X70ISO4762
  - 2x M8X20ISO4017
  - 2x ACD005
  - kg ~4,3
- AS2F115N50-80**
- 1x TF140676
- AS2R115N50-80**
- 1x TF140677
  - 2x
  - 2x M10X25ISO4762
  - 2x M16X70ISO4762
  - 2x M5X10ISO7380-1
  - 6x M3X6DIN7991
  - 2x ACBL4243
  - 6x Ø 3x8 VSM 12785
  - 2x ACSP7620
  - 2x Ø 3h 8x12 ISO 2338
  - 6x FED0618
  - 1x ACSK7632M16
  - 1x FED Ø 5,5x39
  - 2x PCD005
  - 2x M5X14ISO7380-1
  - 4x Ø 6-Niro SM1275-3
  - 2x M8X16ISO4017
  - 2x M8X20ISO4017
  - 2x ACD005
  - kg ~4,8

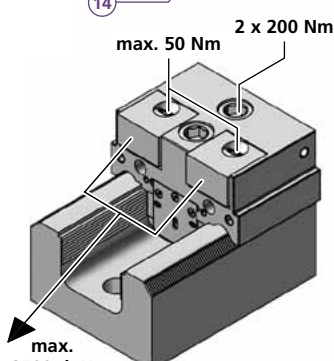

max. 3500 daN

Bestellbeispiel / Ordering example: 1x AS2R115N50-80 & 2x B80

	B80	B80N	B81	B82	B82L33	B82HM	B83	B84	B89F	B89R
C	40	40	40	40	40	40	40	40	40	40
H	25	25	25	25	25	25	25	25	25	25
L	22	22	22	22,2	33	22,2	22	26,3	29	29
D	11	11	11	11	11	11	11	11	11	11
ø	15	15	15	15	15	15	15	15	15	15
i	56HRC	HV700 x0,2mm	56HRC	*	*	56HRC	HV700 x0,2mm	*	HV700 x0,2mm	HV700 x0,2mm
kg	~0,2	~0,2	~0,2	~0,2	~0,28	~0,2	~0,2	~0,2	~0,24	~0,24

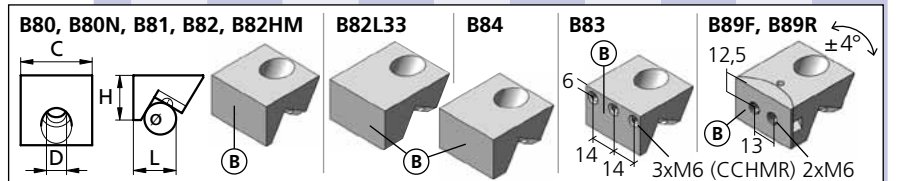

\* = weich / soft

HM = Hartmetallbeschichtet / Carbide coated

Separat bestellen / Separate order

# AS2R/F125N50-80 AS25X125N50-80

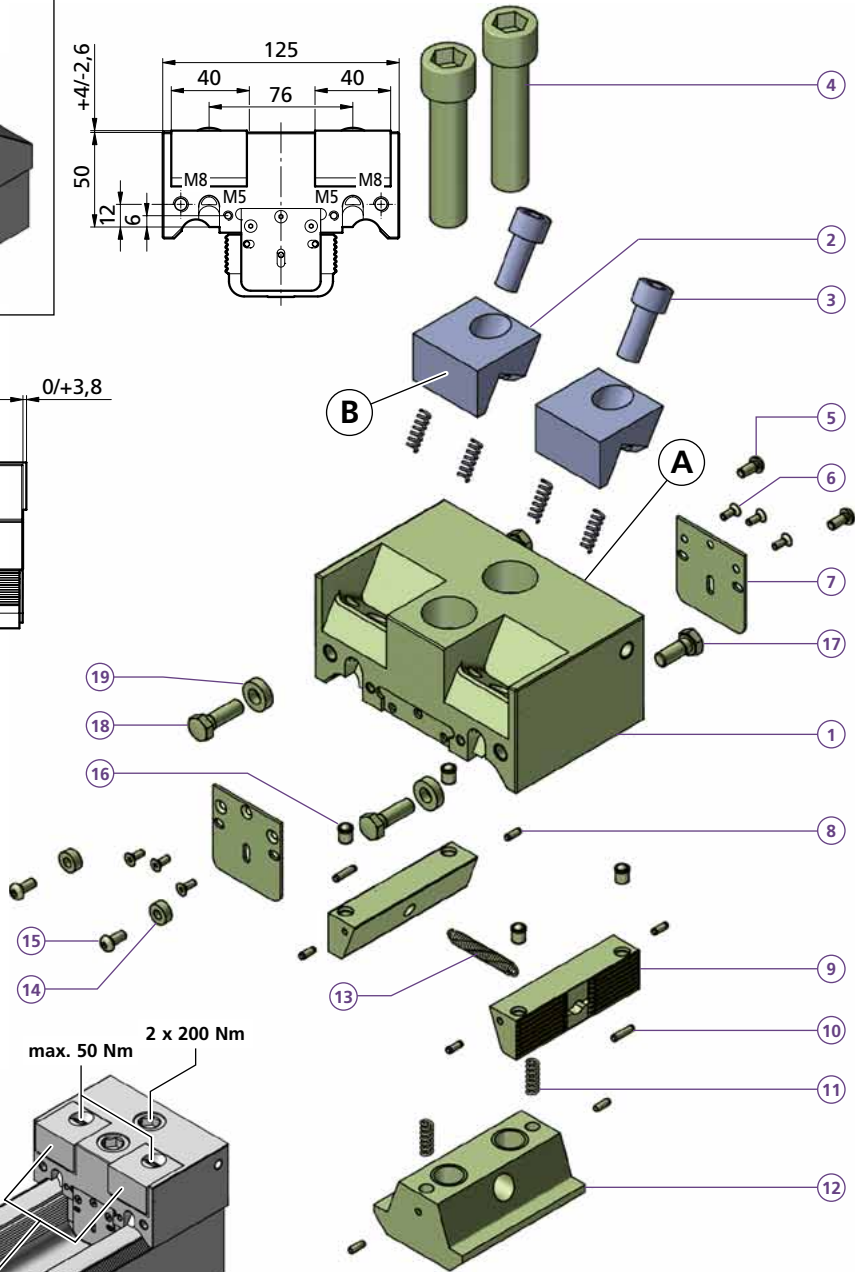
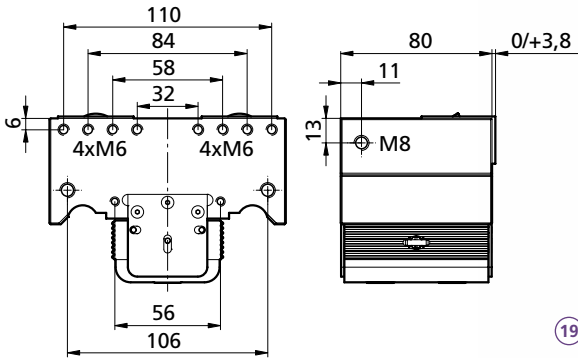
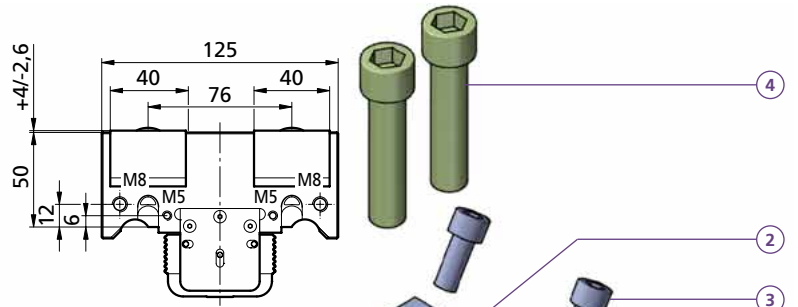
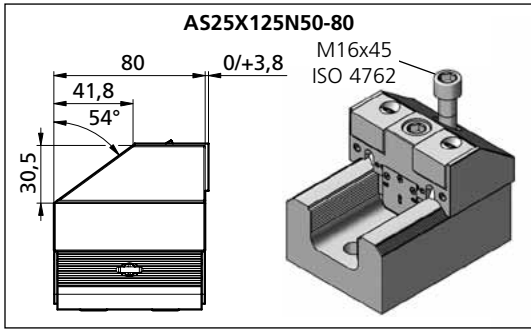

- AS25X125N50-80**
- 1 1x TF140682
  - 4 1x M16X45ISO4762
  - 18 2x M8X20ISO4017
  - 19 2x ACD005
  - kg ~4,3
- AS2F125N50-80**
- 1 1x TF140680
- AS2R125N50-80**
- 1 1x TF140681
  - 2 2x
  - 3 2x M10X25ISO4762
  - 4 2x M16X70ISO4762
  - 5 2x M5X10ISO7380-1
  - 6 6x M3X6DIN7991
  - 7 2x ACBL4243
  - 8 6x Ø 3x8 BN 879
  - 9 2x ACSP7620
  - 10 2x Ø 3h 8x12 ISO 2338
  - 11 6x FED0618
  - 12 1x ACSK7632M16
  - 13 1x FED Ø 5,5x39
  - 14 2x PCD005
  - 15 2x M5X14ISO7380-1
  - 16 4x Ø 6-Niro SM1275-3
  - 17 2x M8X16ISO4017
  - 18 2x M8X20ISO4017
  - 19 2x ACD005
  - kg ~4,9

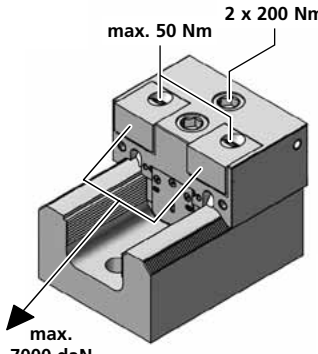

max. 7000 daN

Bestellbeispiel / Ordering example: 1x AS2R125N50-80 & 2x B80

	B80	B80N	B81	B82	B82L33	B82HM	B83	B84	B89F	B89R
C	40	40	40	40	40	40	40	40	40	40
H	25	25	25	25	25	25	25	25	25	25
L	22	22	22	22,2	33	22,2	22	26,3	29	29
D	11	11	11	11	11	11	11	11	11	11
ø	15	15	15	15	15	15	15	15	15	15
i	56HRC	HV700	56HRC	*	*	56HRC	HV700	*	HV700	HV700
kg	~0,2	~0,2	~0,2	~0,2	~0,28	~0,2	~0,2	~0,2	~0,24	~0,24

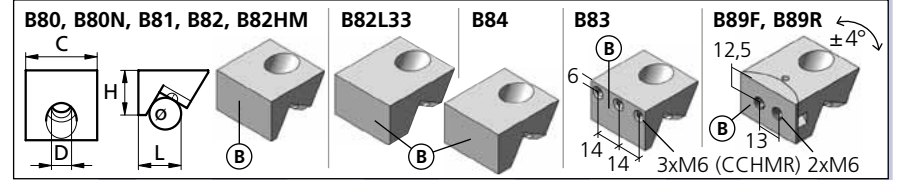

HM = Hartmetallbeschichtet / Carbide coated

Separat bestellen / Separate order

# AS2R/F150N50-80 AS25X150N50-80

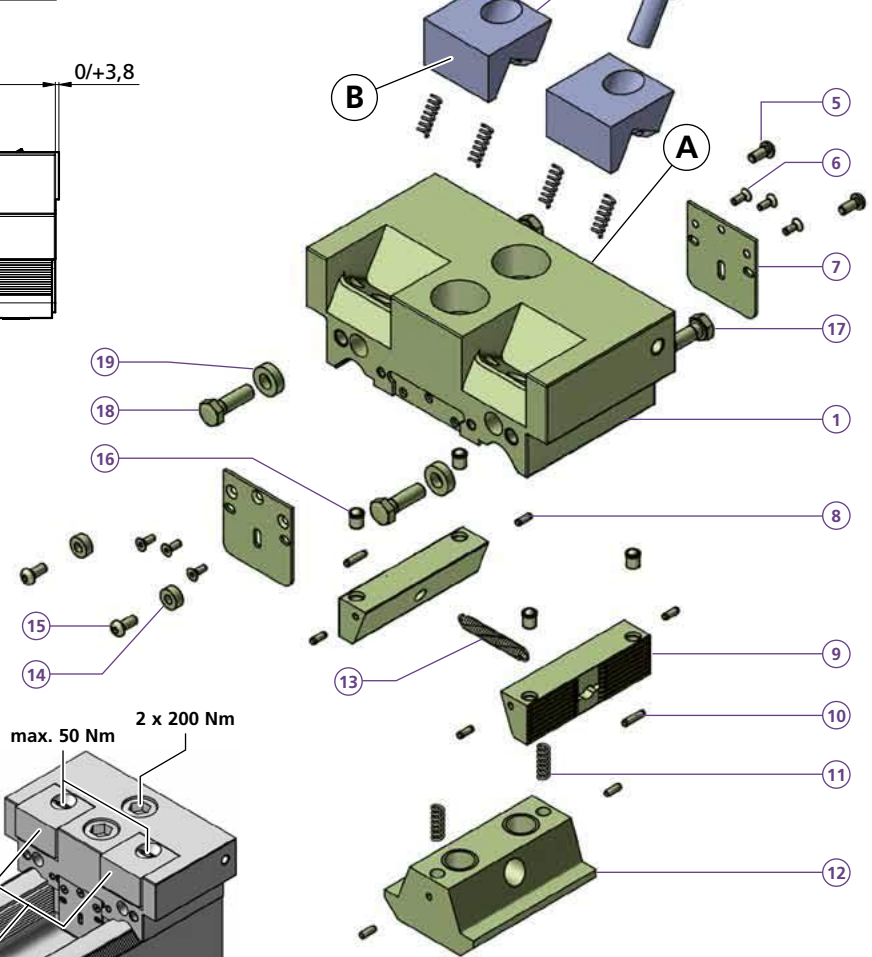
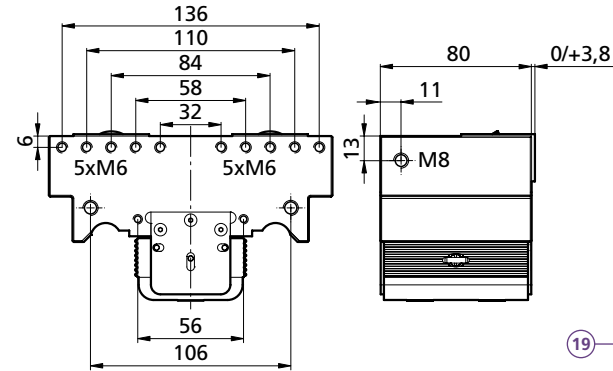
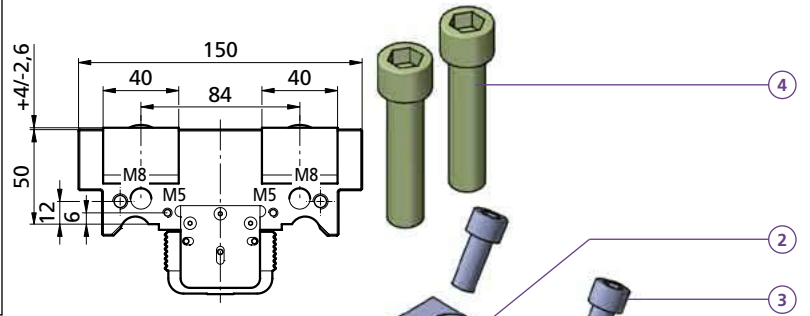
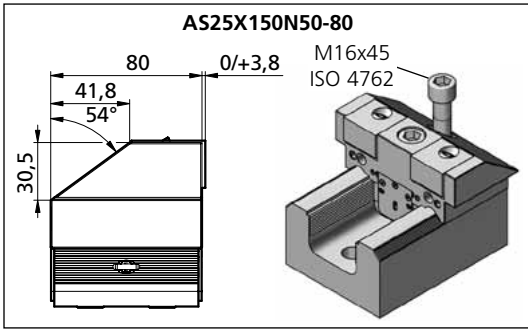

- AS25X150N50-80**
- 1 1x TF140687
  - 4 1x M16X45ISO4762
  - 18 2x M8X20ISO4017
  - 19 2x ACD005
- kg ~4,7
- AS2F150N50-80**
- 1 1x TF140685
- AS2R150N50-80**
- 1 1x TF140686
  - 2 2x
  - 3 2x M10X25ISO4762
  - 4 2x M16X70ISO4762
  - 5 2x M5X10ISO7380-1
  - 6 6x M3X6DIN7991
  - 7 2x ACBL4243
  - 8 6x Ø 3x8 VSM 12785
  - 9 2x ACSP7620
  - 10 2x Ø 3h 8x12 ISO 2338
  - 11 6x FED0618
  - 12 1x ACSK7632M16
  - 13 1x FED Ø 5,5x39
  - 14 2x PCD005
  - 15 2x M5X14ISO7380-1
  - 16 4x Ø 6-Niro SM1275-3
  - 17 2x M8X16ISO4017
  - 18 2x M8X20ISO4017
  - 19 2x ACD005
- kg ~5,4

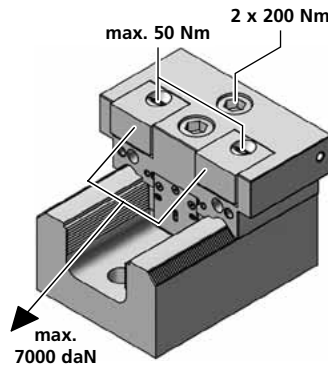

max. 7000 daN

Bestellbeispiel / Ordering example: 1x AS2R150N50-80 & 2x B80

	B80	B80N	B81	B82	B82L33	B82HM	B83	B84	B89F	B89R
C	40	40	40	40	40	40	40	40	40	40
H	25	25	25	25	25	25	25	25	25	25
L	22	22	22	22,2	33	22,2	22	26,3	29	29
D	11	11	11	11	11	11	11	11	11	11
ø	15	15	15	15	15	15	15	15	15	15
i	56HRC	HV700 x0,2mm	56HRC	*	*	56HRC	HV700 x0,2mm	*	HV700 x0,2mm	HV700 x0,2mm
kg	~0,2	~0,2	~0,2	~0,2	~0,28	~0,2	~0,2	~0,2	~0,24	~0,24

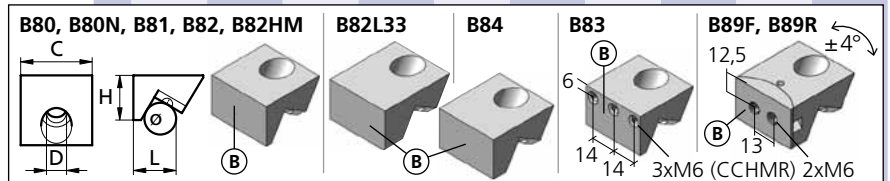

\* = weich / soft

HM = Hartmetallbeschichtet / Carbide coated

Separat bestellen / Separate order



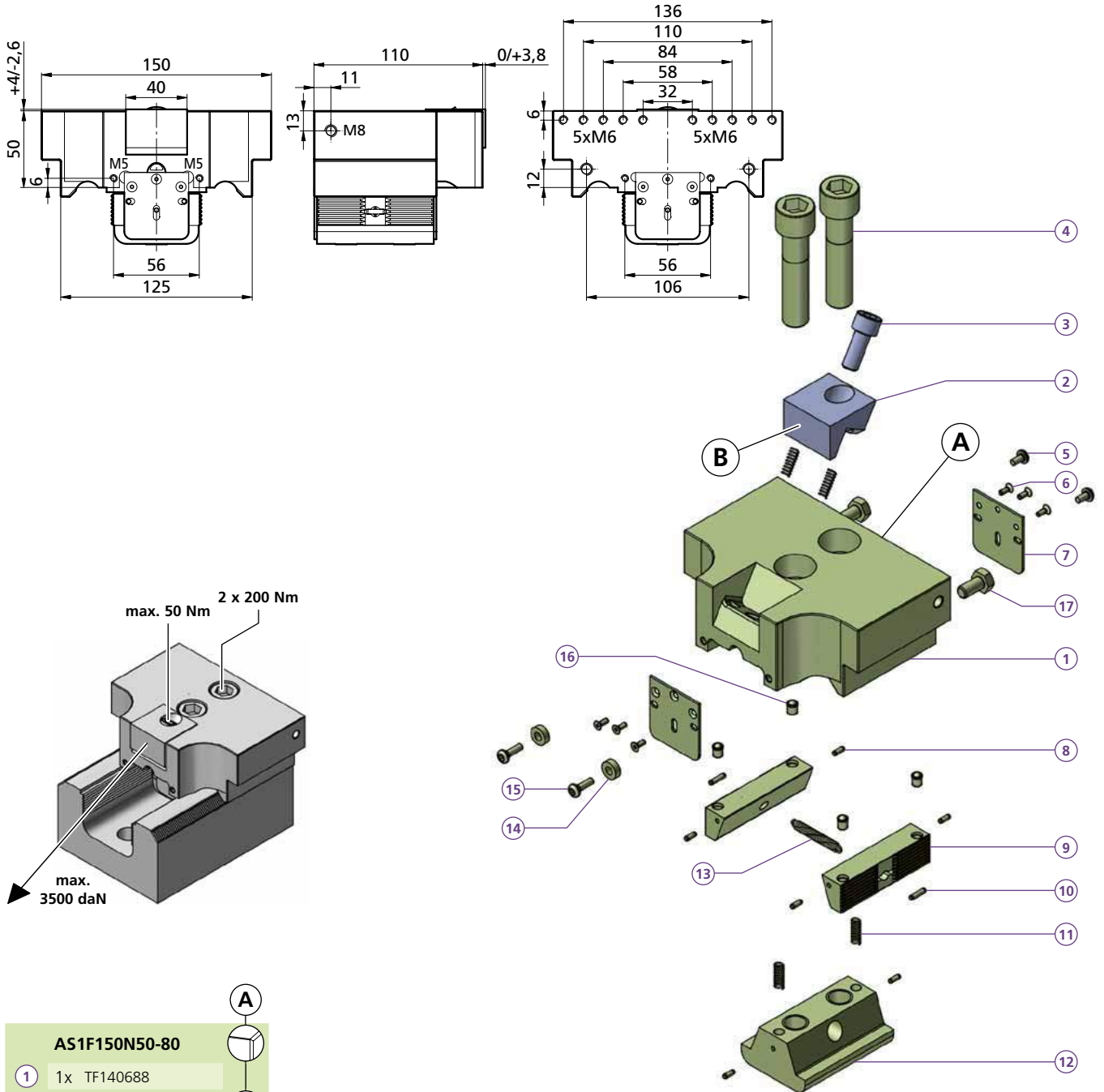

- AS1F150N50-80**
- 1x TF140688
- AS1R150N50-80**
- 1x TF140689
- 2x
- 1x **M10X25ISO4762**
- 2x **M16X70ISO4762**
- 2x **M5X10ISO7380-1**
- 6x M3X6DIN7991
- 2x ACBL4243
- 6x Ø 3x8 VSM 12785
- 2x ACSP7620
- 2x Ø 3h 8x12 ISO 2338
- 4x **FED0618**
- 1x ACSK7632M16
- 1x FED Ø 5,5x39
- 2x **PCD005**
- 2x **M5X14ISO7380-1**
- 4x Ø 6-Niro SM1275-3
- 2x M8X16ISO4017
- kg ~6,6

Bestellbeispiel / Ordering example: 1x AS1R150N50-80 & 1x B80

	B80	B80N	B81	B82	B82L33	B82HM	B83	B84	B89F	B89R
C	40	40	40	40	40	40	40	40	40	40
H	25	25	25	25	25	25	25	25	25	25
L	22	22	22	22,2	33	22,2	22	26,3	29	29
D	11	11	11	11	11	11	11	11	11	11
ø	15	15	15	15	15	15	15	15	15	15
i	56HRC	HV700 x0,2mm	56HRC	*	*	56HRC	HV700 x0,2mm	*	HV700 x0,2mm	HV700 x0,2mm
kg	~0,2	~0,2	~0,2	~0,2	~0,28	~0,2	~0,2	~0,2	~0,24	~0,24

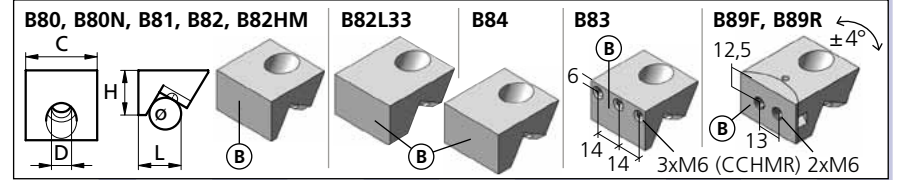

# AS2X125L50-105 AS25X125L50-105

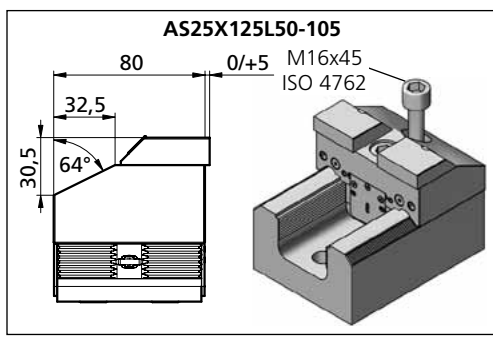
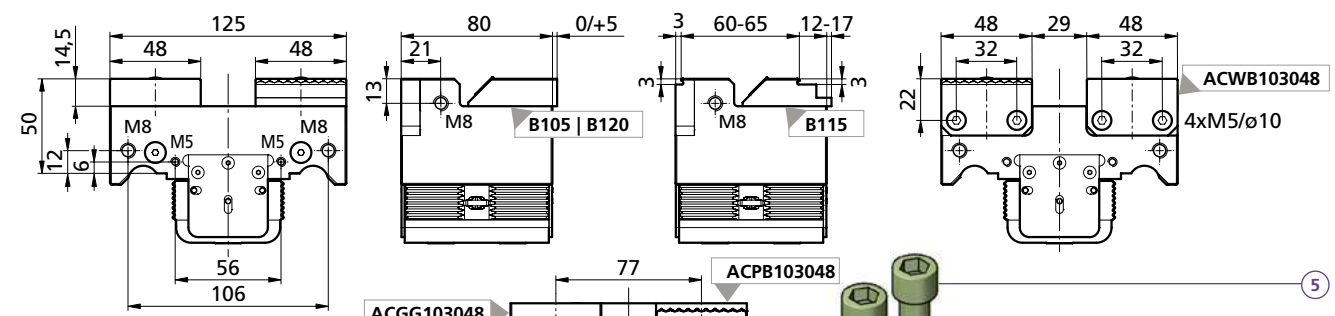

- |   |                            |
|---|----------------------------|
|  | <b>AS25X125L50-105</b>     |
| 1   | 1x TF140683                |
| 4   | 1x <b>M16X45ISO4762</b>    |
| 19  | 1x <b>M16X55ISO4762</b>    |
| 20  | 2x M8X20ISO4017            |
| 20  | 2x <b>ACD005</b>           |
| kg  | ~4,3                       |
|   | <b>AS2X125L50-105</b>      |
| 1   | 1x TF140684                |
| 2   | 2x <b>powerCLAMP</b> p. 84 |
| 3   | 2x <b>M8X30ISO4762</b>     |
| 4   | 2x PCUSR 14                |
| 5   | 2x <b>M16X55ISO4762</b>    |
| 6   | 2x <b>M5X10ISO7380-1</b>   |
| 7   | 6x M3X6DIN7991             |
| 8   | 2x ACBL4243                |
| 9   | 6x Ø 3x8 VSM 12785         |
| 10  | 2x ACSP7620                |
| 11  | 2x Ø 3h 8x12 ISO 2338      |
| 12  | 6x <b>FED0618</b>          |
| 13  | 1x ACSK7632M16             |
| 14  | 1x FED Ø 5,5x39            |
| 15  | 2x <b>PCD005</b>           |
| 16  | 2x <b>M5X14ISO7380-1</b>   |
| 17  | 4x Ø 6-Niro SM1275-3       |
| 18  | 2x M8X16ISO4017            |
| 19  | 2x M8X20ISO4017            |
| 20  | 2x <b>ACD005</b>           |
| 21  | 2x <b>ACGGB103048</b>      |
| 22  | 4x <b>M5X20ISO7380-1</b>   |
| 23  | 4x Ø 5,2 ISO 4247          |
| 24  | 2x M5x10 DIN 7991          |
| 25  | 2x PCKMR45M8               |
| 26  | 4x d=6 DIN 5401            |
| 27  | 2x TS120001                |
| kg  | ~4,5                       |

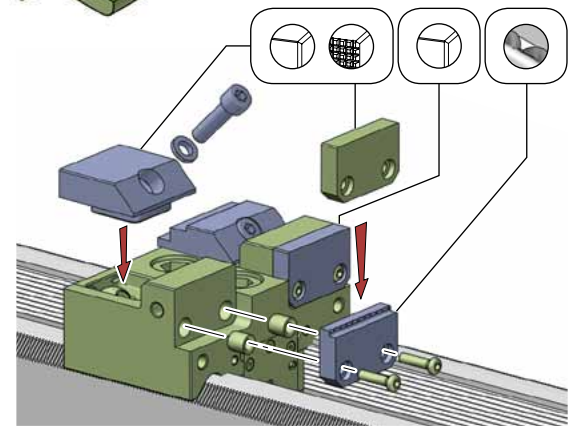
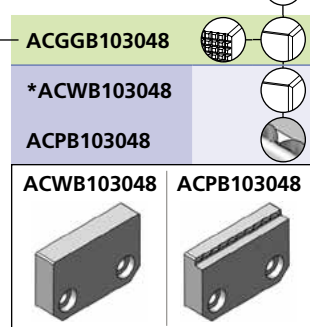
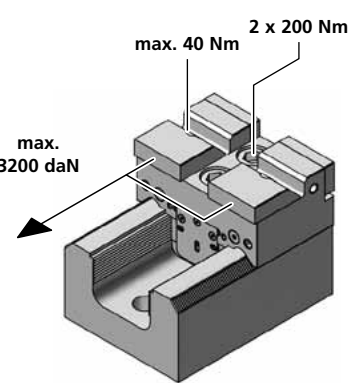
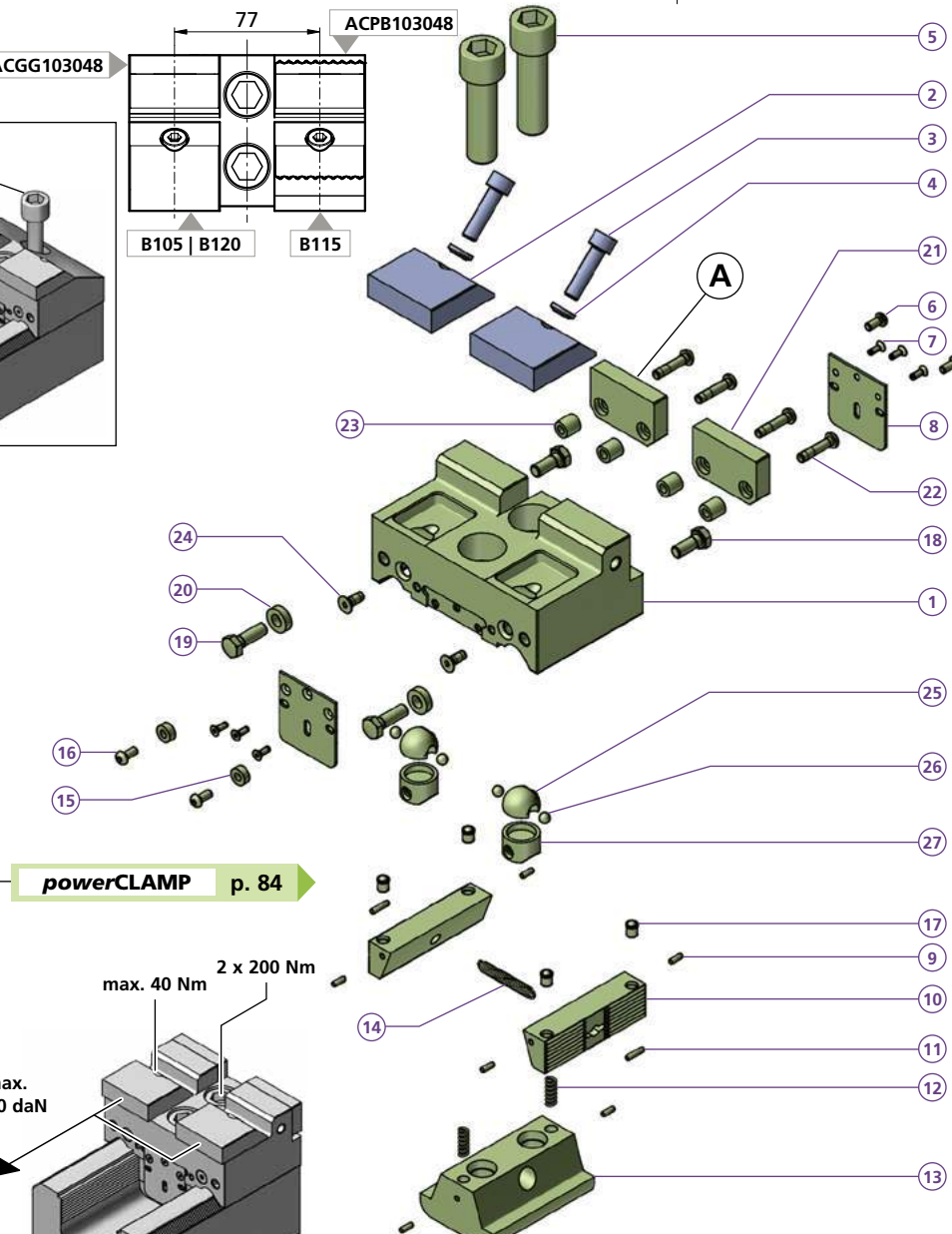

Bestellbeispiel / Ordering example:  
1x AS2X125L50-150 & 2x B105 & 2x ACGGB103048

Separat bestellen / Separate order

\* = weich / soft

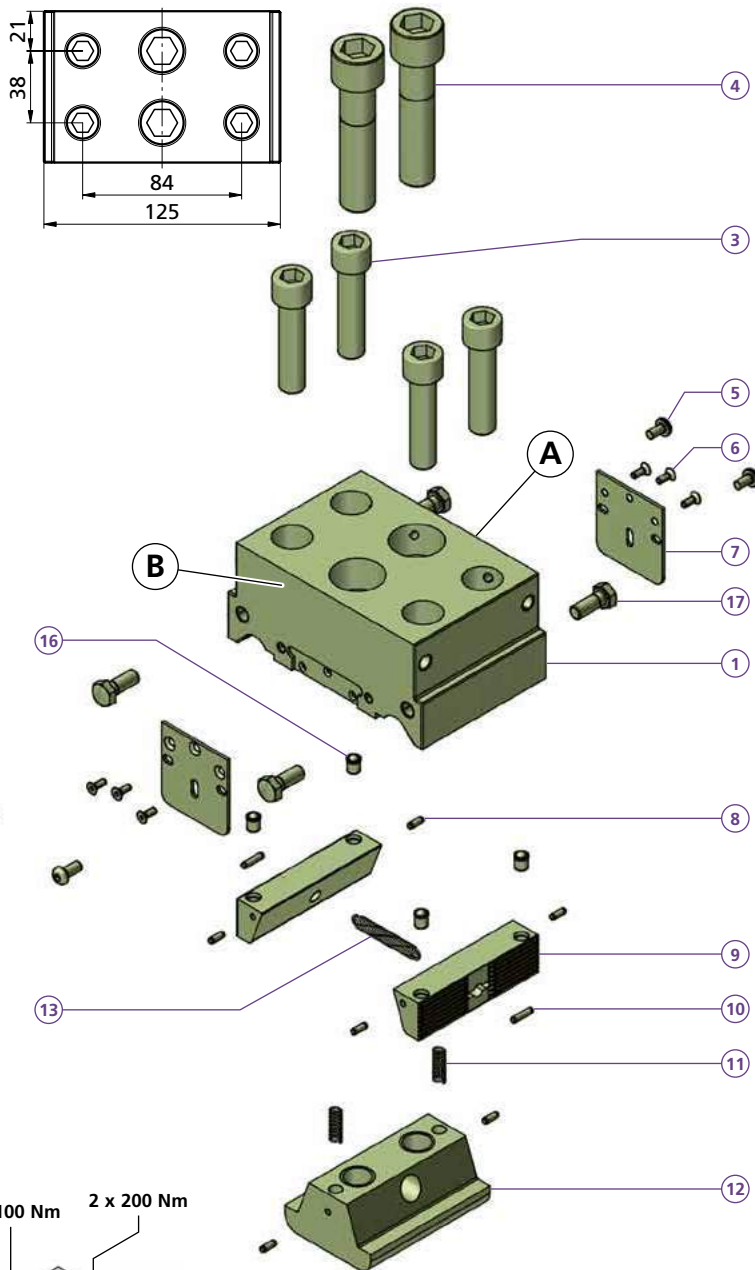
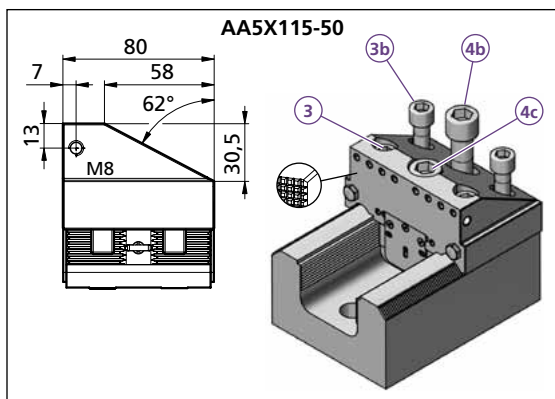
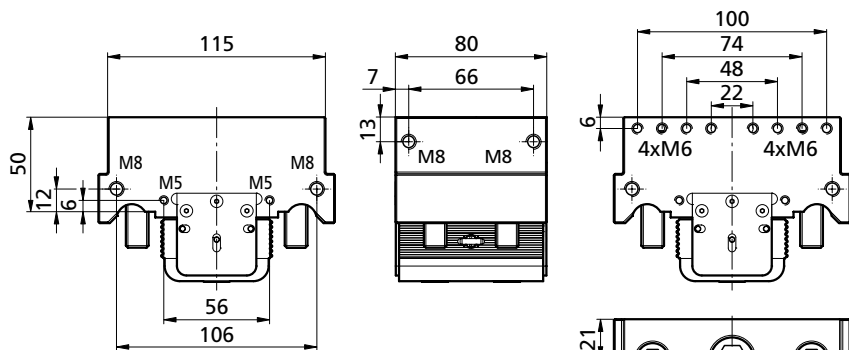

AAND115-50	
1	1x TF140690
3	4x M12X50ISO4762
4	2x M16X70ISO4762
5	4x M5X10ISO7380-1
6	6x M3X6DIN7991
7	2x ACBL4243
8	6x Ø 3x8 VSM 12785
9	2x ACSF7620
10	2x Ø 3h 8x12 ISO 2338
11	2x FED0618
12	1x ACSK7632M16
13	1x FED Ø 5,5x39
16	4x Ø 6-Niro SM1275-3
17	4x M8X16ISO4017
kg	~4,7

AA5X115-50	
1	1x TF140691
3	2x M12X50ISO4762
3b	2x M12X30ISO4762
4c	1x M16X65ISO4762
4b	1x M16X45ISO4762
5	2x M5X10ISO7380-1
17	2x M8X16ISO4017
kg	~4,6

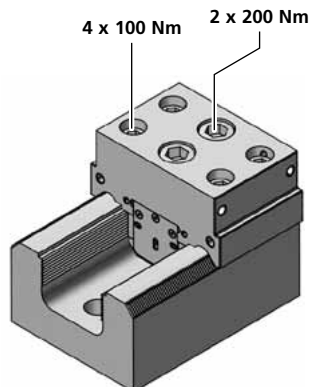



# AAND125-50 AA5X125-50

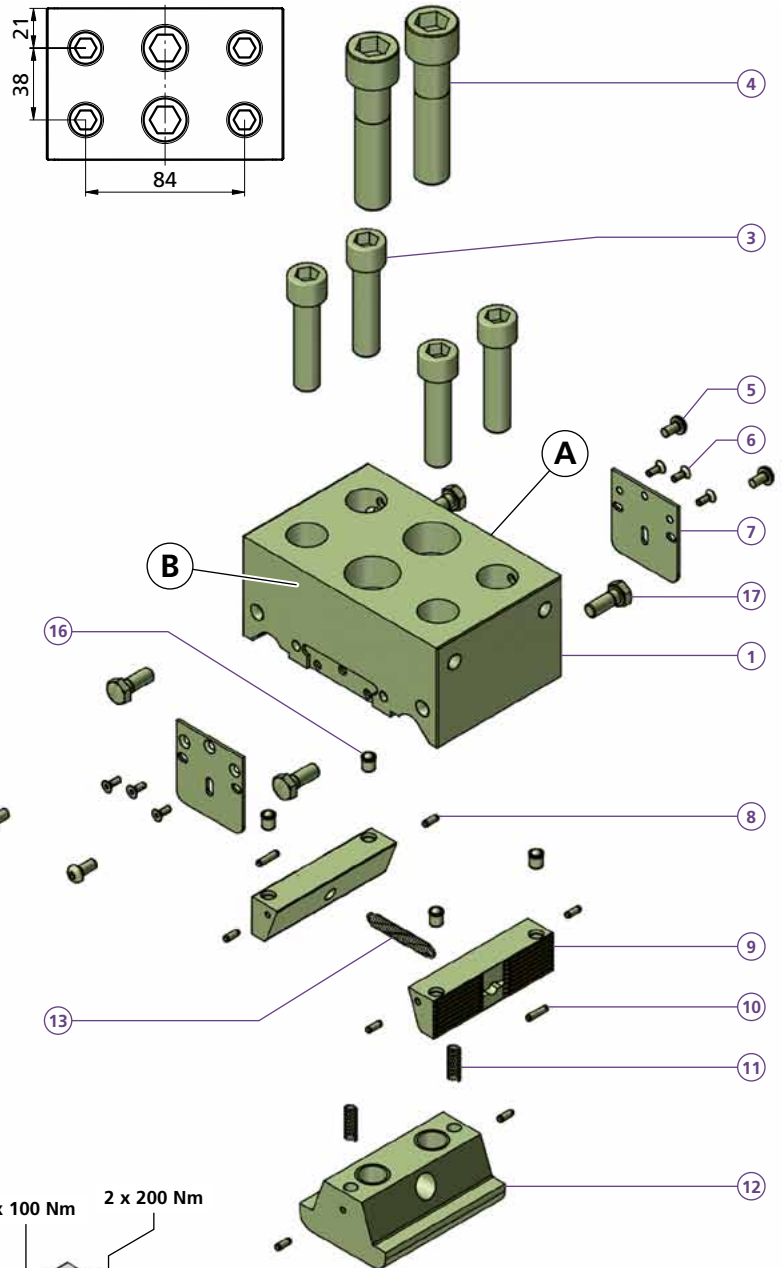
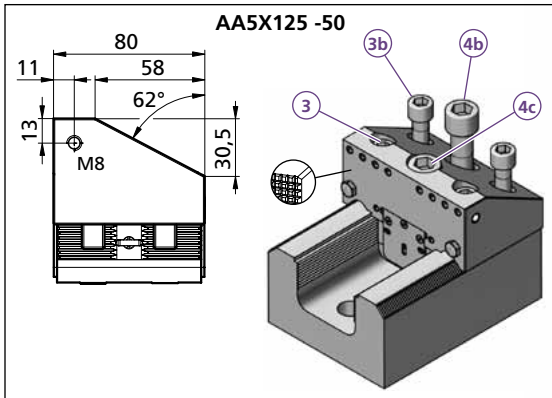
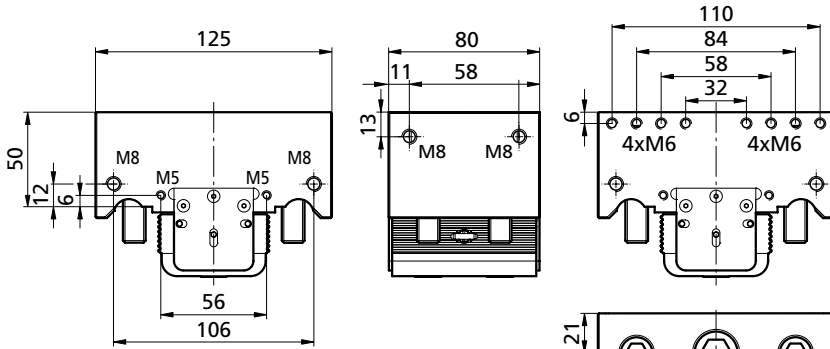

AAND125-50	
1	1x TF140692
3	4x M12X50ISO4762
4	2x M16X70ISO4762
5	4x M5X10ISO7380-1
6	6x M3X6DIN7991
7	2x ACBL4243
8	6x Ø 3x8 VSM 12785
9	2x ACSP7620
10	2x Ø 3h 8x12 ISO 2338
11	2x FED0618
12	1x ACSK7632M16
13	1x FED Ø 5,5x39
16	4x Ø 6-Niro SM1275-3
17	4x M8X16ISO4017
kg	~4,8

AA5X125-50	
1	1x TF140693
3	2x M12X50ISO4762
3b	2x M12X30ISO4762
4c	1x M16X65ISO4762
4b	1x M16X45ISO4762
5	2x M5X10ISO7380-1
17	2x M8X16ISO4017
kg	~4,6

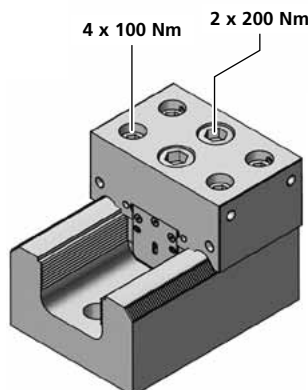

Bestellbeispiel / Ordering example: **AAND125-50**

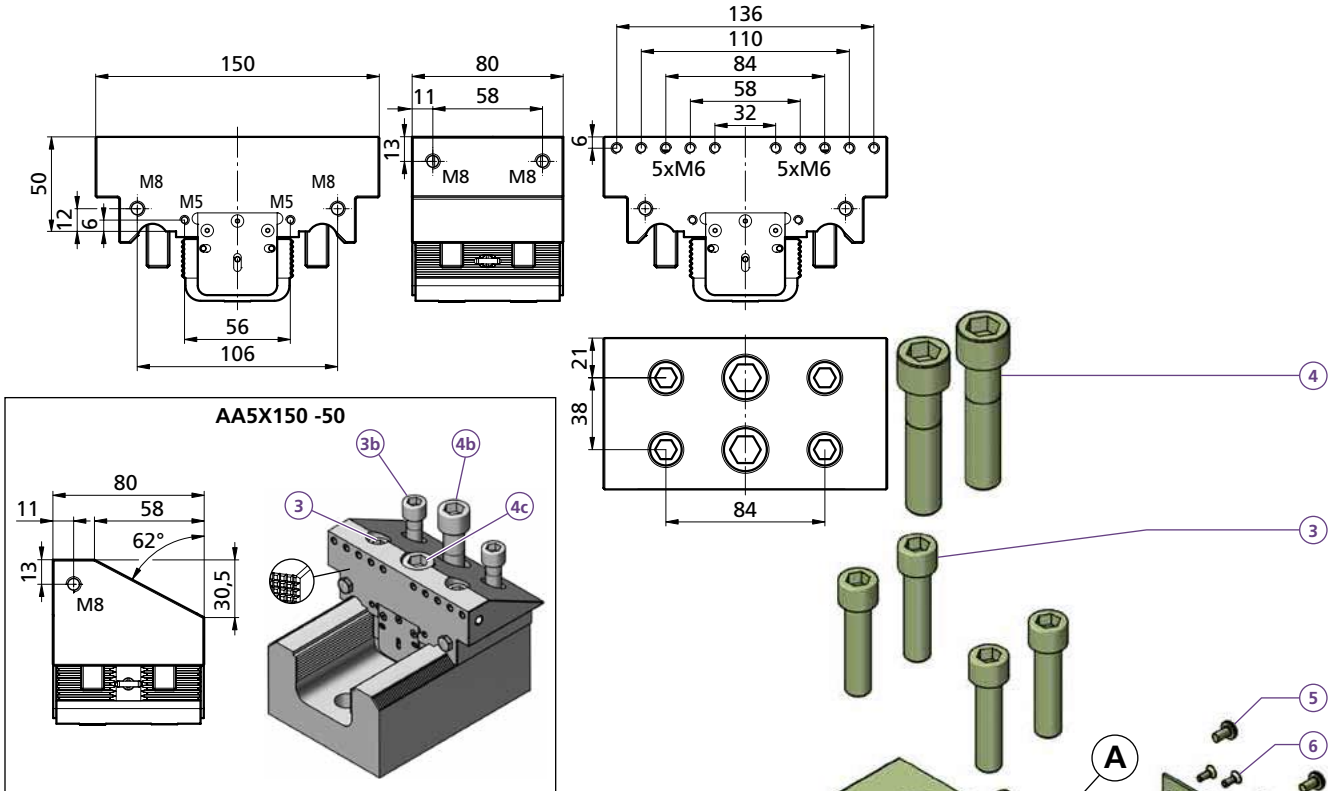

- AAND150-50**
- 1x TF140695
  - 4x M12X50ISO4762
  - 2x M16X70ISO4762
  - 4x M5X10ISO7380-1
  - 6x M3X6DIN7991
  - 2x ACBL4243
  - 6x Ø 3x8 VSM 12785
  - 2x ACSP7620
  - 2x Ø 3h 8x12 ISO 2338
  - 2x FED0618
  - 1x ACSK7632M16
  - 1x FED Ø 5,5x39
  - 4x Ø 6-Niro SM1275-3
  - 4x M8X16ISO4017
- kg ~5,2

- AA5X150-50**
- 1x TF140696
  - 2x M12X50ISO4762
  - 2x M12X30ISO4762
  - 1x M16X65ISO4762
  - 1x M16X45ISO4762
  - 2x M5X10ISO7380-1
  - 2x M8X16ISO4017
- kg ~5,0

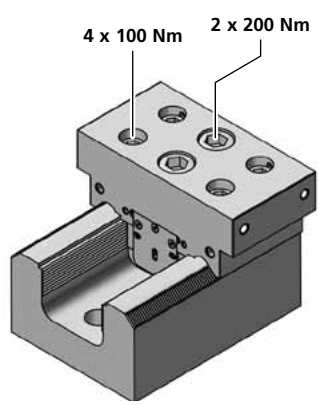

Bestellbeispiel / Ordering example: **AAND150-50**



# AA5X125-50VB

# aptoCLAMP

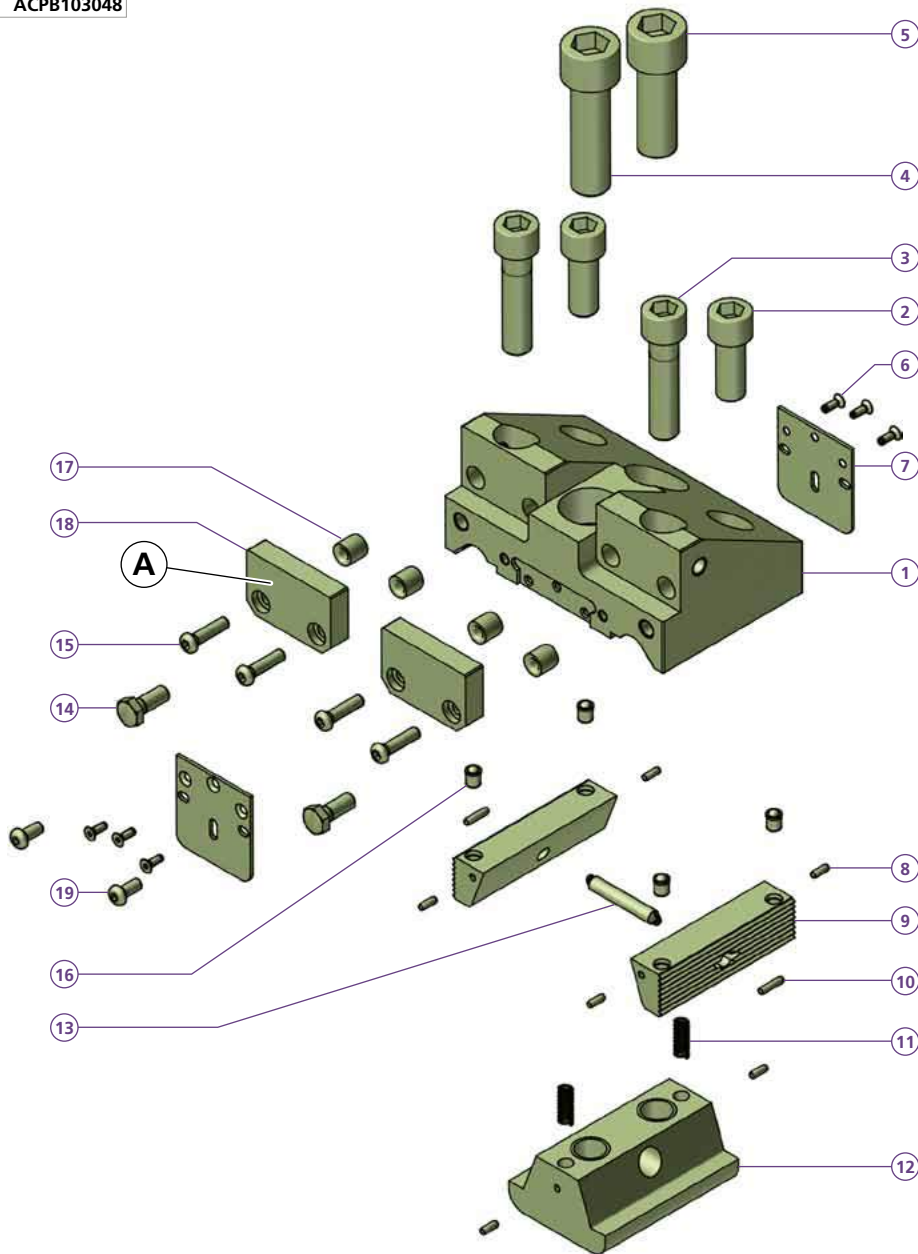
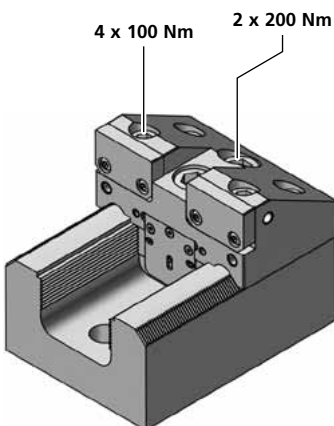
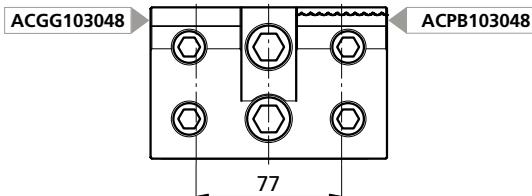
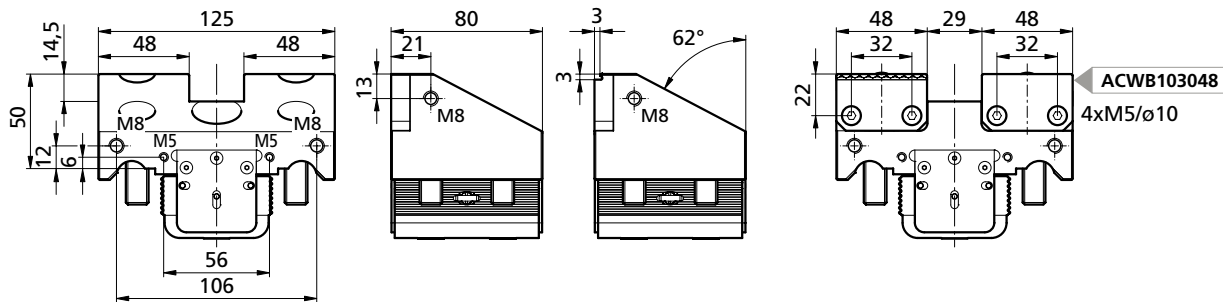

AA5X125-50VB	
1	1x TF140694
2	2x M12X30ISO4762
3	2x M12X50ISO4762
4	1x M16X55ISO4762
5	1x M16X45ISO4762
6	6x M3X6DIN7991
7	2x ACBL4243
8	6x Ø 3x8 VSM 12785
9	2x ACSF7620
10	2x Ø 3h 8x12 ISO 2338
11	2x FED0618
12	1x ACSK7632M16
13	1x FED Ø 5,5x39
14	2x M8X16ISO4017
15	4x M5X20ISO4762
16	4x Ø 6-Niro SM1275-3
17	4x 5,2x10x10 DIN179-A
18	2x
19	2x M5X10ISO7380-1
kg	~4,5

ACGGB103048	
*ACWB103048	
ACPB103048	
ACWB103048	
ACPB103048	

Bestellbeispiel / Ordering example:  
1x AA5X125-50VB & 2x ACGGB103048

Separat bestellen / Separate order





**Parallelunterlage  
Steel parallels**

124mm	B	H	kg
ACU21124	124	21	~0,138
ACU36124	124	36	~0,250
ACU41124	124	41	~0,294
ACU46124	124	46	~0,328

94mm	B	H	kg
PCU14093	93	14	~0,04
PCU20093	93	20	~0,06
PCU24093	93	24	~0,07
PCU29093	93	29	~0,09
PCU31093	93	31	~0,09
PCU34093	93	34	~0,10
PCU39093	93	39	~0,11
PCU44093	93	44	~0,12
PCU46093	93	46	~0,14

125mm	B	H	kg
PCU20124	124	20	~0,08
PCU24124	124	24	~0,09
PCU29124	124	29	~0,11
PCU31124	124	31	~0,12
PCU34124	124	34	~0,13
PCU39124	124	39	~0,15
PCU44124	124	44	~0,17

**Universalnutenstein  
Universal nut**

**ACES6540**

- ① 1x ACZS6540
- ② 1x ACEL6540
- ③ 1x M12X30DIN7984
- ④ 2x SM1275-1KSM8

kg ~ 0,67

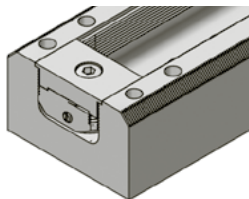

**ACES10240H07**

- ① 1x ACZS6540
- ② 1x ACEL6540-07102
- ③ 1x M12X30DIN7984
- ④ 2x SM1275-1KSM8

kg ~ 0,88

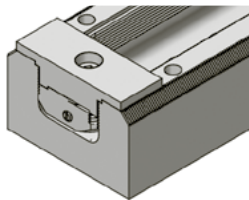

**ACES10040H25W**

- ① 1x ACZS6540
- ② 1x ACEL10040H25W
- ③ 1x M12X30DIN7984
- ④ 2x SM1275-1KSM8

kg ~ 1,42

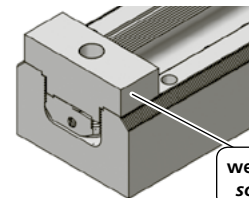

weich  
soft 1.2312

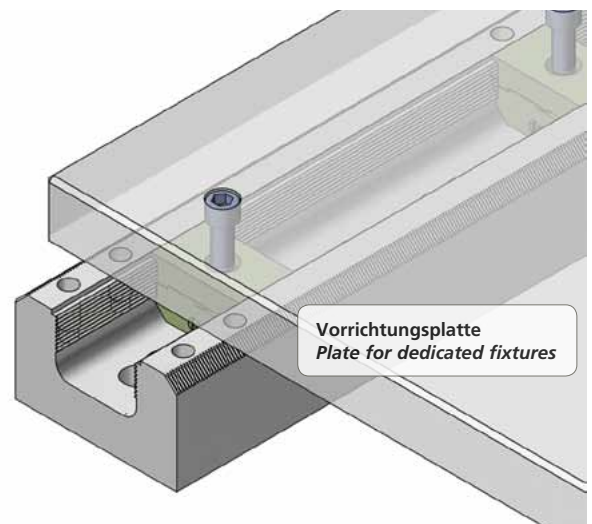

Bestellbeispiel / Ordering example: **ACES6540**

Separat bestellen / Separate order

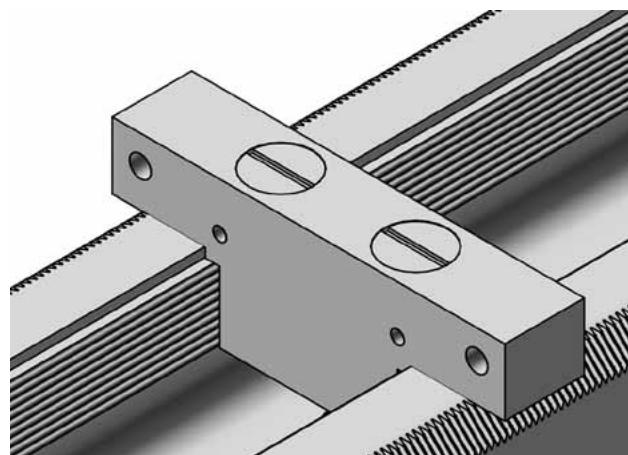
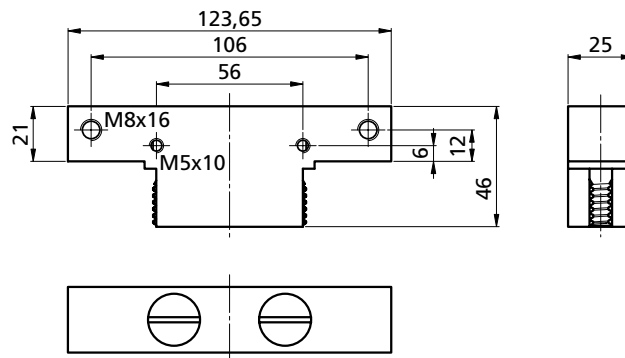
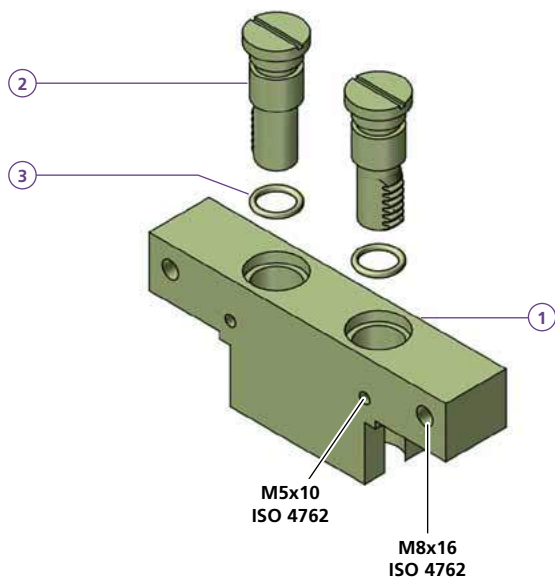

Bestellbeispiel / Ordering example: ACUH21-124

<b>ACUH21-124</b>	
①	1x TW090086-02
②	2x ACBS1646
③	2x OR Ø 12X2
kg	~ 0,74

**weiche Backe**  
**soft jaw**

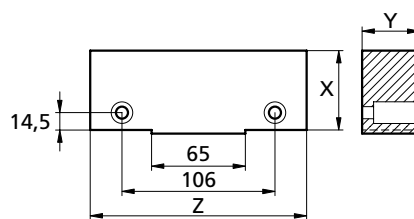
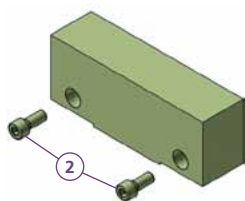

		X	Y	Z	kg
AC1505520W	②	55	20	150	~ 1,28
AC1505540W	M8X20ISO4762	55	40	150	~ 2,55

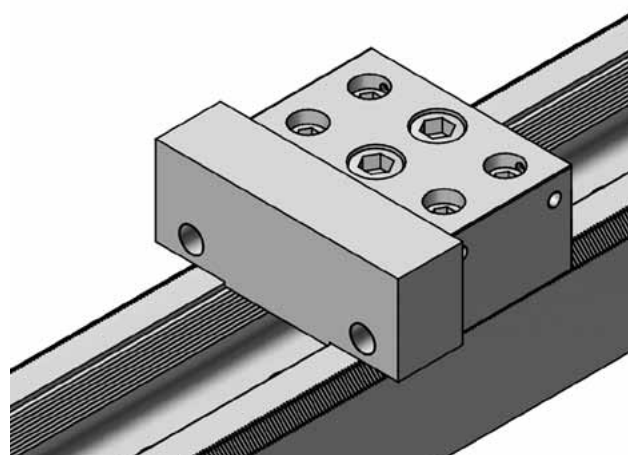

Bestellbeispiel / Ordering example: AC1505520W

<b>Kunde</b> <i>Customer</i>			
<b>Maschine</b> <i>Machine</i>		Werkstoff, Halbzeug, Rohteil-Nr., Modell- oder Gesenk-Nr. <i>Raw material, blank or casting-Nr.</i>	
<b>X</b>	Verfahrweg <i>Traverse</i>		<b>mm</b>
<b>Y</b>	Verfahrweg <i>Traverse</i>		<b>mm</b>
<b>Z</b>	Verfahrweg <i>Traverse</i>		<b>mm</b>
<b>Z min.</b>	kleinster Abstand von der Tischoberfläche zur Spindelnase <i>smallest distance from table surface to spindle gauge line</i>		<b>mm</b>
<b>Z max.</b>	grösster Abstand von der Tischoberfläche zur Spindelnase <i>greatest distance from table surface to spindle gauge line</i>		<b>mm</b>
<b>Ø Spindel</b> <i>Spindle</i>	Spindeldurchmesser <i>Spindle diameter</i>		<b>mm</b>
<b>kg max.</b>	Maximale Tischbelastung <i>Maximum loading capacity</i>		<b>kg</b>
<b>A x B</b>	Tischgrösse <i>Size of the table</i>		<b>mm</b>
<b>E</b>	T-Nuten Grösse <i>T-slots size</i>		<b>mm</b>
<b>C</b>	T-Nuten Abstand <i>T-slots distance</i>		<b>mm</b>
<b>Rasterplatte</b> <i>Grid plate</i>	<b>H</b> Raster Abstand <i>Grid distance</i>	<b>mm</b>	<b>G</b> Gewinde & Passungsdurchmesser Ø <i>Thread &amp; Precision Bohre</i>
	Anzahl Werkstücke pro Los <i>Number of workpieces per lot</i>		<b>Stück</b> <i>Pieces</i>

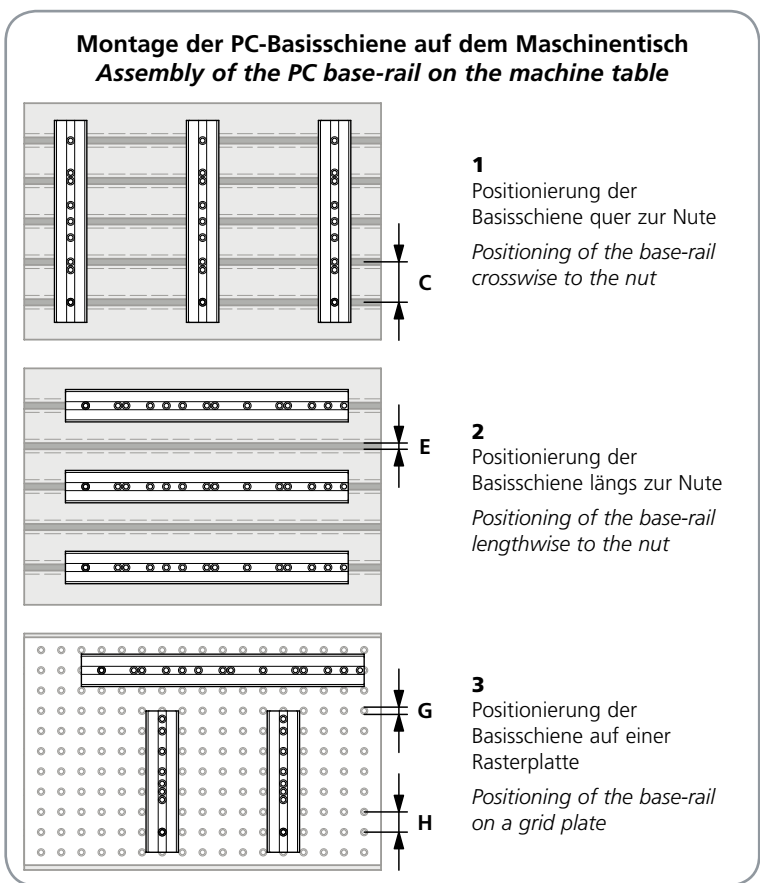
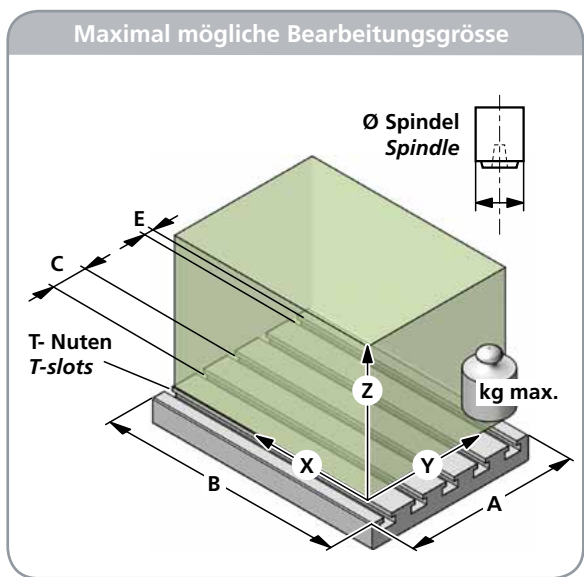

Bitte Werkstückzeichnung beilegen und Bearbeitungsfolge markieren  
*Enclose drawing of workpiece and mark processing sequence, please*



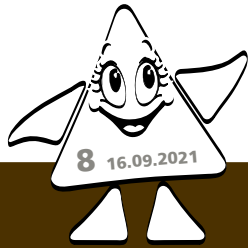
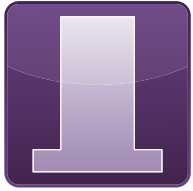

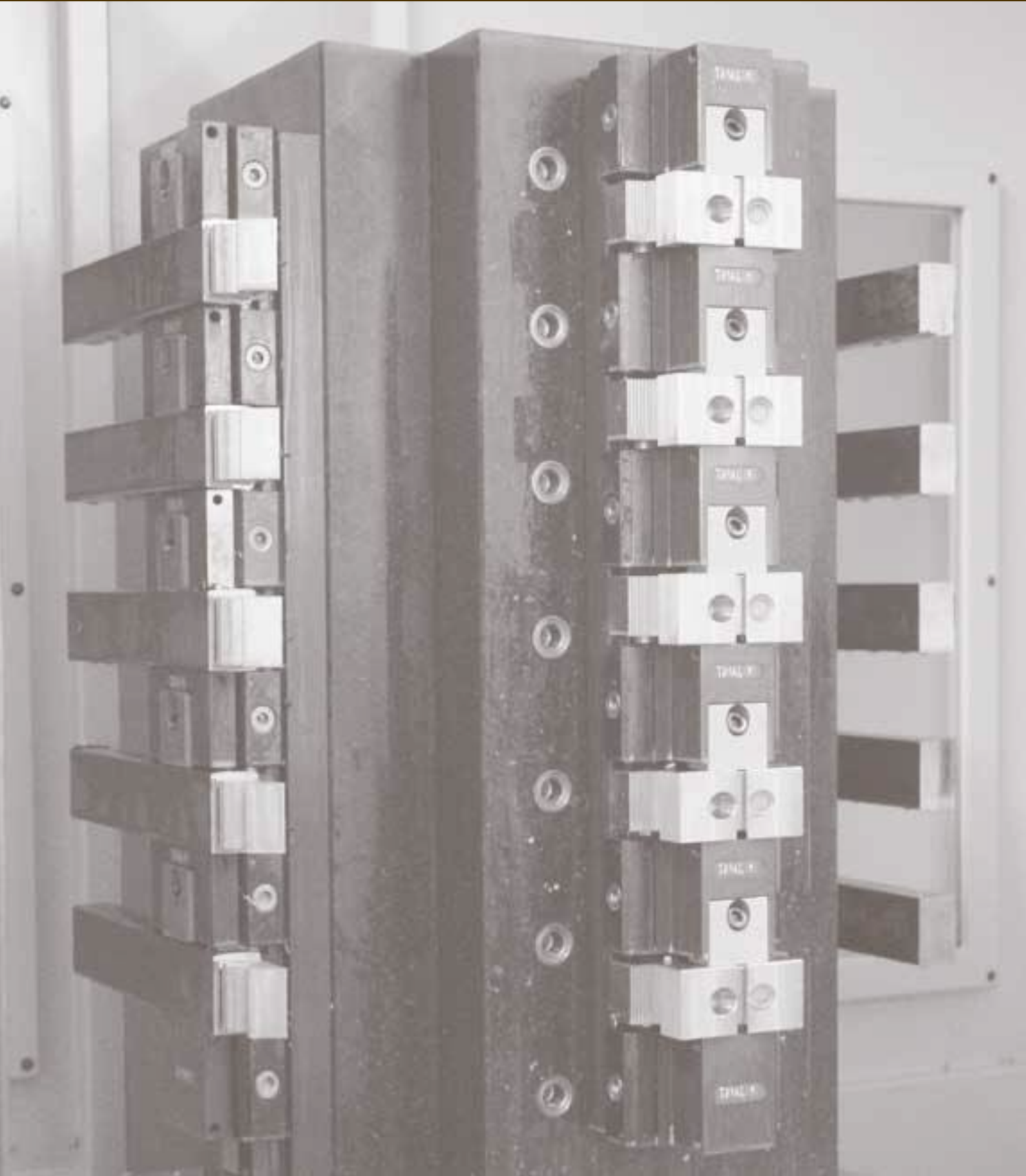

*tripoxy***MINERAL**





 **Einleitung | Introduction** ..... 238 - 243

 **Bedienungsanleitung | Operating manual** ..... 244

**Reparaturanleitung für Mineralguss | How to repair epoxy mineral casting** ..... 245

**Anwendungsbeispiele | Examples of application** ..... 247 - 248

**Mineralguss | Epoxy mineral** ..... 251 - 270

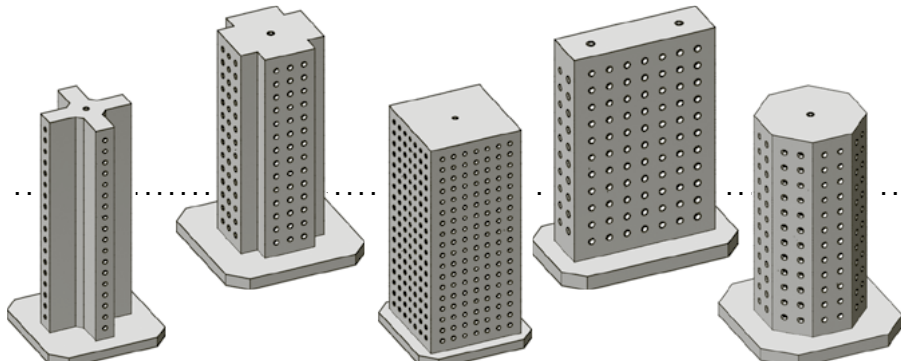

**Mineralgusserhöhung für 5-Achsenmaschinen  
Epoxy riser blocks for 5-axes machines** ..... 271

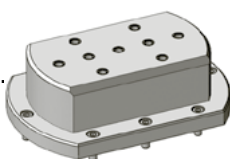

**Stahl Mineralguss | Steel epoxy mineral tombstones** ..... 272 - 273

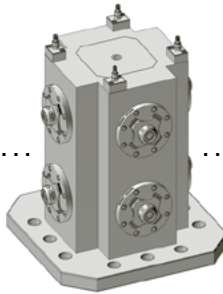

**Zubehör | Accessories** ..... 274 - 275

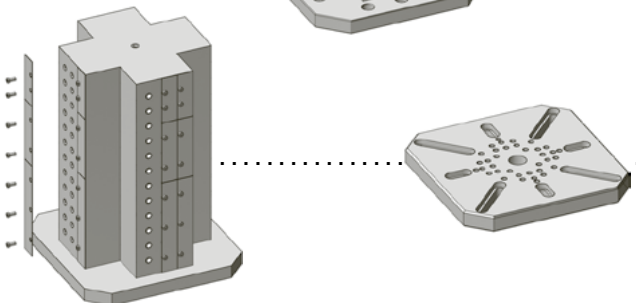

**Stahl-Epoxy Erhöhung mit integriertem Vakuum Anschluss / Steel-epoxy riser block with integrated vacuum  
Balken und Würfel aus Stahl-Mineralguss  
Trunion and cubes made from steel epoxy** ..... 277

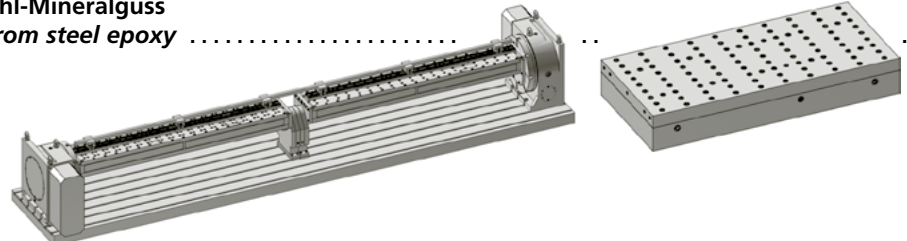



**tripoxyMINERAL**

**Es ist ein versprechen!  
Unsere Mineralgusstürme stehen gerade!**

***It's a promise!  
Our epoxy tomb stones stand upright!***







#### Maschinenschonend und leicht, in fast allen Formen herstellbar

Bei den immer schneller werdenden Horizontalbearbeitungszentren ist Gewichtsreduktion der Zuladung ein wichtiger Faktor. Unsere Spanntürme aus Mineralguss haben ein kleineres spezifisches Gewicht als Alu.

Zudem werden Vibrationen derart reduziert, dass auch bei einer Bearbeitung im oberen Turmbereich präzise bearbeitet werden kann. In gewissen Fällen, z.B. bei Werkstückspannungen (ohne Basisschienen) direkt auf den Turm, kann auch ein stahlummantelter Mineralgussturm eine Ergänzung sein.

#### Reduces machine wear due to low specific weight - can be produced in all sorts of shapes

As the rapid traverse on modern horizontal machining centres is constantly increasing, the weight of the payload becomes obviously an important point. Our tombstones made of epoxy mineral casting are lighter in their specific weight than aluminium.

In addition, vibrations are greatly reduced in a way that even in the upper end of the tombstone high accuracy is guaranteed. In certain cases, as for instance when the fixture is designed without the base rail, that means directly mounted on the cube, the tombstone can be improved by a steel jacket.

- Leicht und stabil
- Vibrationsdämpfung 10 x besser als Grauguss und 100 x besser als Alu!
- Spezifisches Gewicht leichter als Aluminium
- Seitenflächen geschliffen mit Bohrungen (M12 / 12F7)
- Grundplatten nach Maschinenspezifikation
- Andere Formen auf Anfrage

- *Lightweight and rigid*
- *Damping effect 10 x better than cast iron 100 x better than alu!*
- *Specific weight lighter than aluminum*
- *Faces ground, hardened bushings (M12/12F7)*
- *Base plate made to machine specifications*
- *Other dimensions on request*



Chaotische Spannung (Tripoxy Mineral) mit unterschiedlichen Werkstücken bestückt. Optimale Nutzung eines Horizontal-Bearbeitungszentrums. Mixed set up on a Mazak horizontal machine with 18 pallets. This is used for unmanned production of small quantities of different materials.



Mineralguss (auch Polymerbeton genannt) ist ein Kunststein, bestehend aus Quarzkies, Quarzsand und Gesteinsmehl. Als Binder dient ein hochwertiger Epoxidharz. Das gemischte Material wird in Giessformen gefüllt.

Während dem Giessprozess wird die Form, mittels Vibrations-tisch ständig vibriert, was zur Verdichtung und Entlüftung der Giessmasse führt. Das spezifische Gewicht ist mit 2,4 kg / dm<sup>3</sup> geringer als das von Aluminium und die Vibrationsdämpfung ist 10 mal besser als bei Grauguss, 100 mal besser als Aluminium. Neben den guten Dämpfungseigenschaften ist auch die Temperaturstabilität (geringe Wärmeleitfähigkeit und hohe Wärmekapazität) zu erwähnen.

Das Material ist ausserdem chemisch beständig gegen Öle, Laugen, Säuren und die üblichen Kühlschmierstoffe. Im ausgegossenen Zustand sind die Türme «Umweltneutral».

*Mineral casting (also called polymer concrete) is a stone composed of quartz gravel, silica sand and crushed rock. The binder is a high quality epoxy resin. The mixed material is filled into molds.*

*During the casting process, the form, constantly vibrating. Is resulting in the compaction and extraction of the casting mass. The specific weight is 2,4 kg / dm<sup>3</sup> is lower than that of aluminum, and the vibration attenuation is 10 times better than that of cast iron 100 times better than alu. Besides the good damping properties, the temperature stability is to be mentioned (low thermal conductivity and high heat capacity).*

*The material is also chemically resistant to oils, alkalis, acids and the usual cooling lubricants.*

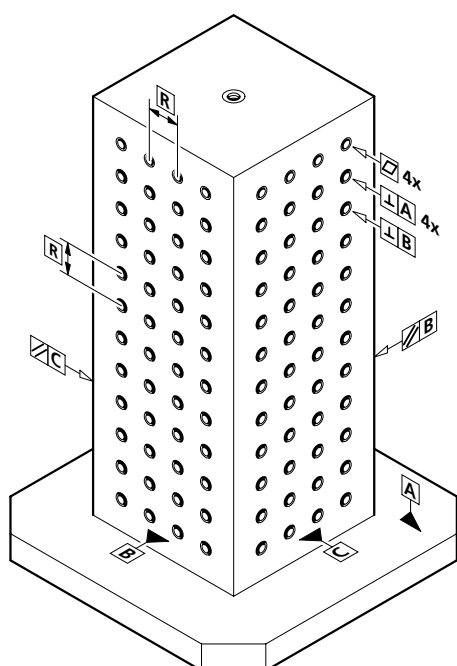

Eigenschaften Caractéristiques	Mineralguss Epoxy mineral	GG20	hochfestes Alu high density Alu
Dichte / Density [kg/dm <sup>3</sup> ]	ca. 2,4	ca. 7,1-7,3	ca. 2,76
Logarithmisches Dekrement grösser als (Vibrationsdämpfung) Logarithmic Decrement (damping)	0,035	0,004	0,0004
Längenausdehnungs-koeffizient Coefficient of linear expansion [1/K]	ca. 12x10 <sup>-6</sup>	ca. 10x10 <sup>-6</sup>	ca. 23x10 <sup>-6</sup>
Zugfestigkeit / Tensile strength [N/mm <sup>2</sup> ]	15 - 20	200 - 400	470 - 520
Wärmeleitfähigkeit Thermal conductivity [W/mK]	ca. 2	ca. 50	ca. 140

Lagetoleranz der Rasterbohrungen Positioning tolerance of the holes	<b>R</b>	<b>0 - 500 mm ± 0,01</b> <b>501 - 1000 mm ± 0,02</b>
Ebenheit Flatness		<b>0,01 mm / 300 mm</b>
Parallelität Parallelism		<b>0,01 mm / 300 mm</b>
Winkligkeit Deviation of angle		<b>0,01 mm / 200 mm</b>

### Mineralguss wird unter anderem für folgende Anwendungen eingesetzt: Cast mineral is among other things the following Applications used:

- ➔ Maschinenbetten  
Machine beds
- ➔ Maschinenständer und -portale  
Machine column and portals
- ➔ Als Alternative zu Grauguss (Kosten, Umweltfreundlichkeit)  
As an alternative to cast iron (cost, environmental friendliness)
- ➔ Als Alternative zu Schweisskonstruktionen  
As an alternative to welded constructions
- ➔ Als Alternative zu Natursteinanwendungen (z.B. Messtische, Reinraumtechnologie)  
As an alternative to natural stone applications (eg, measuring tables, clean room technology)
- ➔ Generell steifigkeits- und festigkeitsdimensionierte Strukturbauteile  
General stiffness and strength-scale structural components
- ➔ Integrierte Funktionalität möglich (Schläuche, Ventile, Elektrik, Lastanker etc.), auch nachträgliches Eingiessen möglich  
Integrated functionality possible (hoses, valves, electrical, anchor load, etc.), and subsequent pouring possible
- ➔ Füllung von Mineralguss in Blechmantelkonstruktionen (z.B. unsere Stahl-Mineralguss-Basissschienen)  
Filling of mineral cast in metal shell constructions (eg, our steel rails with epoxy mineral cast base)



**tripoxyMINERAL**

Die Gewichtsreduktion der Zuladung ist bei den immer schneller werdenden Horizontalbearbeitungszentren ein wichtiger Faktor. Die Spanntürme aus Mineralguss haben ein kleineres spezifisches Gewicht als Aluminium. Diese verfügen über eine so hohe Vibrationsdämpfung, dass dadurch im oberen Bereich der Türme sehr präzise gearbeitet werden kann und dabei exzellente Oberflächengüten erreicht werden.

Seit Jahren bietet die Triag International AG aus eigener Produktion mit den Tripoxy Mineral-Spanntürmen eine sehr gute Alternative zu Spanntürmen aus anderen Materialien (z.B. Grauguss- oder Aluminium) an.

*The weight reduction of the load is an important factor in the increasingly rapid horizontal machining centers. The tombstones of mineral casting have a lower specific weight than aluminum. Another big advantage is the vibration clamping which helps to achieve excellent surfaces on your workpieces, even on top of your tombstone. Beside that there are another two good reasons for epoxy mineral tombstones. One is the materials is not getting rusty and the slow thermal expansion.*

*For years, the Triag International AG offers its own production with the Tripoxy mineral tombstones, a very good alternative to tombstones made of other materials (such as cast iron or aluminum) to.*

**Mineralgusstürme samt  
 Spansystem aus einer Hand!**

***Epoxy mineral tombstones including  
 clamping system from one source!***



**Mineralgussturm kombiniert bestückt mit Power Clamp und Magneten.  
 Epoxy cube equipped with magnet and Power Clamp**



**Grosse Platte auf einem rechteckigen  
 Mineralgussturm.  
 Large plates on epoxy tombstone.**



**Chaotische Fertigung auf einem  
 Mineralgussturm in Kreuzform.  
 Mixed set up on cross epoxy tombstone.**



**Spezielle Vorrichtung mit Micro Clamp  
 Modulen auf einem Mineralgussturm.  
 Dedicated fixture on epoxy tombstone**



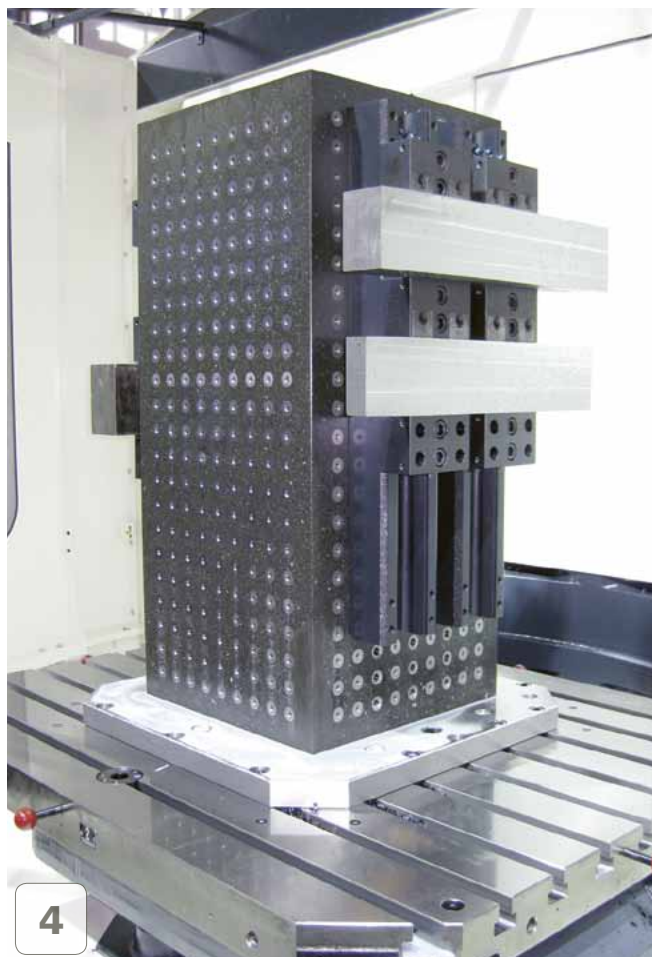





**Stahl-Mineralguss seit 2004 - das ideale Material für Spanntürme**

Die Firma Triag International AG hat seit 2004 diese stahlummantelten Türme mit sehr guten Ergebnissen bei Kunden im Einsatz. In den meisten Fällen können optimale Lösungen durch Standardangebote kostengünstig und modular eingerichtet werden.

**Steel-epoxy combinations since 2004 - the ideal material for tombstones and ricer cubes**

Triag International AG customers are employing successfully tombstones with steel jackets since 2004. In most cases optimal solutions can be found with standard Triag clamping devices.

Stahl-Mineralguss für die perfekte Vibrationsdämpfung  
 Steel epoxy tombstone for perfect vibration dampening

Max. Palettenzuladung auf Mazak H BZ  
 Max pallet load on this Mazak application = 600kg H = 800

Komplettes Gewicht 600 kg inkl. Werkstücke WS = 8 x 38 kg  
 Complete load weighs 600 kg incl-parts

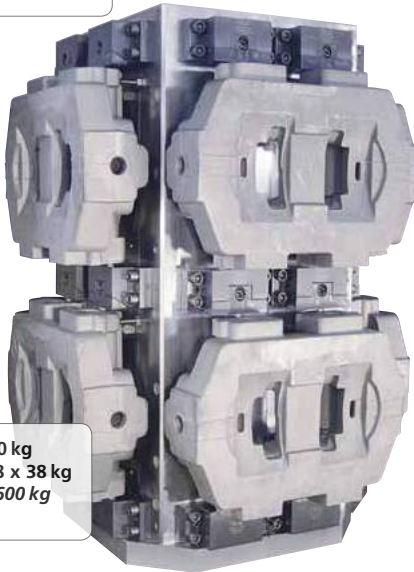

**200 x 400 x 1330**

Flügelteil für Airbus A320  
 Tail wing part for Airbus A320

Stahlmineralguss-Säulen mit Power Clamp für die Fertigung von Flügelteilen.  
 Steel epoxy frames machining wing parts on a Makino machine

Stahl-Mineralguss Dreieck-Turm  
 Steel epoxy triangle cube



Stahl-Mineralguss Pyramide  
 Steel epoxy pyramid stomp



Stahlmineralgussturm mit Power Clamp zum Leistungsfräsen in Werkzeugstahl (unbemannt).  
 Steel epoxy tombstone with Power Clamp 10 pcs of tool steel are machined (running time 5,3 hours)

Es gibt eine Vielzahl von Standardformen

*There are a variety of standard forms*



**tripoxyMINERAL**

Die Mineralgusstürme können in fast allen

*The epoxy mineral tombstones can be manu-  
factured in almost any shape.*

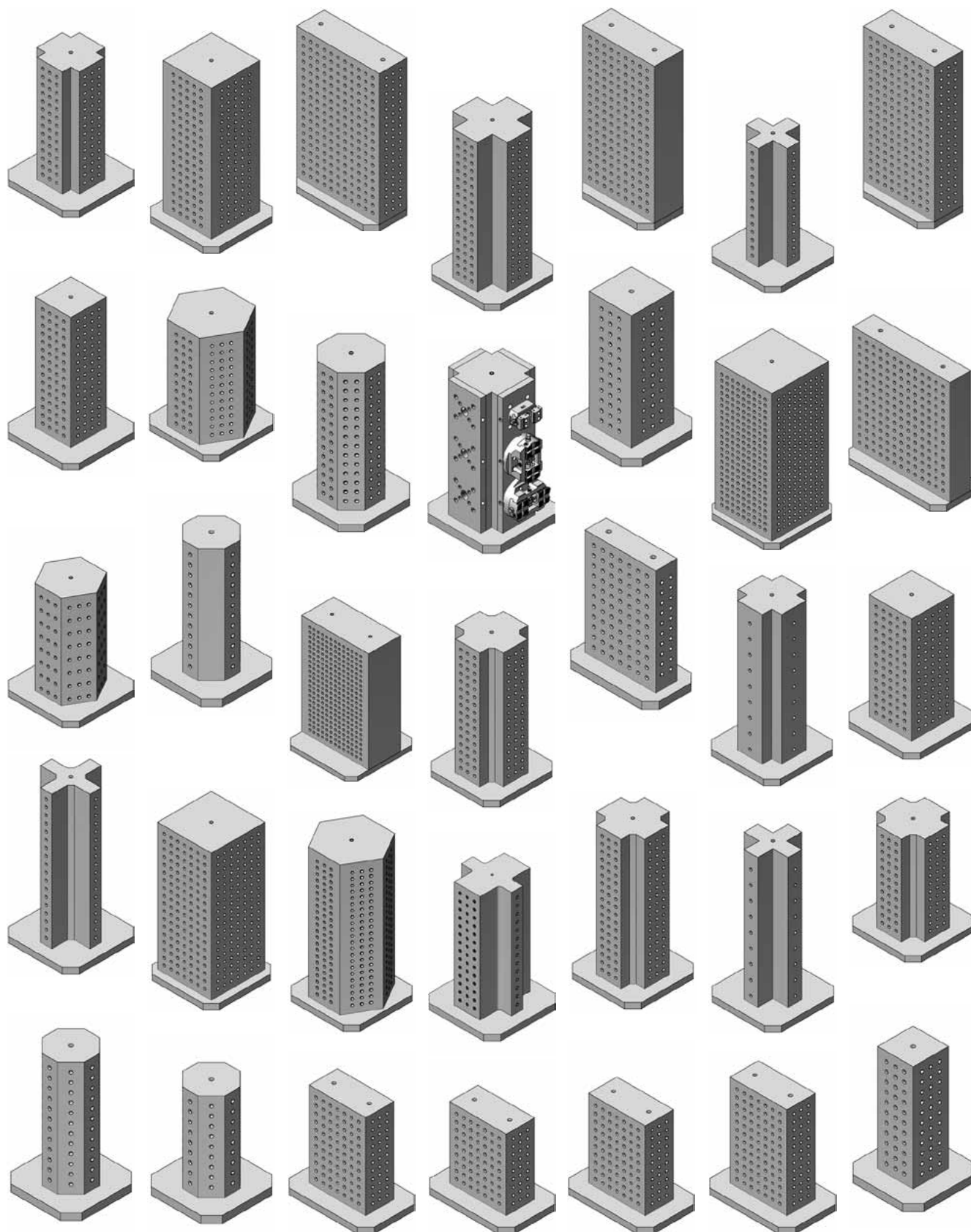

Andere Größen, Formen und Raster, welche nicht im Katalog sind, können nach Kundenwunsch produziert werden.  
*Other sizes, forms and grid which are not in the catalogue can be produced on customer's request.*





**ACHTUNG / CAUTION**

**Bevor Mineralgusstürme eingesetzt werden, beachten Sie bitte die folgenden Punkte!** *Prior to inserting the tombstones please note the following points!*

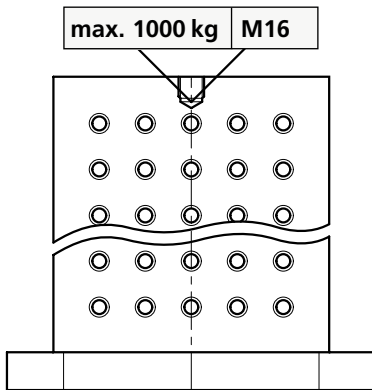

Höchstlast des angehängten Stücks / Maximum load of the affixed piece		
Drahtseil Steel rope	Bei fest angezogener Schraube For tightened screw	Bei zwei Schrauben insgesamt For two tightened screws
MRD 12 = 500 kg MRD 16 = 1000 kg	M12 = 340 kg M16 = 700 kg (DIN 580)	M12 = 240 kg M16 = 500 kg (DIN 580)

Bitte beachten Sie, dass die meisten Ringschrauben eine maximale Last haben von: **M12: 340 kg / M16: 700 kg** auch muss die Ringschraube bis zum Anschlag eingedreht sein!

*Please note that most of the lifting screws have a maximum load of: **M12: 340 kg / M16: 700 kg** It is also important that the lifting screw is driven into the socket!*

**Oberflächenabnutzung**

Durch schnelle, auf die Turmoberfläche schlagende Späne, sowie durch Hochdruckkühlung, die direkt auf den Turm spritzt, kann die Oberfläche des Mineralgussturmes beschädigt werden!

**Surface wear**

*The surface of the tombstone can be seriously damaged by chips hitting the tombstone quickly as well as by high pressure cooling water splashing directly onto the tombstone!*

**Massnahmen:**

Dort wo lange Späne oder auch kurze abrasive Späne auf den Turm schlagen, Abdeckbleche benutzen! (Abdeckbleche siehe Seite 244)

**Measure:**

*Use cover sheets wherever long or short abrasive chips hit the tombstone! (Cover sheets page 244)*

**Achtung Grenzfälle**

Folgende Anwendungen können nur bedingt eingesetzt werden, da eine einzelne Schraube auf Zug ohne Gegenlast die eingegossene Buchse belastet!

**Attention, limited application**

*The following applications only have limited use as a single screw without a counterweight puts tremendous tension on the integral socket!*



**Max. Anzugsmomente beachten.**

**Note max. starting torques.**

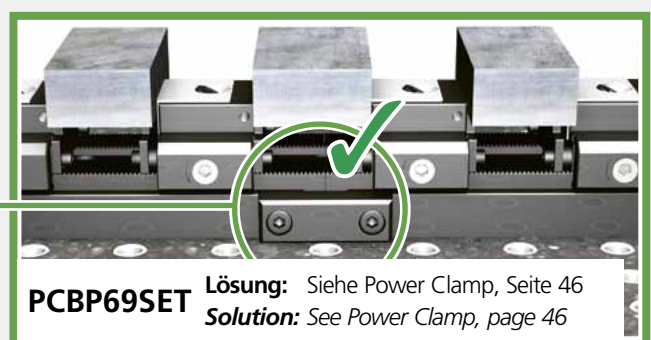
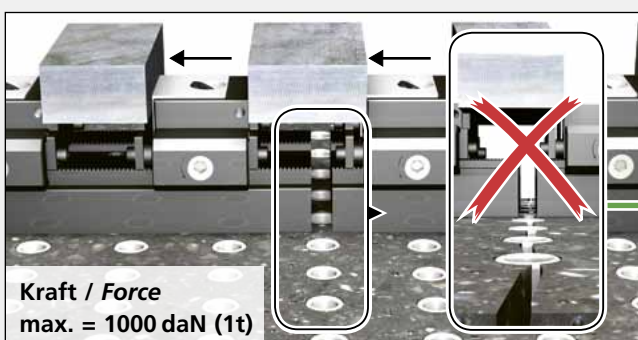
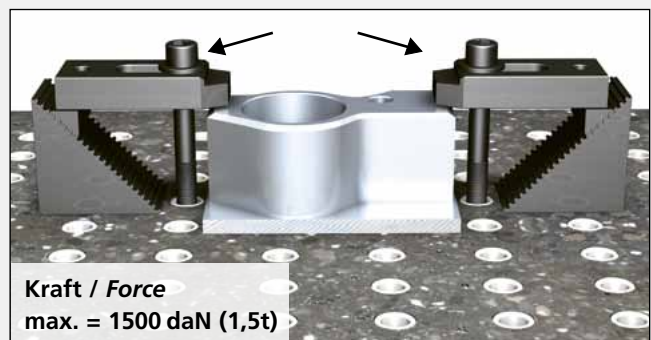
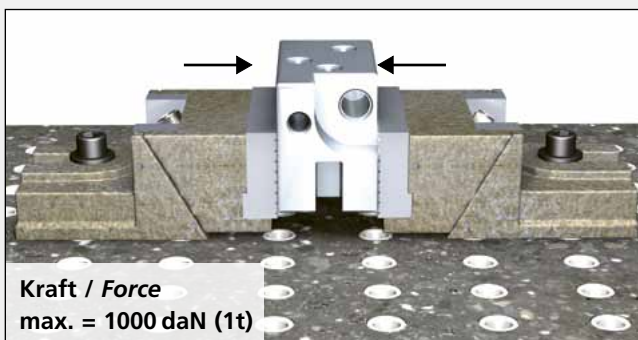



#### Bruchstelle

Bruchstelle des Mineralgussturmes mit Aceton reinigen, danach mit Metallplatte und Schraubzwinge einschalen. Bei grossen Reparaturen sollte die Platte zusätzlich mit Hartwachs (Bild 6) eingerieben, poliert und nachträglich mit Silikon abgedichtet werden. (Siehe Bilder 1-4)

#### Mineralgussreparaturset (Bild 5)

##### MREP-SET 0300 ~ 300 gr = ~ 2 dl

Das Reparaturset setzt sich aus dem Harz, Härter und Füller zusammen. Das Mischverhältnis ist: auf 27 gr Härter kommt 100 gr Harz und 150 gr Füller.

#### Das Verhältnis ist genau abgewogen. Wichtig ganze angelieferte Menge gebrauchen.

Harz und Härter zusammengiessen und intensiv 2 Min. rühren. Das Durchmischen der Masse ist entscheidend für das optimale Abbinden des Mineralgusses. **Danach Füller dazugeben und das gleiche nochmals 2 Min.** lang untereinander mischen bis eine gipsähnliche Masse entsteht.

Die flüssige Masse wird nun in die Bruchstelle eingegossen.

Das Aushärten der Reparaturmasse beträgt 24 Std. Die Unebenheit der frisch eingegossenen Fläche, wird mit einem Schleifstein plangeschliffen.

#### Point of rupture

Clean the section of fracture with Acetone, then press metal plates with screw clamps onto the point of damage. If the damage is a major one the metal plates must be waxed first (picture No. 6) and sealed with Silicon if necessary (pls. note pictures 1 to 4)

#### Repair kit for epoxy mineral castings (picture 5)

##### MREP-SET 0300 ~ 300 gr = ~ 2 dl

The repair kit consists of the resin, the hardener, and the filler. The mixture ratio is: 27 gr of hardener, 100 gr of resin and 150 gr of filler.

#### These components are exactly portioned in the kit and should be used up entirely.

The resin and the hardener should be poured together and mixed for 2 min. This mixing process is essential for a good bonding with the mineral casting. **Then the filler should be added while mixing the mass another 2 min.** It will reach a consistency like plaster.

This mortar must be poured into the point of rupture.

The hardening process takes 24 hours. Protruding material can be levelled with a grindstone.

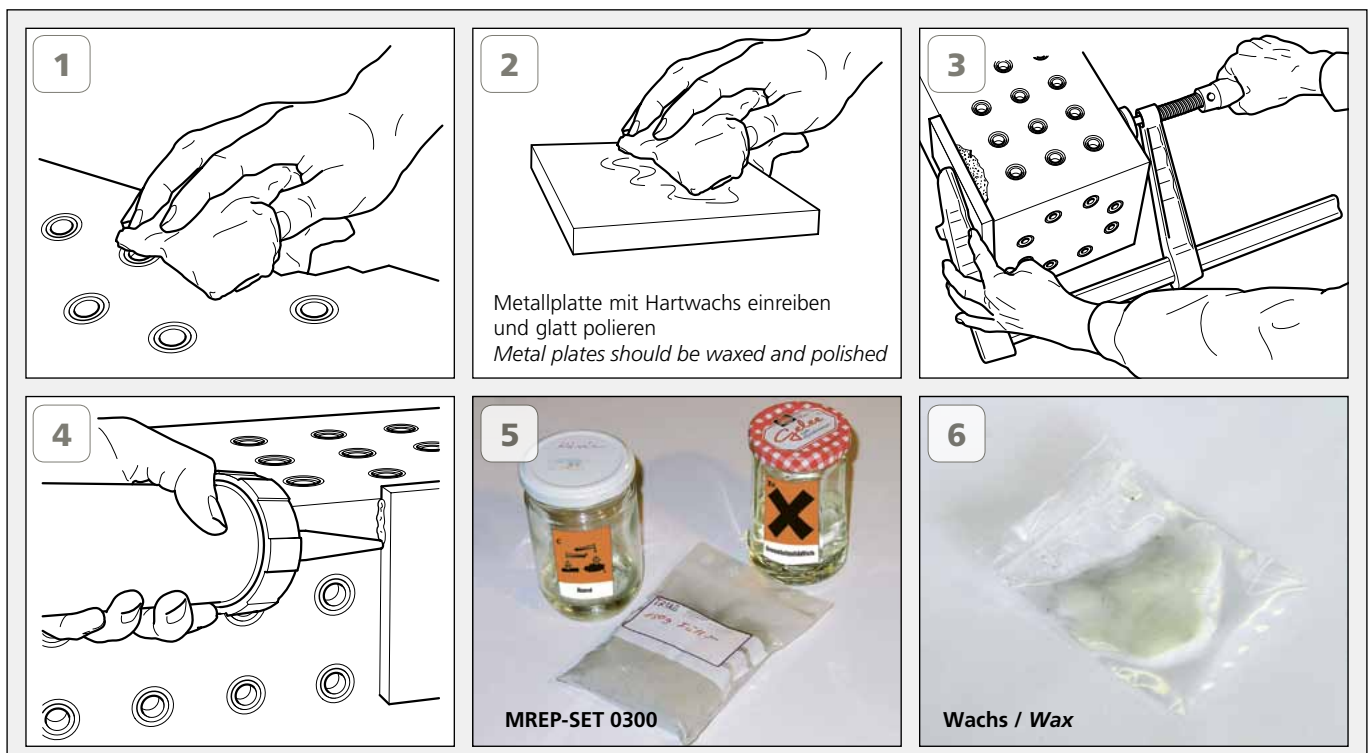



<b>Kunde</b> <i>Customer</i>			
<b>Maschine</b> <i>Machine</i>		Werkstoff, Halbzeug, Rohteil-Nr., Modell- oder Gesenk-Nr. <i>Raw material, blank or casting-Nr.</i>	
<b>X max.</b>	X Achse Hub <i>X axis stroke</i>		<b>mm</b>
<b>Y min.</b>	Kleinster Abstand von der Palettenoberseite zur Spindelachse <i>Smallest distance from pallet surface to spindle center</i>		<b>mm</b>
<b>Y max.</b>	Grösster Abstand von der Palettenoberseite zur Spindelachse <i>Greatest distance from pallet surface to spindle center</i>		<b>mm</b>
<b>Z min.</b>	Kleinster Abstand von der Palettenachse zur Spindel Nase <i>Smallest distance from pallet center to spindle gauge line</i>		<b>mm</b>
<b>Z max.</b>	Grösster Abstand von der Palettenachse zur Spindel Nase <i>Greatest distance from pallet center to spindle gauge line</i>		<b>mm</b>
<b>∅ Spindel</b> <i>Spindle</i>	Spindeldurchmesser <i>Spindle diameter</i>		<b>mm</b>
<b>kg max.</b>	Maximale Tischbelastung <i>Maximum loading capacity</i>		<b>kg</b>
<b>∅D max.</b>	Maximaler Störkreis des Werkstücks <i>Maximum workpiece diameter</i>		<b>mm</b>
<b>H max.</b>	Maximale Beladehöhe des Werkstücks <i>Maximum workpiece height</i>		<b>mm</b>
<b>A x B</b>	Palettenabmessung <i>Size of pallet</i>		<b>mm</b>
	Anzahl Werkstücke pro Los <i>Number of workpieces per lot</i>		<b>Stück</b> <i>Piece</i>

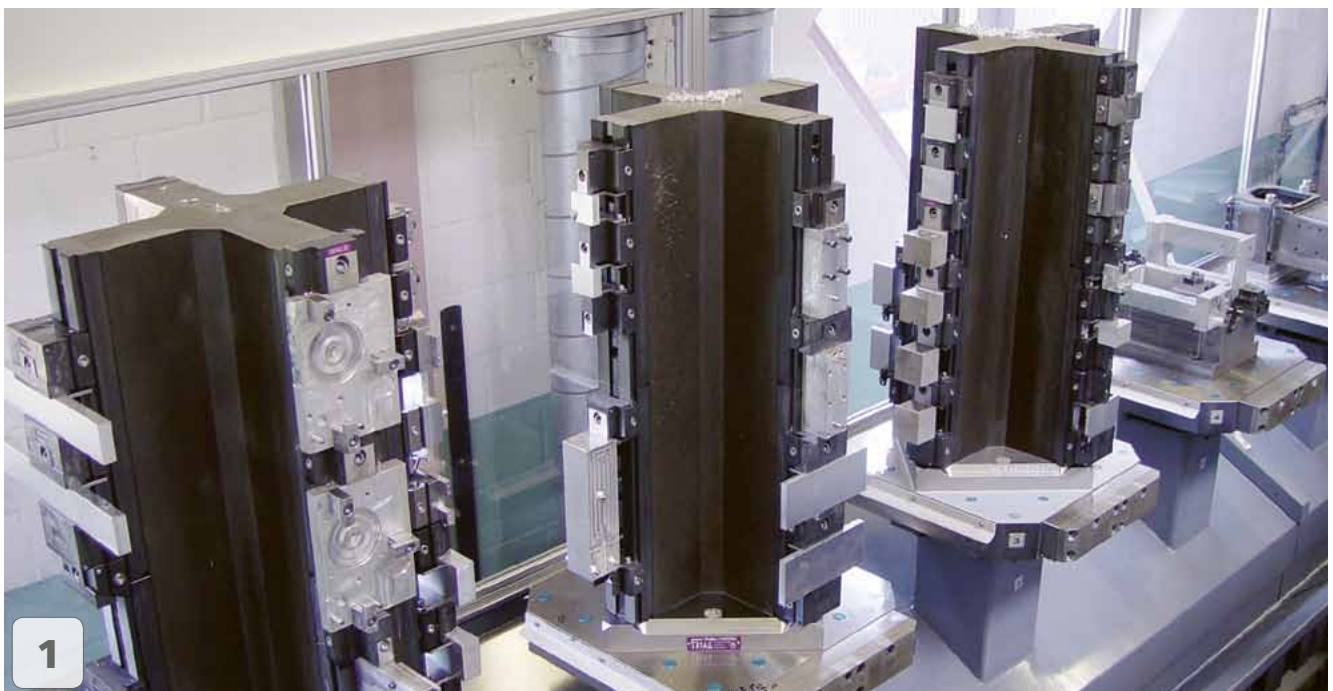
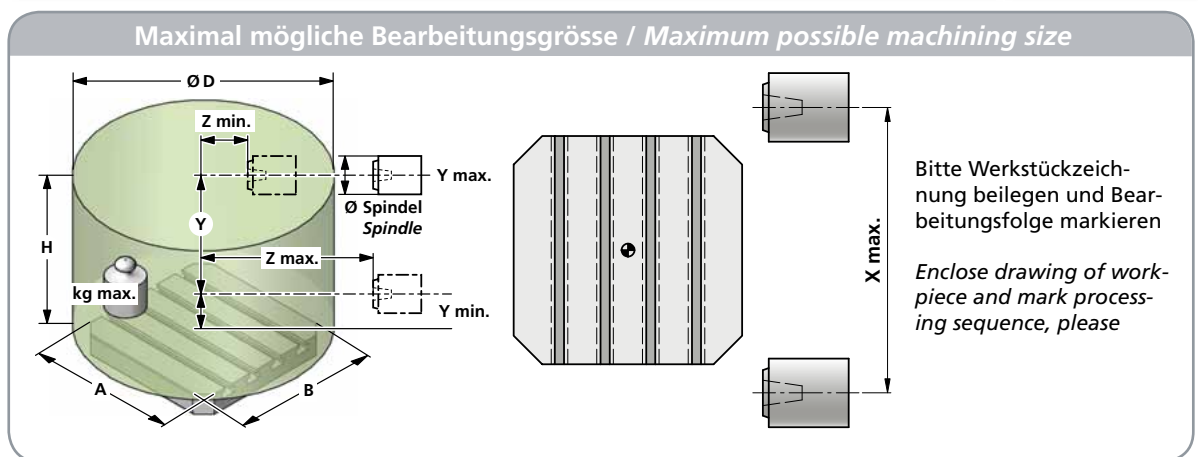



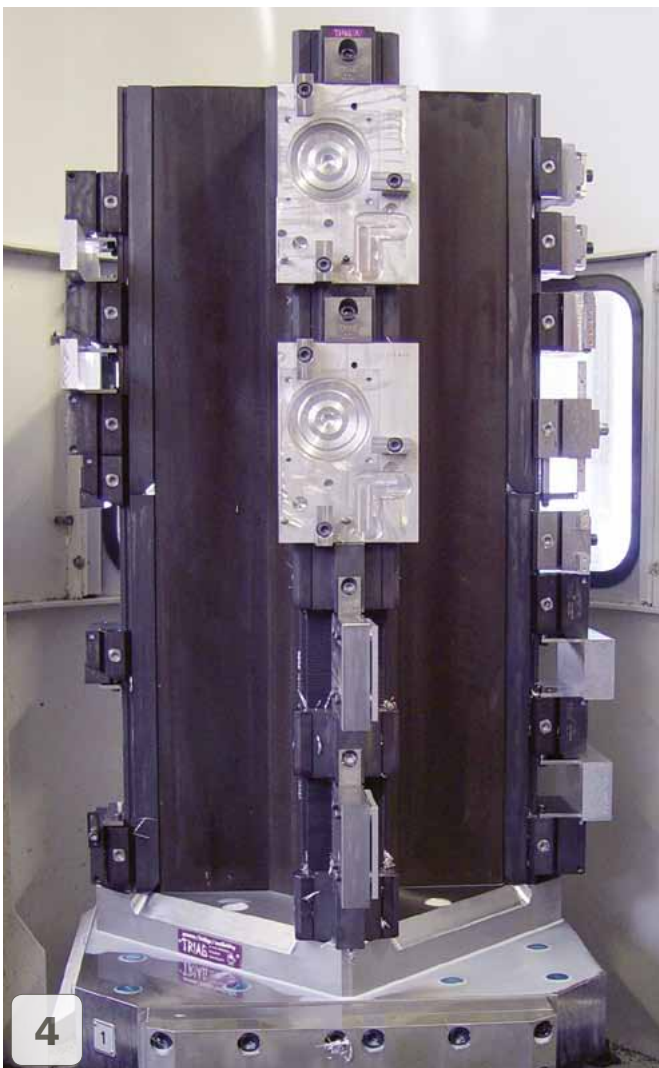
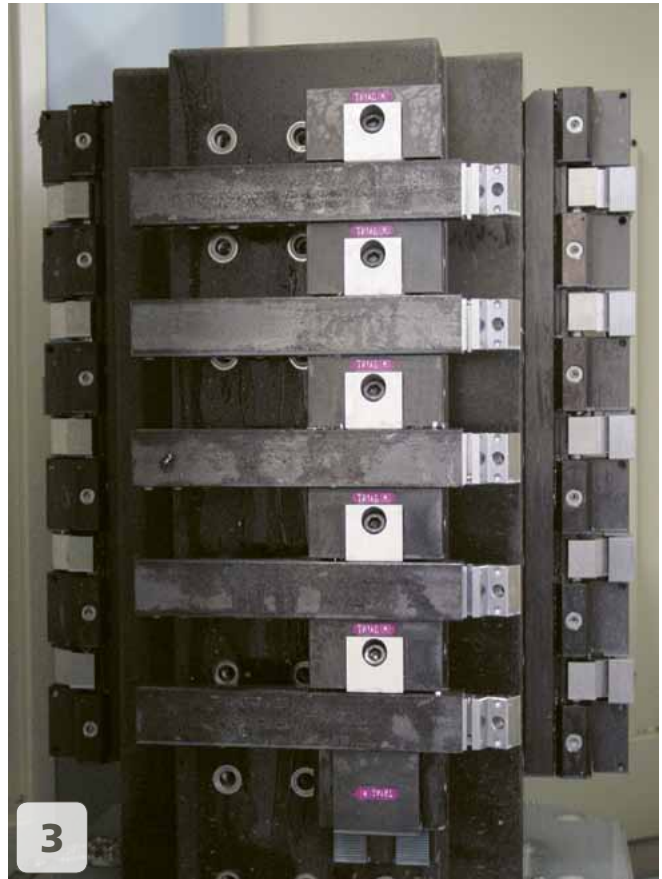

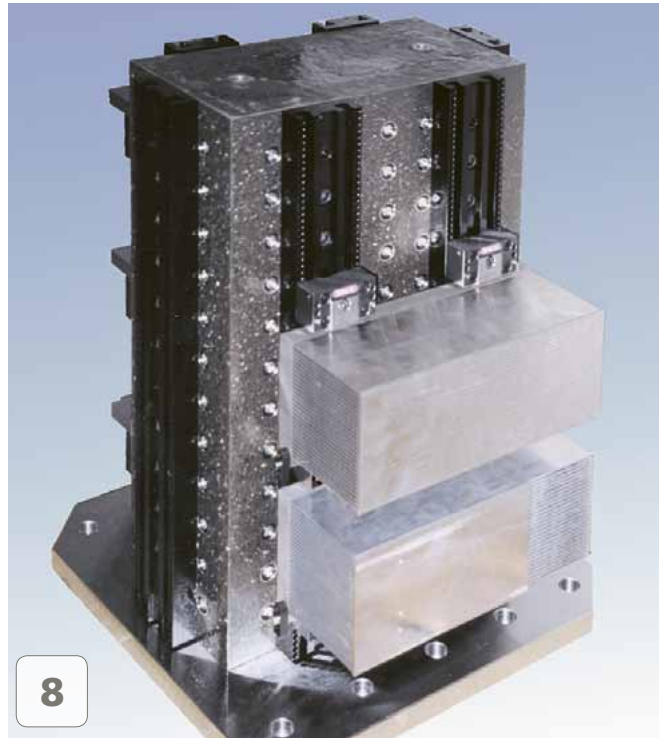

Stahl-Mineralguss Lösungen / Steel epoxy mineral tombstones solutions

SMK24-24-42 OPP200 ~ 120kg

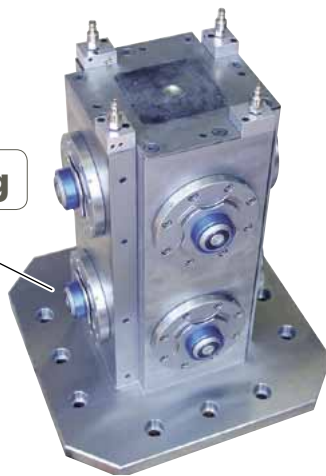

Pyramidenstumpf  
Truncated pyramid ~ 474kg

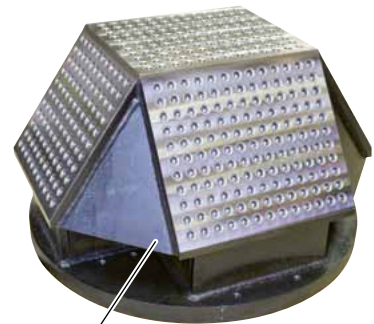

SMK30-17-42 OPP200 ~ 142kg

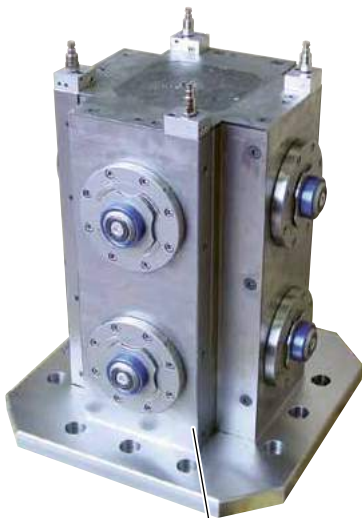





Turm-Material <i>Tombstone material</i>	
M	Mineralguss mit Stahldübel <i>Epoxy mineral with steel anchor</i>
SM	Stahl Mineralguss <i>Steel epoxy mineral tombstones</i>
G	Grauguss <i>Cast iron</i>

Grösste Schlüsselweite <i>Major width</i>	
12	120 mm
20	200 mm
24	240 mm
25	250 mm
30	300 mm
32	320 mm
35	350 mm
40	400 mm
42	420 mm
50	500 mm
60	600 mm
63	630 mm
70	700 mm

Höhe <i>Height</i>	
50	500 mm
55	550 mm
56	567 mm
60	600 mm
62	620 mm
65	650 mm
66	660 mm
70	700 mm
75	750 mm
80	800 mm
85	850 mm
90	900 mm
95	950 mm

**M**

**K**

**35**

**18**

**95**

**R50**

Modultyp <i>Type of module</i>	
K	Kreuz <i>Cross</i>
Q	Quadrat <i>Square</i>
R	Rechteck <i>Rectangular</i>
S	Sechseck <i>Hexagonal</i>
A	Achteck <i>Octagonal</i>
X	Spezialform <i>Special shape</i>

Aufspannbreite <i>Usable width</i>	
08	80 mm
09	90 mm
86	86 mm
10	100 mm
12	120 mm
15	150 mm
16	160 mm
18	180 mm
1808	180 / 80 mm
19	184 mm
20	200 mm
23	231 mm
24	240 mm
25	250 mm
30	300 mm
35	350 mm
40	400 mm
42	420 mm

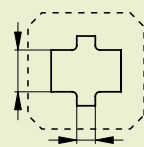

Raster <i>Grid</i>	
R40	40 mm
R50	50 mm
R80	80 mm
R100	100 mm
OPP	200 mm



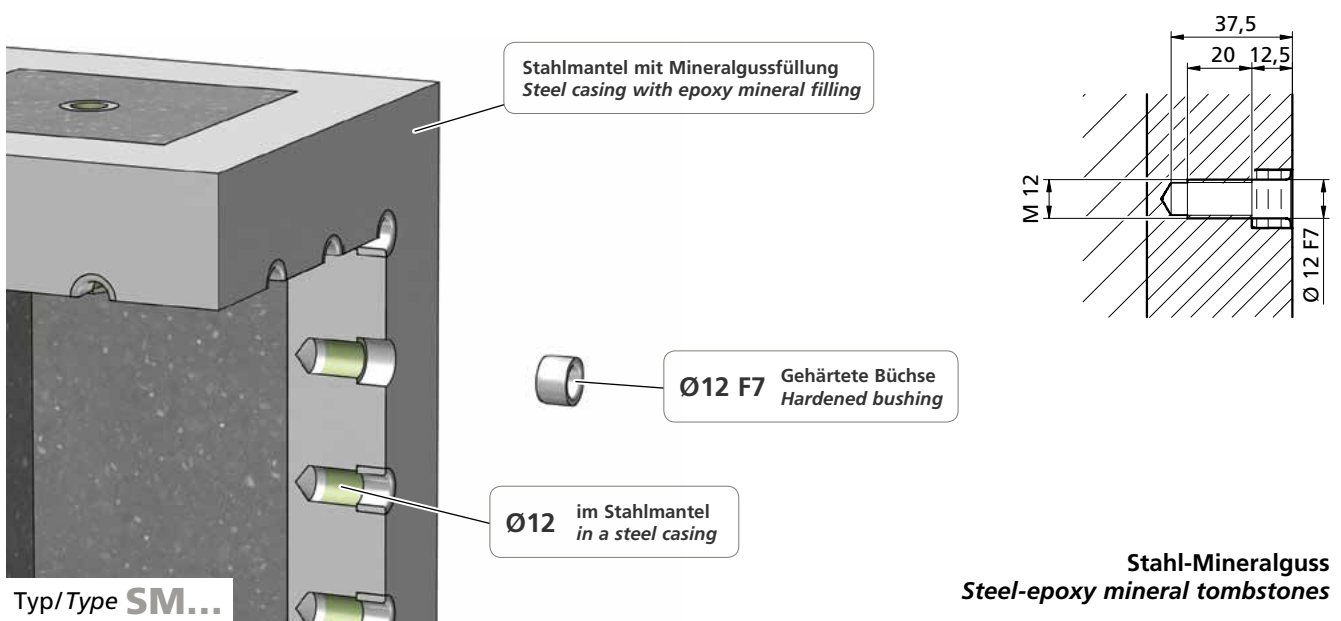
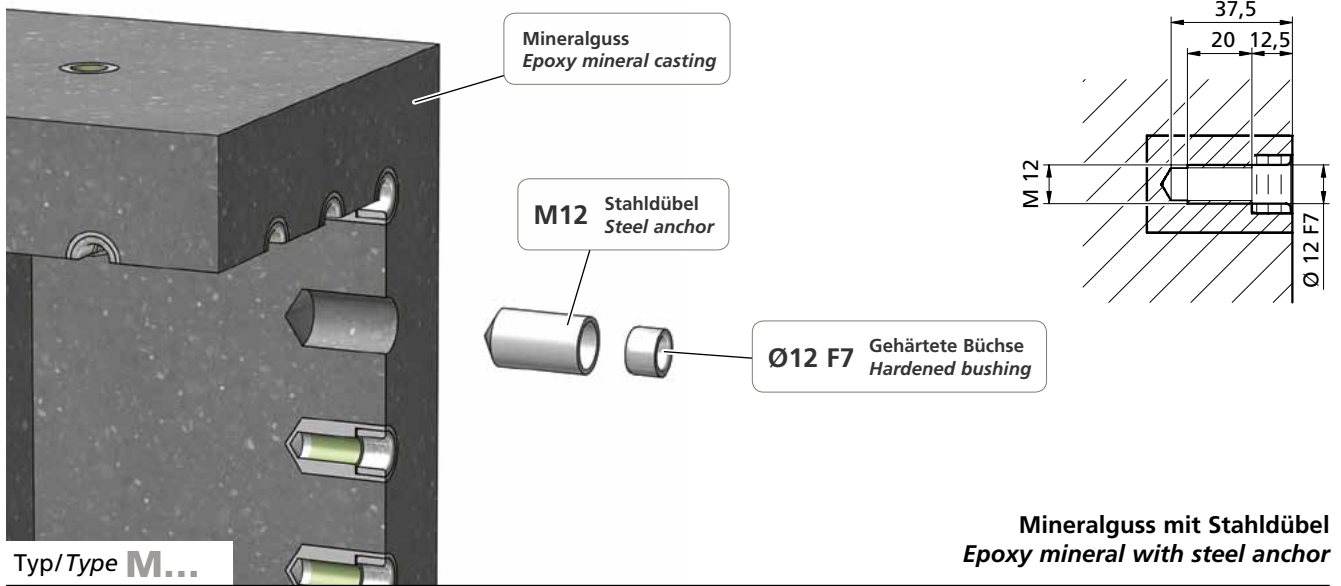

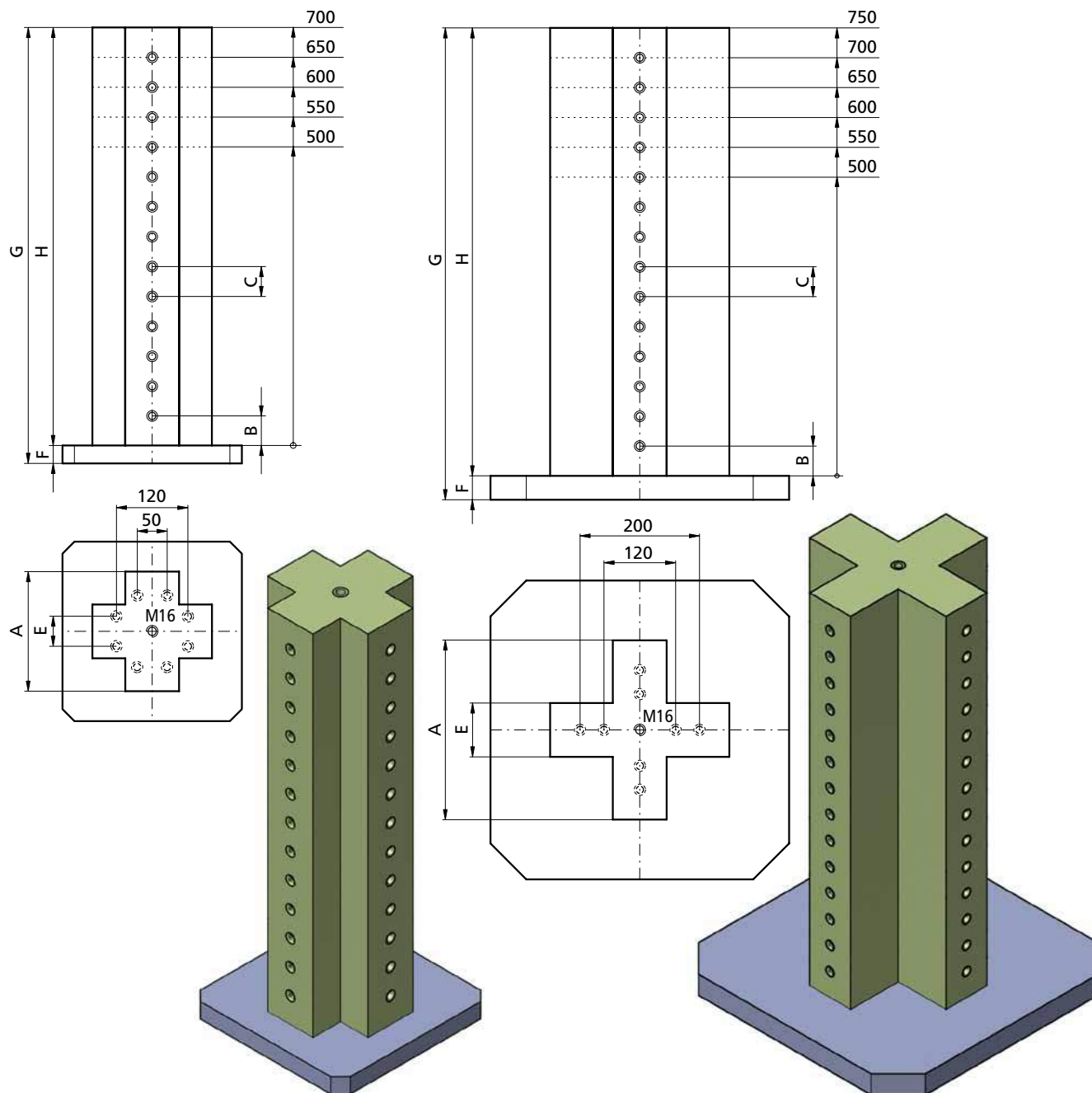

Mineralgussturm mit  
Stahldübel  
Epoxy Mineral with  
Steel Anchor

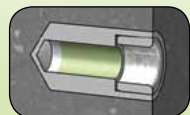

Seite / Page 250

Bestellbeispiel  
Ordering example: MK200965R50 &

p. 274

Grundplatte wird passend  
zu Ihrer Maschinenpalette  
hergestellt und muss separat  
bestellt werden!  
Base plate according to your  
machine configuration please  
order extra!

	kg*	A	B	C	E	F	G	H	Raster / Grid
MK200950R50	~38	200	50	50	90	(30)	(530)	500	36 x M12/12F7
MK200955R50	~42	200	50	50	90	(30)	(580)	550	40 x M12/12F7
MK200960R50	~45	200	50	50	90	(30)	(630)	600	44 x M12/12F7
MK200965R50	~49	200	50	50	90	(30)	(680)	650	48 x M12/12F7
MK200970R50	~53	200	50	50	90	(30)	(680)	650	48 x M12/12F7
MK300950R50	~60	300	50	50	90	(40)	(540)	500	36 x M12/12F7
MK300955R50	~66	300	50	50	90	(40)	(590)	550	40 x M12/12F7
MK300960R50	~72	300	50	50	90	(40)	(640)	600	44 x M12/12F7
MK300965R50	~78	300	50	50	90	(40)	(690)	650	48 x M12/12F7
MK300970R50	~84	300	50	50	90	(40)	(740)	700	52 x M12/12F7
MK300975R50	~90	300	50	50	90	(40)	(790)	750	56 x M12/12F7

\* Gewicht ohne Grundplatte! / Weight without baseplate!

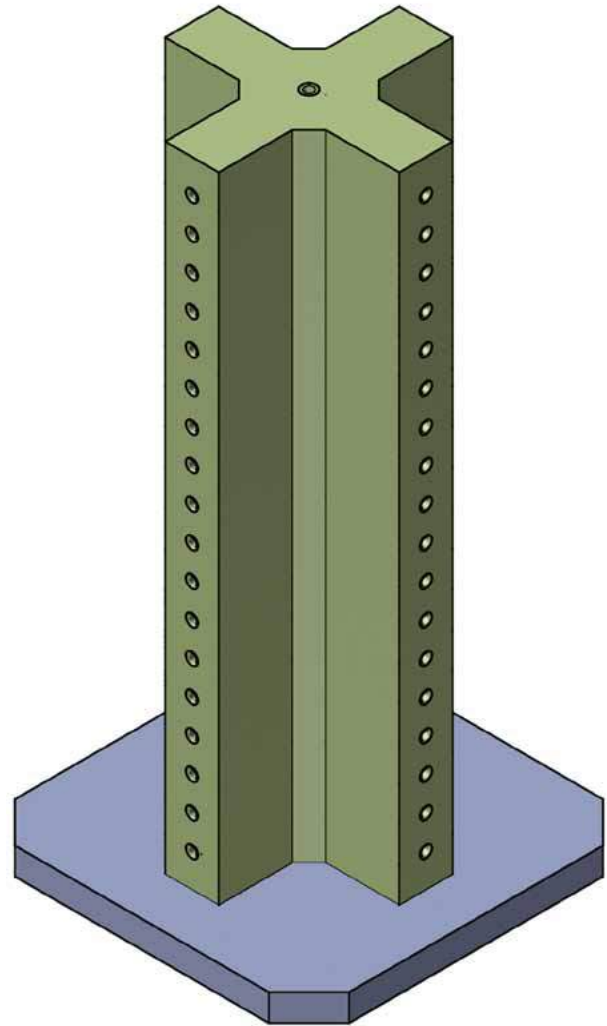
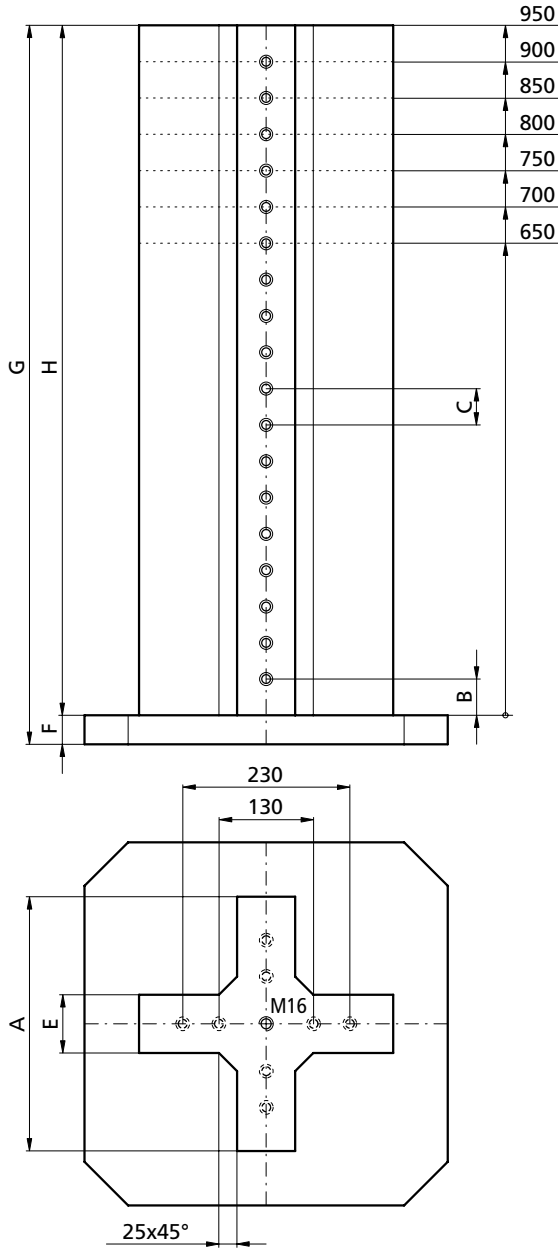

Grundplatte wird passend zu Ihrer Maschinenpalette hergestellt und muss separat bestellt werden!  
Base plate according to your machine configuration please order extra!

Mineralgussturm mit Stahldübel  
Epoxy Mineral with Steel Anchor

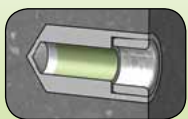

Seite / Page 250

Bestellbeispiel

Ordering example: MK350865R50 & p. 274

	kg*	A	B	C	E	F	G	H	Raster / Grid
MK350865R50	~85	350	50	50	80	(40)	(690)	<b>650</b>	48 x M12/12F7
MK350870R50	~92	350	50	50	80	(40)	(740)	<b>700</b>	52 x M12/12F7
MK350875R50	~99	350	50	50	80	(40)	(790)	<b>750</b>	56 x M12/12F7
MK350880R50	~105	350	50	50	80	(40)	(840)	<b>800</b>	60 x M12/12F7
MK350885R50	~112	350	50	50	80	(40)	(890)	<b>850</b>	64 x M12/12F7
MK350890R50	~118	350	50	50	80	(40)	(940)	<b>900</b>	68 x M12/12F7
MK350895R50	~125	350	50	50	80	(40)	(990)	<b>950</b>	72 x M12/12F7

\* Gewicht ohne Grundplatte! / Weight without baseplate!



MK3018 ... R50  
SMK3018 ... R50

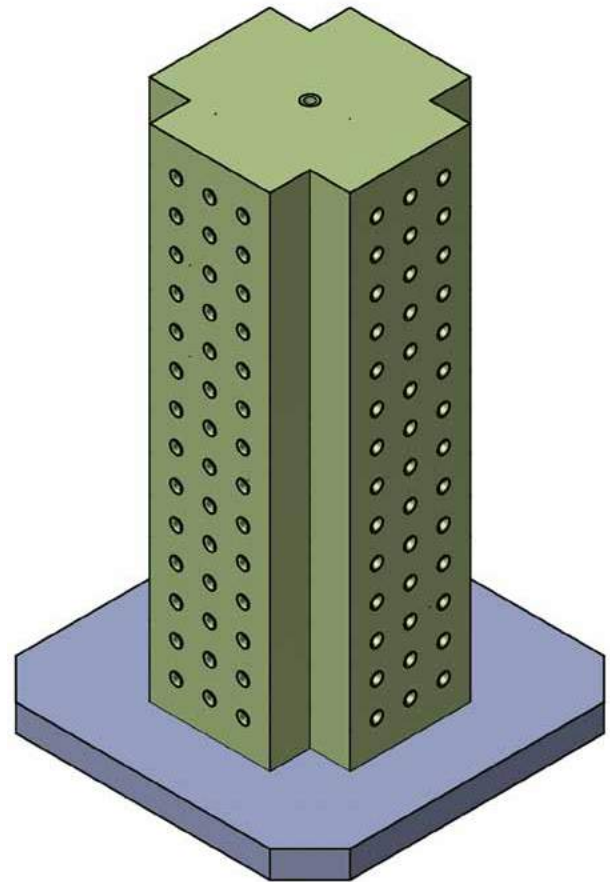
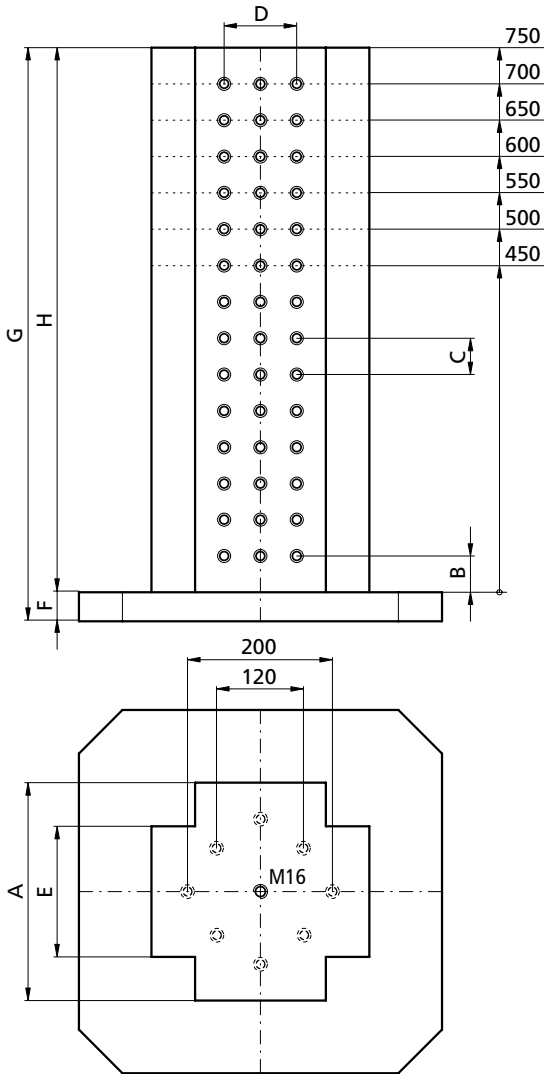

Grundplatte wird passend zu Ihrer Maschinenpalette hergestellt und muss separat bestellt werden!

Base plate according to your machine configuration please order extra!

Seite / Page 250

p. 274

Mineralgussturm mit  
Stahldübel  
Epoxy Mineral with  
Steel Anchor

Stahl-Mineralguss  
Steel-epoxy mineral  
tombstones

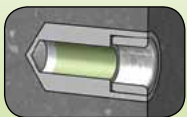

kg\*

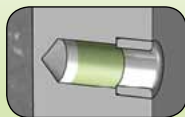

kg\*

Bestellbeispiel  
Ordering example: MK301850R50 &

				A	B	C	D	E	F	G	H	Raster / Grid
MK301845R50	~77	SMK301845R50	~100	300	50	50	100	180	(40)	(440)	450	96xM12/12F7
MK301850R50	~86	SMK301850R50	~110	300	50	50	100	180	(40)	(540)	500	108xM12/12F7
MK301855R50	~94	SMK301855R50	~120	300	50	50	100	180	(40)	(590)	550	120xM12/12F7
MK301860R50	~102	SMK301860R50	~132	300	50	50	100	180	(40)	(640)	600	132xM12/12F7
MK301865R50	~110	SMK301865R50	~141	300	50	50	100	180	(40)	(690)	650	144xM12/12F7
MK301870R50	~117	SMK301870R50	~152	300	50	50	100	180	(40)	(740)	700	156xM12/12F7
MK301875R50	~125	SMK301875R50	~162	300	50	50	100	180	(40)	(790)	750	168xM12/12F7

\* Gewicht ohne Grundplatte! / Weight without baseplate!



MK3210 ... R100

MK3218 ... R100

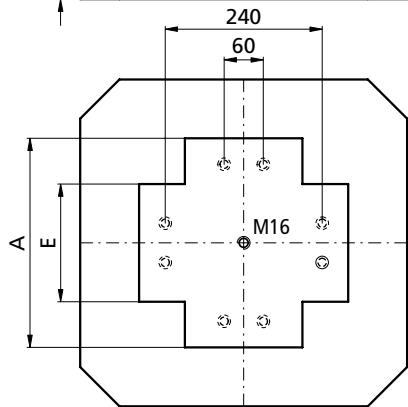
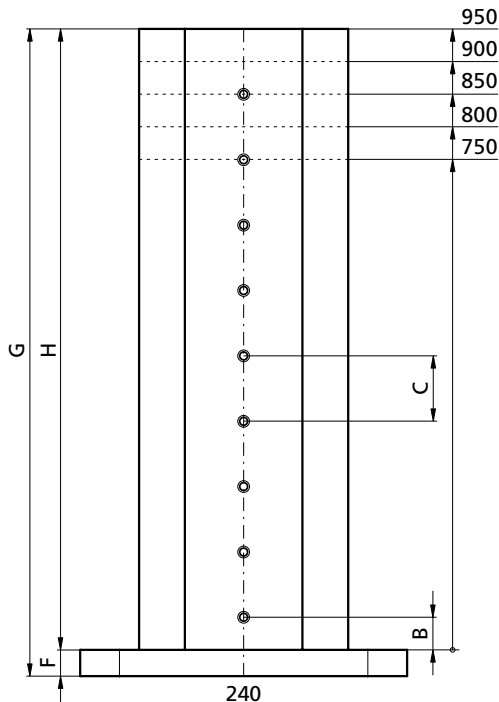

MK321895R100

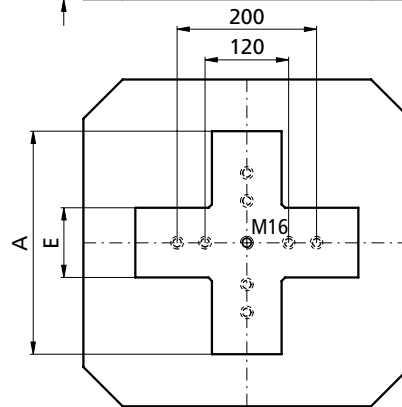
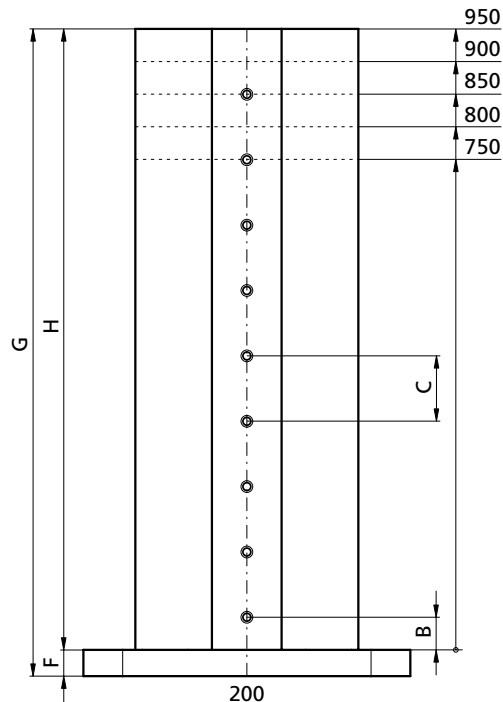
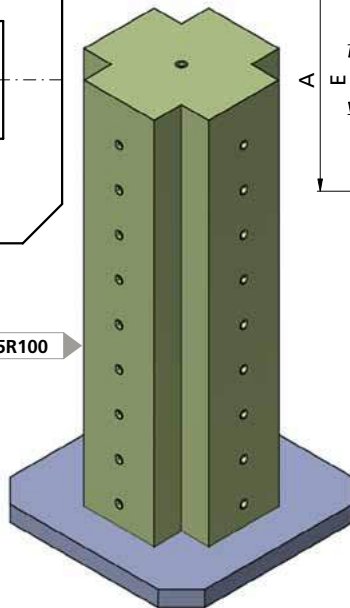

MK321095R100

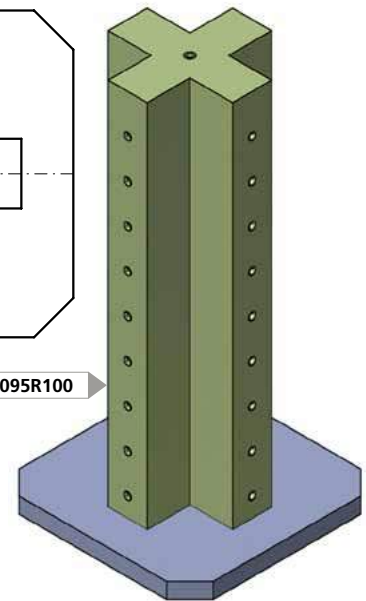

Grundplatte wird passend zu Ihrer Maschinenpalette hergestellt und muss separat bestellt werden!

Base plate according to your machine configuration please order extra!

Mineralgussturm mit  
Stahldübel  
Epoxy Mineral with  
Steel Anchor

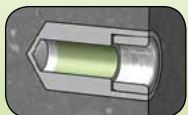

Seite / Page 250

Bestellbeispiel

Ordering example: MK321075R100 & p. 274

	kg*	A	B	C	E	F	G	H	Raster / Grid
MK321075R100	~101	320	50	100	100	(40)	(790)	<b>750</b>	20 x M12/12F7
MK321080R100	~108	320	50	100	100	(40)	(840)	<b>800</b>	24 x M12/12F7
MK321085R100	~115	320	50	100	100	(40)	(890)	<b>850</b>	28 x M12/12F7
MK321090R100	~121	320	50	100	100	(40)	(940)	<b>900</b>	32 x M12/12F7
MK321095R100	~128	320	50	100	100	(40)	(990)	<b>950</b>	36 x M12/12F7
MK321875R100	~106	320	50	100	180	(40)	(790)	<b>750</b>	20 x M12/12F7
MK321880R100	~116	320	50	100	180	(40)	(840)	<b>800</b>	24 x M12/12F7
MK321885R100	~126	320	50	100	180	(40)	(890)	<b>850</b>	28 x M12/12F7
MK321890R100	~135	320	50	100	180	(40)	(940)	<b>900</b>	32 x M12/12F7
MK321895R100	~145	320	50	100	180	(40)	(990)	<b>950</b>	36 x M12/12F7

MK3518 ... R50  
SMK3518 ... R50

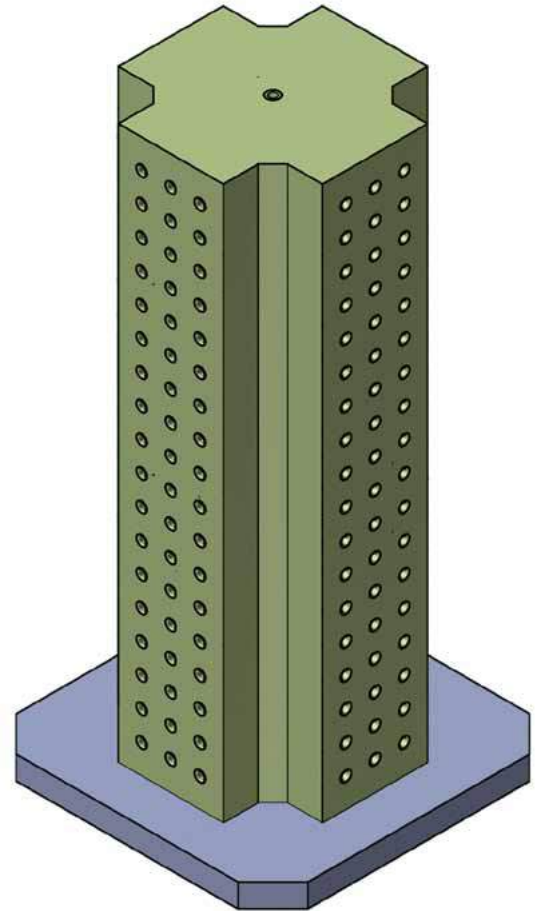
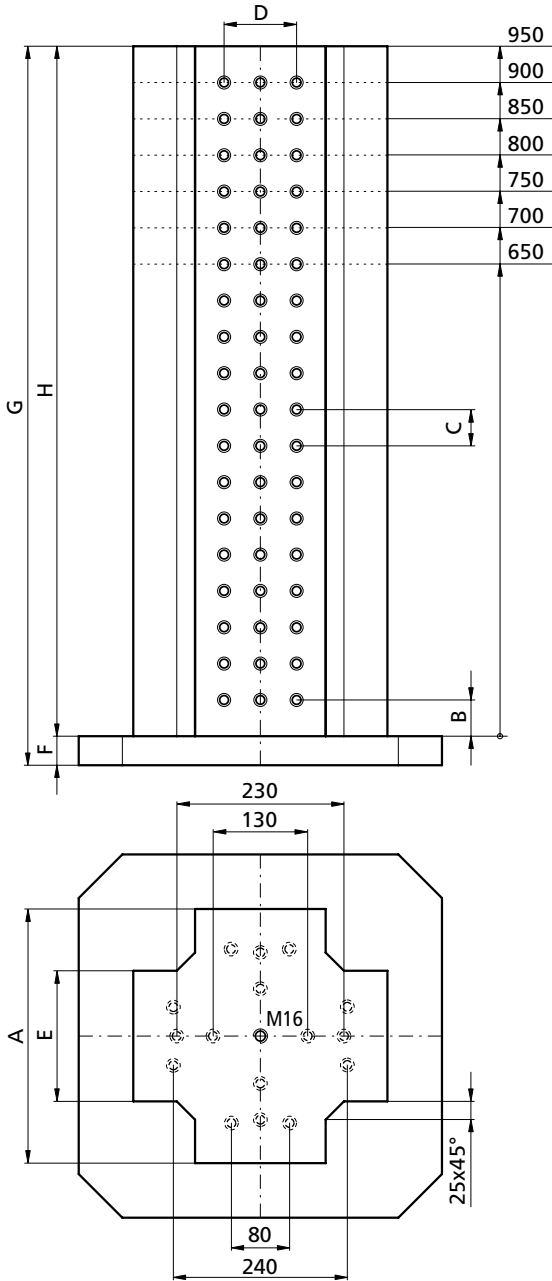

Grundplatte wird passend zu Ihrer Maschinenpalette hergestellt und muss separat bestellt werden!  
Base plate according to your machine configuration please order extra!

p. 274

Mineralgussturm mit  
Stahldübel  
Epoxy Mineral with  
Steel Anchor

Stahl-Mineralguss  
Steel-epoxy mineral  
tombstones

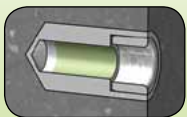

kg\*

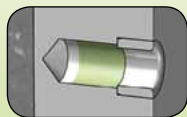

kg\*

Seite / Page 250

Bestellbeispiel  
Ordering example: **MK351865R50** &

					A	B	C	D	E	F	G	H	Raster / Grid
MK351865R50	~134	SMK351865R50	~165		350	50	50	100	180	(40)	(690)	<b>650</b>	144 x M12/12F7
MK351870R50	~144	SMK351870R50	~180		350	50	50	100	180	(40)	(740)	<b>700</b>	156 x M12/12F7
MK351875R50	~153	SMK351875R50	~190		350	50	50	100	180	(40)	(790)	<b>750</b>	168 x M12/12F7
MK351880R50	~163	SMK351880R50	~205		350	50	50	100	180	(40)	(840)	<b>800</b>	180 x M12/12F7
MK351885R50	~172	SMK351885R50	~215		350	50	50	100	180	(40)	(890)	<b>850</b>	192 x M12/12F7
MK351890R50	~182	SMK351890R50	~230		350	50	50	100	180	(40)	(940)	<b>900</b>	204 x M12/12F7
MK351895R50	~191	SMK351895R50	~240		350	50	50	100	180	(40)	(990)	<b>950</b>	216 x M12/12F7

\* Gewicht ohne Grundplatte! / Weight without baseplate!



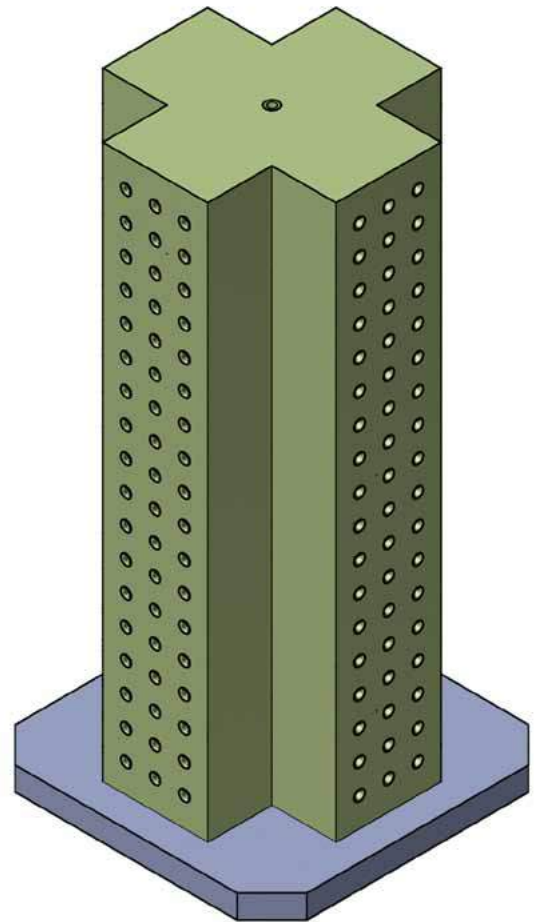
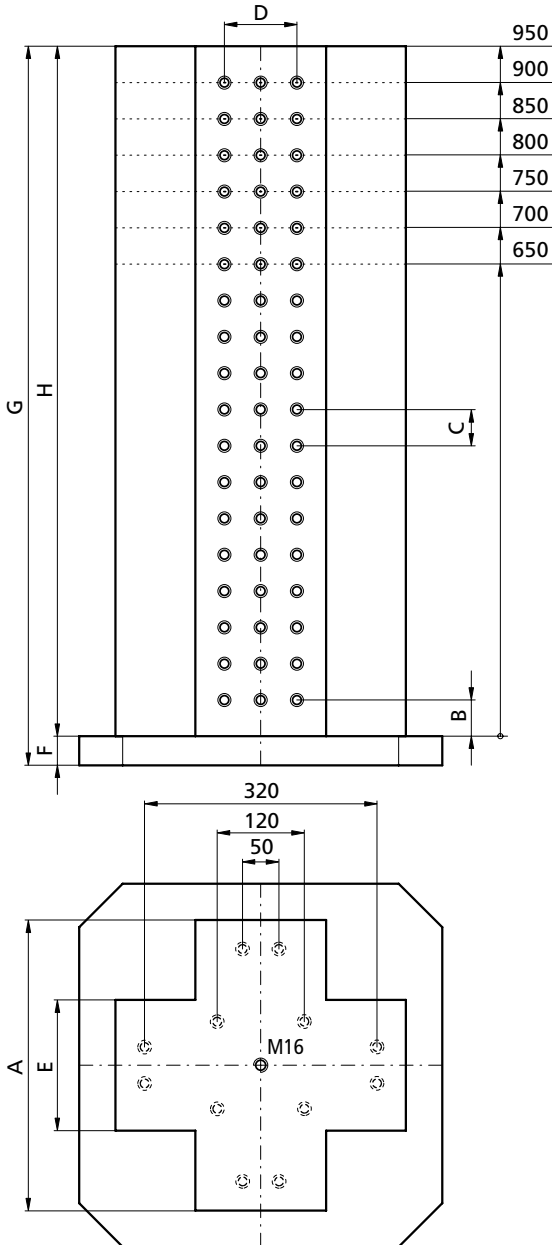

Grundplatte wird passend zu Ihrer Maschinenpalette hergestellt und muss separat bestellt werden!  
Base plate according to your machine configuration please order extra!

p. 274

Mineralgussturm mit  
Stahldübel  
Epoxy Mineral with  
Steel Anchor

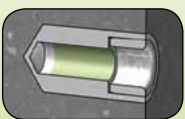

Seite / Page 250

Bestellbeispiel  
Ordering example: MK401865R50 &

	kg*	A	B	C	D	E	F	G	H	Raster / Grid
MK401865R50	~161	400	50	50	100	180	(40)	(690)	650	144 x M12/12F7
MK401870R50	~172	400	50	50	100	180	(40)	(740)	700	156 x M12/12F7
MK401875R50	~184	400	50	50	100	180	(40)	(790)	750	168 x M12/12F7
MK401880R50	~195	400	50	50	100	180	(40)	(840)	800	180 x M12/12F7
MK401885R50	~207	400	50	50	100	180	(40)	(890)	850	192 x M12/12F7
MK401890R50	~218	400	50	50	100	180	(40)	(940)	900	204 x M12/12F7
MK401895R50	~230	400	50	50	100	180	(40)	(990)	950	216 x M12/12F7



MQ1616_R50	kg	Raster / Grid	A	C	H	SCAN OR CLICK
<b>MQ161630R50</b>	~19	20 x M12/12F7	160	50	300	 ZEICHNUNG DRAWING STEP-DATEI STEP-FILE
<b>MQ161635R50</b>	~22	24 x M12/12F7	160	50	350	
<b>MQ161640R50</b>	~25	28 x M12/12F7	160	50	400	
<b>MQ161645R50</b>	~28	32 x M12/12F7	160	50	450	
<b>MQ161650R50</b>	~31	36 x M12/12F7	160	50	500	

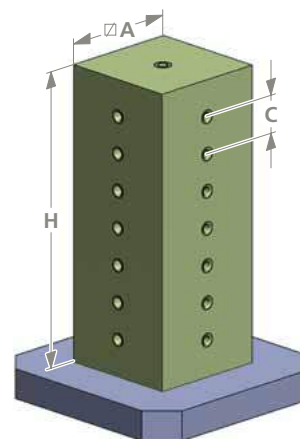

Maschienschonend und leicht,  
fast in allen Formen herstellbar

*Reduces machine wear due to low  
specific weight - can be produced  
in all sorts of shapes*

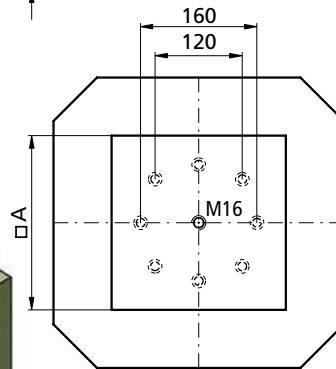
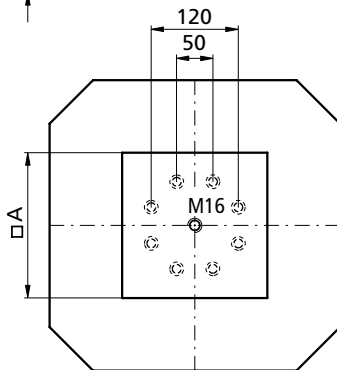
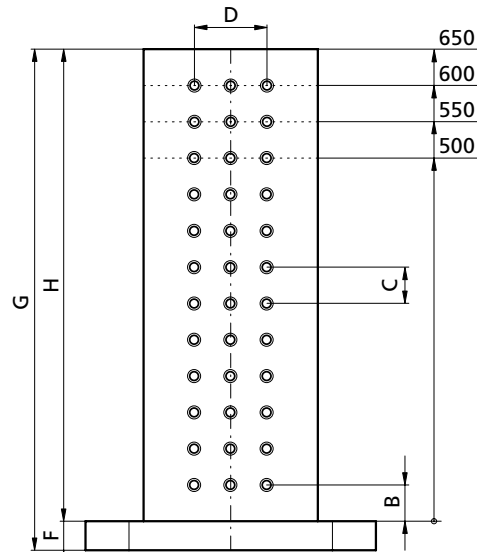
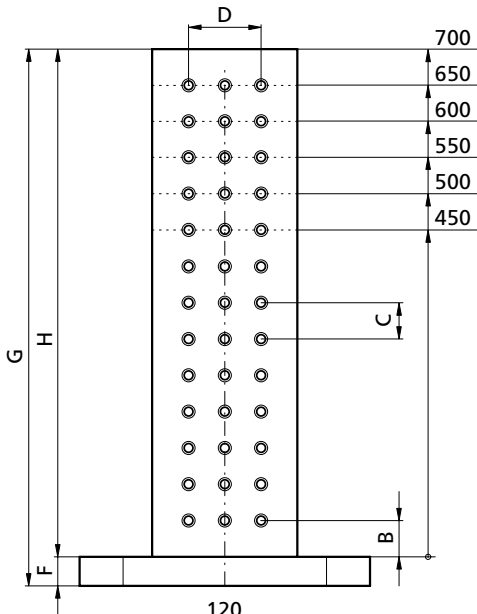

MQ202070R50

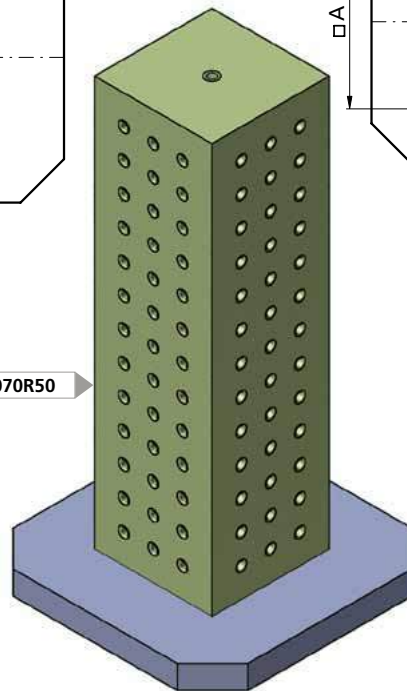

MQ242465R50

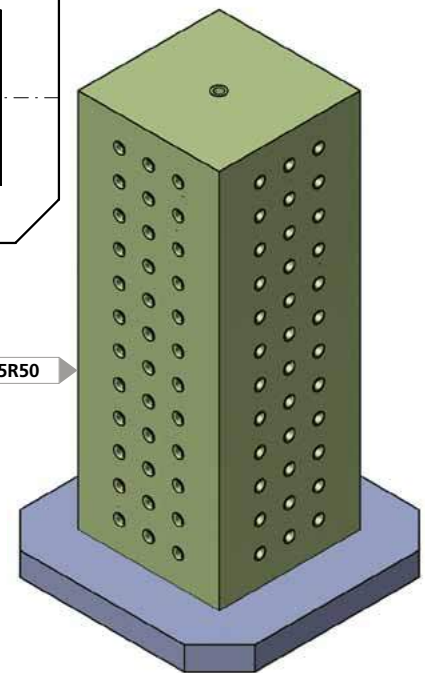

Grundplatte wird passend zu Ihrer Maschinenpalette hergestellt und muss separat bestellt werden!  
Base plate according to your machine configuration please order extra!

Mineralgussturm mit  
Stahldübel  
Epoxy Mineral with  
Steel Anchor

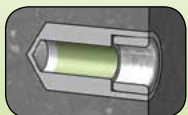

Seite / Page 250

Bestellbeispiel  
Ordering example: MQ202045R50 & p. 274

	kg*	A	B	C	D	F	G	H	Raster / Grid
MQ202045R50	~53	200	50	50	100	(40)	(490)	450	96 x M12/12F7
MQ202050R50	~59	200	50	50	100	(40)	(540)	500	108 x M12/12F7
MQ202055R50	~64	200	50	50	100	(40)	(590)	550	120 x M12/12F7
MQ202060R50	~70	200	50	50	100	(40)	(640)	600	132 x M12/12F7
MQ202065R50	~76	200	50	50	100	(40)	(690)	650	144 x M12/12F7
MQ202070R50	~81	200	50	50	100	(40)	(740)	700	156 x M12/12F7
MQ242450R50	~81	240	50	50	100	(40)	(540)	500	108 x M12/12F7
MQ242455R50	~89	240	50	50	100	(40)	(590)	550	120 x M12/12F7
MQ242460R50	~97	240	50	50	100	(40)	(640)	600	132 x M12/12F7
MQ242465R50	~103	240	50	50	100	(40)	(690)	650	144 x M12/12F7



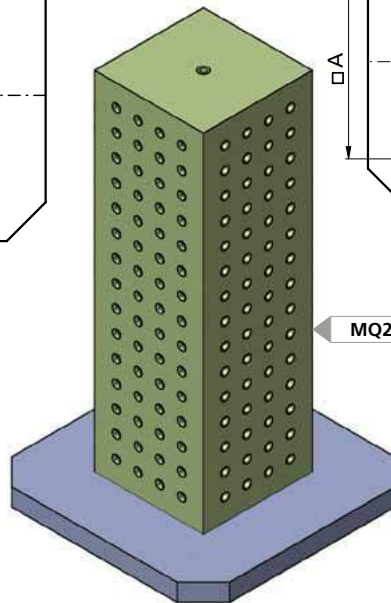
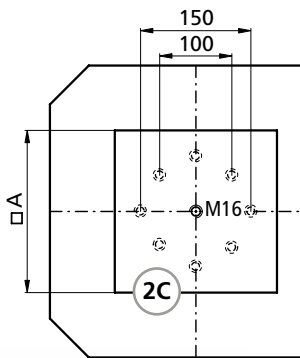
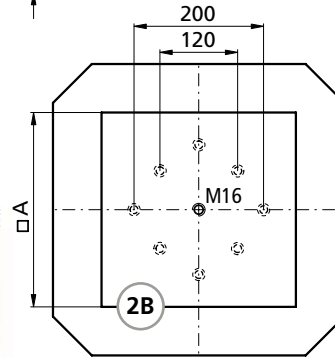
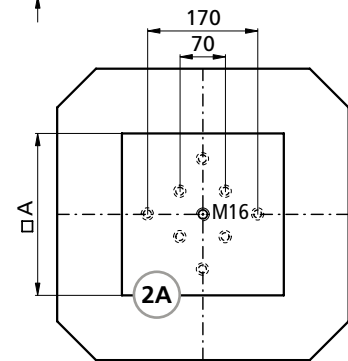
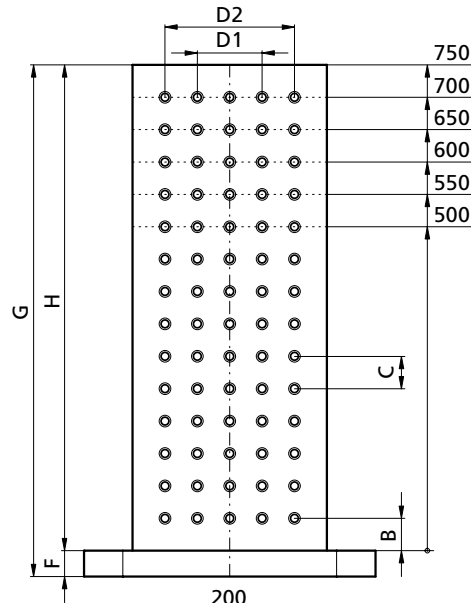
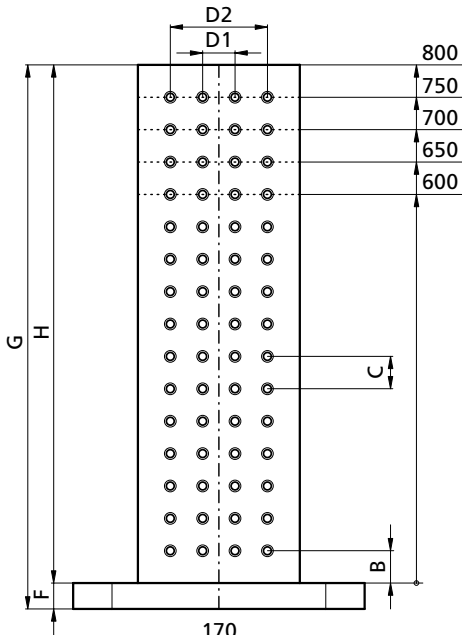

MQ303075R50

MQ252580R50

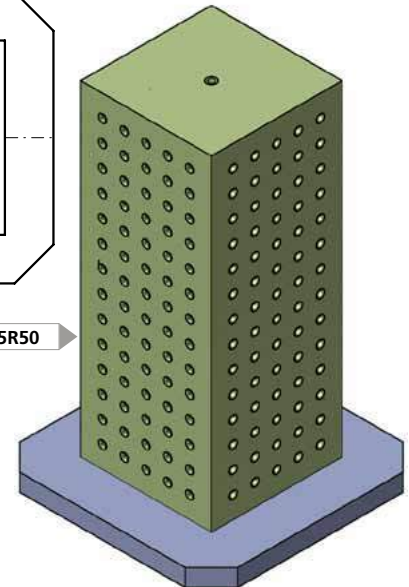

Grundplatte wird passend zu Ihrer Maschinenpalette hergestellt und muss separat bestellt werden!  
Base plate according to your machine configuration please order extra!

p. 274

Mineralgussturm mit  
Stahldübel

Epoxy Mineral with  
Steel Anchor

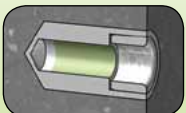

Seite / Page 250

Bestellbeispiel  
Ordering example: MQ252560R50 &

	kg*	Bohrbild Hole pattern	A	B	C	D1	D2	F	G	H	Raster / Grid
MQ252560R50	~107	2A	250	50	50	100	150	(40)	(640)	600	176 x M12/12F7
MQ252565R50	~116	2A	250	50	50	100	150	(40)	(690)	650	192 x M12/12F7
MQ252570R50	~125	2A	250	50	50	100	150	(40)	(740)	700	208 x M12/12F7
MQ252575R50	~134	2C	250	50	50	100	150	(40)	(790)	750	224 x M12/12F7
MQ252580R50	~143	2C	250	50	50	100	150	(40)	(840)	800	240 x M12/12F7
MQ303050R50	~109	2B	300	50	50	100	200	(40)	(540)	500	180 x M12/12F7
MQ303055R50	~119	2B	300	50	50	100	200	(40)	(590)	550	200 x M12/12F7
MQ303060R50	~129	2B	300	50	50	100	200	(40)	(640)	600	220 x M12/12F7
MQ303065R50	~139	2B	300	50	50	100	200	(40)	(690)	650	240 x M12/12F7
MQ303070R50	~149	2B	300	50	50	100	200	(40)	(740)	700	260 x M12/12F7
MQ303075R50	~162	2B	300	50	50	100	200	(40)	(790)	750	280 x M12/12F7

\* Gewicht ohne Grundplatte! / Weight without baseplate!

**MQ4040 ... R50**  
**MQ3535 ... R50**

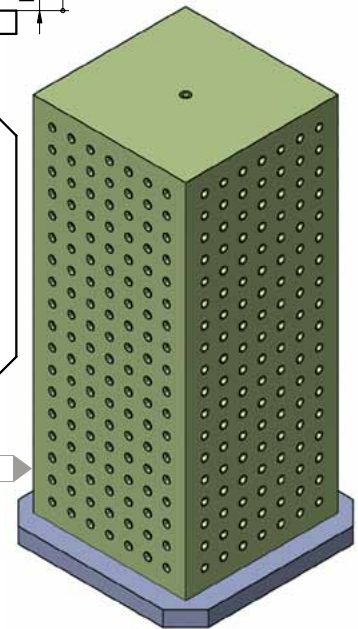
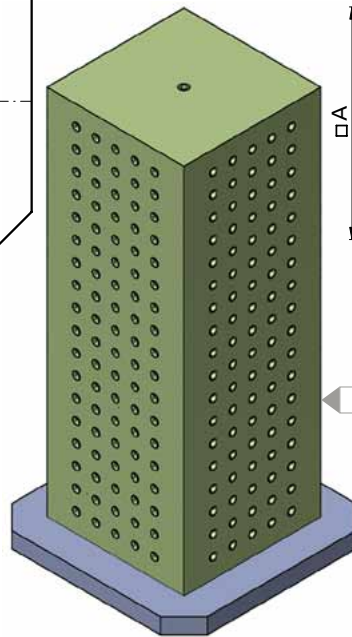
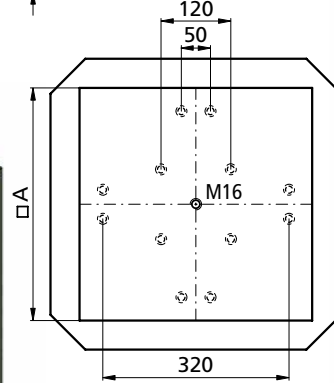
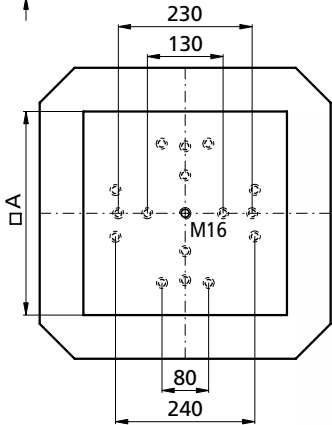
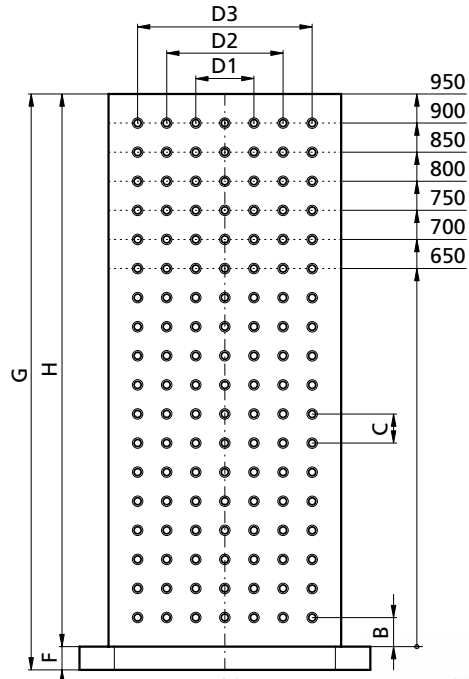
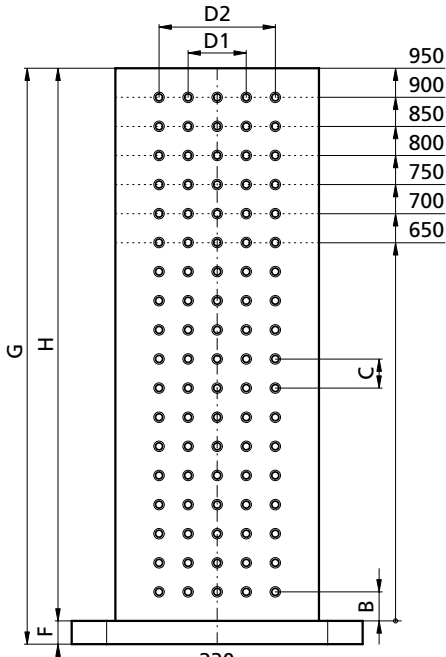

Mineralgussturm mit  
Stahldübel  
Epoxy Mineral with  
Steel Anchor

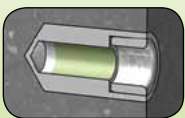

Seite / Page 250

Bestellbeispiel

Ordering example: **MQ353565R50** &

p. 274

Grundplatte wird passend  
zu Ihrer Maschinenpalette  
hergestellt und muss separat  
bestellt werden!

Base plate according to your  
machine configuration please  
order extra!

	kg*	A	B	C	D1	D2	D3	F	G	H	Raster / Grid
MQ353565R50	~175	350	50	50	100	200		(40)	(690)	<b>650</b>	240 x M12/12F7
MQ353570R50	~187	350	50	50	100	200		(40)	(740)	<b>700</b>	260 x M12/12F7
MQ353575R50	~200	350	50	50	100	200		(40)	(790)	<b>750</b>	280 x M12/12F7
MQ353580R50	~213	350	50	50	100	200		(40)	(840)	<b>800</b>	300 x M12/12F7
MQ353585R50	~225	350	50	50	100	200		(40)	(890)	<b>850</b>	320 x M12/12F7
MQ353590R50	~238	350	50	50	100	200		(40)	(940)	<b>900</b>	340 x M12/12F7
MQ353595R50	~250	350	50	50	100	200		(40)	(990)	<b>950</b>	360 x M12/12F7
MQ404065R50	~217	400	50	50	100	200	300	(40)	(690)	<b>650</b>	336 x M12/12F7
MQ404070R50	~232	400	50	50	100	200	300	(40)	(740)	<b>700</b>	364 x M12/12F7
MQ404075R50	~247	400	50	50	100	200	300	(40)	(790)	<b>750</b>	392 x M12/12F7
MQ404080R50	~262	400	50	50	100	200	300	(40)	(840)	<b>800</b>	420 x M12/12F7
MQ404085R50	~277	400	50	50	100	200	300	(40)	(890)	<b>850</b>	448 x M12/12F7
MQ404090R50	~292	400	50	50	100	200	300	(40)	(940)	<b>900</b>	476 x M12/12F7
MQ404095R50	~307	400	50	50	100	200	300	(40)	(990)	<b>950</b>	504 x M12/12F7



MQ4242 ... R40

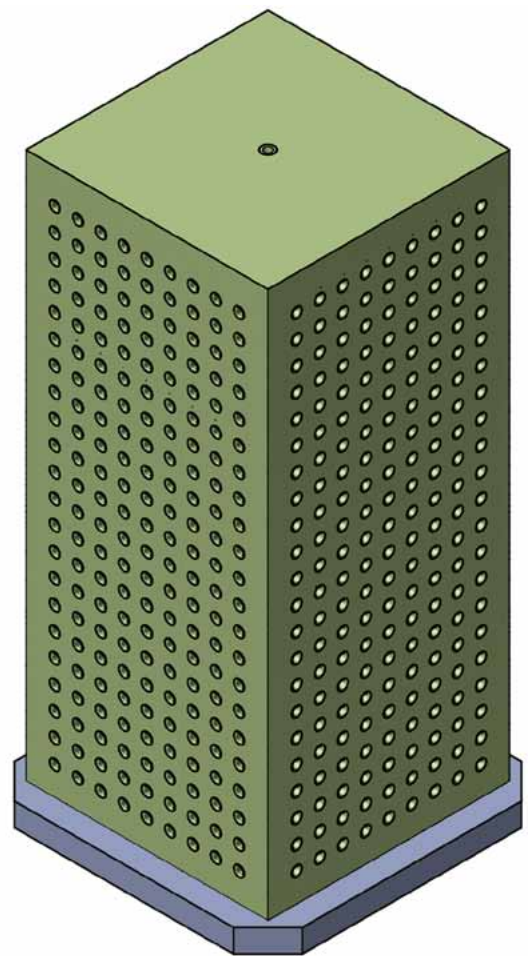
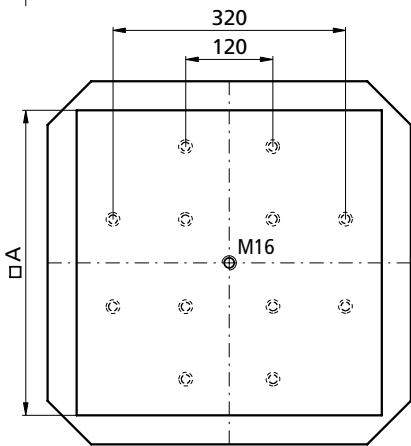
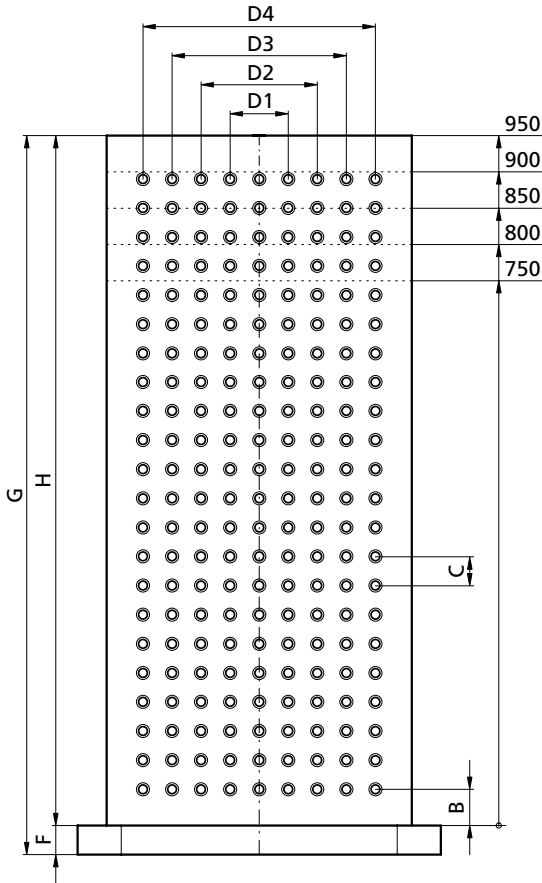

Grundplatte wird passend zu Ihrer Maschinenpalette hergestellt und muss separat bestellt werden!  
*Base plate according to your machine configuration please order extra!*

Mineralgussturm mit Stahldübel  
*Epoxy Mineral with Steel Anchor*

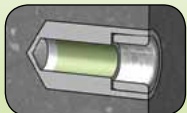

Seite / Page 250

Bestellbeispiel  
Ordering example: **MQ424275R40** & \_\_\_\_\_ p. 274

	kg*	A	B	C	D1	D2	D3	D4	F	G	H	Raster / Grid
MQ424275R40	~329	420	50	40	80	160	240	320	(40)	(790)	<b>750</b>	612 x M12/12F7
MQ424280R40	~349	420	50	40	80	160	240	320	(40)	(840)	<b>800</b>	648 x M12/12F7
MQ424285R40	~373	420	50	40	80	160	240	320	(40)	(890)	<b>850</b>	684 x M12/12F7
MQ424290R40	~393	420	50	40	80	160	240	320	(40)	(940)	<b>900</b>	720 x M12/12F7
MQ424295R40	~413	420	50	40	80	160	240	320	(40)	(990)	<b>950</b>	756 x M12/12F7

\* Gewicht ohne Grundplatte! / Weight without baseplate!

Separat bestellen / Separate order



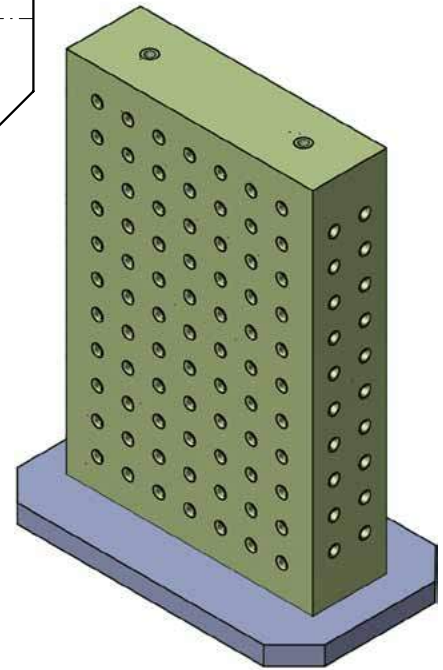
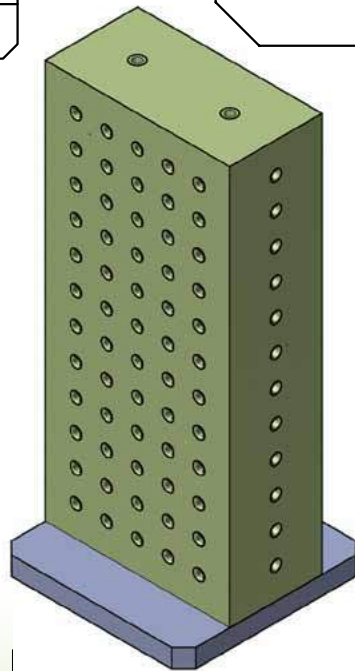
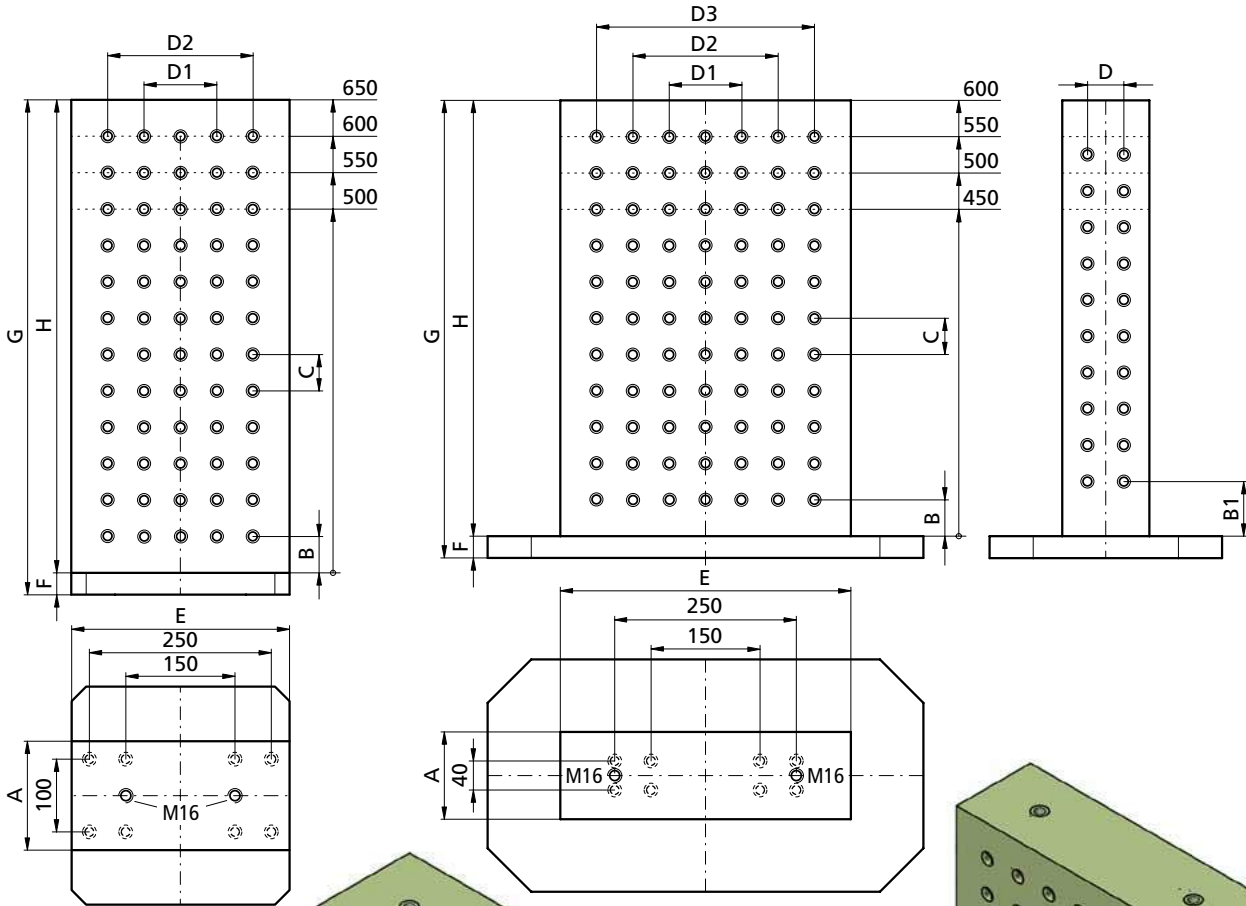
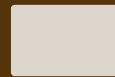

Mineralgussturm mit  
Stahldübel  
Epoxy Mineral with  
Steel Anchor

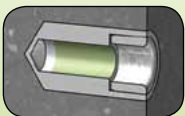

Seite / Page 250

Bestellbeispiel

Ordering example: MR401245R50 &

p. 274

Grundplatte wird passend  
zu Ihrer Maschinenpalette  
hergestellt und muss separat  
bestellt werden!  
Base plate according to your  
machine configuration please  
order extra!

	kg*	A	B	B1	C	D	D1	D2	D3	E	F	G	H	Raster / Grid
MR301550R50	~65	150	50		50		100	200		300	(30)	(530)	500	63 x M12/12F7
MR301555R50	~72	150	50		50		100	200		300	(30)	(580)	550	70 x M12/12F7
MR301560R50	~78	150	50		50		100	200		300	(30)	(630)	600	77 x M12/12F7
MR301565R50	~85	150	50		50		100	200		300	(30)	(680)	650	84 x M12/12F7
MR401245R50	~64	120	50	75	50	50	100	200	300	400	(30)	(480)	450	140 x M12/12F7
MR401250R50	~71	120	50	75	50	50	100	200	300	400	(30)	(530)	500	158 x M12/12F7
MR401255R50	~78	120	50	75	50	50	100	200	300	400	(30)	(580)	550	176 x M12/12F7
MR401260R50	~85	120	50	75	50	50	100	200	300	400	(30)	(630)	600	194 x M12/12F7

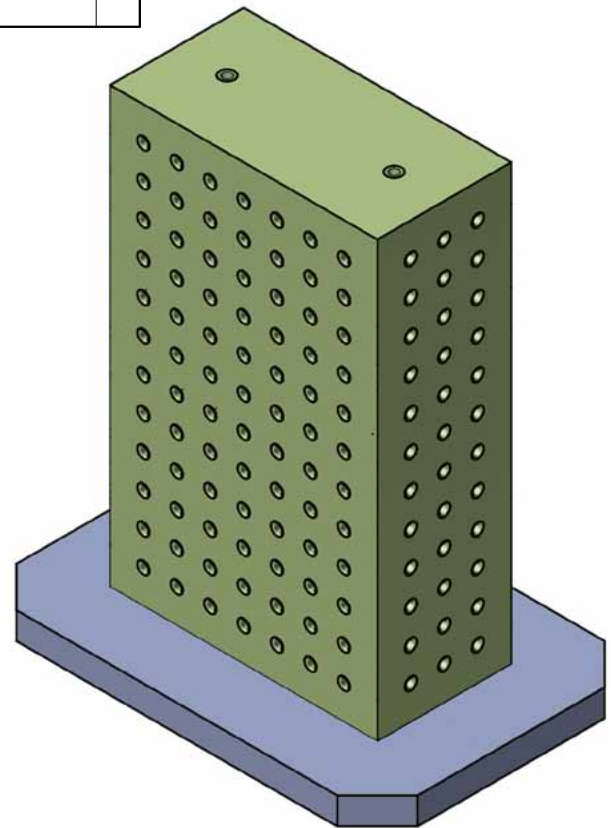
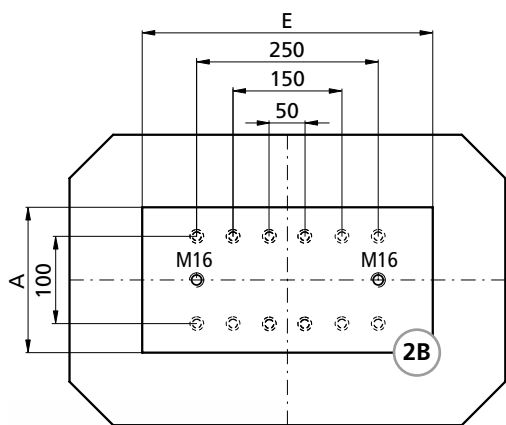
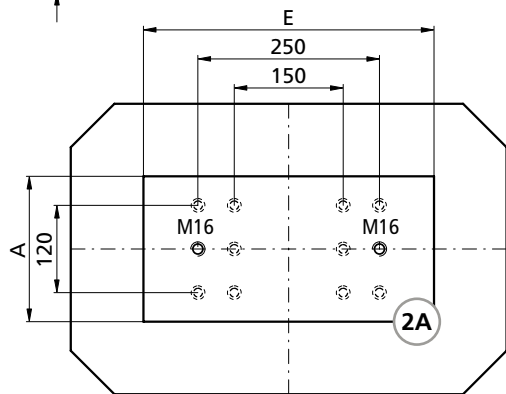
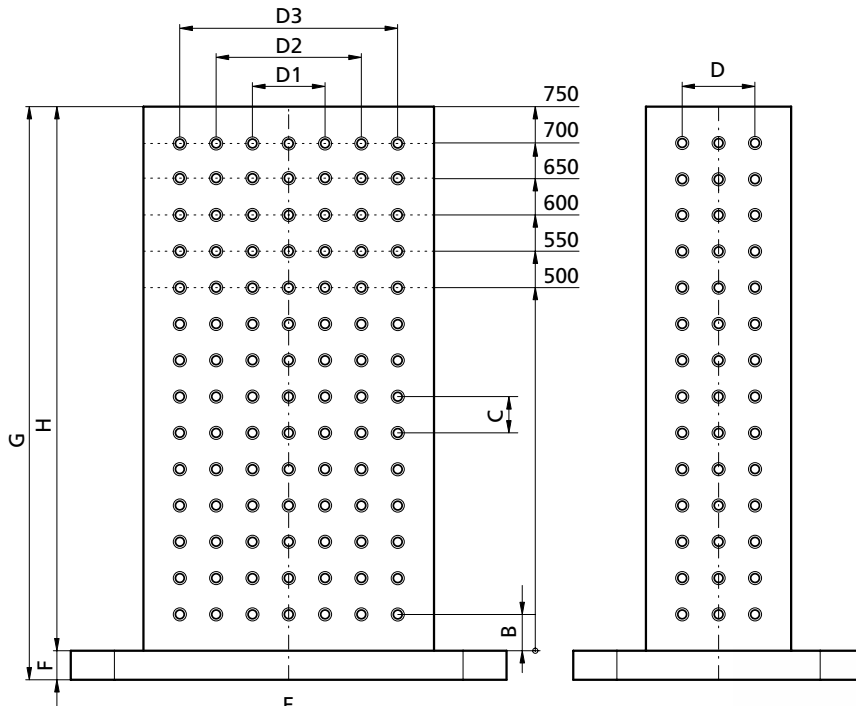

Grundplatte wird passend zu Ihrer Maschinenpalette hergestellt und muss separat bestellt werden!  
Base plate according to your machine configuration please order extra!

Mineralgussturm mit Stahldübel  
Epoxy Mineral with Steel Anchor

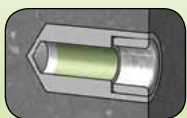

Seite / Page 250

Bestellbeispiel  
Ordering example: MR402050R50 & \_\_\_\_\_ p. 274

	kg*	Bohrbild / Hole pattern	A	B	C	D	D1	D2	D3	E	F	G	H	Raster / Grid
MR402050R50	~115	2A	200	50	50	100	100	200	300	400	(40)	(540)	500	180 x M12/12F7
MR402055R50	~126	2A	200	50	50	100	100	200	300	400	(40)	(590)	550	200 x M12/12F7
MR402060R50	~138	2A	200	50	50	100	100	200	300	400	(40)	(640)	600	220 x M12/12F7
MR402065R50	~149	2A	200	50	50	100	100	200	300	400	(40)	(690)	650	240 x M12/12F7
MR402070R50	~162	2B	200	50	50	100	100	200	300	400	(40)	(740)	700	260 x M12/12F7
MR402075R50	~172	2B	200	50	50	100	100	200	300	400	(40)	(790)	750	280 x M12/12F7

\* Gewicht ohne Grundplatte! / Weight without baseplate!

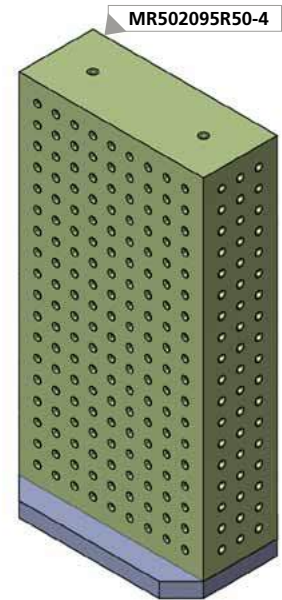
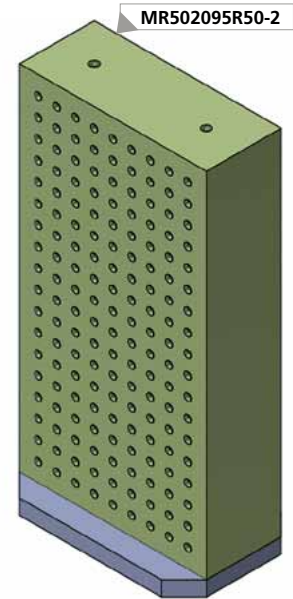
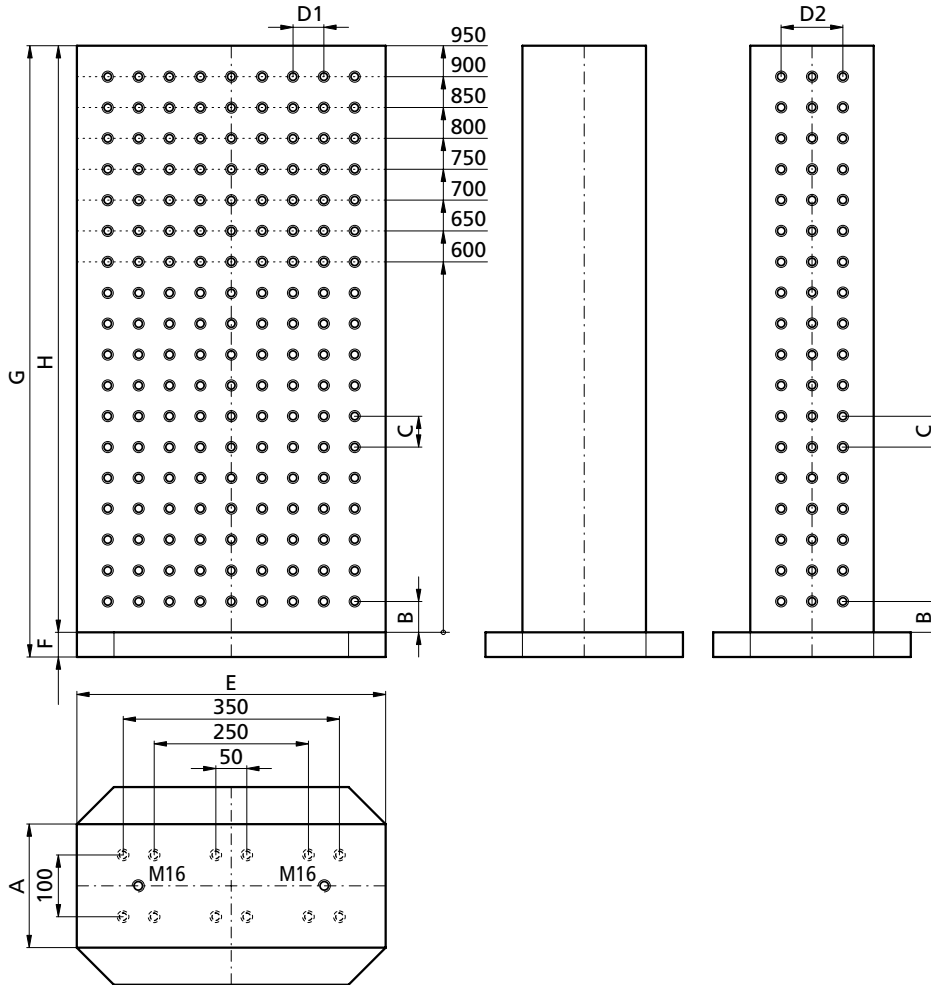
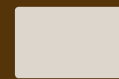

Mineralgussturm mit  
Stahldübel  
Epoxy Mineral with  
Steel Anchor

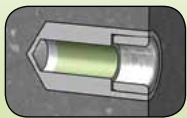

Seite / Page 250

Bestellbeispiel

Ordering example: MR502060R50-2 & \_\_\_\_\_ p. 274

Grundplatte wird passend  
zu Ihrer Maschinenpalette  
hergestellt und muss separat  
bestellt werden!  
Base plate according to your  
machine configuration please  
order extra!

	kg*	A	B	C	D1	D2	E	F	G	H	Raster / Grid
MR502060R50-2	~165	200	50	50	50		500	(40)	(640)	600	198 x M12/12F7
MR502065R50-2	~179	200	50	50	50		500	(40)	(690)	650	216 x M12/12F7
MR502070R50-2	~193	200	50	50	50		500	(40)	(740)	700	234 x M12/12F7
MR502075R50-2	~208	200	50	50	50		500	(40)	(790)	750	252 x M12/12F7
MR502080R50-2	~222	200	50	50	50		500	(40)	(840)	800	270 x M12/12F7
MR502085R50-2	~236	200	50	50	50		500	(40)	(890)	850	288 x M12/12F7
MR502090R50-2	~251	200	50	50	50		500	(40)	(940)	900	306 x M12/12F7
MR502095R50-2	~265	200	50	50	50		500	(40)	(990)	950	324 x M12/12F7
MR502060R50-4	~171	200	50	50	50	100	500	(40)	(640)	600	264 x M12/12F7
MR502065R50-4	~185	200	50	50	50	100	500	(40)	(690)	650	288 x M12/12F7
MR502070R50-4	~199	200	50	50	50	100	500	(40)	(740)	700	312 x M12/12F7
MR502075R50-4	~214	200	50	50	50	100	500	(40)	(790)	750	336 x M12/12F7
MR502080R50-4	~228	200	50	50	50	100	500	(40)	(840)	800	360 x M12/12F7
MR502085R50-4	~242	200	50	50	50	100	500	(40)	(890)	850	384 x M12/12F7
MR502090R50-4	~257	200	50	50	50	100	500	(40)	(940)	900	408 x M12/12F7
MR502095R50-4	~271	200	50	50	50	100	500	(40)	(990)	950	432 x M12/12F7



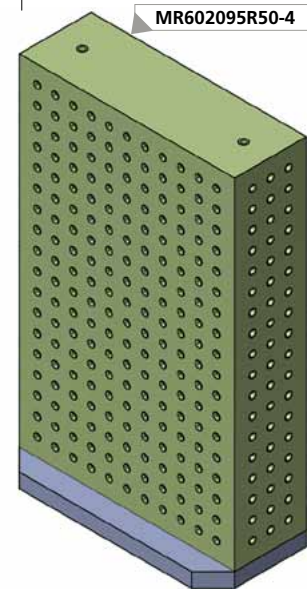
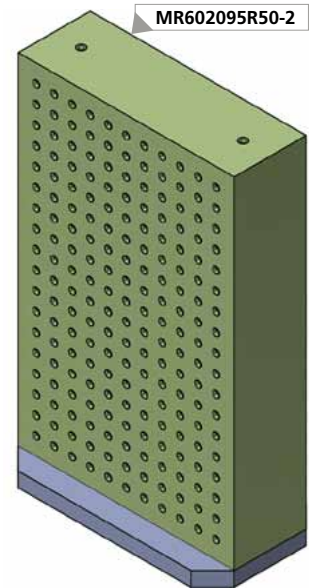
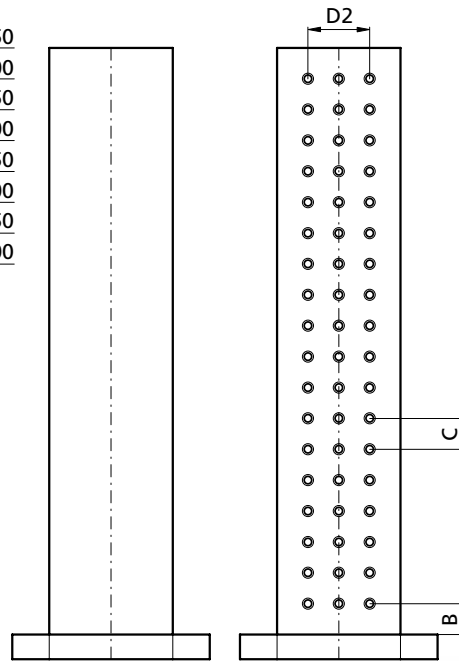
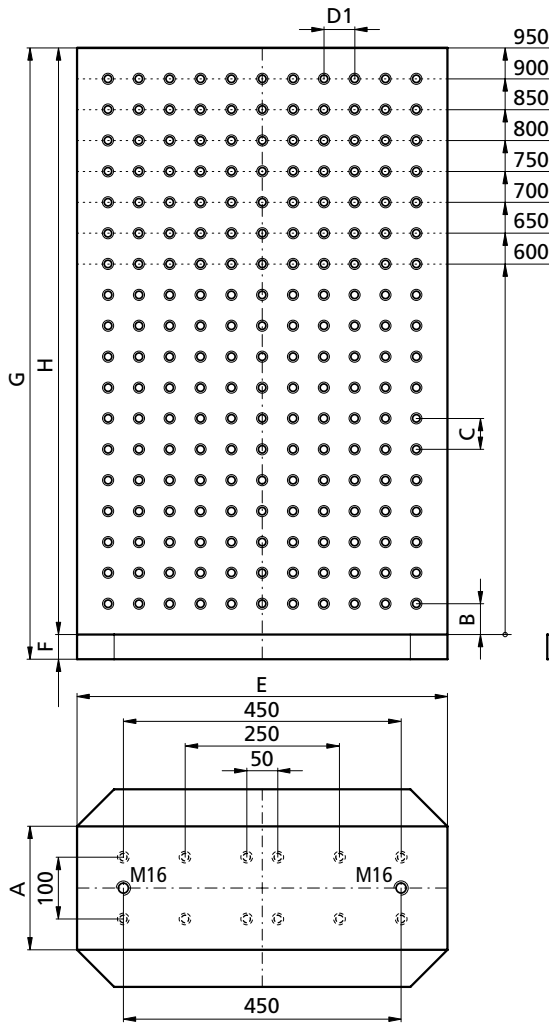
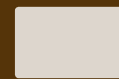

Mineralgussturm mit  
Stahldübel  
Epoxy Mineral with  
Steel Anchor

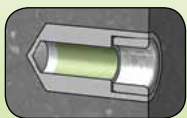

Seite / Page 250

Bestellbeispiel

Ordering example: MR602060R50-2 & \_\_\_\_\_ p. 274

Grundplatte wird passend  
zu Ihrer Maschinenpalette  
hergestellt und muss separat  
bestellt werden!  
Base plate according to your  
machine configuration please  
order extra!

	kg*	A	B	C	D1	D2	E	F	G	H	Raster / Grid
MR602060R50-2	~200	200	50	50	50		600	(40)	(640)	600	242 x M12/12F7
MR602065R50-2	~217	200	50	50	50		600	(40)	(690)	650	264 x M12/12F7
MR602070R50-2	~234	200	50	50	50		600	(40)	(740)	700	286 x M12/12F7
MR602075R50-2	~250	200	50	50	50		600	(40)	(790)	750	308 x M12/12F7
MR602080R50-2	~267	200	50	50	50		600	(40)	(840)	800	330 x M12/12F7
MR602085R50-2	~284	200	50	50	50		600	(40)	(890)	850	352 x M12/12F7
MR602090R50-2	~301	200	50	50	50		600	(40)	(940)	900	374 x M12/12F7
MR602095R50-2	~317	200	50	50	50		600	(40)	(990)	950	396 x M12/12F7
MR602060R50-4	~205	200	50	50	50	100	600	(40)	(640)	600	308 x M12/12F7
MR602065R50-4	~222	200	50	50	50	100	600	(40)	(690)	650	330 x M12/12F7
MR602070R50-4	~239	200	50	50	50	100	600	(40)	(740)	700	364 x M12/12F7
MR602075R50-4	~256	200	50	50	50	100	600	(40)	(790)	750	392 x M12/12F7
MR602080R50-4	~273	200	50	50	50	100	600	(40)	(840)	800	420 x M12/12F7
MR602085R50-4	~290	200	50	50	50	100	600	(40)	(890)	850	448 x M12/12F7
MR602090R50-4	~307	200	50	50	50	100	600	(40)	(940)	900	476 x M12/12F7
MR602095R50-4	~324	200	50	50	50	100	600	(40)	(990)	950	504 x M12/12F7

\* Gewicht ohne Grundplatte! / Weight without baseplate!

Separat bestellen / Separate order

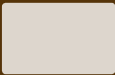

Rechteck  
Rectangle



# MR6330 ... R40

# tripoxyMINERAL

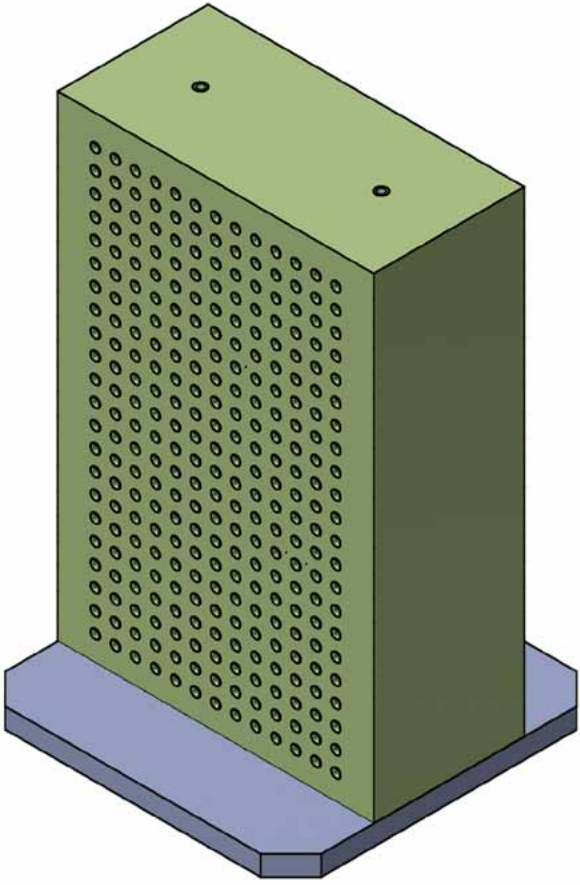
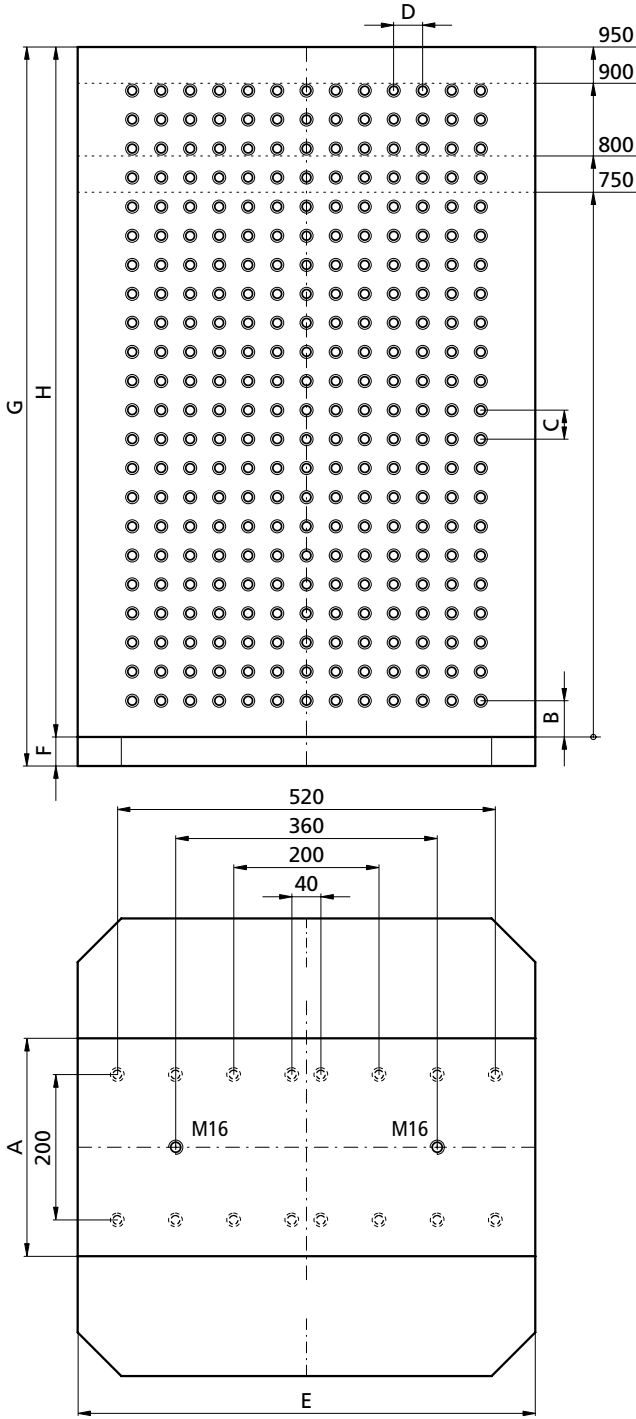

Grundplatte wird passend zu Ihrer Maschinenpalette hergestellt und muss separat bestellt werden!  
*Base plate according to your machine configuration please order extra!*

**Mineralgussturm mit Stahldübel**  
*Epoxy Mineral with Steel Anchor*

Seite / Page 250

**Bestellbeispiel**  
**Ordering example:** MR633075R40 & \_\_\_\_\_ p. 274

	kg*
MR633075R40	~314
MR633080R40	~333
MR633090R40	~374
MR633095R40	~393

	A	B	C	D	E	F	G	H	Raster / Grid
MR633075R40	300	50	40	40	630	(40)	(790)	<b>750</b>	468 x M12/12F7
MR633080R40	300	50	40	40	630	(40)	(840)	<b>800</b>	494 x M12/12F7
MR633090R40	300	50	40	40	630	(40)	(940)	<b>900</b>	546 x M12/12F7
MR633095R40	300	50	40	40	630	(40)	(990)	<b>950</b>	572 x M12/12F7

\* Gewicht ohne Grundplatte! / Weight without baseplate!

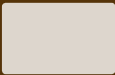

Rechteck  
Rectangle



# MR7015 ... R50

# tripoxyMINERAL

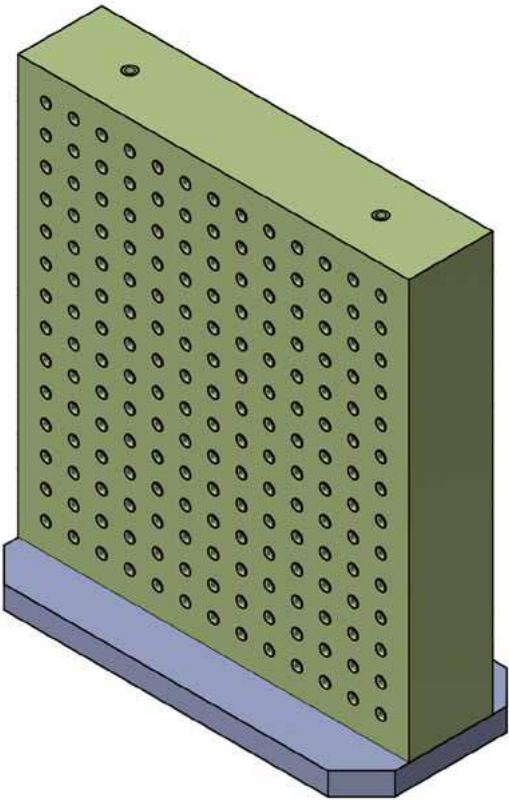
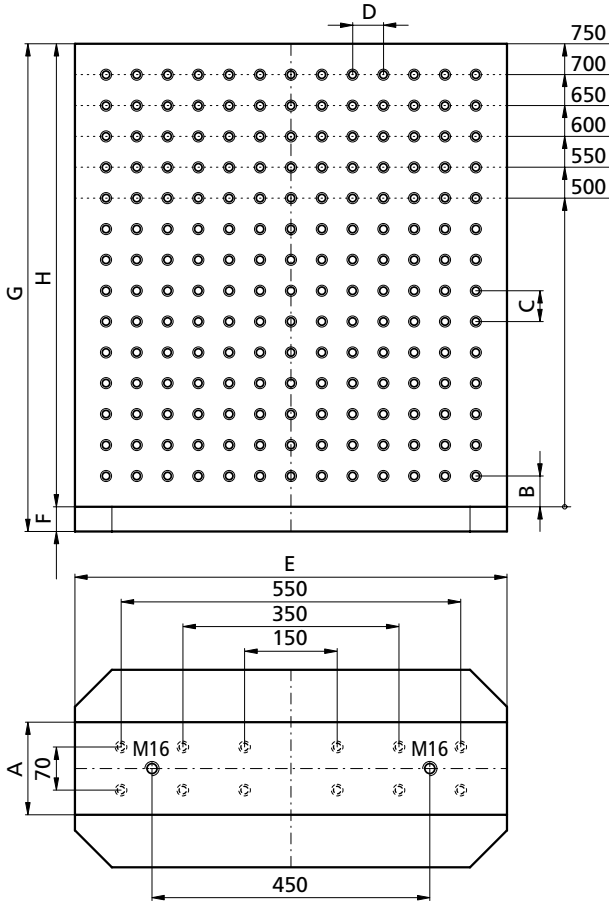

Grundplatte wird passend zu Ihrer Maschinenpalette hergestellt und muss separat bestellt werden!  
Base plate according to your machine configuration please order extra!

Mineralgussturm mit Stahldübel  
Epoxy Mineral with Steel Anchor

Seite / Page 250

Bestellbeispiel  
Ordering example: MR701550R50 & p. 274

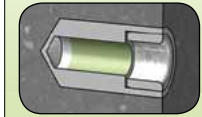

kg\*

		A	B	C	D	E	F	G	H	Raster / Grid
MR701550R50	~153	150	50	50	50	700	(40)	(540)	500	234 x M12/12F7
MR701555R50	~168	150	50	50	50	700	(40)	(590)	550	260 x M12/12F7
MR701560R50	~183	150	50	50	50	700	(40)	(640)	600	286 x M12/12F7
MR701565R50	~199	150	50	50	50	700	(40)	(690)	650	312 x M12/12F7
MR701570R50	~214	150	50	50	50	700	(40)	(740)	700	338 x M12/12F7
MR701575R50	~229	150	50	50	50	700	(40)	(790)	750	364 x M12/12F7

\* Gewicht ohne Grundplatte! / Weight without baseplate!



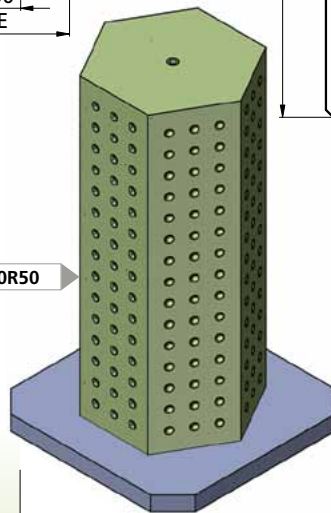
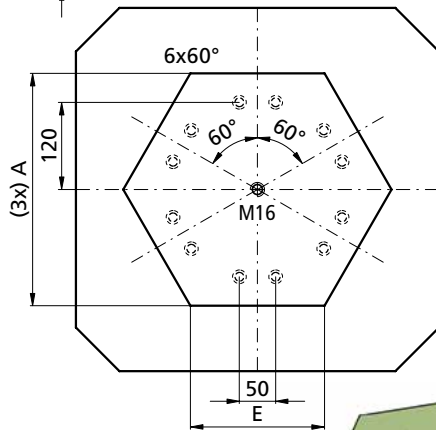
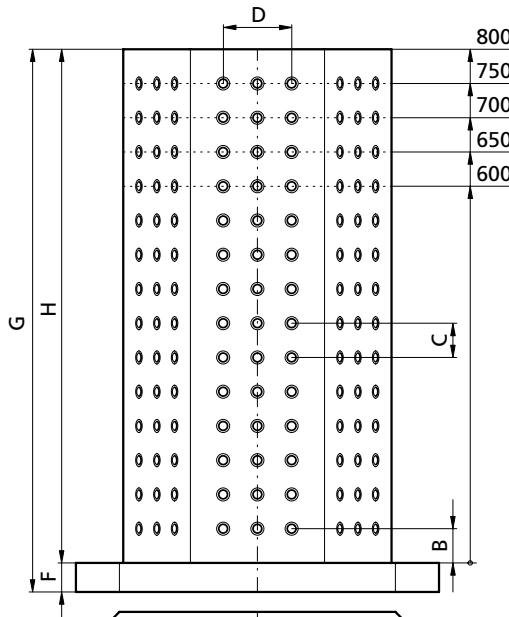

MS321980R50

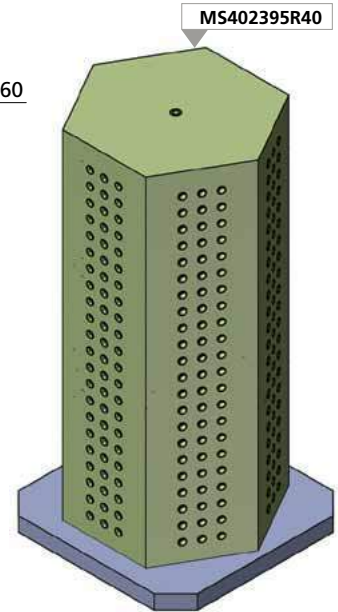
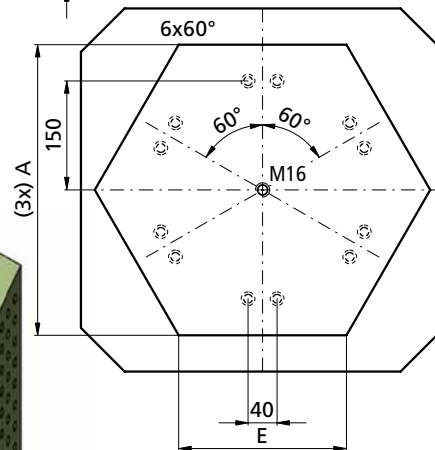
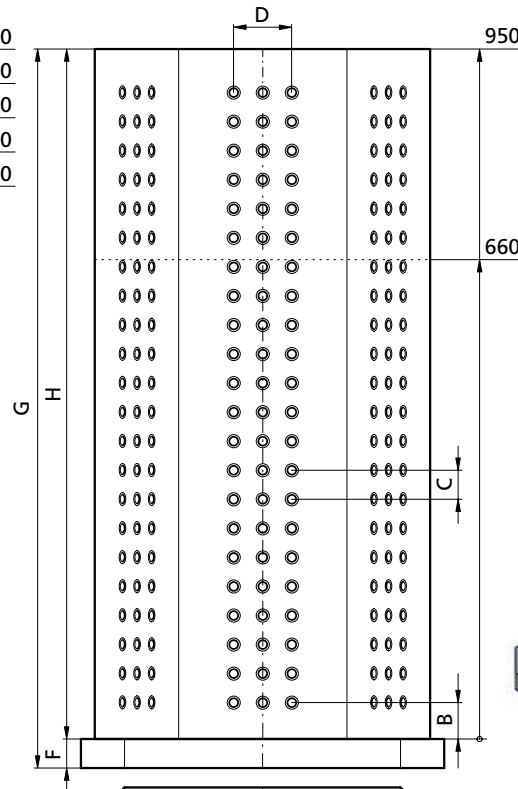

MS402395R40

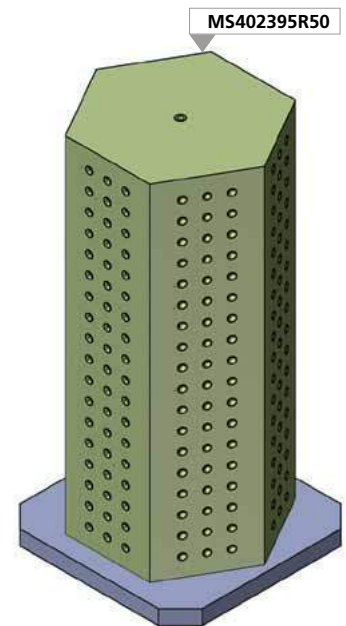

MS402395R50

Mineralgussturm mit  
Stahldübel  
Epoxy Mineral with  
Steel Anchor

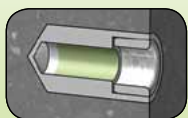

Seite / Page 250

Bestellbeispiel

Ordering example: MS321966R80 &

p. 274

Grundplatte wird passend  
zu Ihrer Maschinenpalette  
hergestellt und muss separat  
bestellt werden!

Base plate according to your  
machine configuration please  
order extra!

	kg*	A	B	C	D	E	F	G	H	Raster / Grid
MS321960R50	~120	320	50	50	100	184	(40)	(640)	<b>600</b>	198 x M12/12F7
MS321965R50	~131	320	50	50	100	184	(40)	(690)	<b>650</b>	216 x M12/12F7
MS321970R50	~142	320	50	50	100	184	(40)	(740)	<b>700</b>	234 x M12/12F7
MS321975R50	~154	320	50	50	100	184	(40)	(790)	<b>750</b>	252 x M12/12F7
MS321980R50	~165	320	50	50	100	184	(40)	(840)	<b>800</b>	270 x M12/12F7
MS402366R40	~167	400	50	40	80	231	(40)	(700)	<b>660</b>	270 x M12/12F7
MS402395R40	~311	400	50	40	80	231	(40)	(990)	<b>950</b>	396 x M12/12F7
MS402366R50	~160	400	50	50	100	231	(40)	(700)	<b>660</b>	216 x M12/12F7
MS402395R50	~260	400	50	50	100	231	(40)	(990)	<b>950</b>	324 x M12/12F7



MA2486 ... R50  
MA2486 ... R50-8

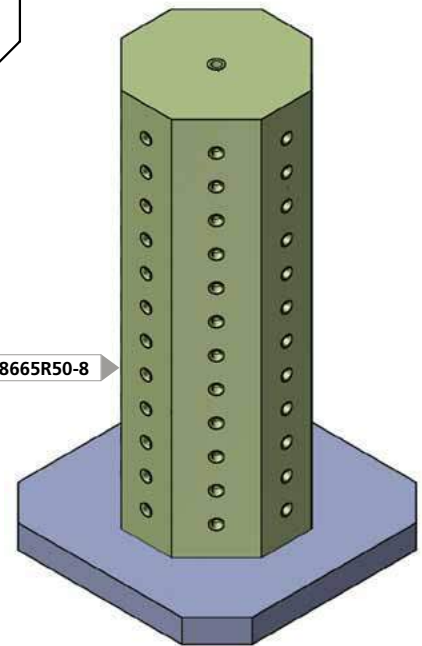
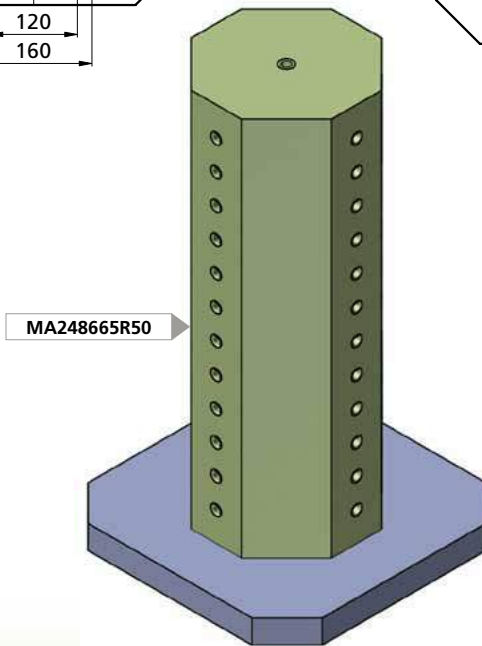
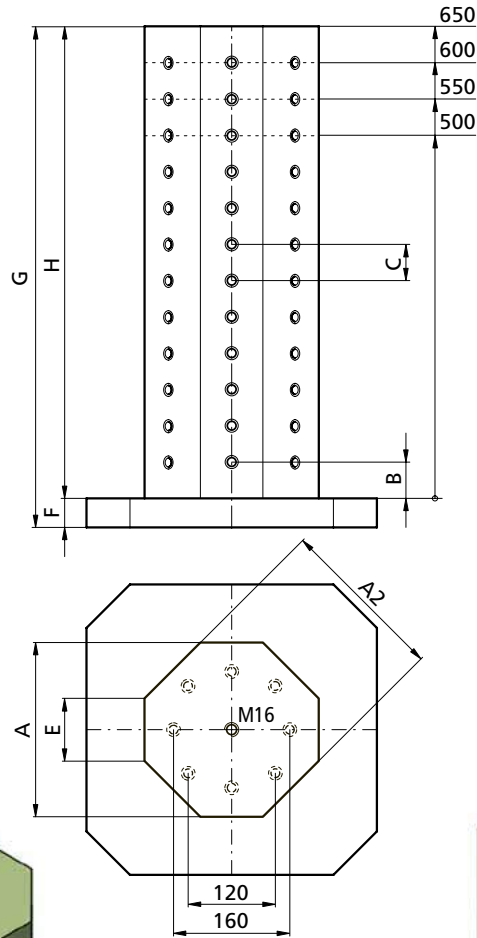
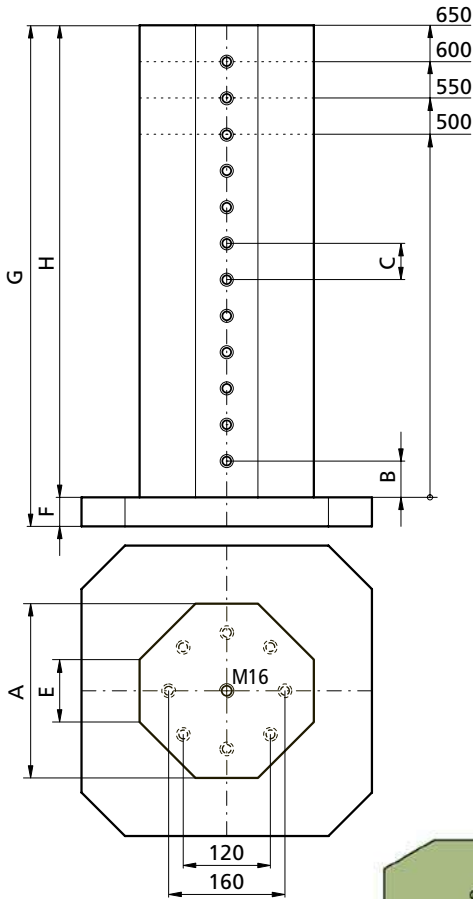

Mineralgussturm mit  
Stahldübel  
Epoxy Mineral with  
Steel Anchor

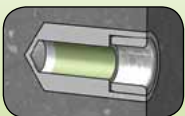

Seite / Page 250

Bestellbeispiel  
Ordering example: MR24865R50 &

p. 274

Grundplatte wird passend  
zu Ihrer Maschinenpalette  
hergestellt und muss separat  
bestellt werden!  
Base plate according to your  
machine configuration please  
order extra!

	kg*			A	A2	B	C		E	F	G	H	Raster / Grid
MA248650R50	~56			240		50	50		86	(40)	(540)	500	36 x M12/12F7
MA248655R50	~61			240		50	50		86	(40)	(590)	550	40 x M12/12F7
MA248660R50	~70			240		50	50		86	(40)	(640)	600	44 x M12/12F7
MA248665R50	~72			240		50	50		86	(40)	(690)	650	48 x M12/12F7
MA248650R50-8	~61			240	230	50	50		86	(40)	(540)	500	72 x M12/12F7
MA248655R50-8	~67			240	230	50	50		86	(40)	(590)	550	80 x M12/12F7
MA248660R50-8	~71			240	230	50	50		86	(40)	(640)	600	88 x M12/12F7
MA248665R50-8	~79			240	230	50	50		86	(40)	(690)	650	96 x M12/12F7

\* Gewicht ohne Grundplatte! / Weight without baseplate!

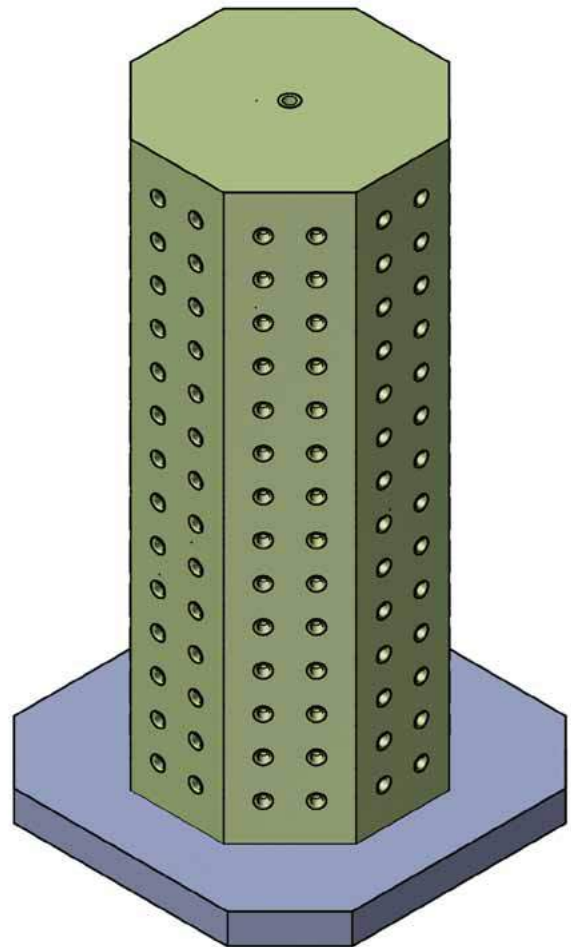
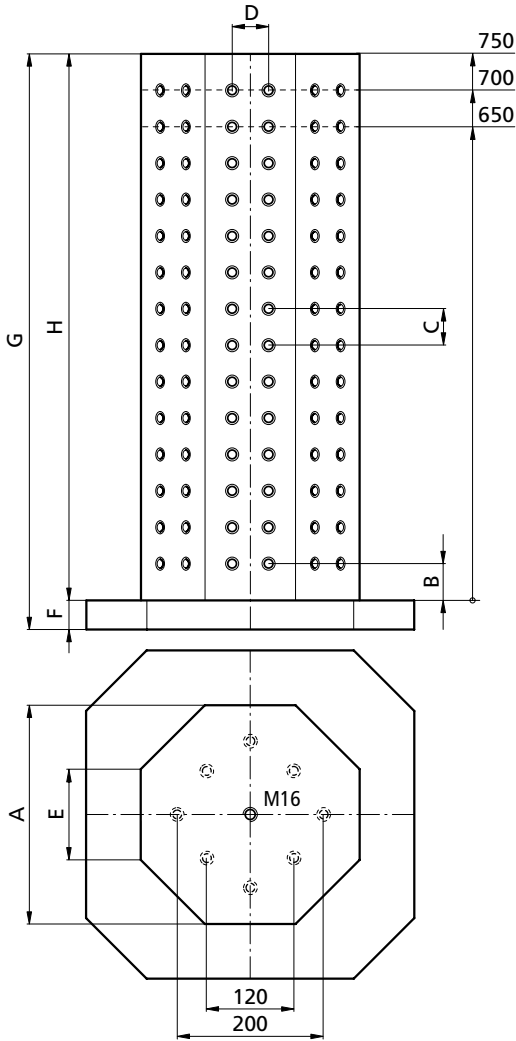

Grundplatte wird passend zu Ihrer Maschinenpalette hergestellt und muss separat bestellt werden!

*Base plate according to your machine configuration please order extra!*

Mineralgussturm mit  
Stahldübel  
Epoxy Mineral with  
Steel Anchor

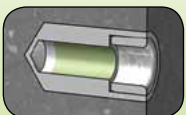

andere Höhen auf Anfrage  
other heights on request

Seite / Page 250

Bestellbeispiel

Ordering example: MA301265R50-8-2 & \_\_\_\_\_ p. 274

	kg*	A	B	C	D	E	F	G	H	Raster / Grid
MA301265R50-8-2	~118	300	50	50	50	125	(40)	(690)	<b>650</b>	192 x M12/12F7
MA301270R50-8-2	~130	300	50	50	50	125	(40)	(740)	<b>700</b>	208 x M12/12F7
MA301275R50-8-2	~156	300	50	50	50	125	(40)	(790)	<b>750</b>	224 x M12/12F7

\* Gewicht ohne Grundplatte! / Weight without baseplate!



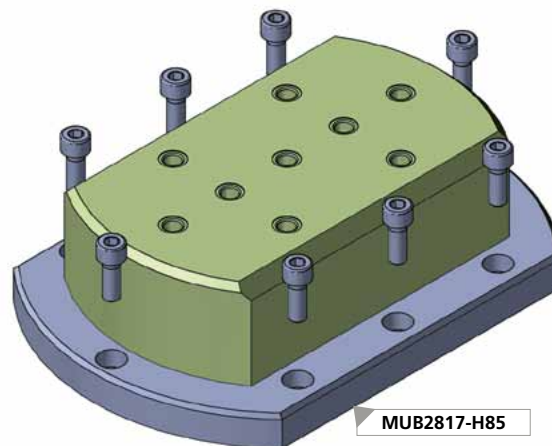
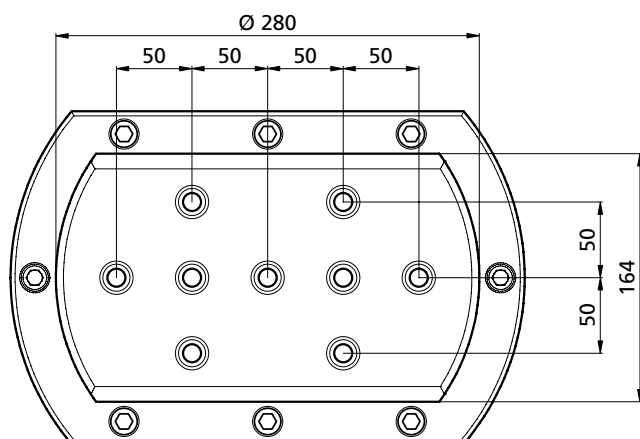
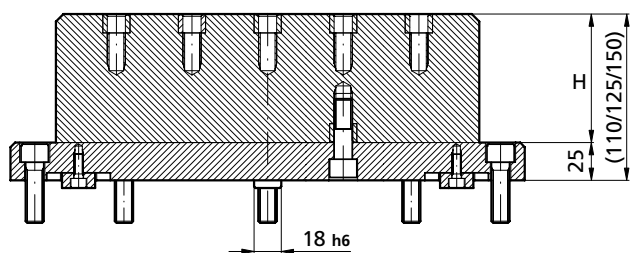

MUB2817-H85



PA5X94-49R



Bestellnummer Order number	Abmessung Dimension	
	H	kg
MUB2817-H85	85	~10
MUB2817-H100	100	~12
MUB2817-H125	125	~15

Bestellbeispiel / Ordering example: 1x MUB 2817 H85 & 1x TH160645 8 x M12X35ISO4762

Separat bestellen / Separate order



**SMK24-24-42 OPP200**

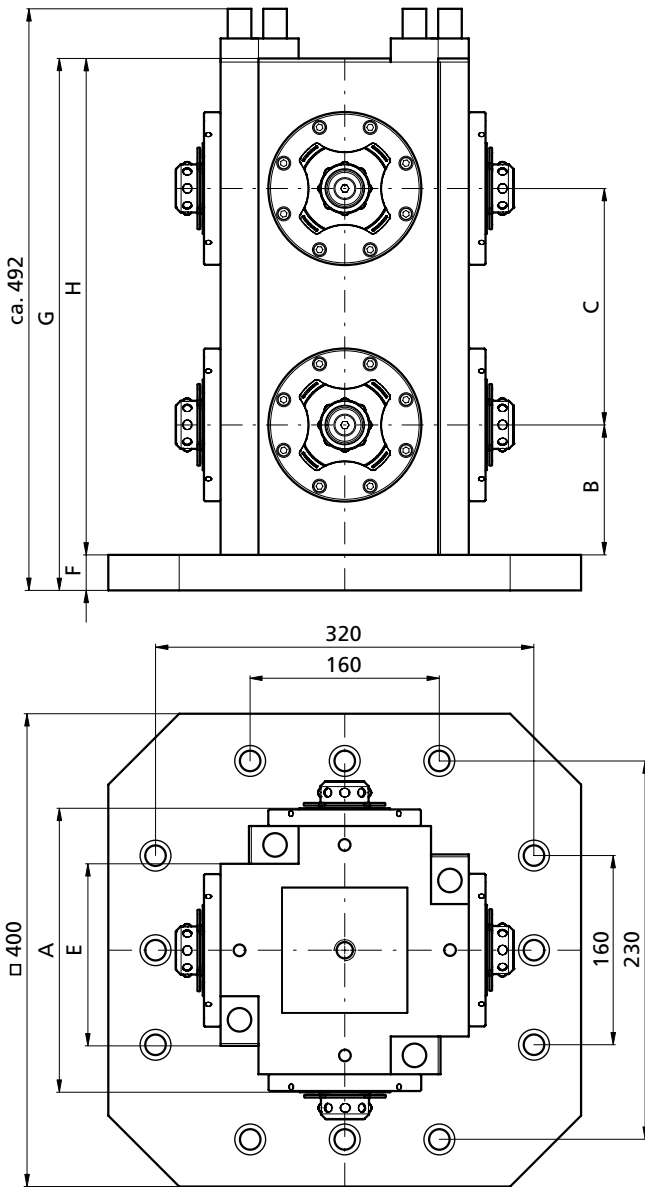

**SMK30-17-42 OPP200**

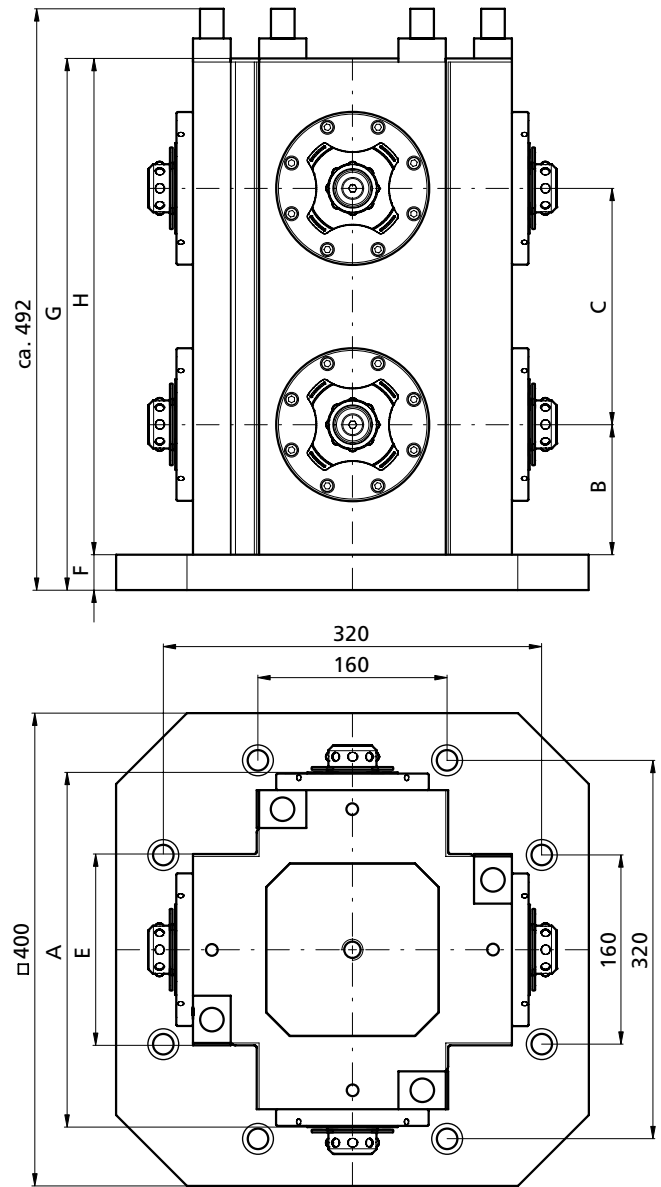

**Stahl-Mineralguss**

**Steel-epoxy mineral tombstones**

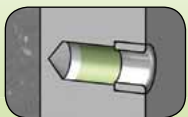

andere Höhen auf Anfrage  
 other heights on request

Seite / Page 250

**Bestellbeispiel**  
 Ordering example: **SMK242442OPP-200**

	kg	A	B	C	E	F	G	H	Raster / Grid
SMK24-24-42OPP200	~120	240	110	200	166	(30)	(450)	<b>420</b>	OPP-200
SMK30-17-42OPP200	~142	300	110	200	166	(30)	(450)	<b>420</b>	OPP-200

# Stahl-Mineralgusstürme Steel-epoxy mineral tombstones



tripoxyMINERAL

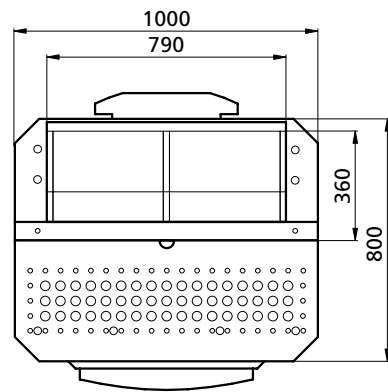
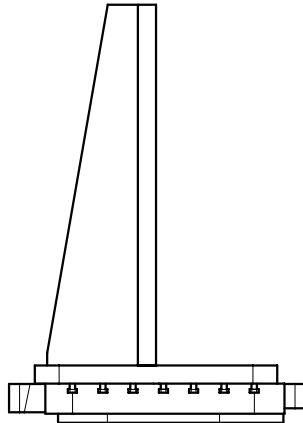
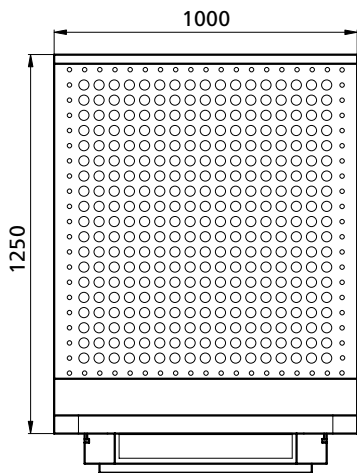

Gesamtgewicht  
Total weight ~1300 kg



Epoxy



Stahl / Steel





Grundplatten für Mineralgusstürme Base plate for epoxy mineral tombstone	A	B	C	kg
GPL30040	300	300	40	~27
GPL40040	400	400	40	~47
GPL50040	500	500	40	~74
GPL45040	450	450	40	~61
GPL50040040	500	400	40	~58
GPL63040	630	630	40	~120
GPL80040	800	800	40	~195

Rasterplatten für 5AX-Master Grid plate for 5AX-Master	A	B	C	Raster / Grid	kg
RPQ50504-R50	500	500	40	M12/12F7	~74
RPD504-R50	∅ 500		40	M12/12F7	~64

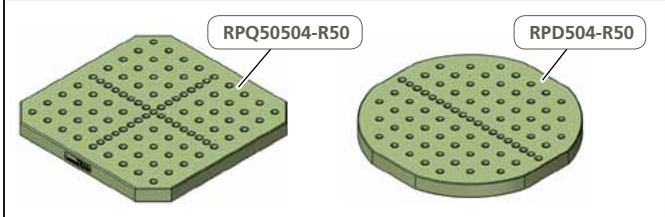

Andere Grössen auf Anfrage  
Other dimensions available on request

Im Lieferumfang: Schrauben zur Befestigung des Turms, ohne Positionierzapfen und Schrauben maschinenseitig.  
The package: Screws for fixing the tombstone, without screws and counter piece to the machine side.

Bohrungen der Grundplatte / Drill holes in the baseplate:  
Kundenspezifisch an die Maschine angepasst  
Made up to customer's specifications

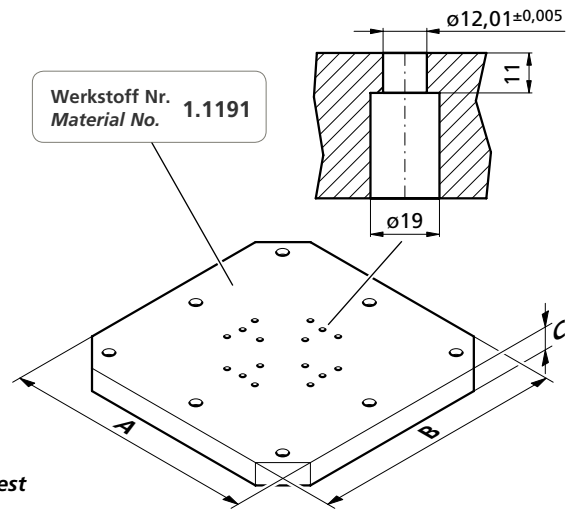

GPL40040-UV  
kg ~40,34

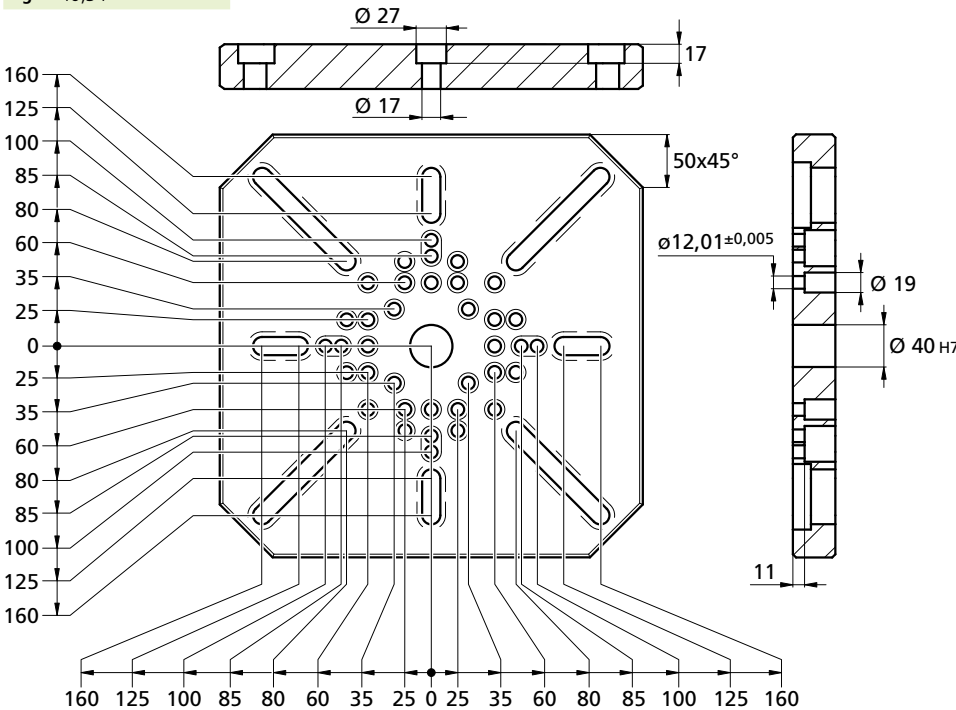

27 verschiedene Mineralgusstürme  
passend zu dieser Grundplatte.  
27 different Epoxy mineral tombstone  
are suitable for this base plate.

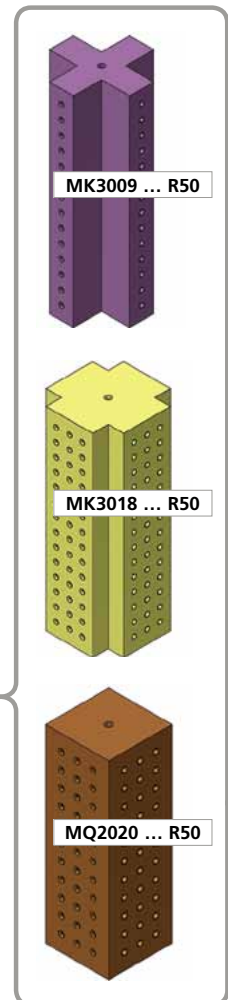



**Abdeckbleche zum Schutz der Oberfläche der Mineralgusstürme**  
**Cover plates for surface protection of epoxy mineral tombstones**

**MABD501550**

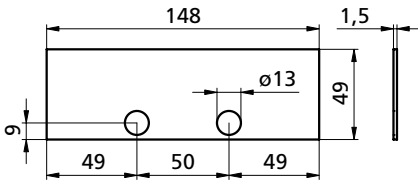

**MABD502050**

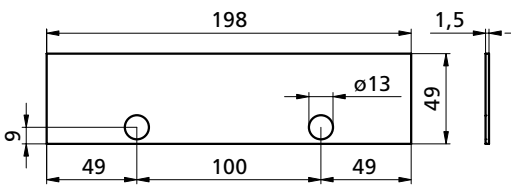

**MABD502550**

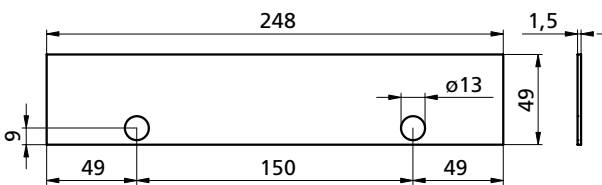

**MABD503050**

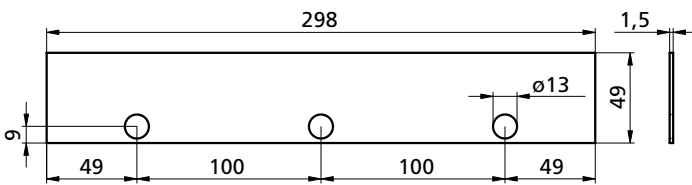

**M12X25DIN7984**

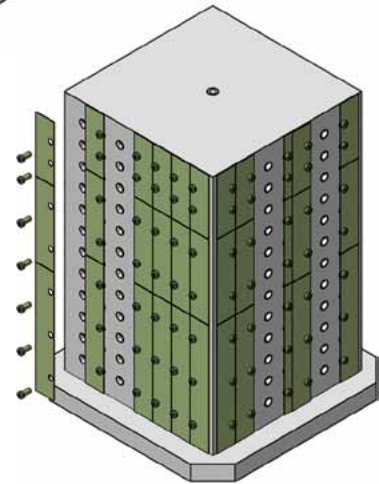
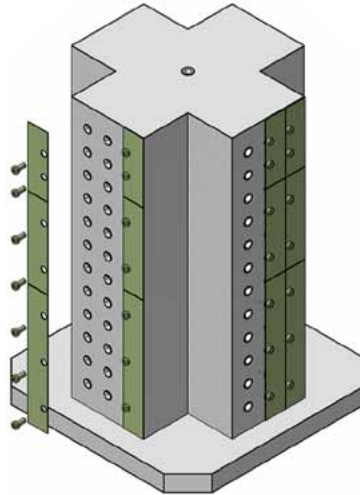
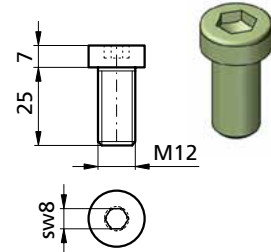

**Stahl-Mineralguss**  
**Steel-epoxy mineral tombstones**

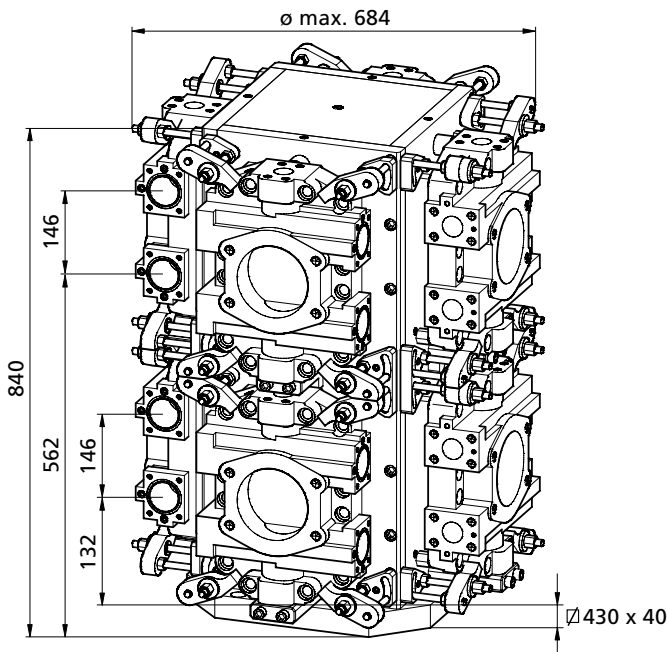

Gesamtgewicht  
 Total weight  
**~600kg**

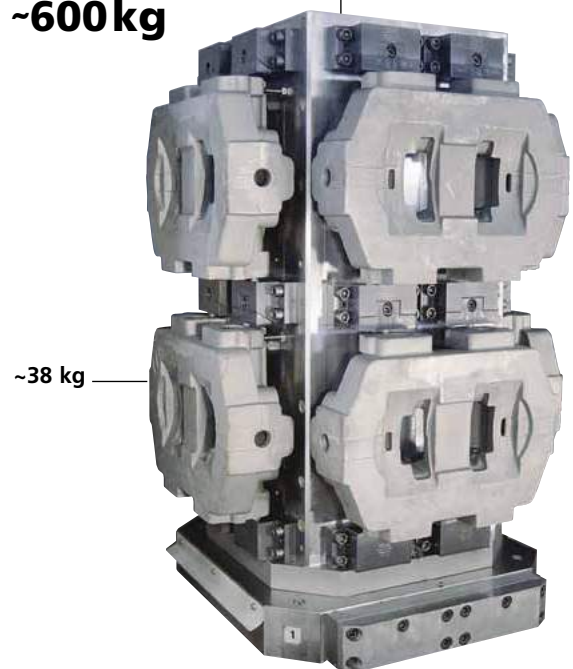

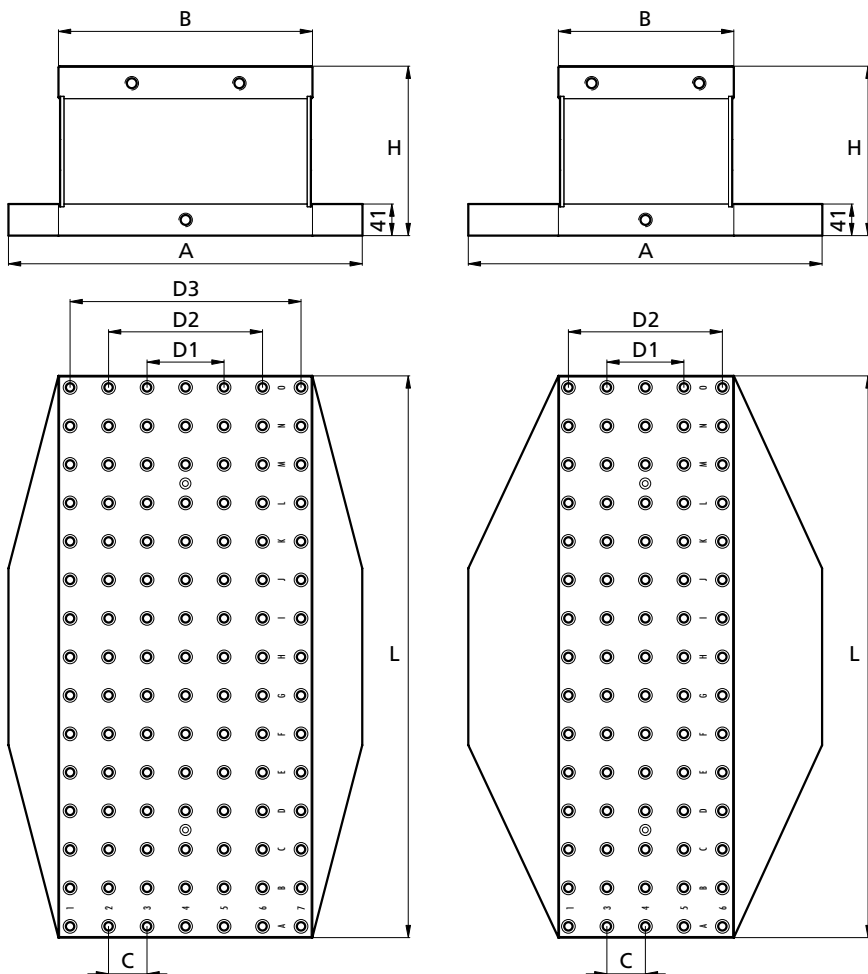

**Entwickelt für die Luftfahrt.  
Gewappnet für höchste Anforderungen.**

Sehr hohe Vibrationsdämpfung dank Kern aus Mineralguss. Hohe Festigkeit dank Ummantelung aus Stahl. Begünstigt die Gewichtsreduktion wodurch die Maschine geschont wird.

Mit intergrierten Vakuum Kanälen erhältlich.

**Developed for aviation.  
Prepared for the highest requirements**

Very high vibration damping thanks to mineral cast core. High strength thanks to the coat made of steel. Supports weight reduction which protects the machine.

Raisers can be made with integrated vacuum channels.

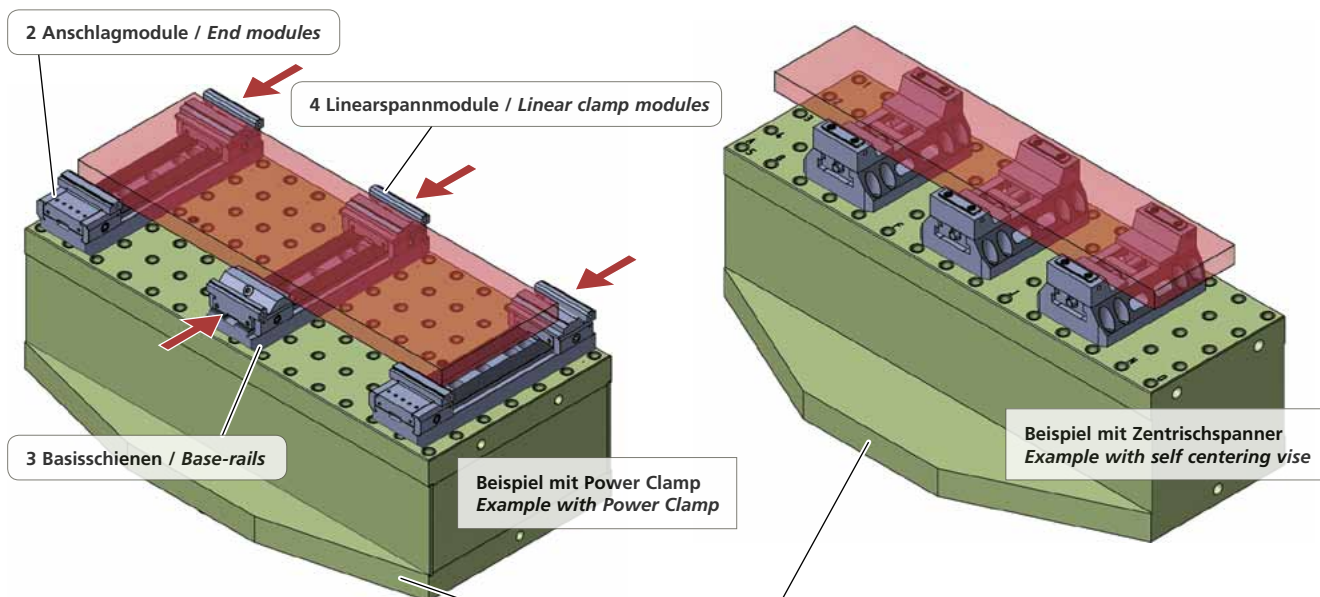

Grundplatte wird passend zu Ihrer Maschinenpalette hergestellt!  
Base plate according to your machine configuration!

Stahl-Mineralguss

Steel-epoxy mineral tombstones

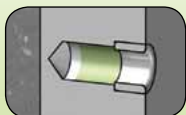

Bestellbeispiel  
Ordering example: **SMUB2373H220**

	kg	A	B	C	D1	D2	D3	H	L	Raster / Grid
SMUB2373H220	~168,0	460	230	50	100	200		220	730	75 x M12/12F7
SMUB3373H220	~214,4	460	330	50	100	200	300	220	730	105 x M12/12F7



# Stahl-Epoxy Erhöhung mit integriertem Vakuum Anschluss

## Steel-epoxy riser block with integrated vacuum



tripoxyMINERAL

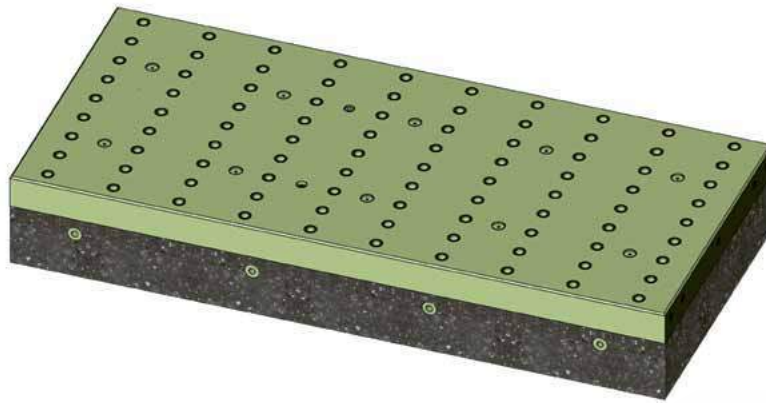
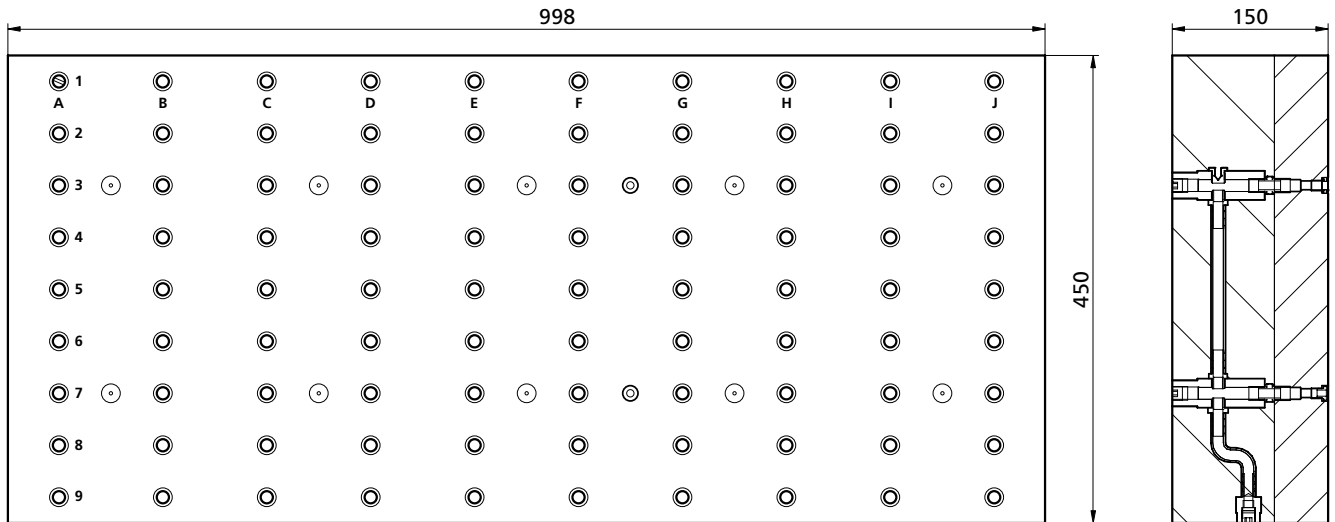

**Balken und Würfel aus Stahl-Mineralguss**  
*Trunion and cubes made from steel epoxy*

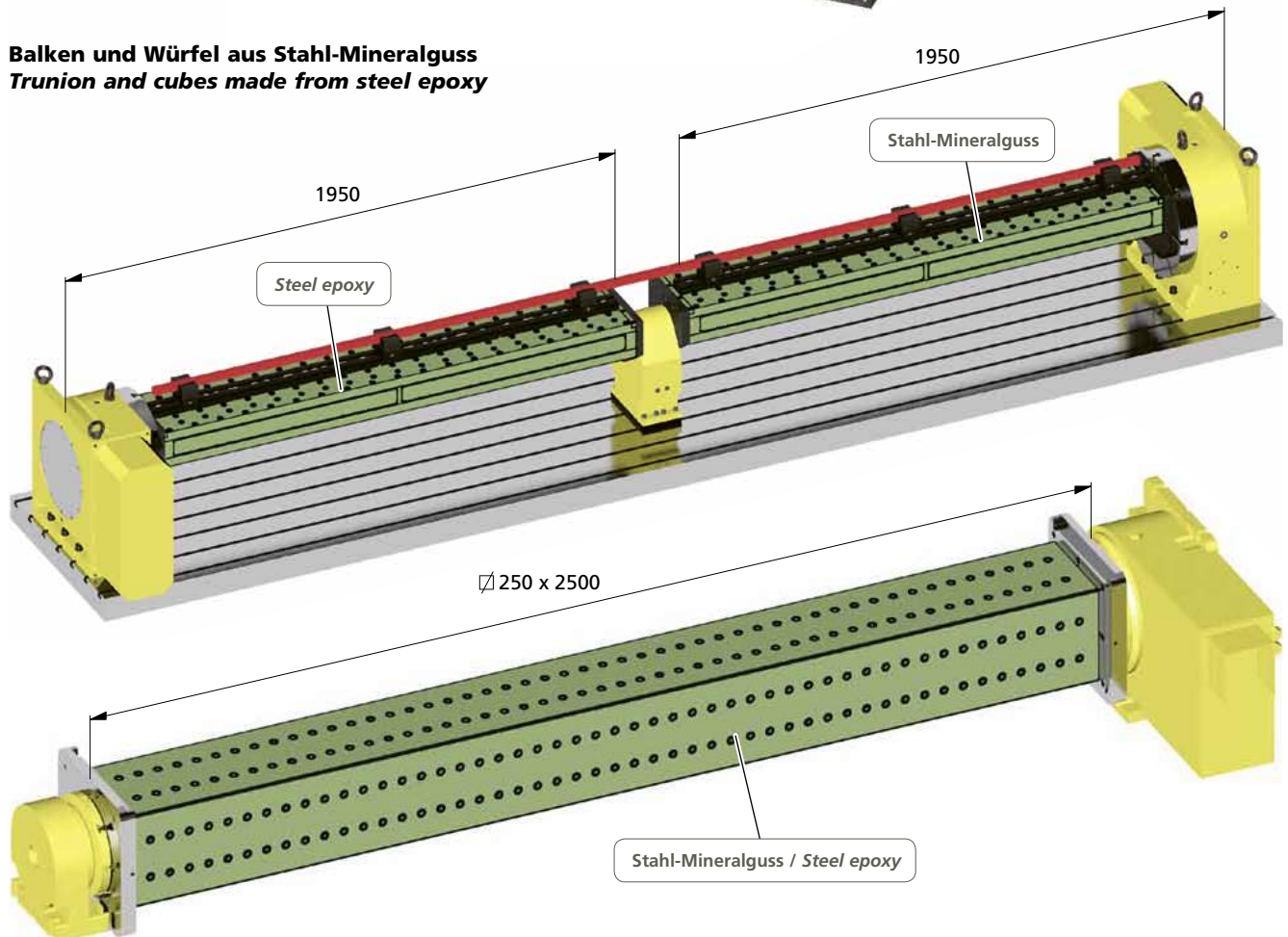

Mineralgusstürme seit  
*Epoxy tombstones since*

1998

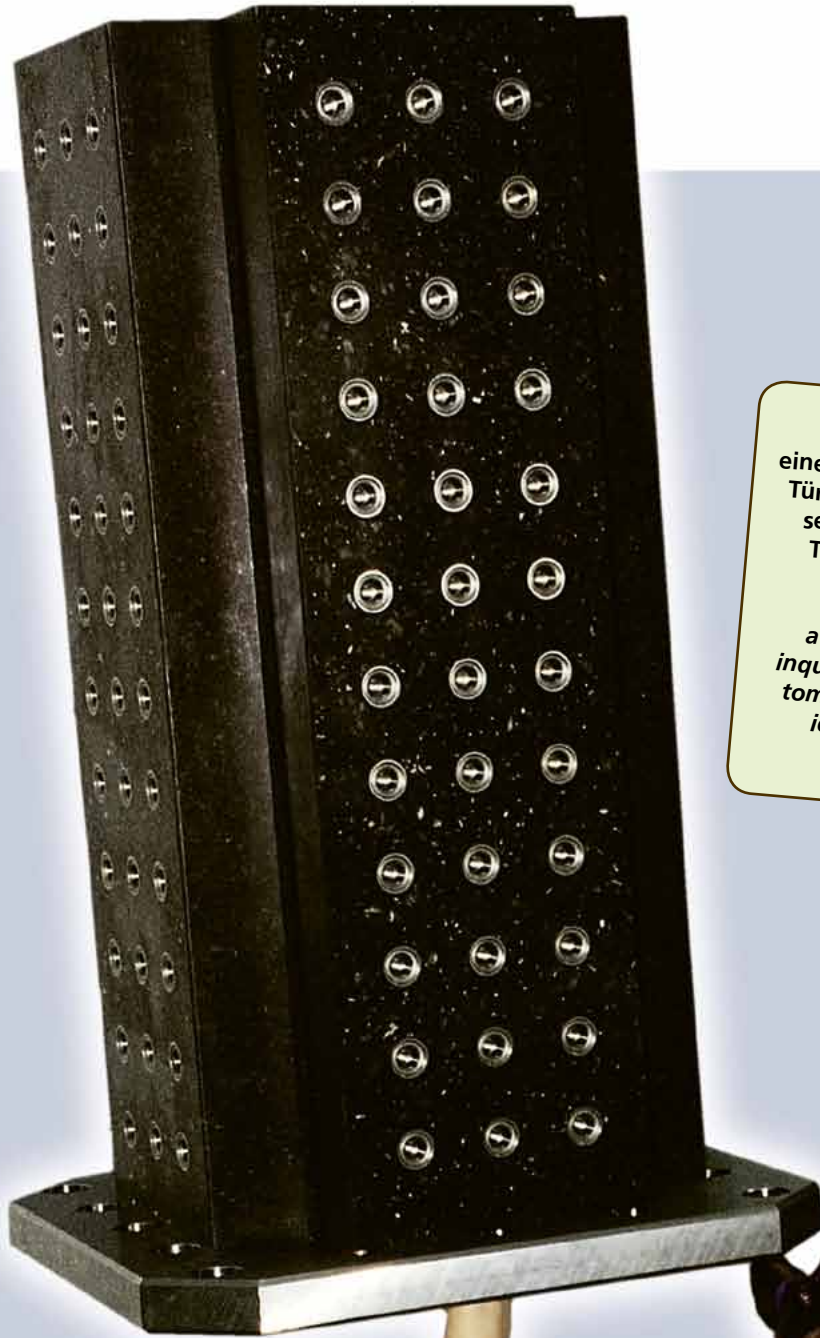

Beat Baumgartner erhält von einem Kunden eine Anfrage für leichte Türme, die aber nicht aus Aluminium sein dürfen. Er hat die Idee, einen Turm aus Mineralguss zu bauen.

*Beat Baumgartner receives a request from a customer who inquires about light, non-aluminium tombstones. He comes up with the idea to build a mineral epoxy tombstone.*

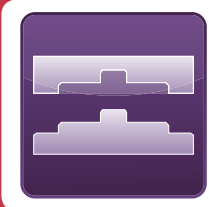

**oppSystem**

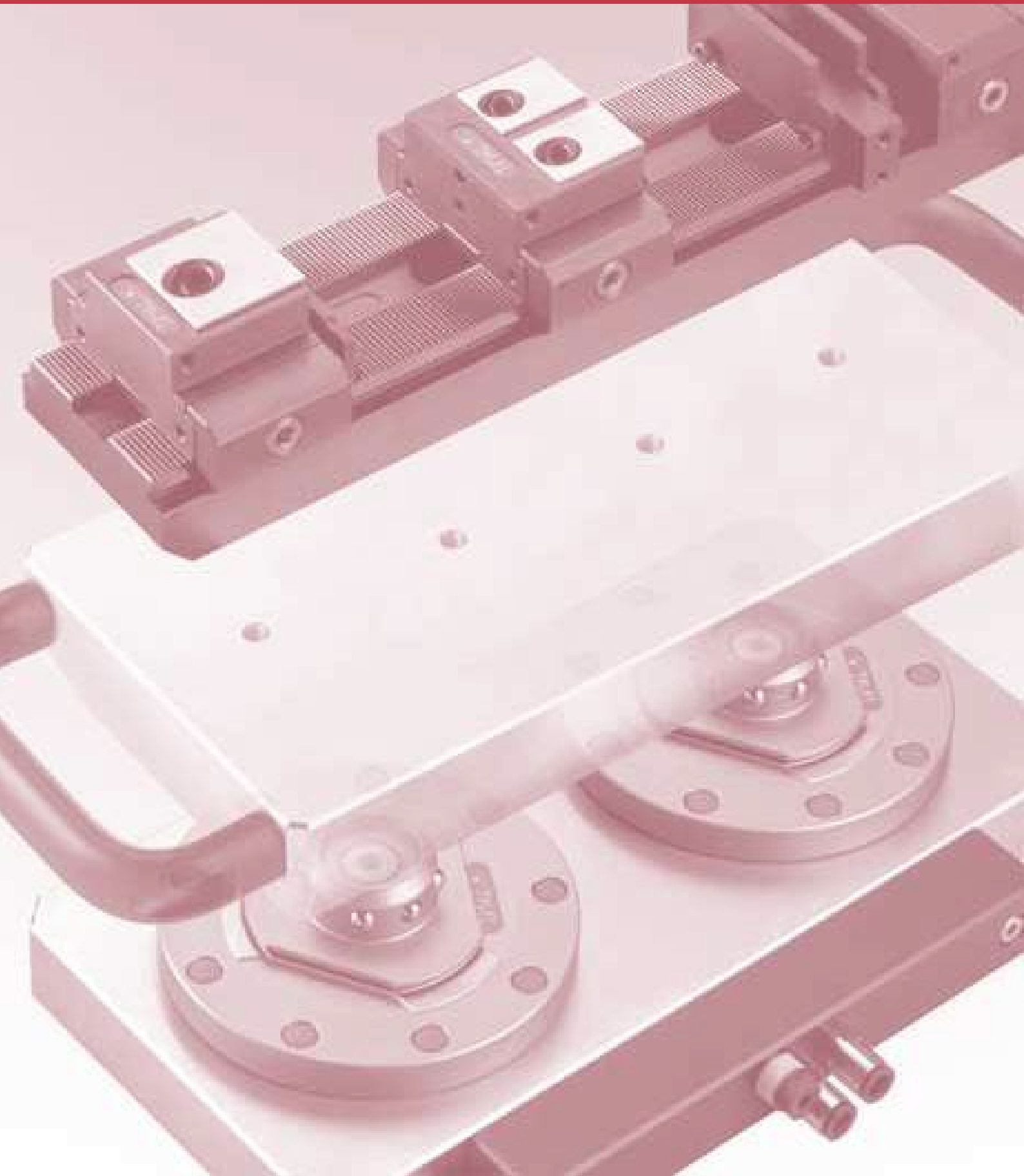





Einleitung | *Introduction* ..... 281 - 283

Anwendungsbeispiele | *Examples of application* ..... 284 - 285

Mechanisches Nullpunktsystem mit diversen Spannlösungen  
*Mechanical zero point system with different workholding solutions* ..... 286

0-Punkt Schnellwechselsystem | *Mechanical zero point system* ..... 287



0-Punkt Erhöhung | *Zero point riser*  
 Universal Flansch | *Universal flange* ..... 288

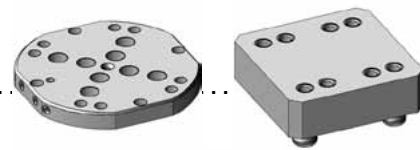

Ausrichtplatte | *Alignment plate* ..... 289



Dreibackenfutter | *Three-jaw chuck* ..... 290

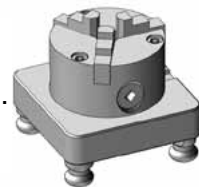

Klemmbüchse | *Clamping-case* ..... 291



Zentriereinheit | *Chuck unit* ..... 292



Palettenträger | *Receiver chuck with chucks* ..... 293

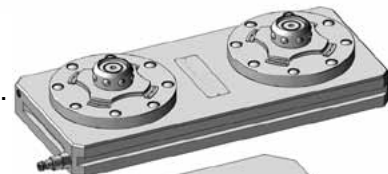

MTS Palettier-System | *MTS palleting system* ..... 297 - 300

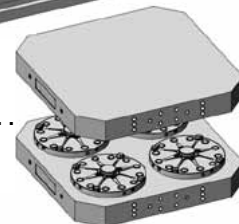

Zubehör | *Accessoires* ..... 301



## Nullpunkt-Palettiersystem

## Zero-point palleting system

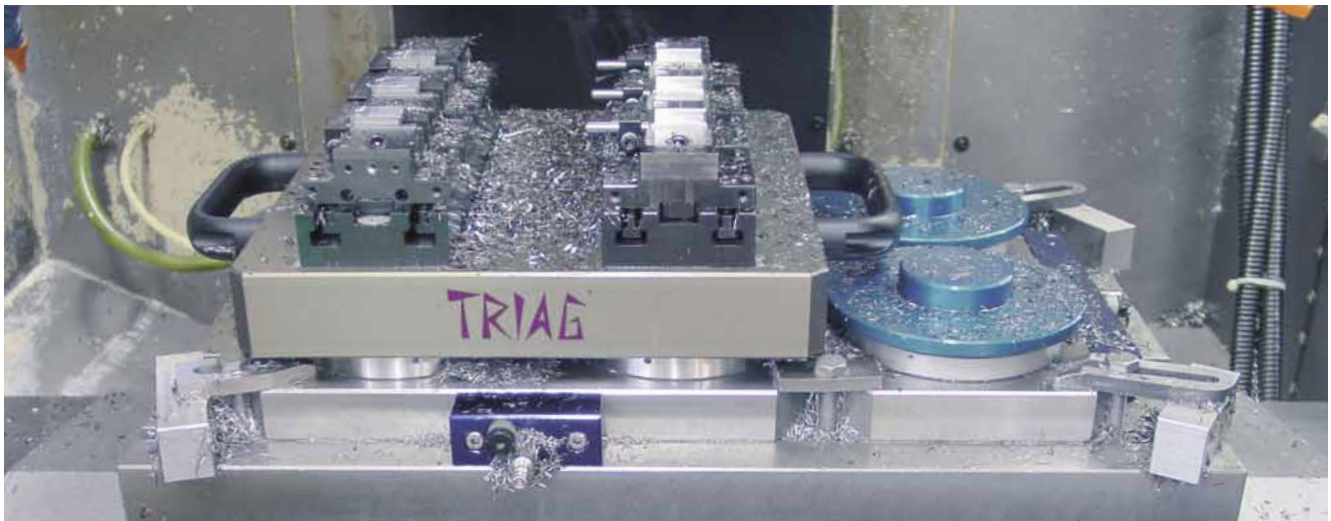

In den letzten Jahren wurden die Werkzeugmaschinen viel leistungsfähiger. Damit wurden die Bearbeitungszeiten wesentlich kürzer. Aufgrund der vom Auftraggeber verlangten Lieferzeiten „just in time“ sind aber die Losgrößen geringer geworden, was zu vermehrten Einrichtzeiten führt.

*The productivity of modern machining centers has been drastically increased over the past years. Hence the time per workpiece is falling. On the contrary the batch sizes are getting smaller due to the increasing trend to „just in time“ production.*

Auch die technisch hochentwickelten Maschinen sind jedoch immer noch mit einem T-Nuten Tisch ausgerüstet. Die Befestigung und das Ausrichten des zu bearbeitenden Werkstückes auf dem T-Nutentisch kann nur während der (teuren) Maschinenstillstandszeit erledigt werden. Diese Unproduktivität kumuliert sich, wenn die Werkstückbearbeitung mehrere Maschinenprozesse und somit mehrmaliges Befestigen und Ausrichten erfordert.

*This means that the machine must be set up more frequently. Is the machine not equipped with a pallet changer, the set up and the changing of workpieces may only be accomplished during the stand still of the machine. This idling of the machine results in the loss of costly productive machine time. As it is, the aim of any machining facility to keep the spindle turning, the unproductive time must be minimized. As any machinist knows, the set up and alignment of workpieces on a T-slot table is very awkward and time consuming.*

Die Lösung, die wir Ihnen für dieses Problem bieten, ist unser neuartiges, modulares Palettiersystem, das oppSystem.

*The TRIAG opp (Zero-Point-Palleting) System represents an ideal interface between machining table and workholding device.*

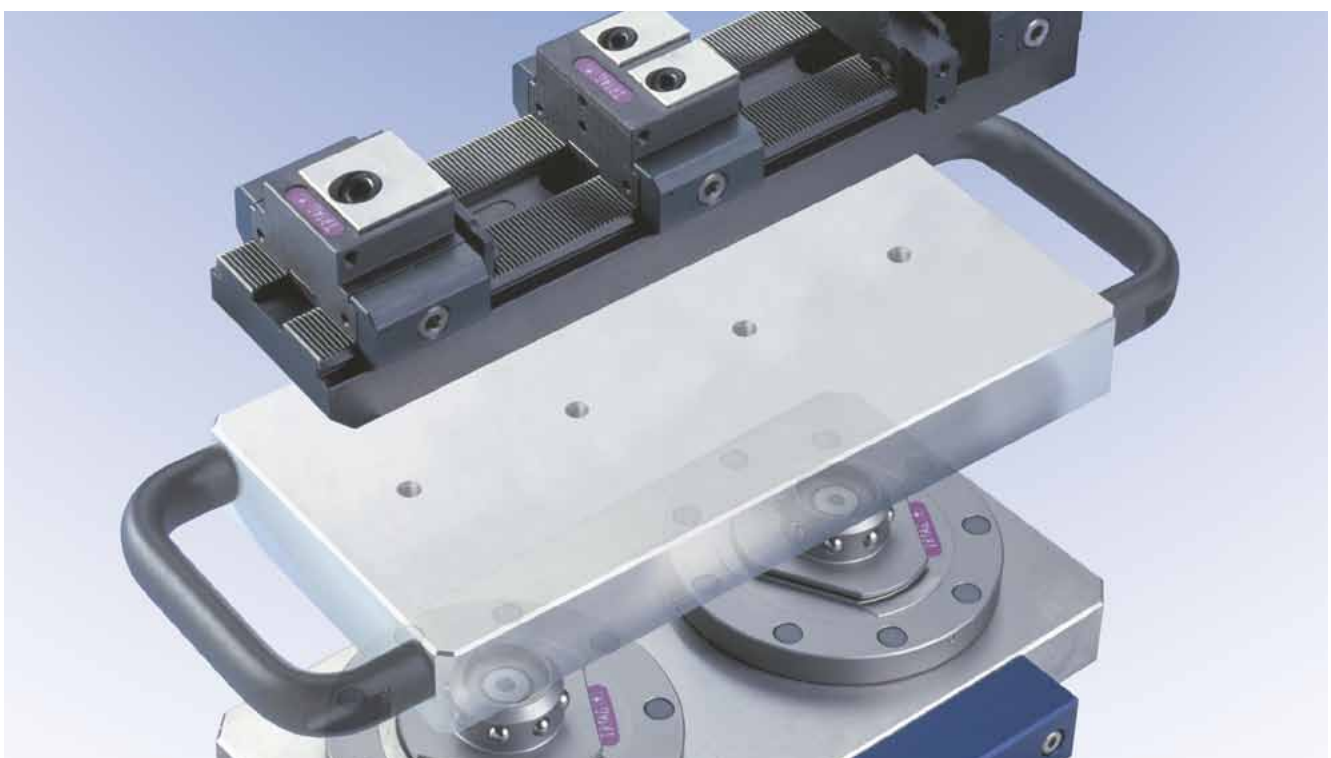



Das System besteht aus dem auf dem Maschinentisch der Werkzeugmaschine montierten Palettenträger und mindestens zwei Paletten oder mit Zentrier- und Klemmbüchsen ausgerüsteten Werkstückträgern. Die sehr präzise gefertigte Schnittstelle zwischen dem Palettenträger und der Palette ermöglicht ein sekundenschnelles Ein- und Auswechseln der Paletten, auf welcher ausserhalb der Werkzeugmaschine das zu bearbeitende Werkstück montiert und positioniert wird. Es wird eine sehr hohe Ausnutzung der theoretisch zur Verfügung stehenden Maschinenlaufzeit erreicht. Dies erhöht die Produktivität der Maschine und damit die Wirtschaftlichkeit des ganzen Betriebes.

Im Gegensatz zu vielen anderen Palettiensystemen auf dem Markt ist die Dimension des oppSystems in Form von Stichmassen genormt und richtet sich damit nach den individuellen Werkstückdimensionen. Die patentierte Konstruktion erlaubt überdies auch die unbemannte Be- und Entladung mit Hilfe eines Beschickungsgerätes.

Mit dem oppSystem sind 750'000 Spannungen ohne Referenzverlust möglich, bei einer Repetiergenauigkeit von  $\pm 0,002$  mm. Das Lösen erfolgt pneumatisch mit ca. 6 bar, womit keine Mehrkosten für Hydraulikaggregate entstehen. Eine allfällig entstehende Wärmeausdehnung wird über die federnde Zentrierung kompensiert. Alle wichtigen Bauteile sind wartungsarm, leicht zu überprüfen und im Bedarfsfall einfach auszutauschen.

*On the machine table the receiver chuck is installed. This chuck may consist of one, two, four, six or more receiver units. Onto these air operated receiver chucks a pallet, a fixture or a vice is mounted within a matter of seconds. On the bottom surface of the workholding devices centering rings are inserted. These centering rings are ground to a very high accuracy permitting the locking down of the workholding device with a repeatability of  $\pm 0.002$  mm on all three axes. The chucks are locked by spring force and unlocked by compressed air of 6 bar. This means that no hose connection is necessary during machining. Hydraulic pumps or hydraulic amplifiers are superfluous.*

*The patented oppSystem allows for 750'000 locking and unlocking cycles without loss of positioning accuracy. If necessary, the changing of the pallet may be accomplished by a robot or a handling system. Thermal expansion is compensated for by the spring loaded centering units.*

*Due to the unique oppSystem it is possible to bring the loading and unloading of the actual workpiece out of the machine which guarantees a maximum of productive machine time. Maintenance is simple as all components are easily accessible and replaceable. There are standard receiver chucks and pallets available with two or four receiver units. For other solutions or dedicated fixture you should contact TRIAG or your nearest dealer.*

SMK30-17-42 OPP200 ~ 142 kg

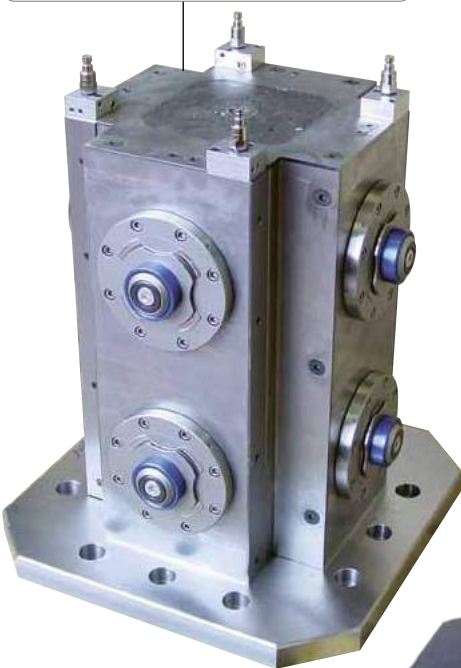

SMK24-24-42 OPP200 ~ 120 kg

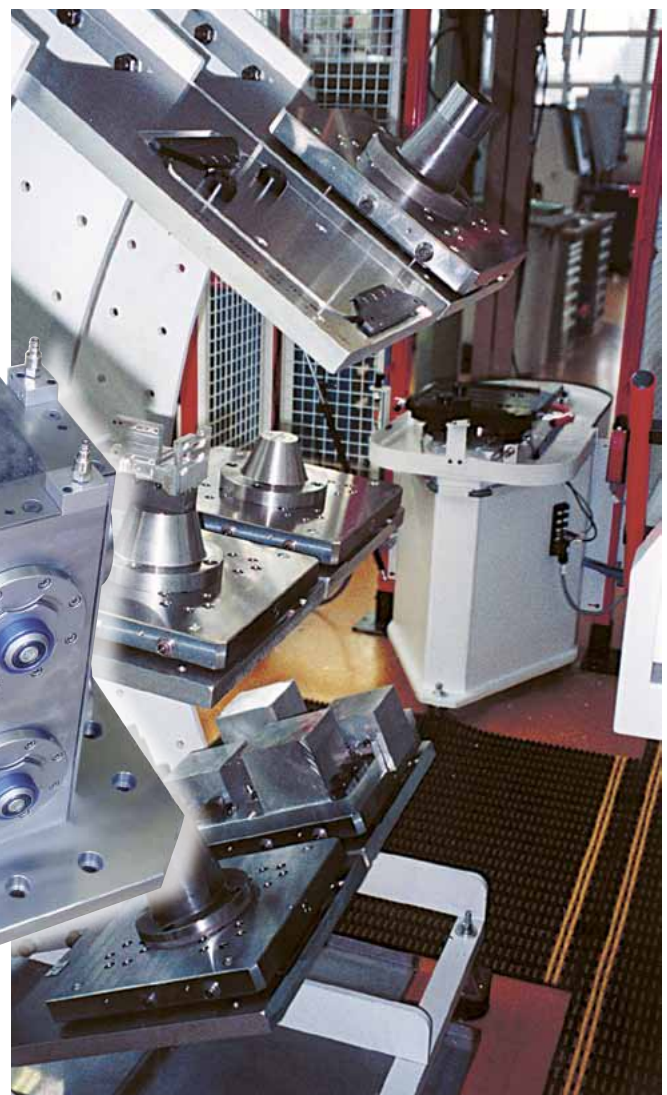

Mehr Informationen siehe Tripoxy Mineral  
For more information check the Tripoxy Mineral p. 272



### Nullpunkt-System OPP & Erowa MTS

In Verbindung mit dem Spannsystem Power Clamp bilden die Nullpunkt-Paletten OPP-Systeme sehr kompakte, hochgenaue und schnell wechselbare Spannvorrichtungseinheiten.

#### Zentrischspanner mit OPP-Anschluss

Das neue mechanische 0-Punktsystem (**OPBM4Q100R50**) findet seine Einsatzmöglichkeiten in allen Bereichen.

Von der einfachen Schnellwechselpalette zur Einzelteilbearbeitung bis hin zur Mehrfachspannung in modernen Fräszentren.

Dank der hohen Wiederholgenauigkeit lassen sich Grossserien problemlos und in höchster Genauigkeit fertigen.

### Zero-point system OPP & Erowa MTS

*Together the modular system with zero point pallets, give a great performance! Fast changing and accurate!*

#### **Self centering vise with integrated zero point adaptation OPP**

*Because of its compact build body this self centering vise gives a perfect performance to automated 5 axis machines!*

*The index zero point system is built into the body of the vise, a sub pallet as you normally mount the vises!*

*The OPP system is a very accurate system reliable and durable! We guarantee 150'000 changes within  $\pm 0,002\text{mm}$*

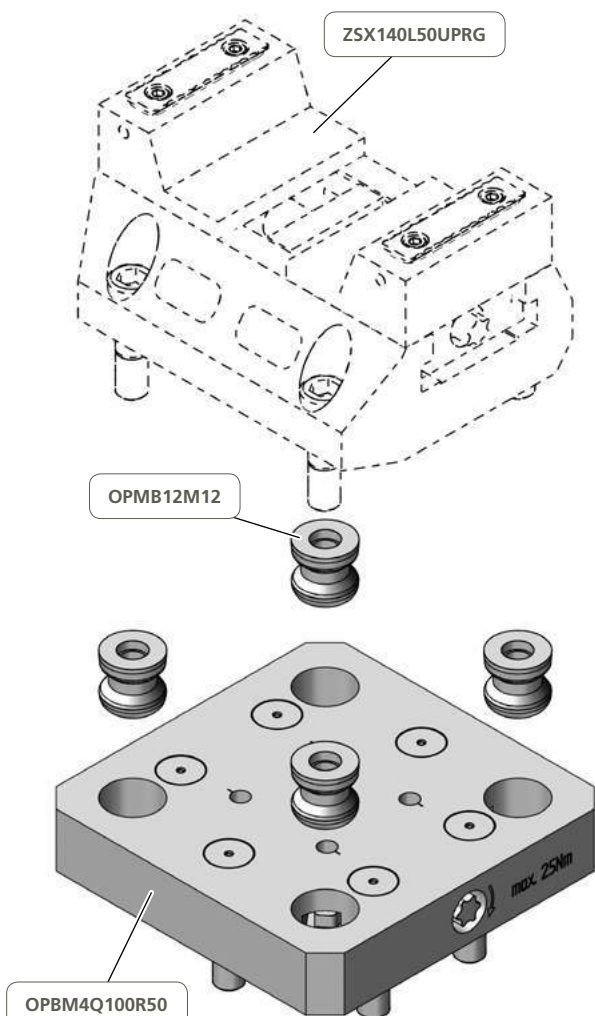



HORIZONTAL







6 PowerCLAMP Basisschiene mit microCLAMP Vorrichtung. Automatisiert mit Erowa Roboter.  
PowerCLAMP baserail with microCLAMP. Automated with Erowa Robot.

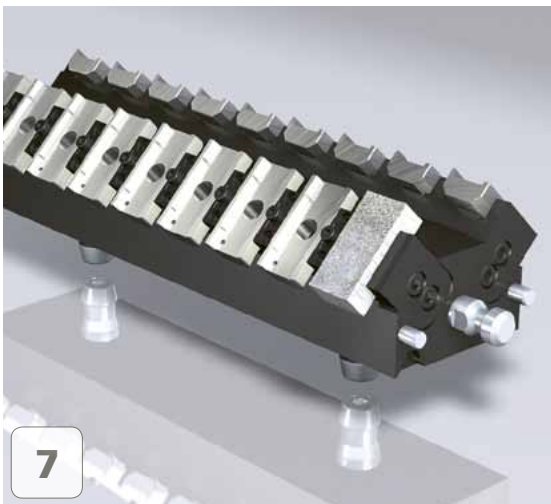

7

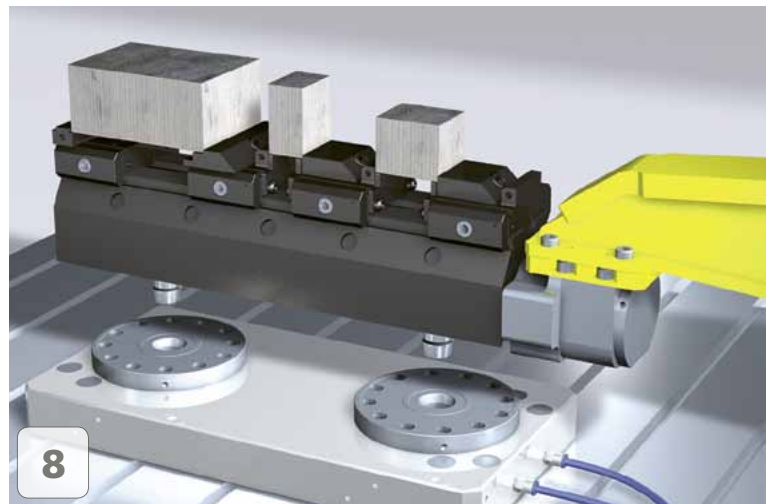

8

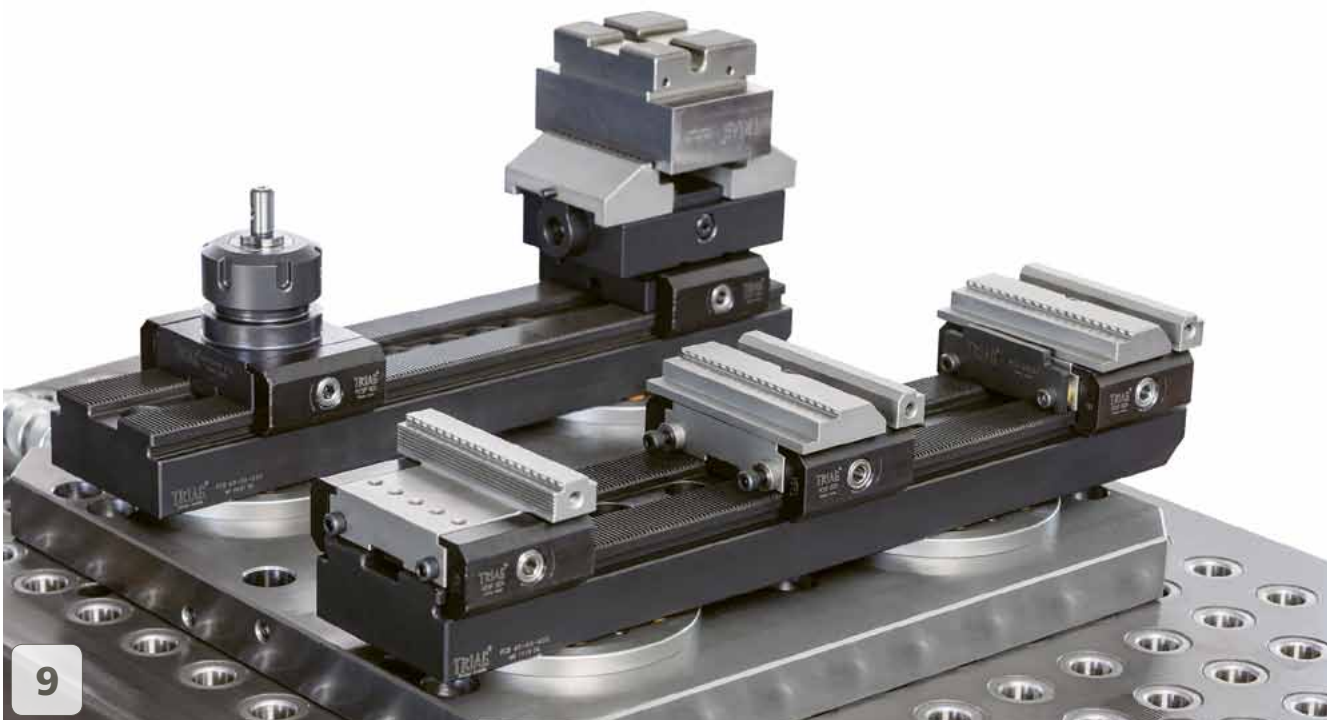

9





# Mechanisches Nullpunktsystem mit diversen Spannlösungen

## Mechanical zero point system with different workholding solutions

Da die Anforderungen an „just in time“ Produktion in den letzten Jahren stetig gewachsen sind, ist ein modulares Nullpunkt Schnellwechselsystem der richtige Weg um lange Standzeiten der Werkzeugmaschine zu verhindern.

Since the requirements for „just in time“ production have grown steadily in the recent years, a modular zero-point quick-change system is the right way to prevent long down time of a machine tool.

- ✓ **Sehr tiefe Bauhöhe (28 mm)**
- ✓ **Wiederholgenauigkeit 0.01 mm**
- ✓ **6000 dAN Haltekraft**
- ✓ **Abhebefunktion ein- und ausschaltbar (3-4 mm)**

- ✓ **Very low height (28mm)**
- ✓ **Repeat accuracy of 0.01mm**
- ✓ **6000daN holding force**
- ✓ **Lift-off function can be switched on and off (3-4 mm)**

**triCENTRO p. 141**

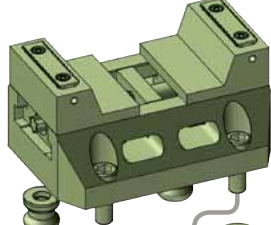

140x120x83

Erhältlich in 4 versch. Größen  
Available in 4 sizes  
140x120x83 / 160x120x83  
180x120x83 / 200x120x83

**triCENTRO p. 119**

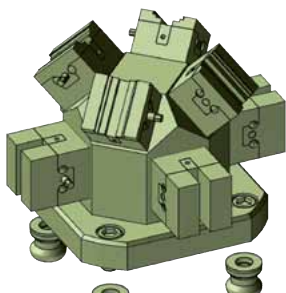

Ø176, H=129

**p. 290**

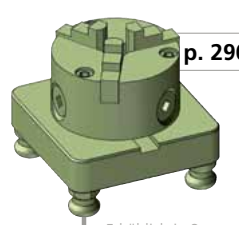

Erhältlich in 3 versch. Größen  
Available in 3 sizes  
Ø 80 / 100 / 125

**3**

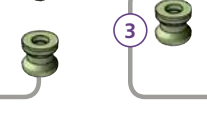

**5**



**10** 250x80x35

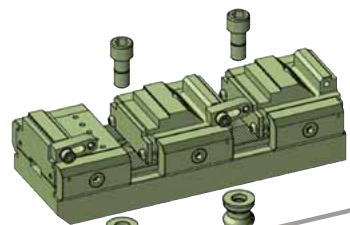

**6** 220x80x35

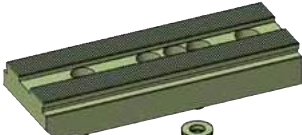

**9** 250x80x35

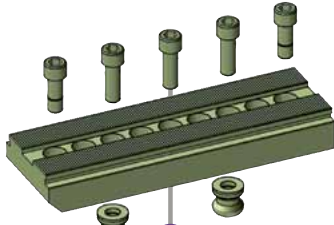

**7** 250x150x40

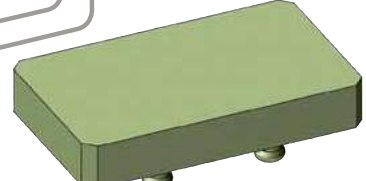

**4** 150x150x44

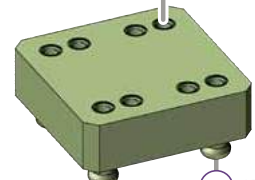

**8** 250x150x28  
R100/M12/12F7

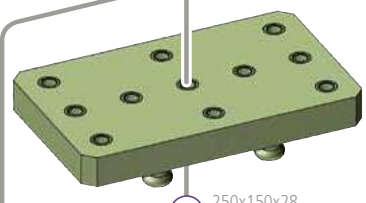

**11** 148x148x4



**A p. 287**

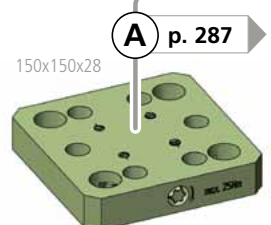

150x150x28

**B p. 288**

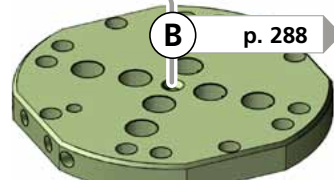

235x235x25

**A**

0-Punkt Basis / 0-point base	
OPBM4Q100R50	~3,8
TB160379	~7,6

**B**

3-Backenfutter / 3-jaw chuck	
OPM3X80L75	~5,8
OPM3X100L82	~7,3
OPM3X125L88	~9,5

Zentrischspanner / Self centering vise	
ZSX140L50UPRG-OPM	~7,1
ZSX160L50UPRG-OPM	~7,7
ZSX180L50UPRG-OPM	~8,1
ZSX200L50UPRG-OPM	~8,8

Erhöhung / Raiser block	
OPUB150H44	~8,5

Sputnik I	
UB5AXMCZ4045SET8-OPBM	~6,2

Basisschiene diagonal / Baserail diagonal	
6 PCSET18220W2-OPM	~8,2

Aluminiumplatte / Aluminium plate	
7 OPM25-15RH40	~4,3

Rasterplatte / Grid plate	
8 OPM25-15R50H28	~7,7

PC Schiene / PC Rail 250 mm	
9 PCB250250-OPM	~4,8

PowerCLAMP Set	
10 PCSET18250-OPM	
1x PCSET18-250A / 03	~5,9
2x PCSET18-L1 / B48-20	~2,65

Abdeckung / Cover	
11 OPMAD	~0,8

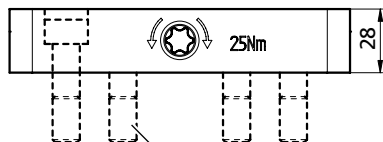
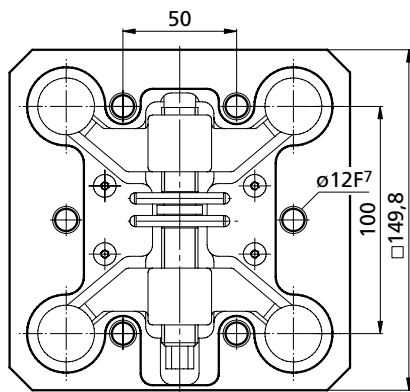

\* Optional erhältlich  
 Optional accessory

p. 289

OPBM4Q100R50	
1	1x TB150065
2	4x <b>OPMB12M12</b>
3	1x TB150068
4	1x TB150069
5	1x OR 14x4
6	4x M5X10DIN7991
7	2x 5m6x40 DIN 6325
8	1x TB150066
9	1x TB150067
10	6x <b>TWPAS1240</b>
11	6x PCPF16L6
12	4x TB150657
13	4x TN100254
kg	~3,8

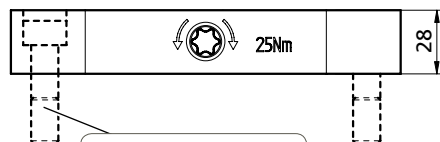
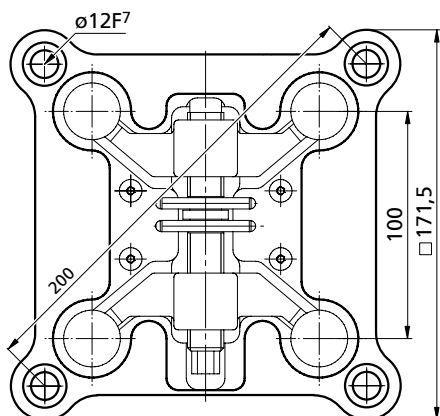
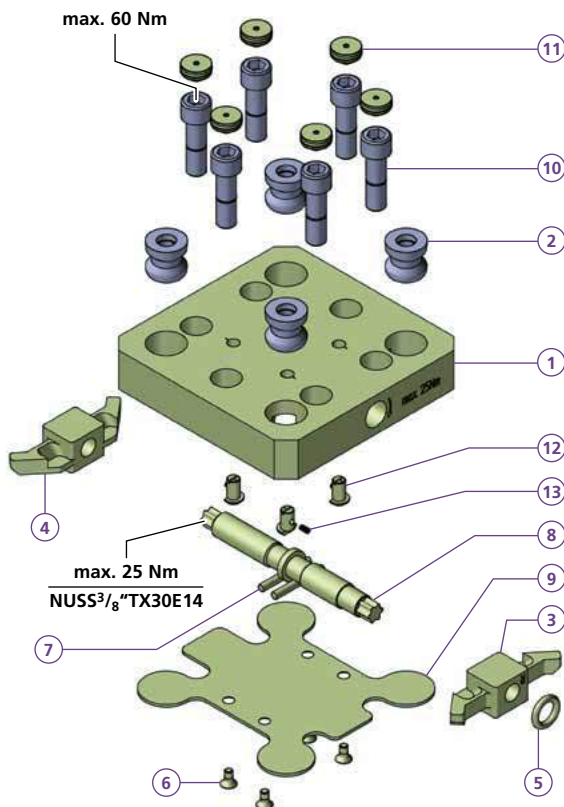

\* Optional erhältlich  
 Optional accessory

p. 289

OPBM4Q100R200	
1	1x TF200958
2	4x <b>OPMB12M12</b>
3	1x TB150068
4	1x TB150069
5	1x OR 14x4
6	4x M5X10DIN7991
7	2x 5m6x40 DIN 6325
8	1x TB150066
9	1x TB150067
10	4x <b>TWPAS1240</b>
11	4x PCPF16L6
12	4x TB150657
13	4x TN100254
kg	~4,27

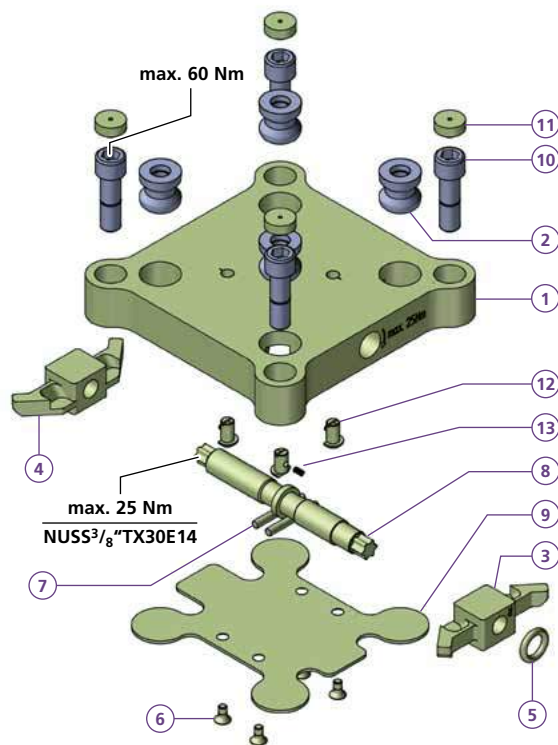

**WICHTIG!**  
 Bitte separat bestellen

**IMPORTANT!**  
 Please order separately

NUSS3/8"TX30E14

Bestellbeispiel / Ordering example:

1x OPBM4Q100R50 & 4x OPMB12M12 4x TWPAS1240 & 1 x NUSS3/8"TX30E14

**0-Punkt Erhöhung**  
**Zero point riser**  
**OPUB150H44**

**0-Punkt Basis**  
**0-point base**  
**TB160379**



**oppSystem**

Optimal kombinierbar mit der Erhöhung (**OPUB150H44**) für eine bessere Zugänglichkeit zum Werkstück.

*Ideally combined with the riser (**OPUB150H44**) for better access to work piece.*

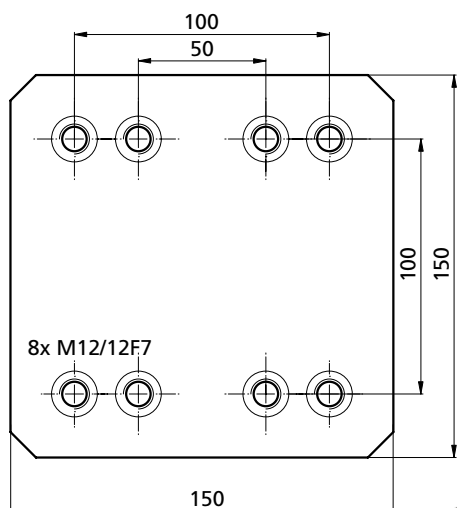
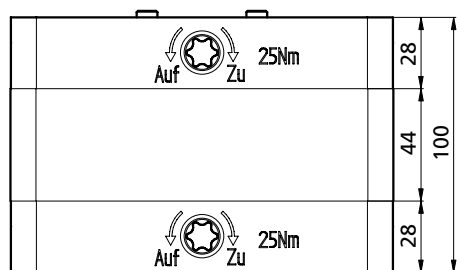

Anwendungsbeispiel mit Zentrischspanner  
*Application example with self centring vise*

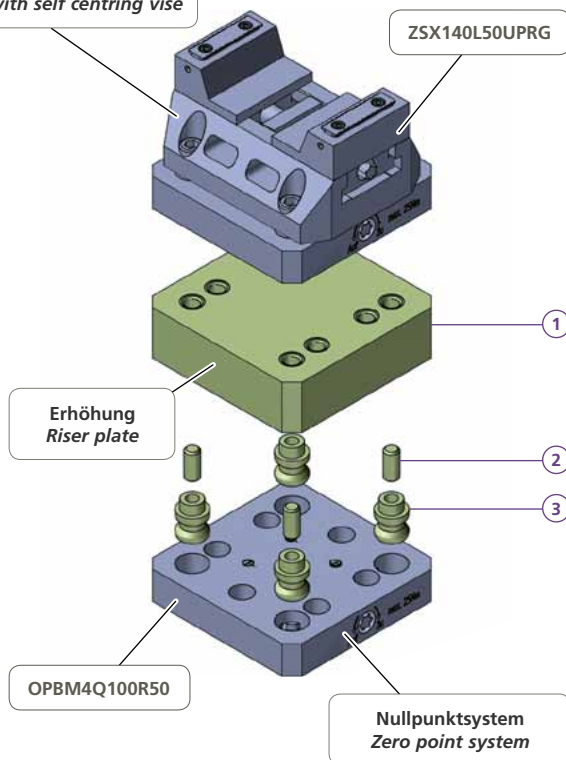

<b>OPUB150H44</b>	
1	1x TB150756
2	4x TN1000067
3	4x OPBM18M12
kg	~8,5

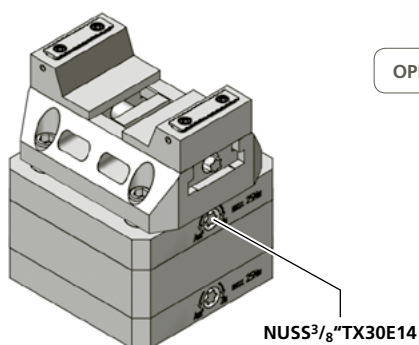

**WICHTIG!**  
 Bitte separat bestellen  
**IMPORTANT!**  
 Please order separately

NUSS<sup>3</sup>/<sub>8</sub>"TX30E14

**Universal Flansch**  
**Universal flange**

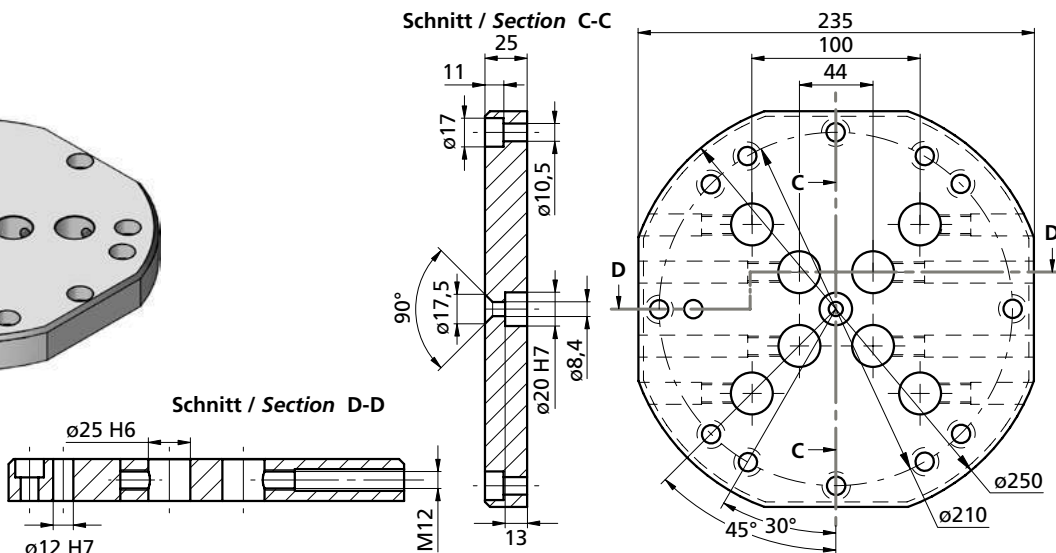
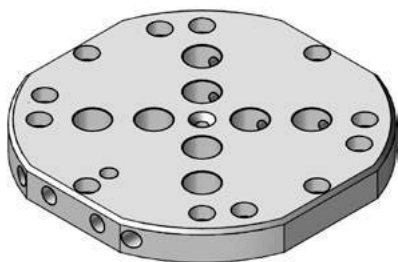

<b>TB160379</b>	
kg	~7,6

Bestellbeispiel / Ordering example: 1 x OPUB150H44 & 2 x OPBM4Q100R50 & 1 x ZSX140L50UPRG & 1 x NUSS<sup>3</sup>/<sub>8</sub>"TX30E14

Separat bestellen / Separate order



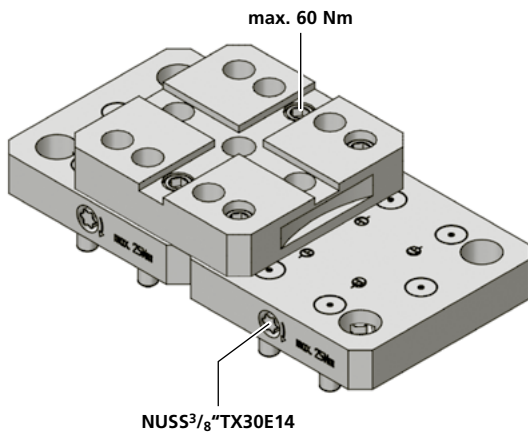
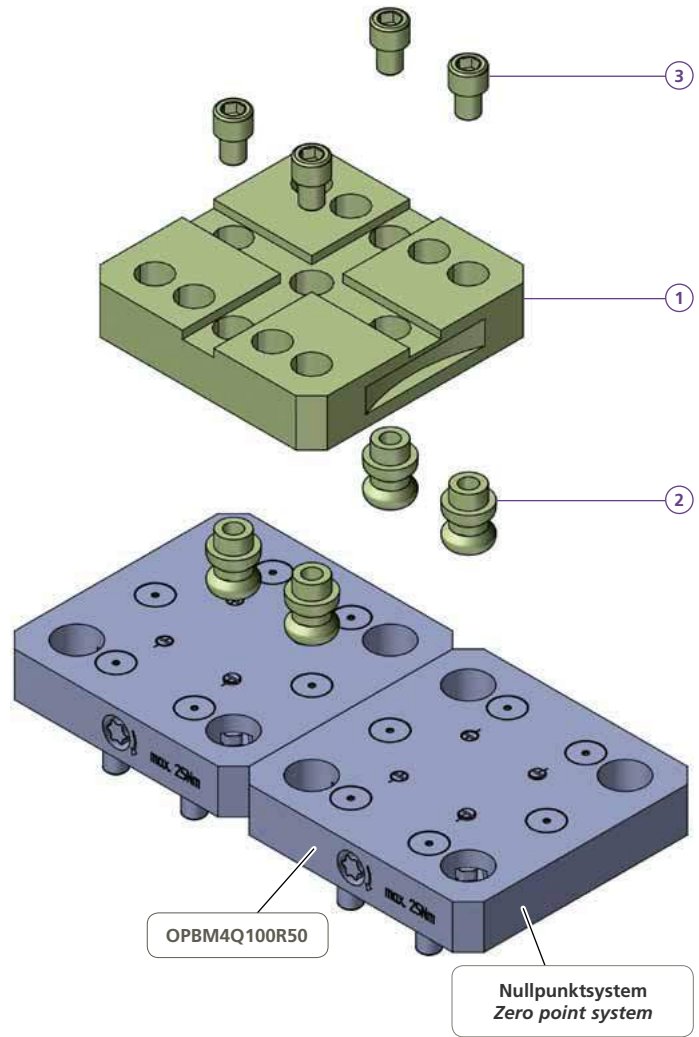
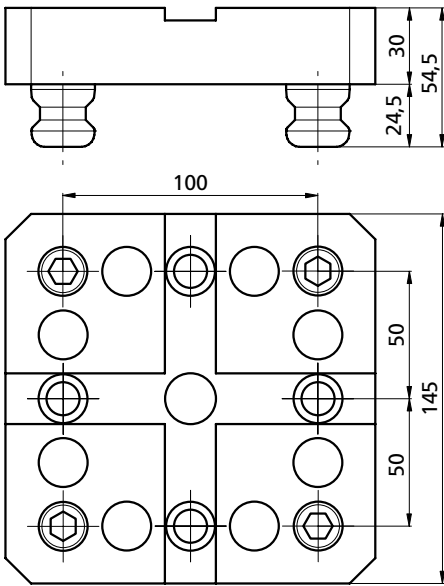

OPMAW	
1	1x TB151141
2	4x OPMB18M12
3	4x M12X16ISO4762
kg	~3,54

**WICHTIG!**  
Bitte separat bestellen

**IMPORTANT!**  
Please order separately

NUSS3/8"TX30E14

Nullpunkt Zentrier- und Klemmbolzen Zero point pull studs	Nullpunkt Schwertbolzen Diamond pull studs	Klemmbolzen mit Untermass Pull studs with minus tolerance	Schuttbolzen Protection bolts
 OPMB18M12 kg -0,1	 OPMB18M12S kg -0,1	 OPMB18M12U kg -0,1	 OPMBL kg ~0,08
 OPMB12M12 kg -0,06	 OPMB12M12S kg -0,06	 OPMB12M12U kg -0,06	 OR ø20x2mm M3 ø25 25,8

Bestellbeispiel / Ordering example : 1x TB160379

Separat bestellen / Separate order

**Dreibackenfutter**  
**Three-jaw chuck**

**OPM3X80L75**  
**OPM3X100L82**  
**OPM3X125L88**



**oppSystem**

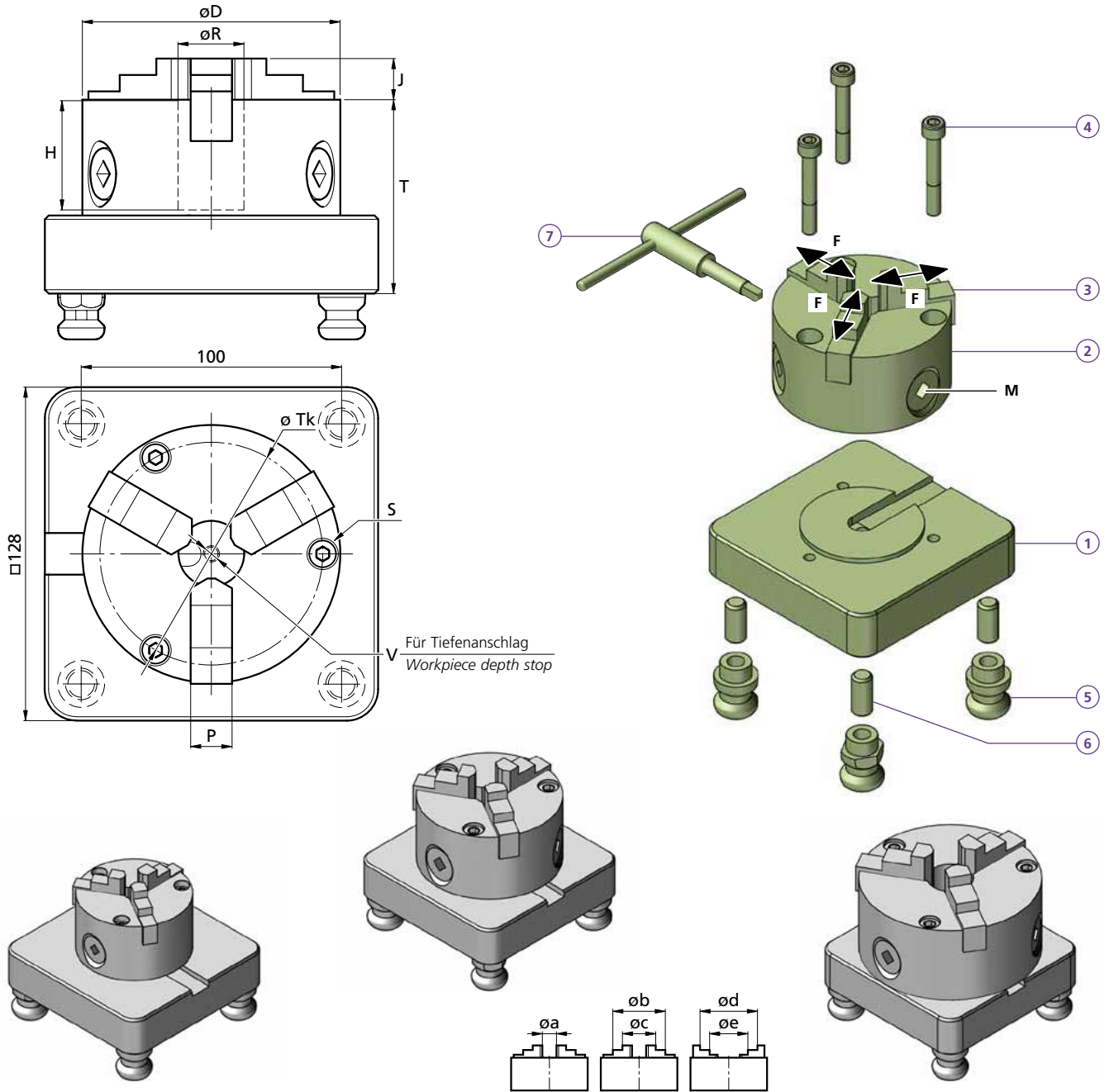

	D	J	T	R	H	P	V	a mm	b mm	c mm	d mm	e mm	M (max.)	F (max.)	$\varnothing Tk$	S
<b>OPM3X80L75</b>	80	13	75	15	42,5	10	M6	3...27	48...73	23...48	52...76	27...51	28 Nm	1300 daN	67	M6
<b>OPM3X100L82</b>	100	17	82	20	49,5	14	M8	3...39	58...94	24...60	64...100	30...66	38 Nm	1600 daN	83	M8
<b>OPM3X125L88</b>	125	19	88	32	55	16	M8	3...49	70...116	30...75	83...125	38...84	55 Nm	2600 daN	108	M8

OPM3X80L75	OPM3X100L82	OPM3X125L88
1 1x TB161207	1 1x TB161208	1 1x TB161209
2 1x 243809.0083220	2 1x 243809.0103220	2 1x 243809.0123220
3 2x 3 Stk. / pcs	3 2x 3 Stk. / pcs	3 2x 3 Stk. / pcs
4 3x TN100346	4 3x TN100360	4 3x TN100361
5 2x OPMB18M12	5 2x OPMB18M12	5 2x OPMB18M12
2x OPMB18M12U	2x OPMB18M12U	2x OPMB18M12U
6 4x TN100067	6 4x TN100067	6 4x TN100067
7 1x 243864.0080000	7 1x 243864.0100000	7 1x 243864.0120000
kg ~ 5,8	kg ~ 7,3	kg ~ 9,5

243849.0083200 243850.0083200 \*243834.0083300

243849.0103200 243850.0103200 \*243834.0103300

243849.0123200 243850.0123200 \*243834.0123300

3x \*Weich Soft 16MnCr5

Separat bestellen / Separate order

Bestellbeispiel / Ordering example: **OPM3X80L75**

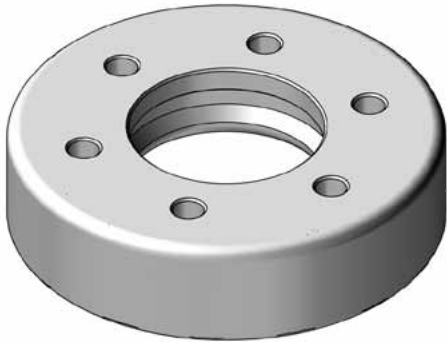

OP92BUE23

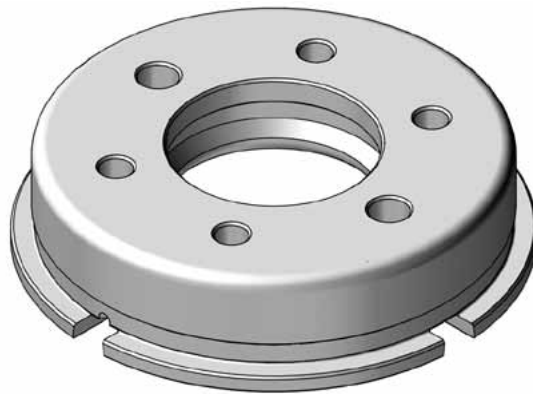

OP92BUE23ID

	kg
OP92BUE23	~0,75
OP92BUE23ID	~0,78

Bestellbeispiel / Ordering example: **OP92BUE23**

**Einbauanleitung / Assembling instructions**

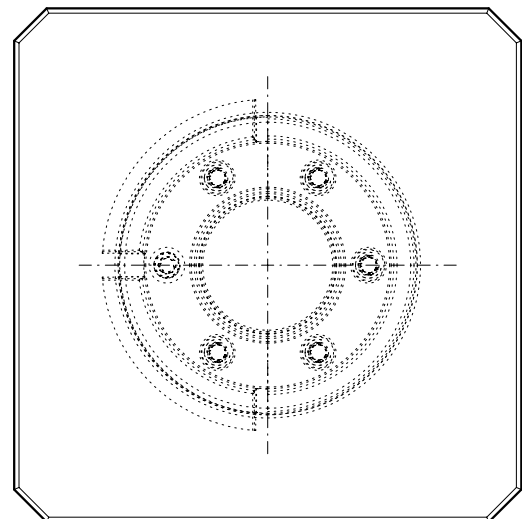
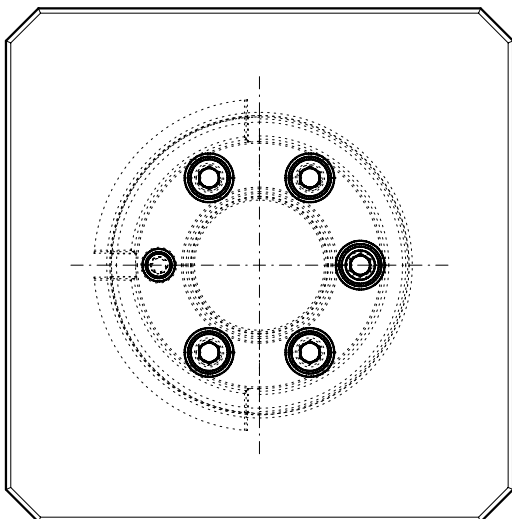
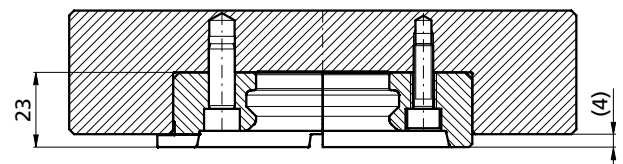
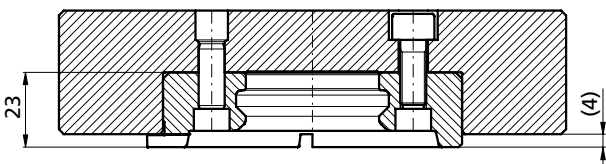
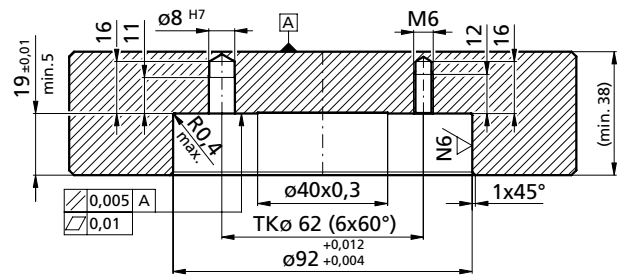
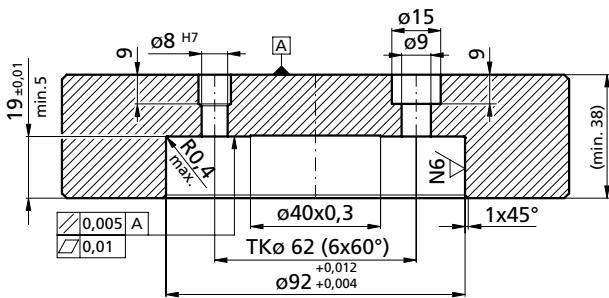



**Zentriereinheit**  
**Chuck unit**

**Zentrierkörper**  
**Chuck body**



**oppSystem**

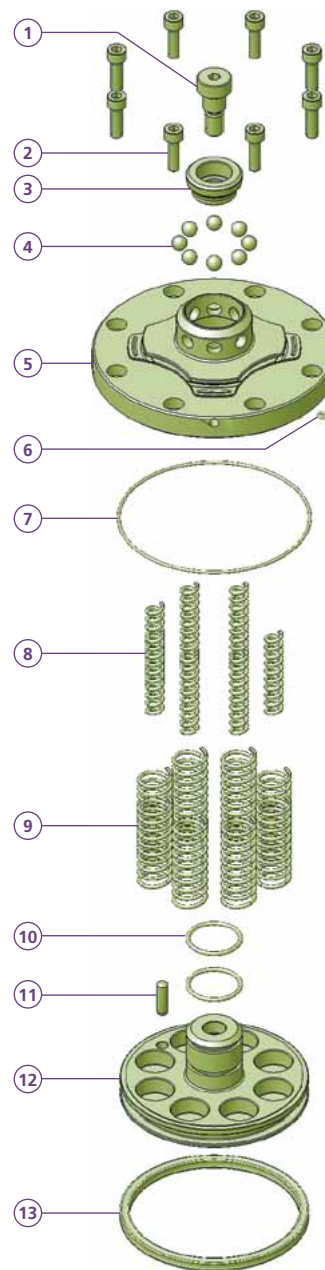
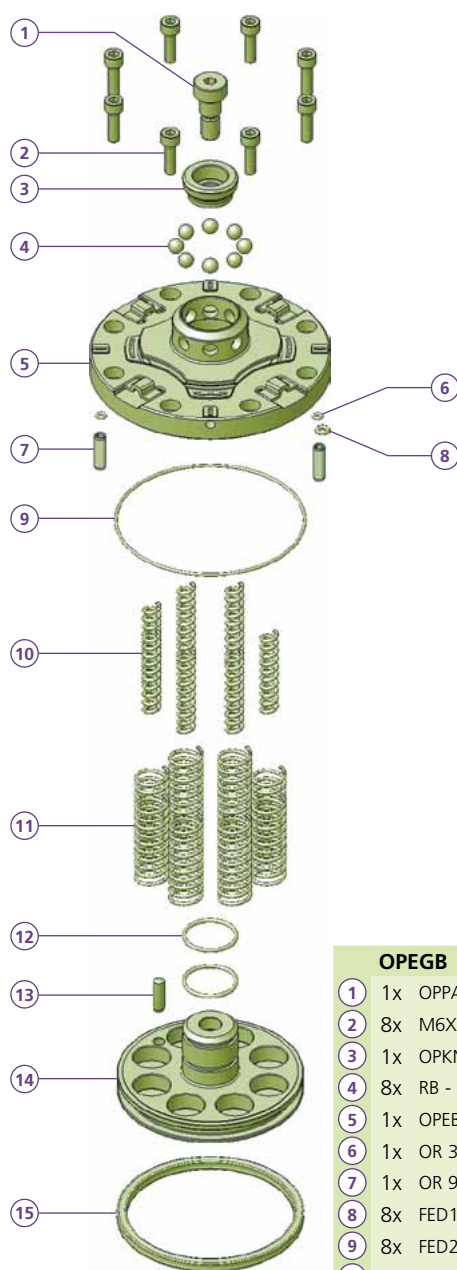

**OPEGBID (Index)**

- ① 1x OPPAS M10x12
- ② 8x M6X20 ST
- ③ 1x OPKN 30x13,5
- ④ 8x RB - 8/G20W
- ⑤ 1x OPEBID
- ⑥ 1x OR 3x1,5
- ⑦ 2x **CCBO0801**
- ⑧ 1x OR 5x1,5
- ⑨ 1x OR 90x1,5
- ⑩ 8x FED1044
- ⑪ 8x FED2051
- ⑫ 2x OR 26x2
- ⑬ 1x 6m6x20 DIN 6325
- ⑭ 1x OPKLB100
- ⑮ 1x OPDR885

kg ~2,28

**OPEGB**

- ① 1x OPPAS M10x12
- ② 8x M6X20 ST
- ③ 1x OPKN 30x13,5
- ④ 8x RB - 8/G20W
- ⑤ 1x OPEB
- ⑥ 1x OR 3x1,5
- ⑦ 1x OR 90x1,5
- ⑧ 8x FED1044
- ⑨ 8x FED2051
- ⑩ 2x OR 26x2
- ⑪ 1x 6m6x20 DIN 6325
- ⑫ 1x OPKLB100
- ⑬ 1x OPDR885

kg ~2,26

**Bestellbeispiel**  
**Ordering example: OPEGBID**

# 1er Palettenträger

## Receiver chuck with 1 chucks



oppSystem

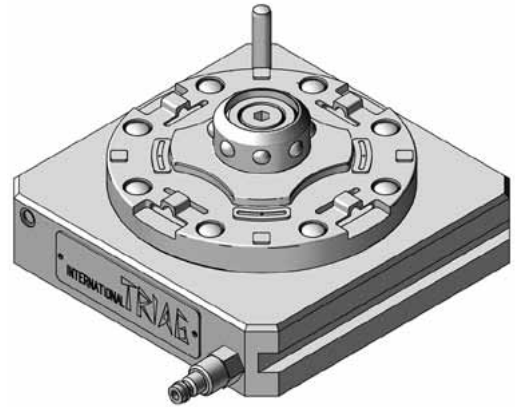
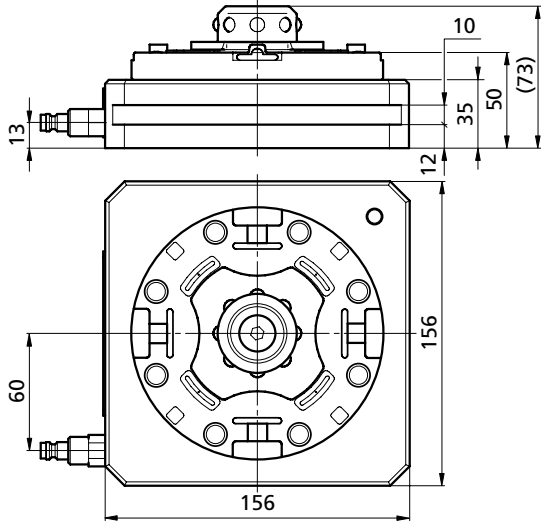

Bestellbeispiel / Ordering example : **OPB1ID**

	kg
OPB1ID (Index)	~8,0

### 1er Palette

#### Pallet with 1 clamping case

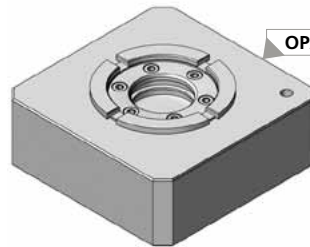
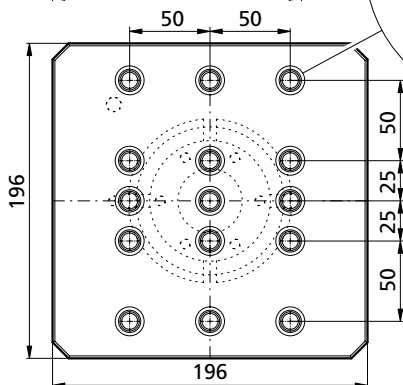
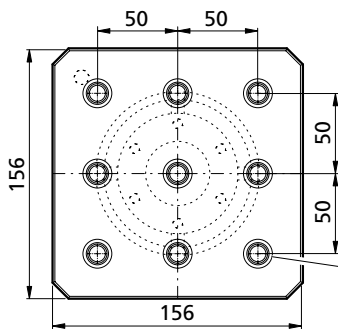
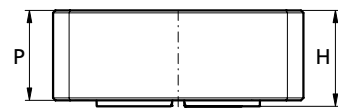

OPA1ID160

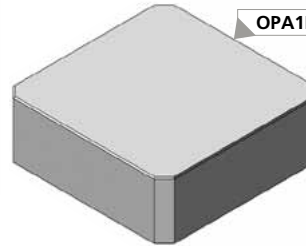

OPA1ID160

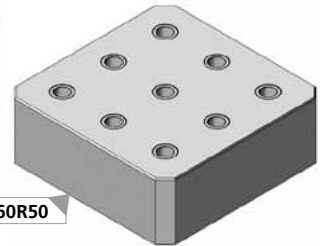

OPA1ID160R50

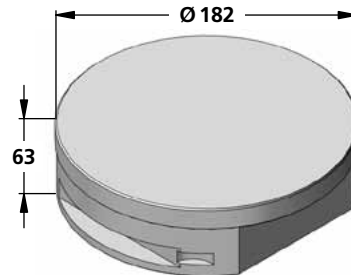
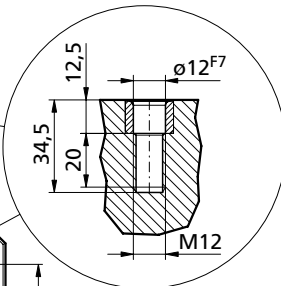

OPA182H63-RS

Bestellbeispiel / Ordering example: **OPA1ID160**

	H	P	kg
OPA1ID160	60,2	56,2	~3,95
OPA1ID200	60,2	56,2	~6,06
OPA1ID160R50	60	56	~4,04
OPA1ID200R50	60	56	~6,12
OPA182H63-RS	= weicher Stahl / soft steel		~11,03

### Basis mit integrierter 0-Punkt Index Aufnahme oppSystem

#### Base rail with integrated oppSystem index

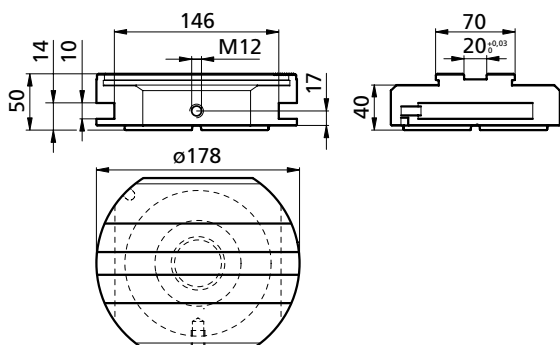

TRIAG oppSystem  
PAROTEC | PARTOOL

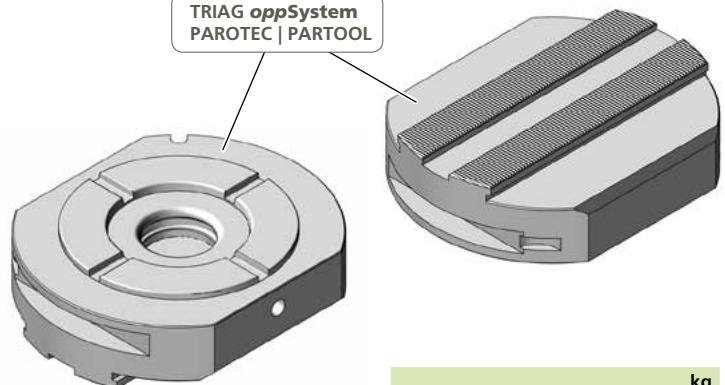

Bestellbeispiel / Ordering example: **OPA1IDPCB178**

	kg
OPA1IDPCBD178	~7,0

# 2er Palettenträger

## Receiver chuck with 2 chucks



oppSystem

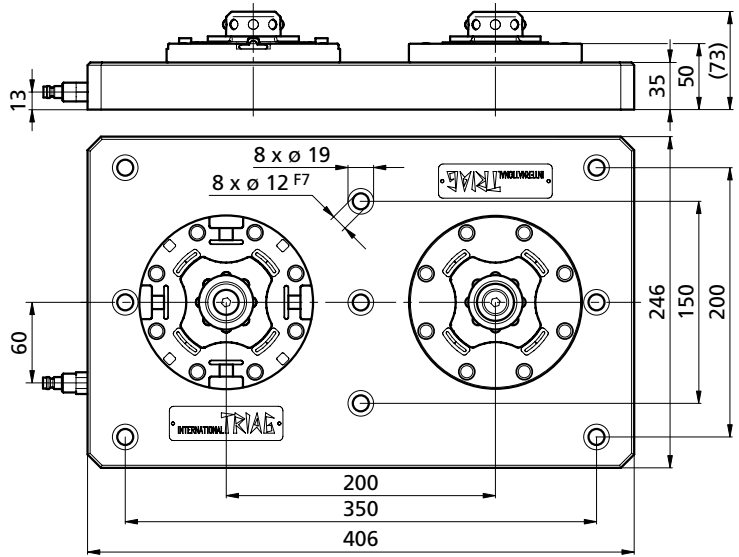
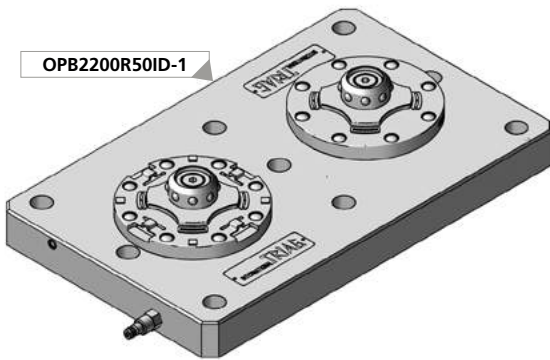
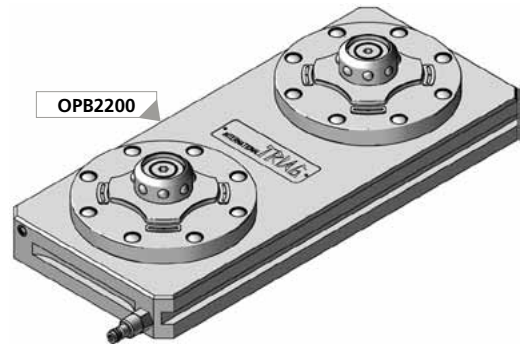
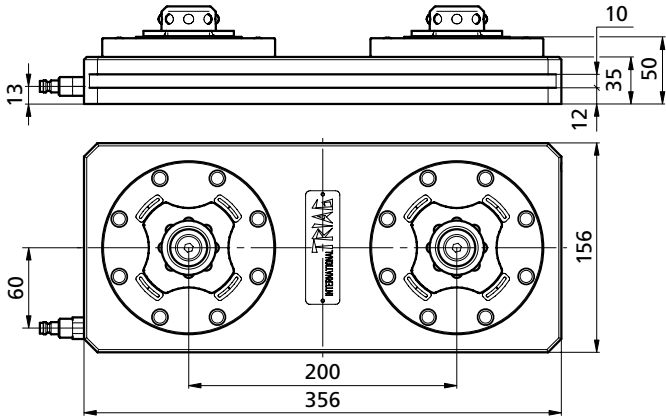

	kg
OPB2200	~17,50
OPB2200R50	~30,00
OPB2200R50ID-1 (Index)	~30,00
OPB2200R50ID-2 (Index)	~30,00

Bestellbeispiel / Ordering example: **OPB2160**

## 2er Palette

### Pallet with 2 clamping case

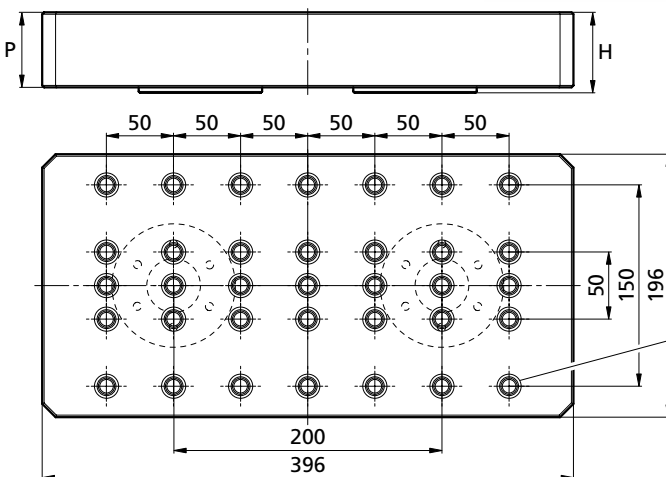
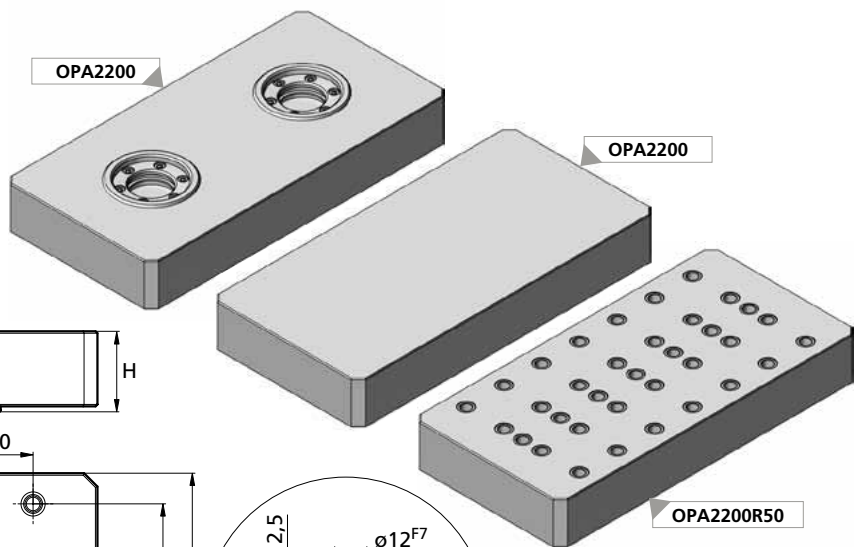

	H	P	kg
OPA2200	60,2	56,2	~12,18
OPA2200R50	60	56	~12,32

Bestellbeispiel / Ordering example: **OPA2200R50**



# 3er Palettenträger

## Receiver chuck with 3 chucks



oppSystem

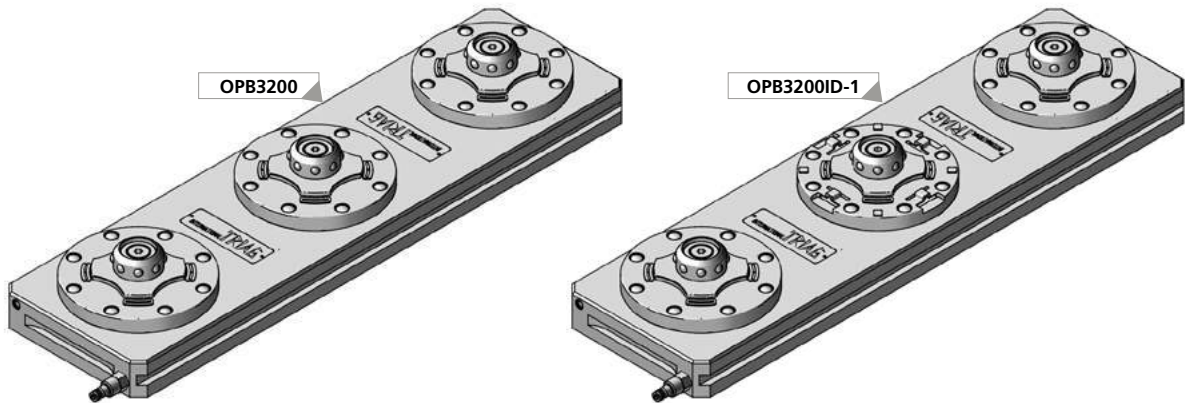
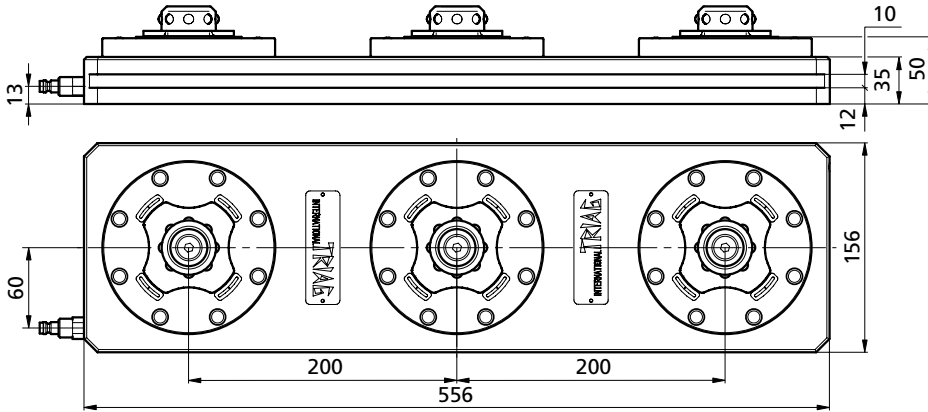

	kg
OPB3200	~27,00
OPB3200ID-1 (Index)	~27,00

Bestellbeispiel / Ordering example: **OPB3200**

### 3er Palette

#### Pallet with 3 clamping case

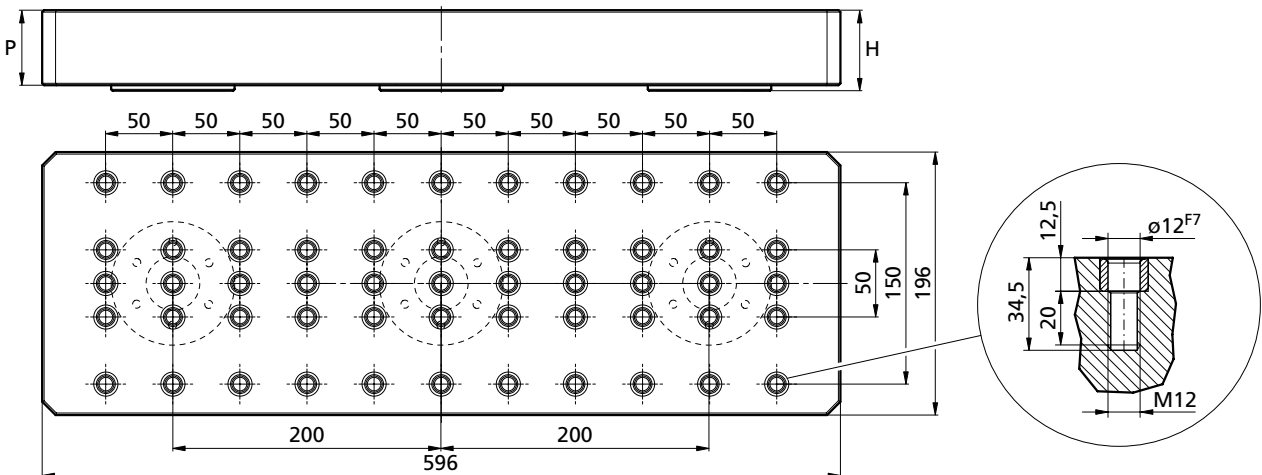
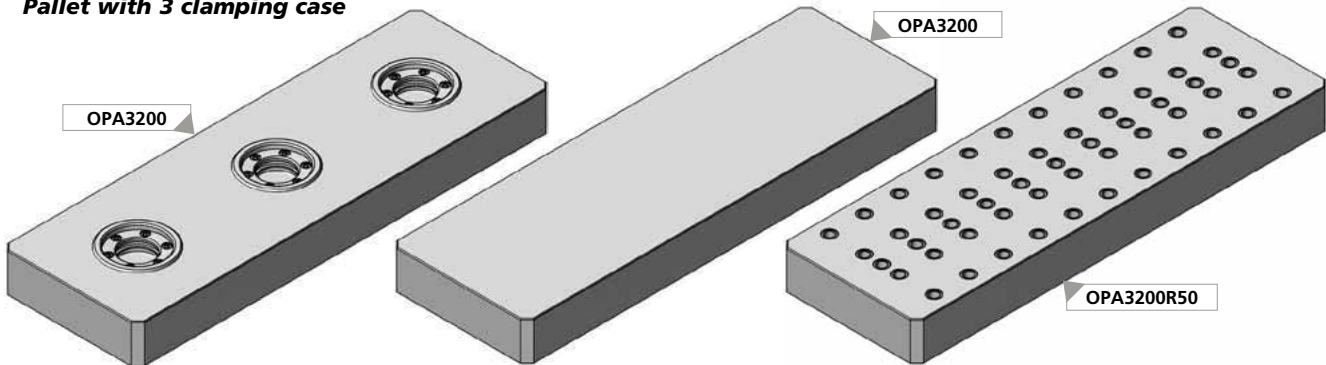

	H	P	kg
OPA3200	60,2	56,2	~18,36
OPA3200R50	60	56	~18,57

Bestellbeispiel / Ordering example: **OPA3200**

# 4er Palettenträger

## Receiver chuck with 4 chucks



oppSystem

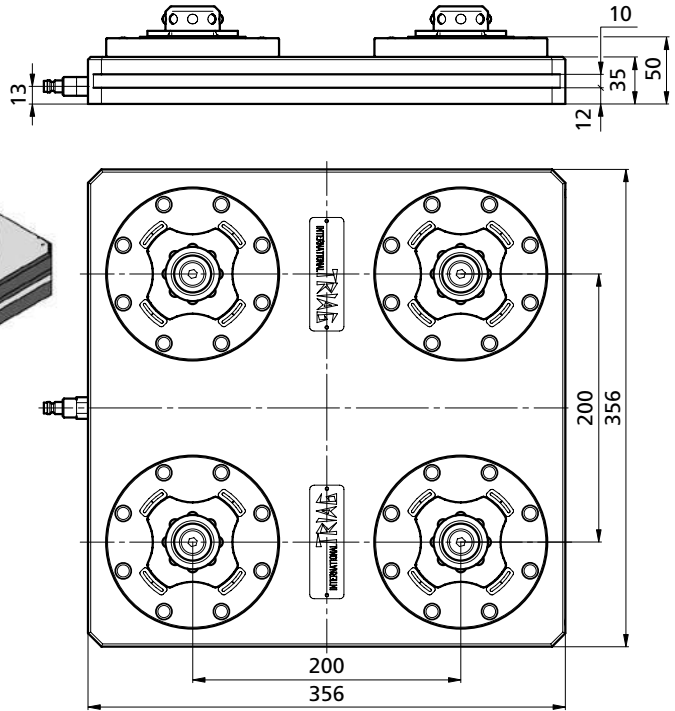

		kg
OPB4Q200		~39,00

Bestellbeispiel / Ordering example: **OPB4Q200**

### 4er Palette

#### Pallet with 4 clamping case

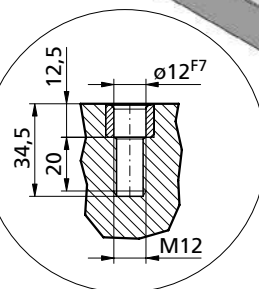
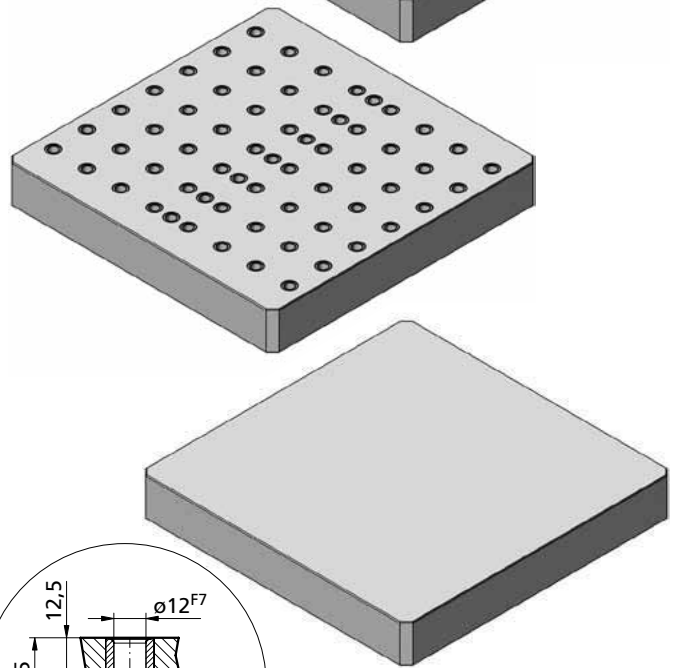
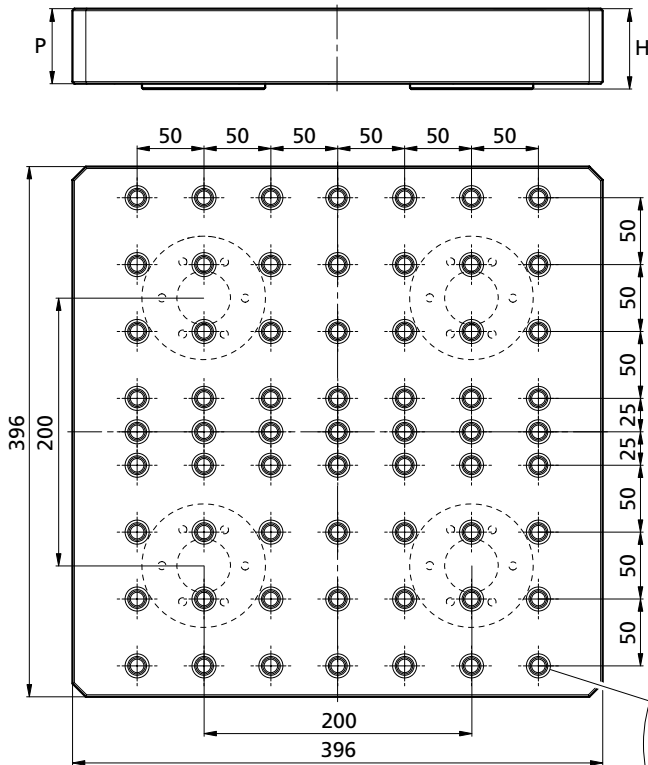
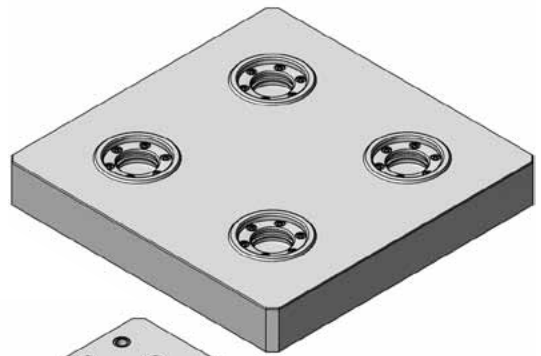

	H	P	kg
OPA4Q200	60,2	56,2	~24,65
OPA4Q200R50	60	56	~24,88

Bestellbeispiel / Ordering example: **OPA4Q200**

**EROWA MTS Einbauspannfutter / Integral chucks**

Einbauvariante (gültig für MTS IntegralChuck Single und Multi). Toleranzen entsprechend der Einbauanleitung beachten!

*Integration variant (applicable to MTS IntegralChucks Single and Multi). Observe tolerances according to integration instructions!*

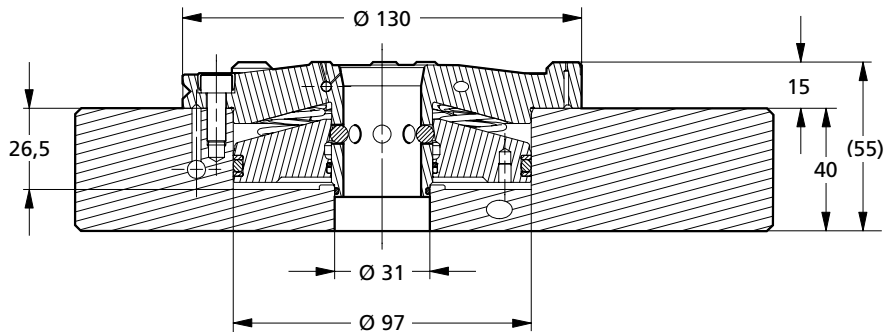

**Manuelle Bedienung**  
*Manual operation*



**Geeignet zur Anwendung unter Flüssigkeit**  
*Suited for submerged operation*



**Geeignet für automatische Anwendung**  
*Suited for automatic operation*



**Mit Druckluftpistole bedienen**  
*Operate with compressed air jet*



**Für spanabhebende Bearbeitung**  
*For chip-removing processes*



**Zum Senkerodieren**  
*For EDM sinking*

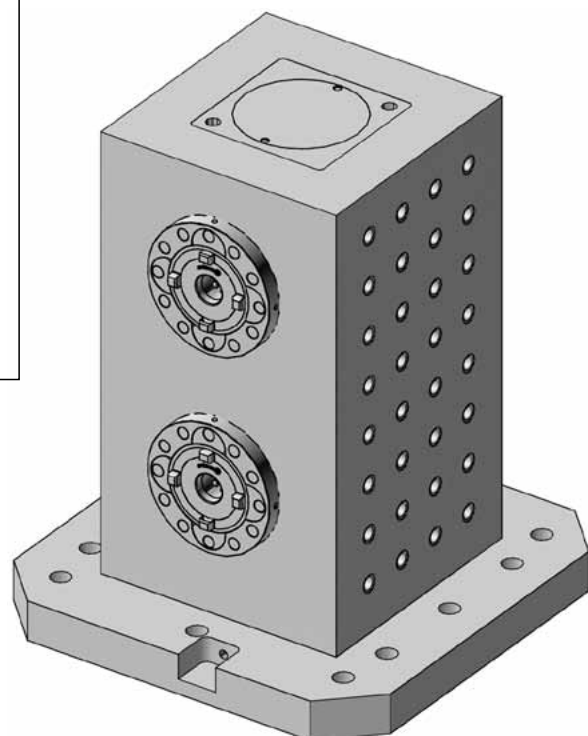





**1 Präzise**

Spielfreie Kurzkegel-Zentrierung.  
 Repetiergenauigkeit: < 0,005 mm.  
 Leichtes Einfahren der Paletten.

**2 Spannmechanismus**

Zuverlässiger Spannmechanismus durch selbsthemmenden Kugelverschluss.

**3 Öffnen**

MTS Spannfutter werden pneumatisch betätigt.

**4 Sauberkeit**

Flüssigkeit kann ablaufen, keine Schmutzecken.

**1 Precise**

Play-free round-cone centering.  
 Repeatability: <0.005 mm.  
 Easy insertion of the pallets.

**2 Clamping mechanism**

Reliable clamping mechanism through self-locking ball lock.

**3 Open**

MTS are operated pneumatically.

**4 Cleanliness**

Liquids can drain off. No dirt traps.

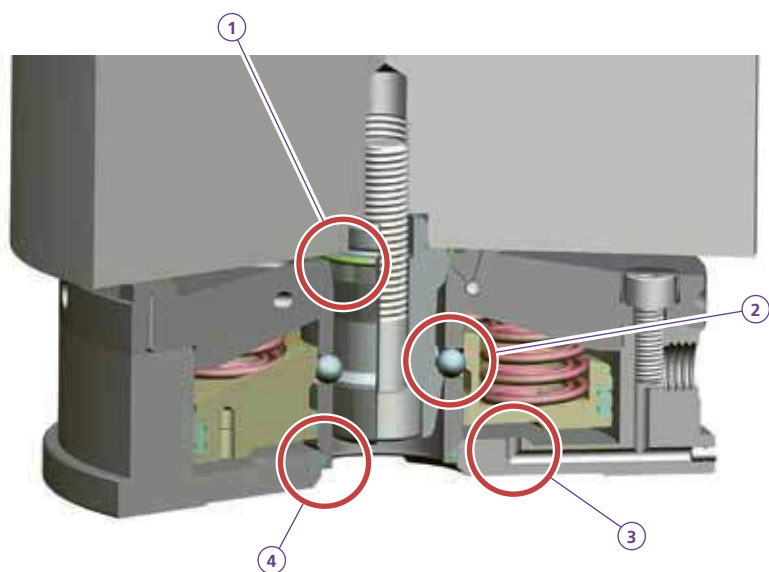

**L x B x H:** Maschinenabhängig  
**L x W x H:** Depending on the machine

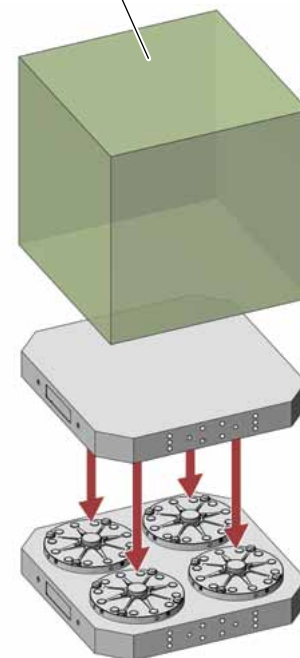

**MTS Spannfutter**

Das pneumatische MTS Spannfutter benötigt trotz der hohen Spannkraft von 12'000 N dank interner Kraftverstärkung nur 7 bar Öffnungsdruck.

**MTS Chuck**

A mere 7 bar of opening pressure results in 12,000 N clamping power thanks to internal power boosting.

**MTS Spannfutter, automatisierbar**

Automatische Reinigung der Auflageflächen und des Zentrierzapfens beim Werkstückwechsel.

**MTS chuck, automatable**

Automatic cleaning of contact surfaces and of the centering spigot cone while the workpiece is changed.

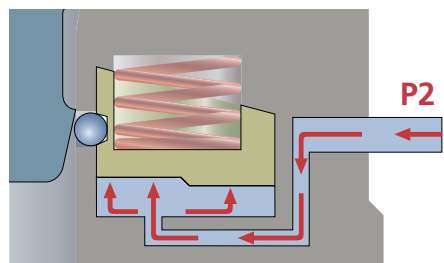

**P2 Anschluss (P2)**  
 Öffnen  
**Prise (P2)**  
 Ouverture

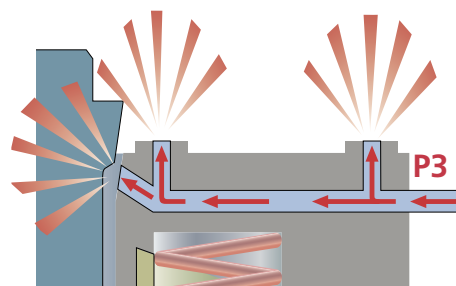

**P3 Anschluss (P3)**  
 Reinigen  
**Prise (P3)**  
 Cleaning

### MTS IntegralChuck S-P (single + multiple / manually)

ER-033402



- Ausführung** Für den direkten Einbau in Maschinentische, Platten, Spanntürme, Winkel oder Teilapparate.
- Anschlüsse** Zum Öffnen: Pneumatisch.
- Anwendung** Zur Aufnahme von Einzel- oder Mehrfachpaletten.
- Version** For direct integration in machine tables, plates, tombstones, squares or dividing heads.
- Connections** To open: pneumatic or hydraulic.
- Application** To accommodate single or multiple pallets.

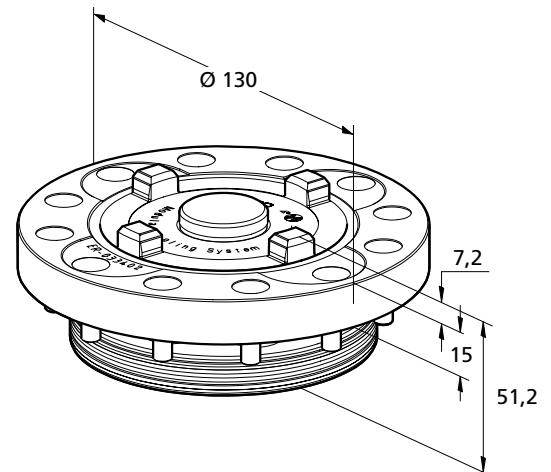

### MTS IntegralChuck S-P/A (single + multiple / auto)

ER-036802



- Ausführung** Für den direkten Einbau in Maschinentische, Platten, Spanntürme, Winkel oder Teilapparate.
- Anschlüsse** Zum Öffnen: Pneumatisch.  
Zum Reinigen: Pneumatisch.
- Anwendung** Zur Aufnahme von Einzel- oder Mehrfachpaletten.
- Version** For direct integration in machine tables, plates, tombstones, squares or dividing heads.
- Connections** To open: pneumatic.  
To clean: pneumatic.
- Application** To accommodate single or multiple pallets.

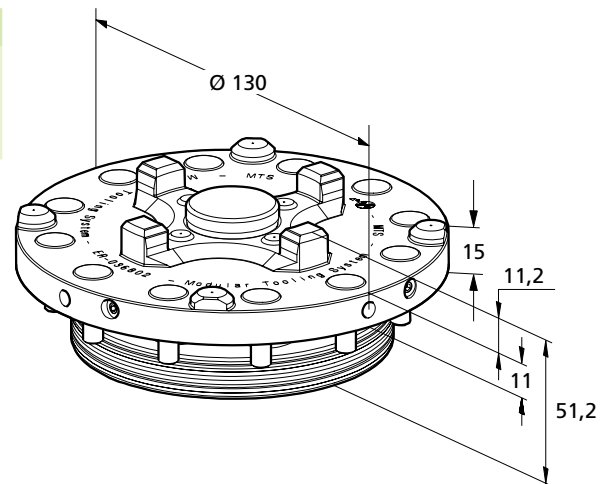

Spannzapfen / Spigot		
ER-033800	manuell / 0-Punkt Zapfen manually zero point locating	
ER-039201	auto / Ausgleichszapfen auto / alignment spigot	
ER-039200	auto / Zapfen mit Spiel auto / spigot with clearance	
ER-038000	auto / 0-Punkt Zapfen auto / Zero point spigot	

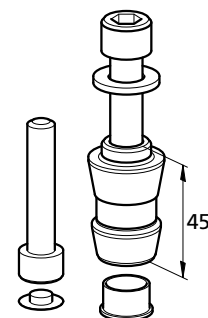

Um Ihnen die schnelle Orientierung über die Anwendungsbereiche der EROWA Produkte zu erleichtern, verwenden wir die folgenden Zeichen:

To make it easier for you to find your way about the fields of application for EROWA products, we use the following symbols:

- S** = Single  
**M** = Multi  
**A** = Automatisierbar / Able to automate  
**P** = Pneumatisch betätigt / Pneumatically operated

- Manuelle Bedienung  
Manual operation
- Geeignet zur Anwendung unter Flüssigkeit  
Suited for submerged operation
- Geeignet für die automatische Anwendung  
Suited for automatic operation
- Für spanabhebende Bearbeitung  
For chip-removing processes
- Zum Senkerodieren  
For EDM sinking

**MTS IntegralChuck M-P (multiple / manually)**

ER-033400



- Ausführung** Für den direkten Einbau in Maschinentische, Platten, Spanntürme, Winkel oder Teilapparate.
- Anschlüsse** Zum Öffnen: Pneumatisch.
- Anwendung** Zur Aufnahme von Einzel- oder Mehrfachpaletten.
- Version** For direct integration in machine tables, plates, tombstones, squares or dividing heads.
- Connections** To open: pneumatic or hydraulic.
- Application** To accommodate single or multiple pallets.

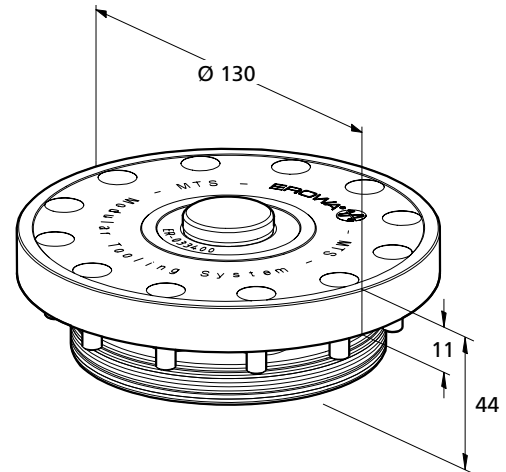

**MTS IntegralChuck M-P/A (multiple / auto)**

ER-036800



- Ausführung** Für den direkten Einbau in Maschinentische, Platten, Spanntürme, Winkel oder Teilapparate.
- Anschlüsse** Zum Öffnen: Pneumatisch.  
Zum Reinigen: Pneumatisch.
- Anwendung** Zur Aufnahme von Einzel- oder Mehrfachpaletten.
- Version** For direct integration in machine tables, plates, tombstones, squares or dividing heads.
- Connections** To open: pneumatic.  
To clean: pneumatic.
- Application** To accommodate single or multiple pallets.

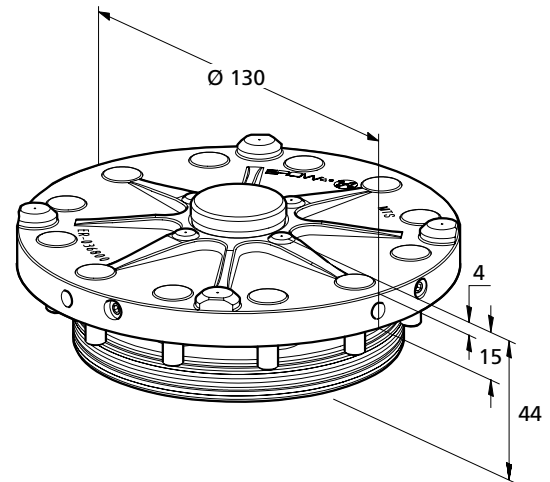

Spannzapfen / Spigot		
ER-033800	manuell / 0-Punkt Zapfen manually zero point locating	
ER-039201	auto / Ausgleichszapfen auto / alignment spigot	
ER-039200	auto / Zapfen mit Spiel auto / spigot with clearance	
ER-038000	auto / 0-Punkt Zapfen auto / Zero point spigot	

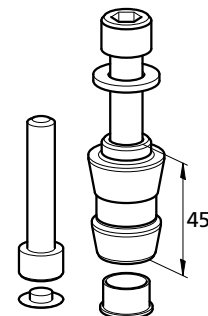

Um Ihnen die schnelle Orientierung über die Anwendungsbereiche der EROWA Produkte zu erleichtern, verwenden wir die folgenden Zeichen:



To make it easier for you to find your way about the fields of application for EROWA products, we use the following symbols:

- S** = Single  
**M** = Multi  
**A** = Automatisierbar / Able to automate  
**P** = Pneumatisch betätigt / Pneumatically operated

- Manuelle Bedienung  
Manual operation
- Geeignet zur Anwendung unter Flüssigkeit  
Suited for submerged operation
- Geeignet für die automatische Anwendung  
Suited for automatic operation
- Für spanabhebende Bearbeitung  
For chip-removing processes
- Zum Senkerodieren  
For EDM sinking



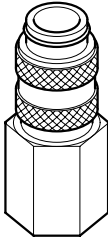
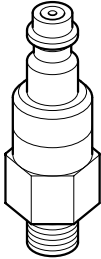

<b>OPSKU</b>	G1/4" Innengewinde <i>Internal thread</i>	<b>OPST-NI</b>	G1/8" Aussengewinde <i>Male thread</i>	<b>OPRV</b>	G1/8" Aussengewinde <i>Male thread</i>
 Schnelkupplung <i>Quick fitting coupling</i>		 Stecknippel verschmutzungsgeschützt <i>Plug nipple protected against staining</i>		 Rückschlagventil <i>Nonreturn valve</i>	
<b>OPANS-8</b> G1/4" Aussengewinde <i>Male thread</i>					

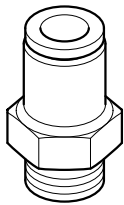

Für 8 mm Schlauch / *For hose*

**Abdeckung**  
**Cover**

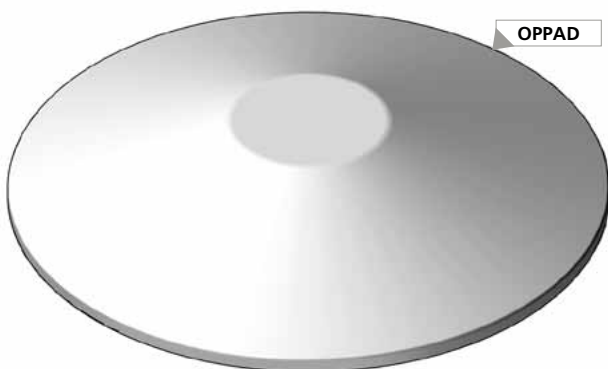

**Dichtlippe**  
**Leakproof cover**

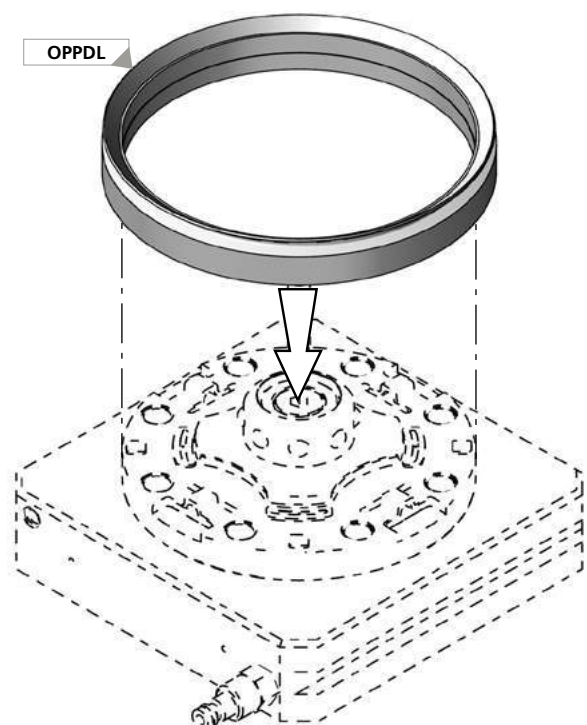

	<b>kg</b>
<b>OPPDL</b>	~0,525
<b>OPPDL</b>	~0,075

Bestellbeispiel / *Ordering example* : 1x **OPPDL**



oppSystem

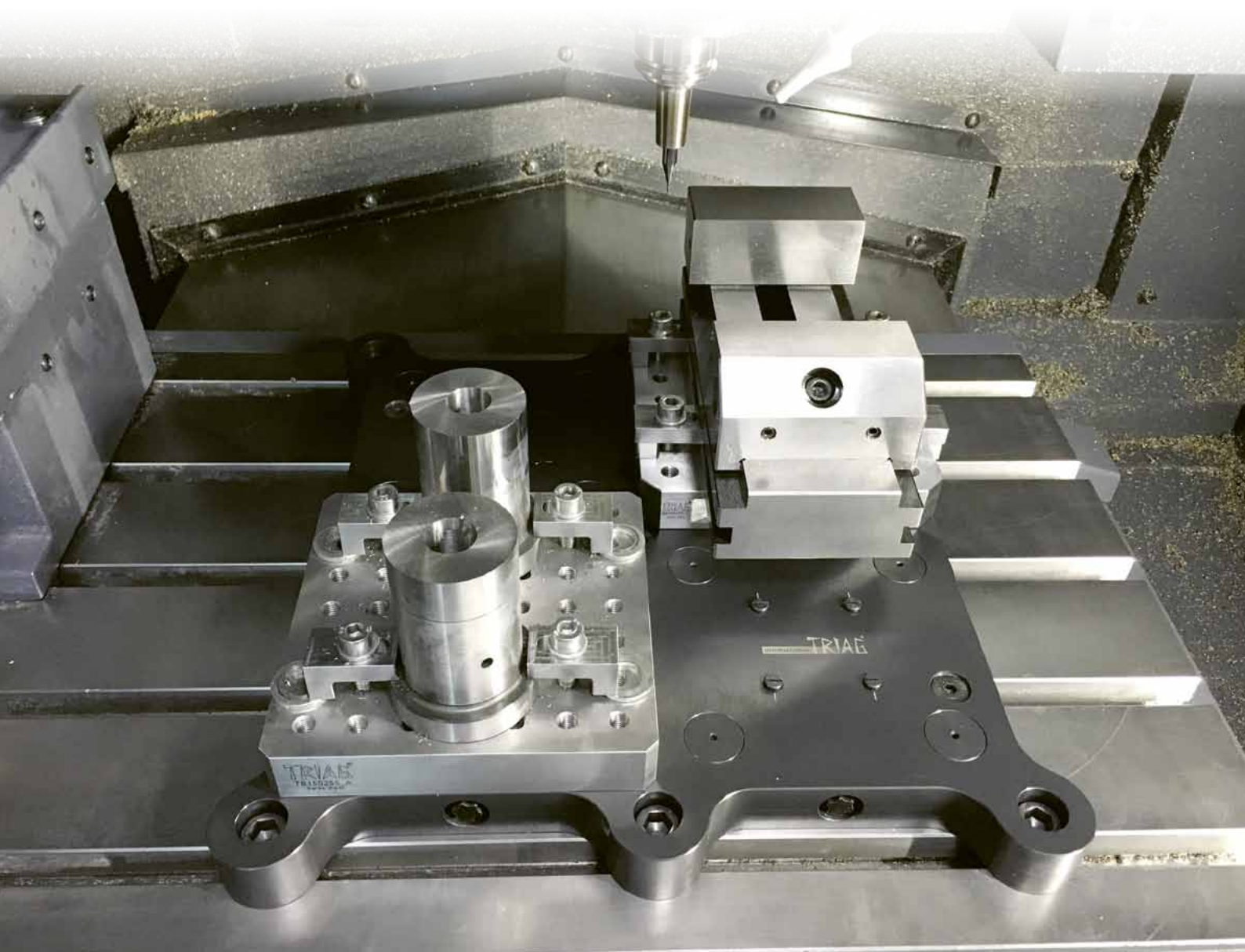

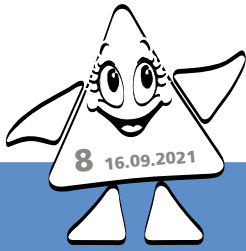

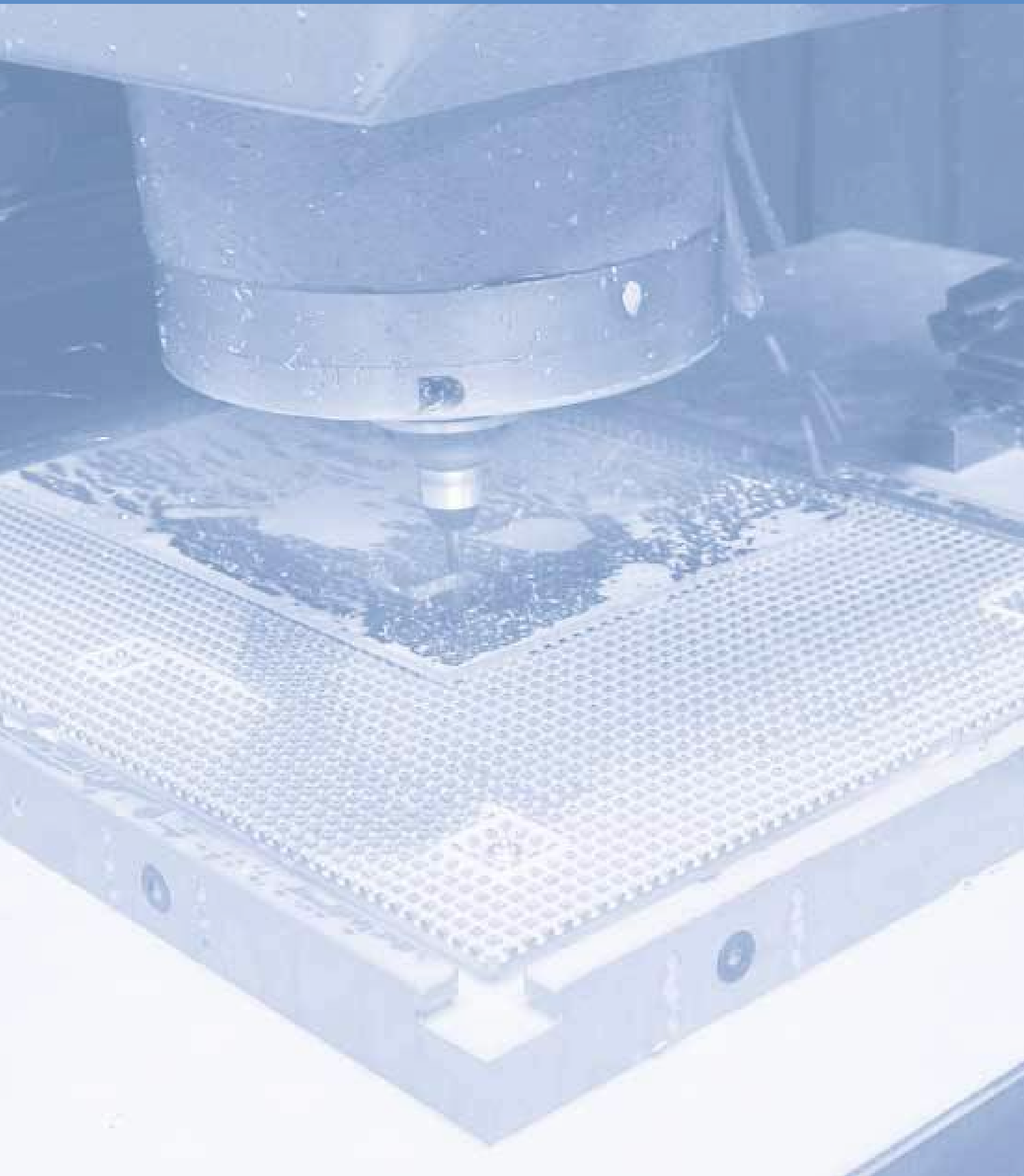

**triva**CLAMP





 **Einleitung | Introduction** ..... 305 - 307

 **Bedienungsanleitung | Operating manual** ..... 308 - 309

**Anwendungsbeispiele | Examples of application** ..... 310 - 312

**Modulare Vakuumplatten | Modular vacuum plates** ..... 314 - 317

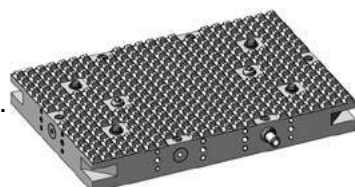

**Vakuum-Modul für powerCLAMP | Vacuum module for powerCLAMP** ..... 318 - 319

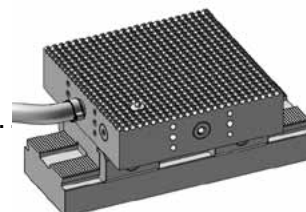

**Kombinationsvarianten (Vakuumplatten) | Possible combination of vacuum plates** ..... 320

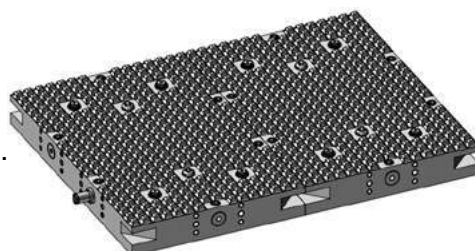

**Startersets nach Ihrer Wahl | Starter kit (Your choice)** ..... 321

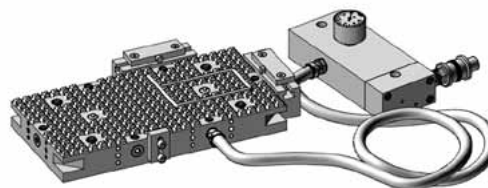

**Zubehör | Accessories** ..... 322 - 324



**Vakuum erzeugen | Generate vacuum** ..... 325 - 327

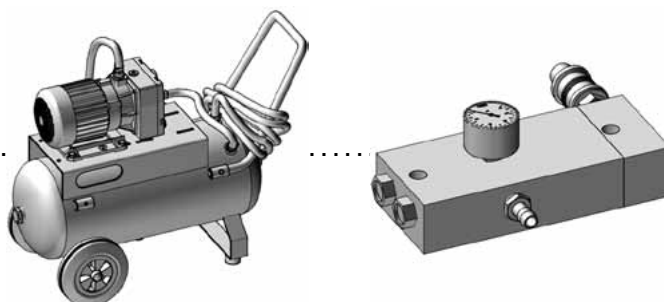

### Vakuumspannen

Die mechanische Spannung hat bekanntlich auch Nachteile. Hohe Kräfte auf das Werkstück können zu Druckmarken und Verformungen führen. Vor allem bei grösseren Werkstücken besteht zudem die Gefahr, dass das Werkstück vibriert.

### Workholding by vacuum

*Mechanical clamping, as described before, has disadvantages. High specific forces on the workpiece can cause pressure marks and distortions. And, particularly on large parts, there is a risk that the workpiece will vibrate.*



Bei der Spannung mit Vakuum wird der Druck nicht mechanisch auf das Werkstück sondern durch die umgebende Atmosphäre ausgeübt. Dadurch werden die Werkstücke schonend und gleichmässig über die ganze Auflagefläche fixiert, so dass kaum Vibrationen entstehen.

Der Beschickungs- und Arbeitsraum bleibt zudem frei von Briden und Spannmittel.

*In vacuum clamping the clamping force is not applied to the work piece mechanically, but is provided by the surrounding atmosphere. This means that the work piece is gently and evenly pulled down over the whole supporting surface, so that vibration is minimized. As there are no obstructing brackets, clamps or workholding modules in the working and loading area, there are fewer chances for collisions with the tool.*

► **Diese Spannmethode ist vor allem für grossflächige, dünnwandige, auch nichtmagnetische Werkstücke geeignet.**

► **This clamping method is particularly suitable for large surface, thin-walled and also non magnetic work pieces.**

**Triva Clamp besteht aus folgenden Funktionsteilen:**

**Triva Clamp consists of the following functional devices:**

- **Vakuumpplatten** mit passenden Anschlagleisten für den Einsatz mit seitlich einwirkenden Kräften.
- **Dichtschnur aus Silikongummi**, die immer entlang der Peripherie des Werkstücks eingelegt wird. Die Haltekraft wächst proportional zur Aufspannfläche, die durch die Dichtschnur begrenzt wird.
- **Rotations-Vakuumpumpe** mit Schaltventil und Druckwächter optional.
- **Injektorpumpe** mit Schaltventil.

- **Vacuum plates** with suitable stop gauges for application with lateral workholding forces.
- **Silicone-rubber sealing cord** inlaid along the periphery of the work piece. The clamping force increases proportionally to the surface area defined by the sealing cord.
- **Rotary vacuum pump** with control unit and pressure sensor.
- **Injector pump** with control unit.

Die Ansaugbohrungen werden mit Hilfe von **Triva Clamp-Ventilen** versiegelt. Wenn die Ventile geschlossen sind, sind keine Löcher in der Platte vorhanden, so dass kaum Kühlflüssigkeit eindringen kann. Das **Triva Clamp-Ventil** wird bei der Auflage des Werkstückes automatisch aktiviert. Ständiges manuelles Öffnen und Verschliessen der Bohrungen entfällt somit.

*The suction holes are sealed by the **Triva Clamp valves**. With these valves closed there are no holes in the plate so that hardly any coolant can enter. The **Triva Clamp valve** is automatically activated by placing the work piece on the vacuum plate. Hence constant opening and closing of the suction holes is omitted.*

### Theoretische Haltekraft:

Unter Einbezug eines Sicherheitsfaktors für atmosphärische Druckschwankungen und Leckagen im Vakuumkreislauf rechnen wir mit einem zur Verfügung stehenden Druck von 0,85 bar Vakuum oder 8,5 N/cm<sup>2</sup> (wobei der Druck von der Höhe über Meer abhängig ist).

Diesen Druck bezeichnen wir als theoretisch 100%. Bei 300 cm<sup>2</sup> Spannfläche ergibt sich also eine theoretische Spann-/Haltekraft von 8,5 N/cm<sup>2</sup> x 300 cm<sup>2</sup> = 2550N.

Diese theoretische Haltekraft basiert auf einem vollständigen Hohlraum unter dem Werkstück. Dies ist in der Praxis jedoch nicht möglich, weil das Werkstück abgestützt werden muss.

### Effektive Haltekraft:

Das heisst, je grösser der Hohlraum unter dem Werkstück und je geringer die Auflagefläche für das Werkstück, desto grösser sind die Haltekräfte.

**Die effektive Haltekraft ist folglich abhängig vom Wirkungsgrad des Vakuumspannsystems.**

### Vakuumspannsysteme im Vergleich:

#### Lochplatte

Plate with suction holes

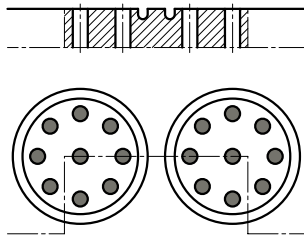

Pro Element Ø 40 mm  
9 Bohrungen Ø 4 mm.  
Each section of Ø 40 mm  
having 9 bores of Ø 4 mm.

Wirkungsgrad: 9%  
Degree of efficiency: 9%

#### Schlitzplatte

Plate with slots

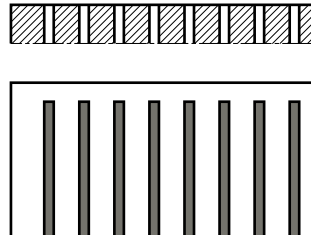

Steg 8 mm, Schlitz 2 mm  
Slots 2 mm, bar 8 mm

Wirkungsgrad: 25%  
Degree of efficiency: 25%

### Theoretical holding force:

Including a safety factor for atmospheric pressure variations and leaks within the vacuum circuit, we calculate an available pressure of 0,85 bar (12,1psi) vacuum equalling 8,5 N/cm<sup>2</sup> (whereas pressure is dependent on altitude).

This amount of pressure is referred to as theoretically attainable 100%. For 300 cm<sup>2</sup> /46,5 sq inch the pressure thus is 8,5 N/cm<sup>2</sup> x 300 cm<sup>2</sup> = 2550N (12,1psi x 46,5sq in = 562lbs).

This theoretically calculated holding force is based upon a hollow space underneath the entire work piece. This is not possible because the work piece must be supported. Therefore we have to subtract the area supporting the workpiece.

### Effective holding force:

In other words: the larger the work piece supporting area, thus reducing the hollow space representing the holding area, the lesser the holding force.

**Consequently, the effective holding force depends entirely upon the rate of efficiency of the vacuum system.**

### Comparison of various vacuum systems:

#### Nutenplatte

Plate with U-shaped grooves

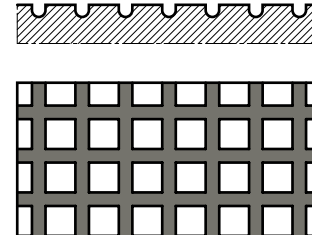

Raster 10x10 mm, Nute 3 mm  
Grid 10x10 mm, grooves 3 mm

Wirkungsgrad: 51%  
Degree of efficiency: 51%

#### Triva Clamp Waffelmuster

Triva Clamp waffle pattern

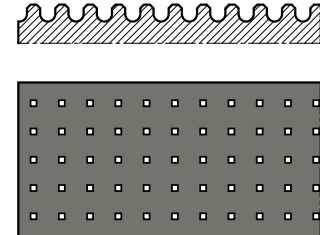

Raster 6,5 mm, Nute 5 mm  
Grid 6,5 mm, grooves 5 mm

Wirkungsgrad: 92%  
Degree of efficiency: 92%

### Besonderheiten von Triva Clamp:

Durch die besondere Formgebung der Werkstückauflage (Waffelmuster) erreicht Triva Clamp einen kaum zu übertreffenden **Wirkungsgrad von theoretisch 92% = 2346 N bei einem maximal erreichbaren Wert von 2550 N (bezogen auf 300 cm<sup>2</sup> Spannfläche).**

### Toleranzen

Höhe 40 mm ± 0,02 / 400 mm  
Ebenheit über alles: ± 0,03 / 400 mm

Alle Vakuumplatten sind aus hochfestem Aluminium hergestellt und für eine lange Lebensdauer **Hartanodisiert** beschichtet. Durch an jeder Seite angebrachte Koppelbohrungen wird es möglich, die Spannfläche nach Bedarf allseitig zu erweitern.

### Special features Triva Clamp:

The unique shape of the Triva Clamp workpiece supporting area (waffle pattern) guarantees maximum attainable holding force with a rate of **efficiency of theoretically 92%, equalling 2346 N holding force applied to the work piece of 300cm<sup>2</sup> (46,5sq in) holding surface.**

### Tolerances

Height 40 mm ± 0,02 / 400 mm  
Flatness all over: ± 0,03 / 400 mm

Vacuum plates are made from high tensile aluminum alloy, are **hard anodized** treated for long tool life. Triva plates can be coupled longitudinally and transversely with any holding plate to suit workpieces, limited by machine table size only.





# Die Spannungsunterschiede zwischen mechanisch und Vakuum

## The differences between mechanical and vacuum

trivaCLAMP

**Mechanische Spannung = Druck auf das Werkstück,** daraus resultieren:

- Belastung des Werkstücks
- Druckmarken in weichen Werkstoffen
- Verformung labiler Teile
- Risiko von Vibrationen

**Mechanical clamping = pressure applied to workpiece,** result:

- Stress applied to workpiece
- Pressure marks in soft materials
- Deforming of delicate workpieces
- Risk of vibrations

**Vakuumspeannung = Druck auf Spannplatte**

Durch die umgebende Atmosphäre, daraus folgt:

- Schonende, gleichmässige Fixierung jeglicher Werkstoffe über die ganze Auflagefläche
- Keine Vibrationen
- Freier Bestückungs- und freier Arbeitsraum

**Vacuum clamping = pressure upon vacuum-plate**

By the surrounding atmosphere, resulting in:

- Equal distribution of holding force over the Entire workpiece holding surface
- Machining with no risk of vibrations
- Free, clear loading and processing area

### Spannen von Platten mit Klemm-Briden

Haltekräft nur am Rand. Vibrationen in Werkstückmitte. Folgeoperationen notwendig.

#### Clamping of plates, using clamps

Edges fixed only - Vibrations in center of workpiece - Subsequent operations required.

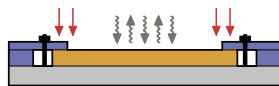

### Spannen von unförmigen Werkstücken

Für Werkstücke mit unförmigen Konturen und Durchgangsbohrungen stellen wir Spezialvorrichtungen her.

#### Holding of bulky workpieces

We build special devices for workpieces with bulky outlines and through bore-holes.

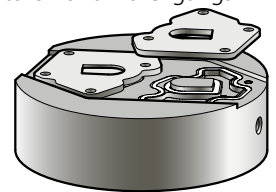

### Spannen von Platten mit Tiefspannbacken

Haltekräft nur am Rand, Vibrationen in Werkstückmitte. Hoher Spanndruck erzeugt Spannung und Verformung.

#### Clamping of plates, using clamping jaws

Also high pressure applied to workpiece, holding effect at the edges - Risk of deformation and vibrations.



### Spannen von Platten auf Vakuum-Platte

Haltekräft gleichmässig über ganze Auflagefläche verteilt. Keine Vibrationen - Freier Arbeitsraum.

#### Holding of plates, using vacuum-plate

Holding force equally spread all over the workpiece holding area - No vibrations - Free processing area.

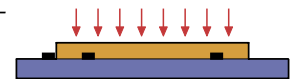

### Kubus spannen im Schraubstock

Belastung des Werkstücks - Risiko von Druckmarken.

#### Clamping of cubic-shaped items, using vise

Stress applied - Risk of pressure marks in workpiece.



### Kubisches Werkstück spannen mit Vakuum-Platte und Steilwänden

Werkstück an 3 (bis 5) Seiten ohne mechanischen Druck gehalten.

#### Holding of cubic-shaped item, using vacuum-plate and vertical walls

Workpiece held from 3 (up to 5) directions. No stress applied - No stress applied - No pressure marks.

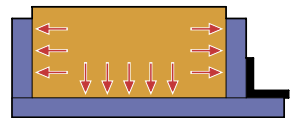

### Spannen von U-Profilen im Schraubstock

Risiko von Deformationen und Vibrationen.

#### Clamping of U-profile, using vise

Risk of deformation and vibrations during processing.

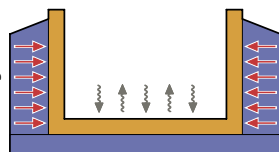

### Spannen von U-Profilen mit Vakuum-Platte und Steilwänden

Allseitig gleichmässige, druckfreie Aufspannung. Bearbeitung ohne Risiko von Vibrationen.

#### Holding of U-profile, using vacuum-plate and 2 vertical walls

Uniform, stressfree holding from 3 directions - No risk of deformations or vibrations during processing.

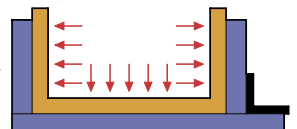

### Spannen von Winkelprofil mit Briden

Umständliches Bestücken und Bearbeiten sowie grosse Vibrationen.

#### Clamping of angled workpiece, using clamps

Bothersome clamps, vibrations, subsequent operation.

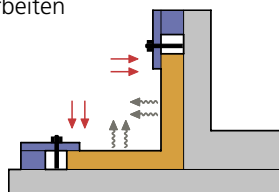

### Spannen von Winkelprofil mit Vakuum-Platte und 1 Steilwand

Gleichmässig verteilte Haltekräft. Leichtes Bestücken und freier Arbeitsraum. Keine Vibrationen, keine Nacharbeit notwendig.

#### Holding of angled workpiece, using vacuum-plate and 1 vertical wall

Uniform stressfree holding - No risk of vibrations - No clamps, free, clear work area for easier, faster loading and processing.

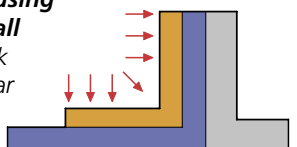

Rote Pfeile → zeigen die Spannrichtung, graue Pfeile ~→ zeigen Vibrationskräfte  
Red arrows → show the holding force direction, gray arrows ~→ show vibration forces

Vakuumplatte auf Maschinentisch befestigen / *Mounting vacuum plate on machine table*

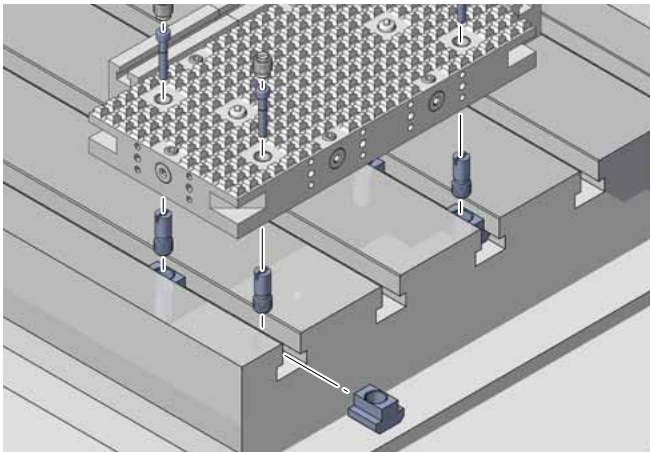

Mechanisch befestigt / *Mechanical mounting*

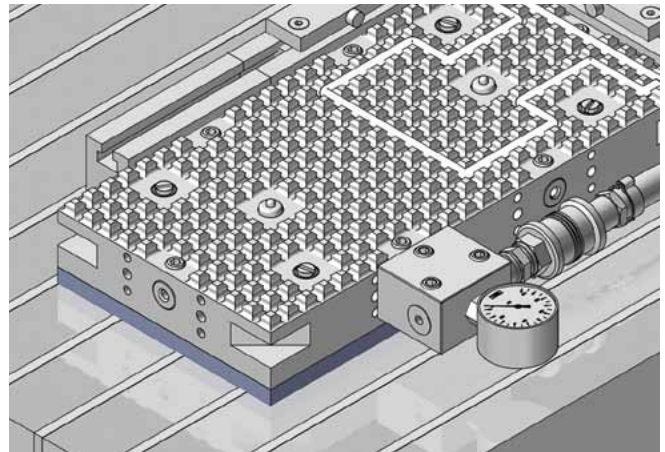

Magnetisch befestigt / *Magnetical mounting*

Platten koppeln / *Connect plates*

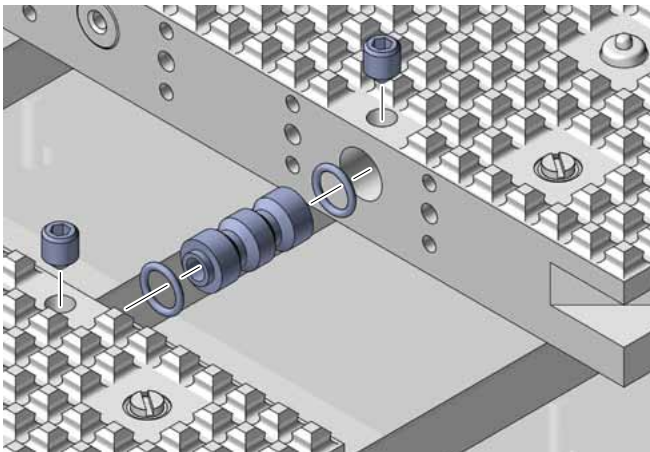

Mit Vakuumverbinder / *With vacuum circuit connector*

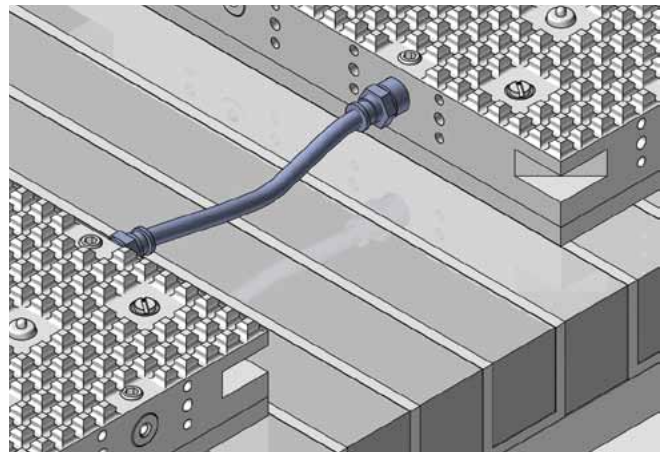

Mit Verbindungsschlauch / *With connector-tube*

Mit Pumpe verbinden / *Connect to pump*

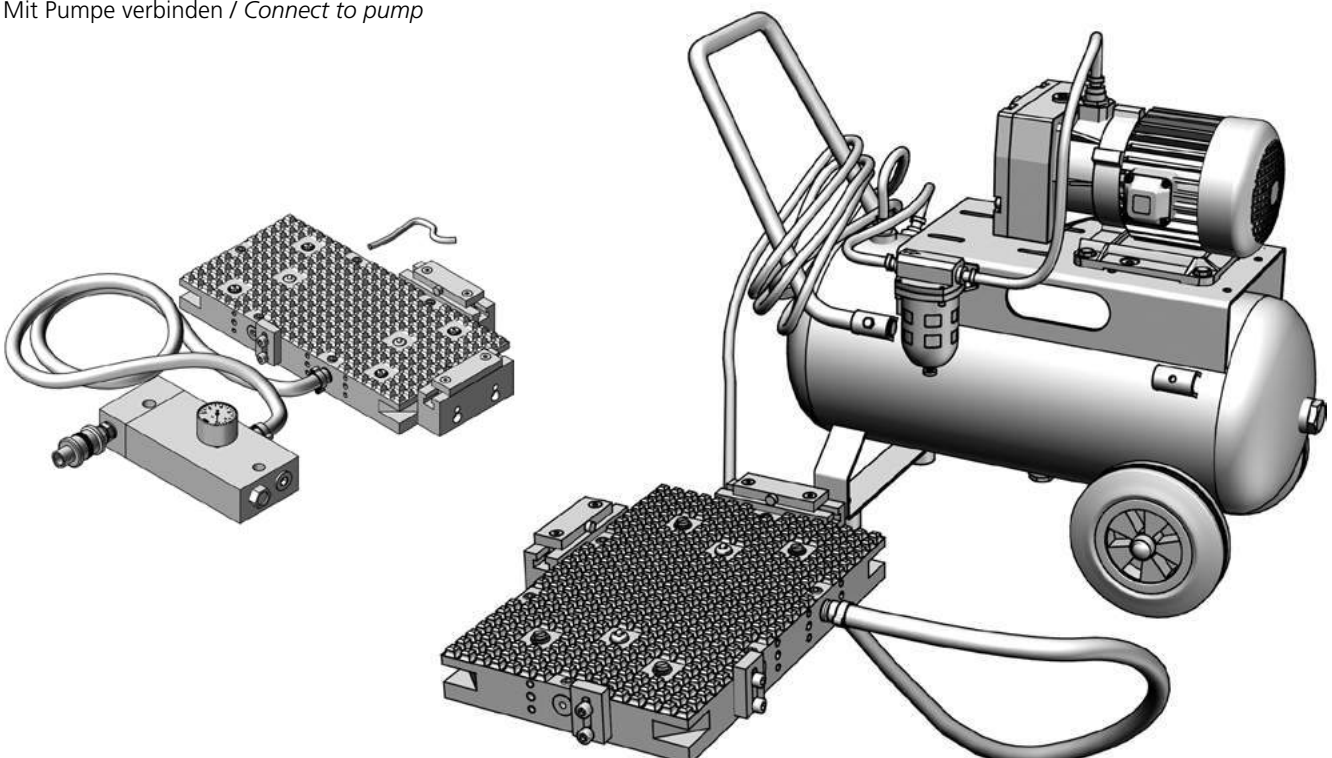



Dichtsnur und Werkstück einlegen / Insert sealing cord and workpiece

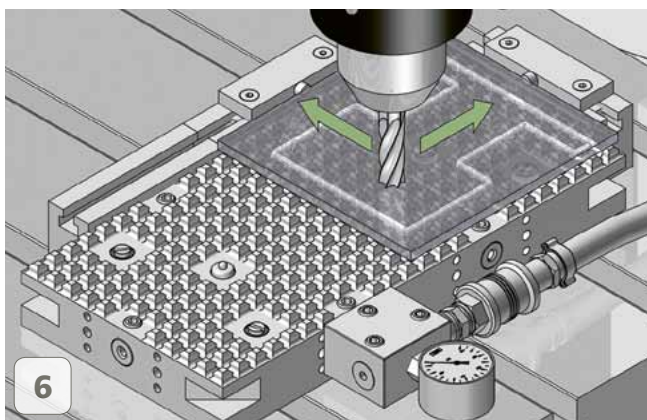
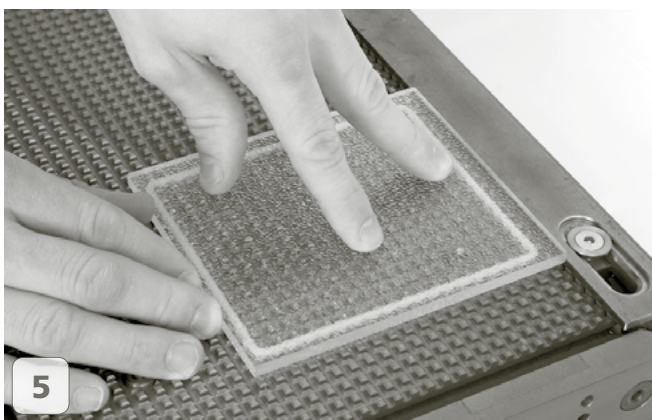
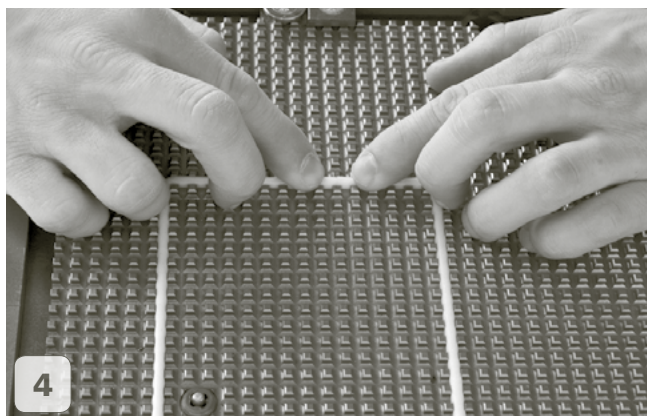
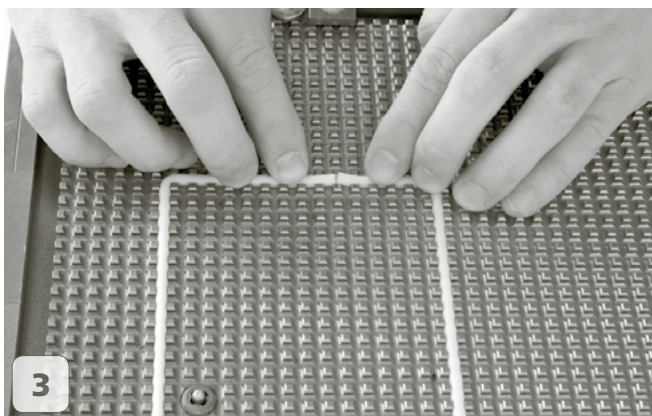
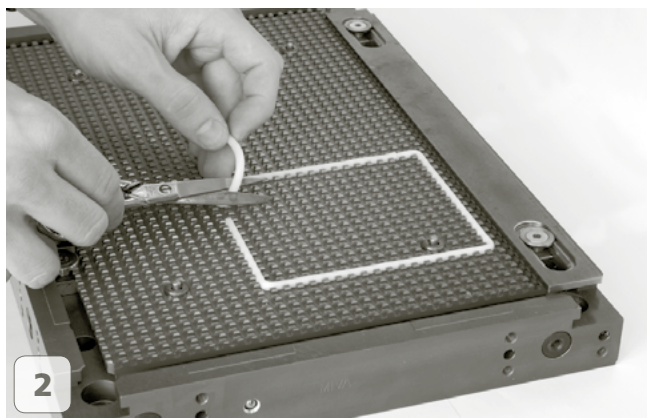
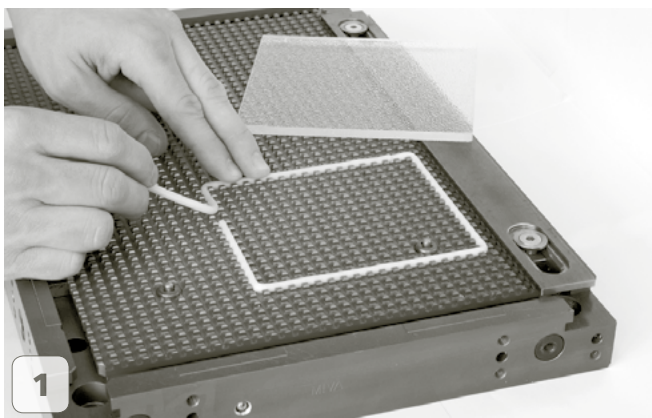

**Fräsrichtung beachten:**  
 wenn möglich, gegen Festanschlüge fräsen.  
**Pay attention to machining direction:**  
 if possible, toward stop gages milling.

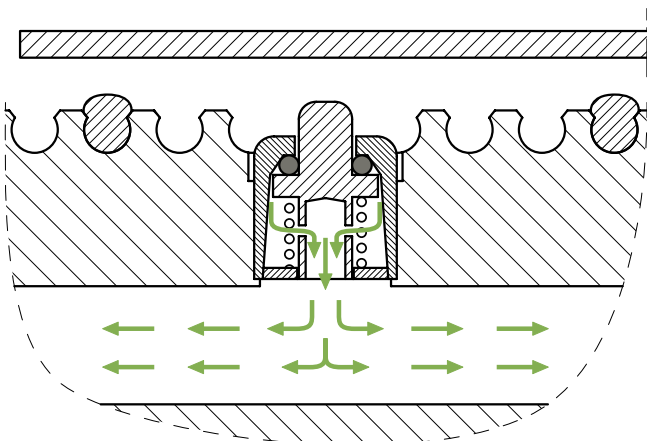

Ventil geschlossen / Valve sealed

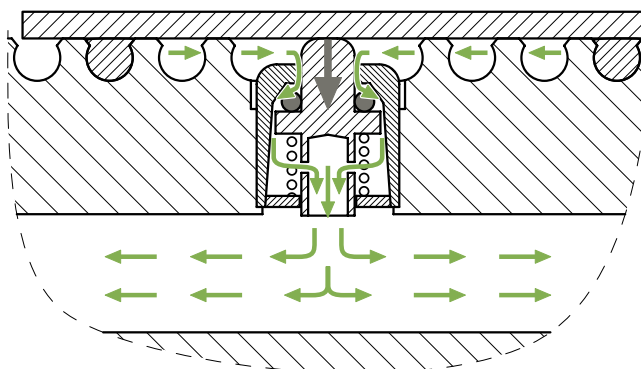

Werkstück eingelegt: Ventil offen  
 Workpiece inserted: Valve open







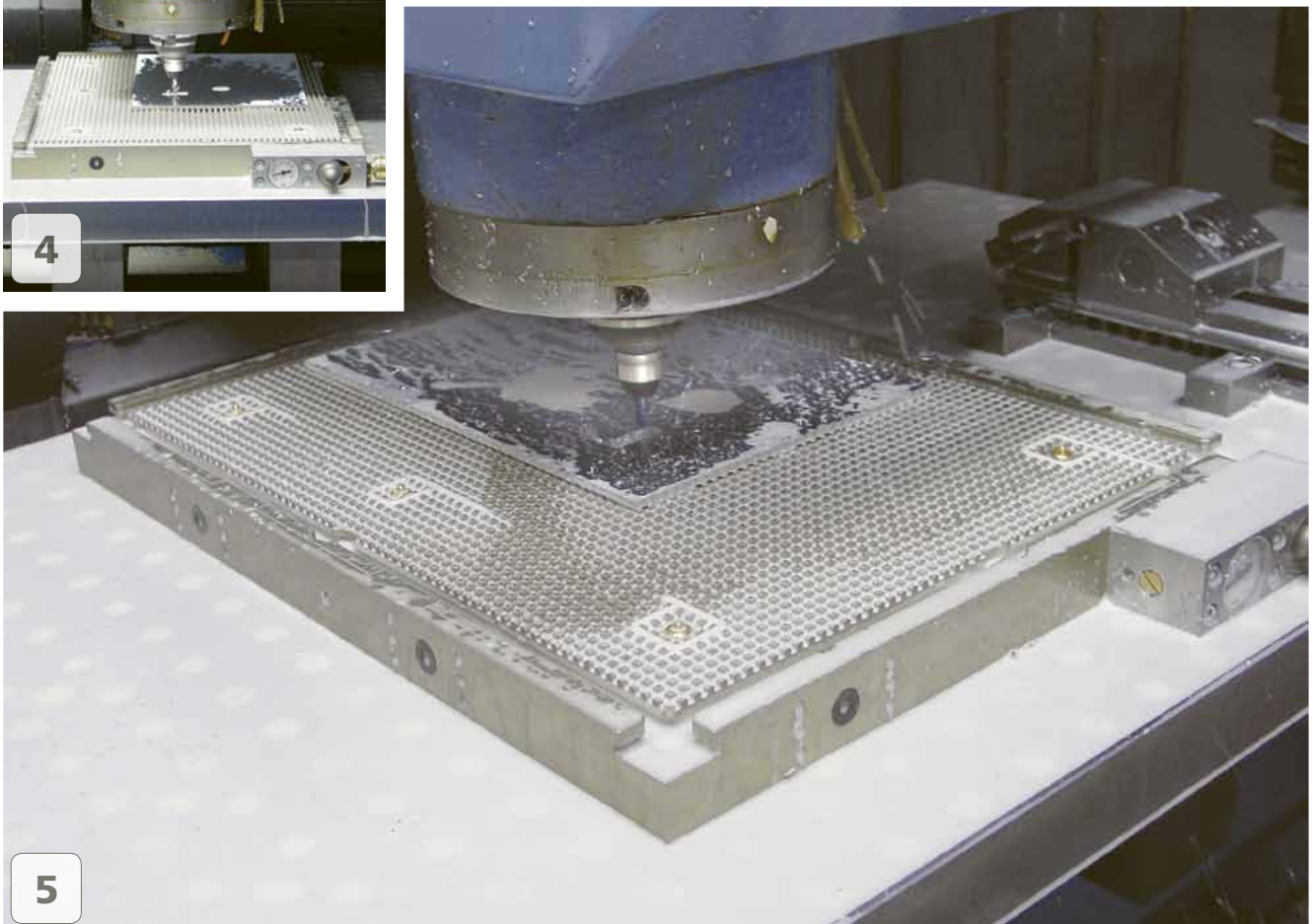
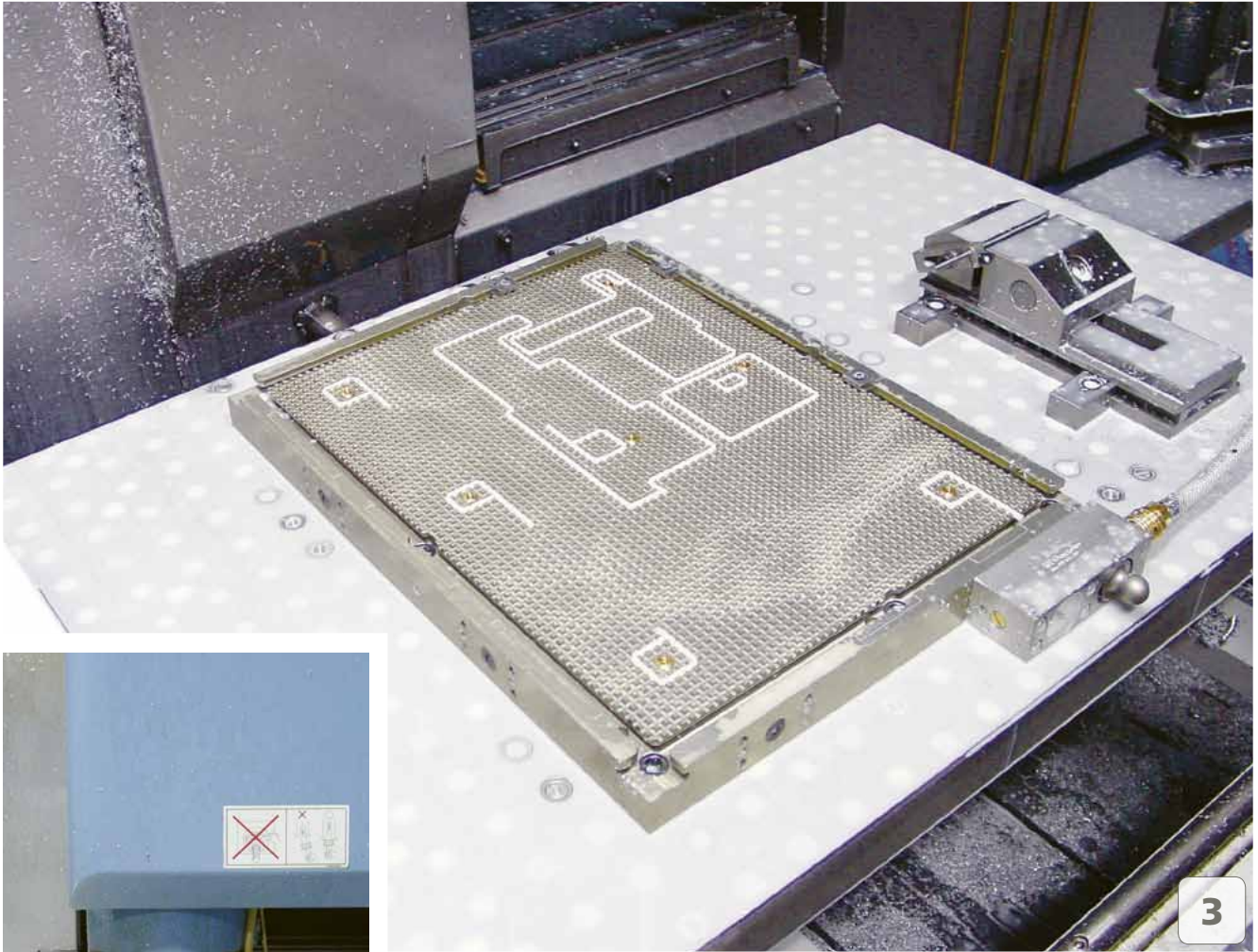



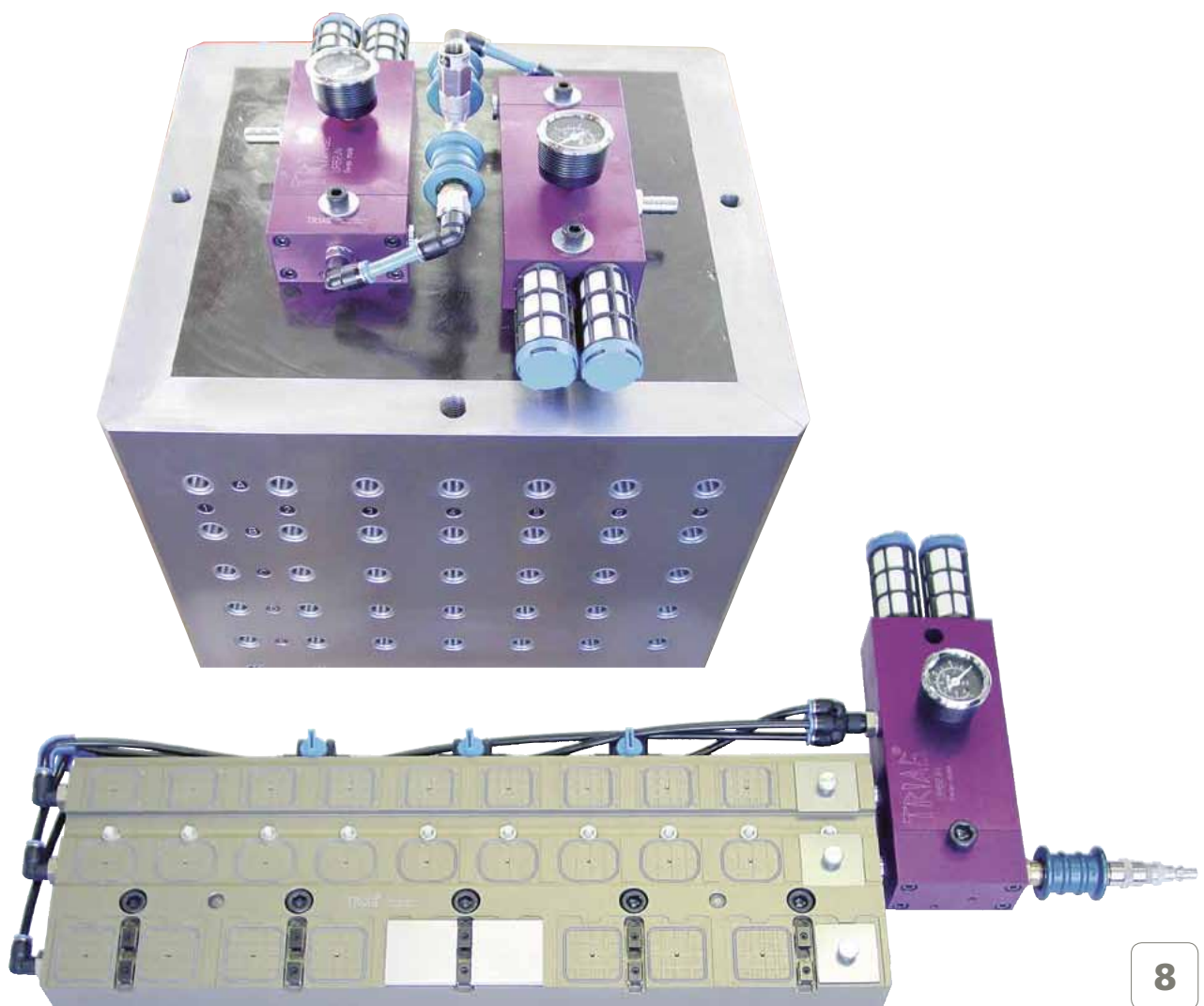



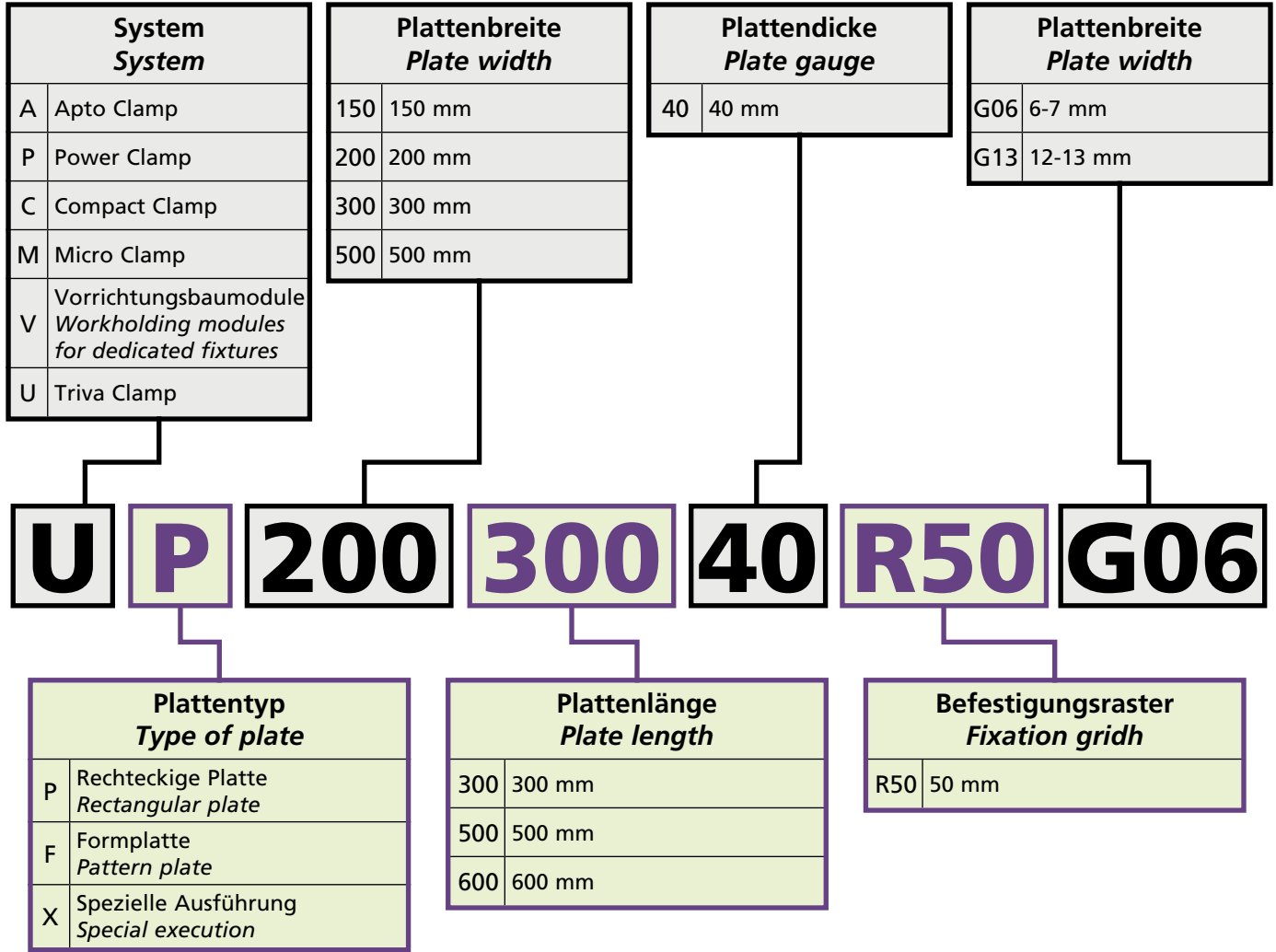







**UF50050050R50...**

**Formplatten**

Für spezielle Werkstücke, die für das Spannen auf den Standardplatten ungeeignet sind, haben wir Rohplatten entwickelt, die bis zu 3 mal überfräst werden können. So lassen sich bis zu 3 verschiedene Werkstücke nacheinander bearbeiten.

**Die plates**

For special work pieces that are unsuitable for clamping on the standard plates, we have developed raw plates that can be milled again up to 3 times. This way, up to 3 different work pieces can be machined one after the other.

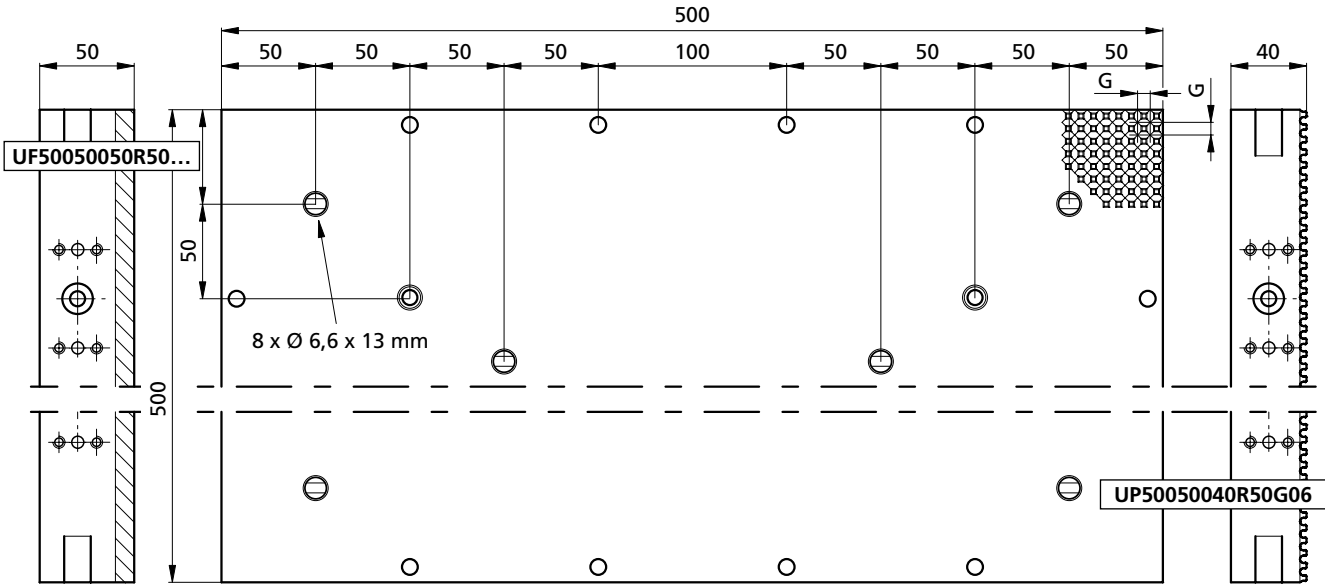

- G13**
- UP50050040R50G13**
- ① 1x TH160150
  - ② 4x 0700100
  - ③ 1x 1110100
  - ④ 15x 0920000
  - ⑤ 16x 1111003
  - ⑥ 16x M10X12ISO4027
  - ⑦ 8x M6X45ISO4762
  - ⑧ 1x 0910001
  - ⑨ 8x 0700102
- G = 12,5 mm  
kg ~24

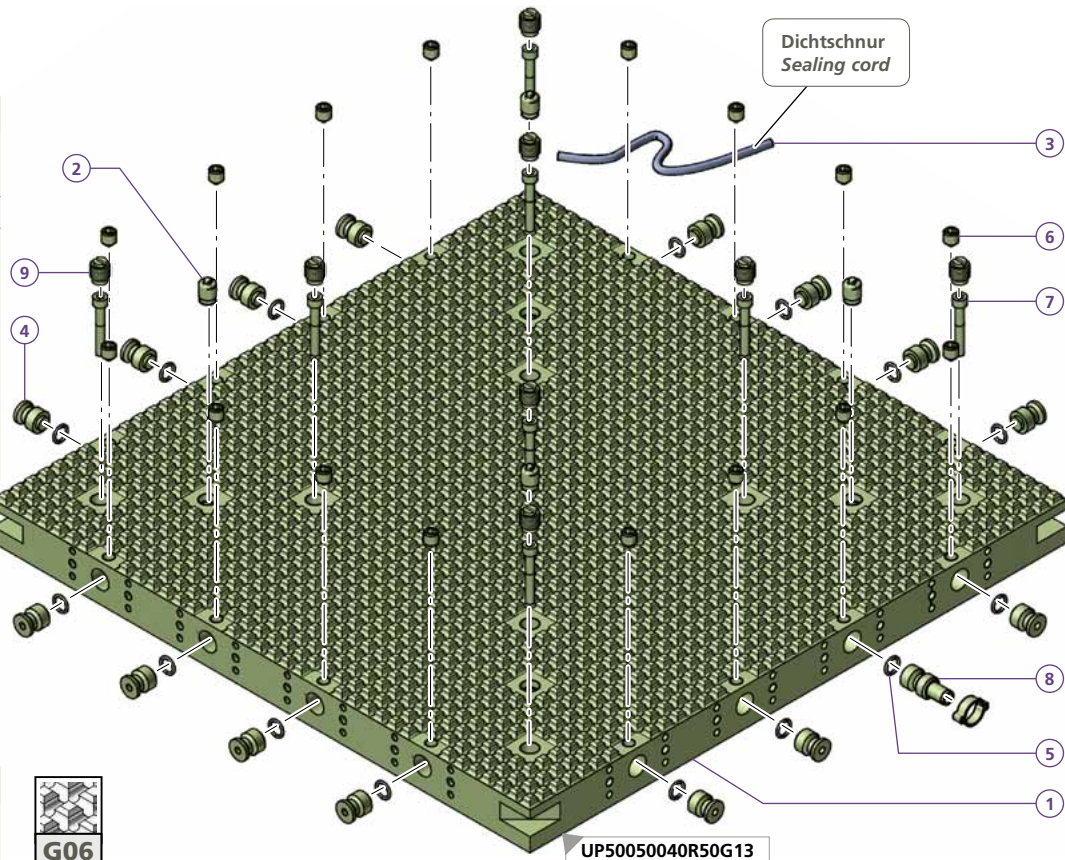

- UF50050050R50...**
- ① 1x TH160151
  - ② 4x 0700100
  - ③ 1x
  - ④ 15x 0920000
  - ⑤ 16x 1111003
  - ⑥ 16x M10X12ISO4027
  - ⑦ 8x M6X45ISO4762
  - ⑧ 1x 0910001
  - ⑨ 8x 0700102
- kg ~32,5

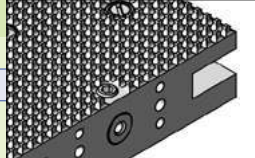
- G06**
- UP50050040R50G06**
- ① 1x TB160159
  - ③ 1x 1120100
- G = 6,5 mm  
kg ~26
- 

**Profilfräser / Carbide end mills G13 / G06 p. 324**  
Dichtschnüre je nach Bedarf / Sealing cords as needed

**Bestellbeispiel / Ordering example:**  
UP50050040R50G13 & 1x 1110100

Separat bestellen / Separate order



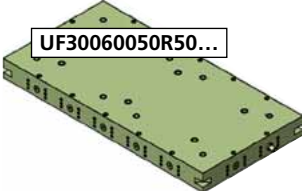

**UF30060050R50...**

**Formplatten**

Für spezielle Werkstücke, die für das Spannen auf den Standardplatten ungeeignet sind, haben wir Rohplatten entwickelt, die bis zu 3 mal überfräst werden können. So lassen sich bis zu 3 verschiedene Werkstücke nacheinander bearbeiten.

**Die plates**

For special work pieces that are unsuitable for clamping on the standard plates, we have developed raw plates that can be milled again up to 3 times. This way, up to 3 different work pieces can be machined one after the other.

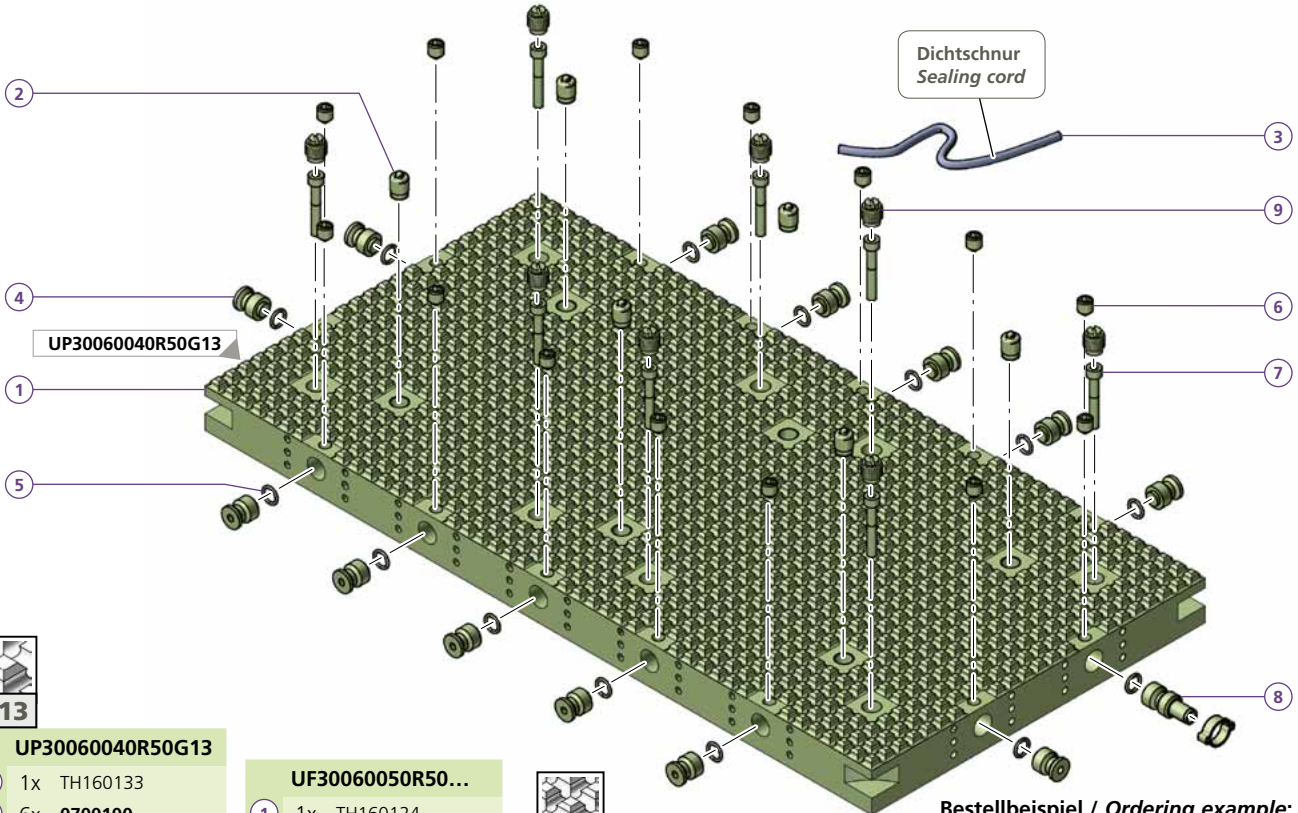
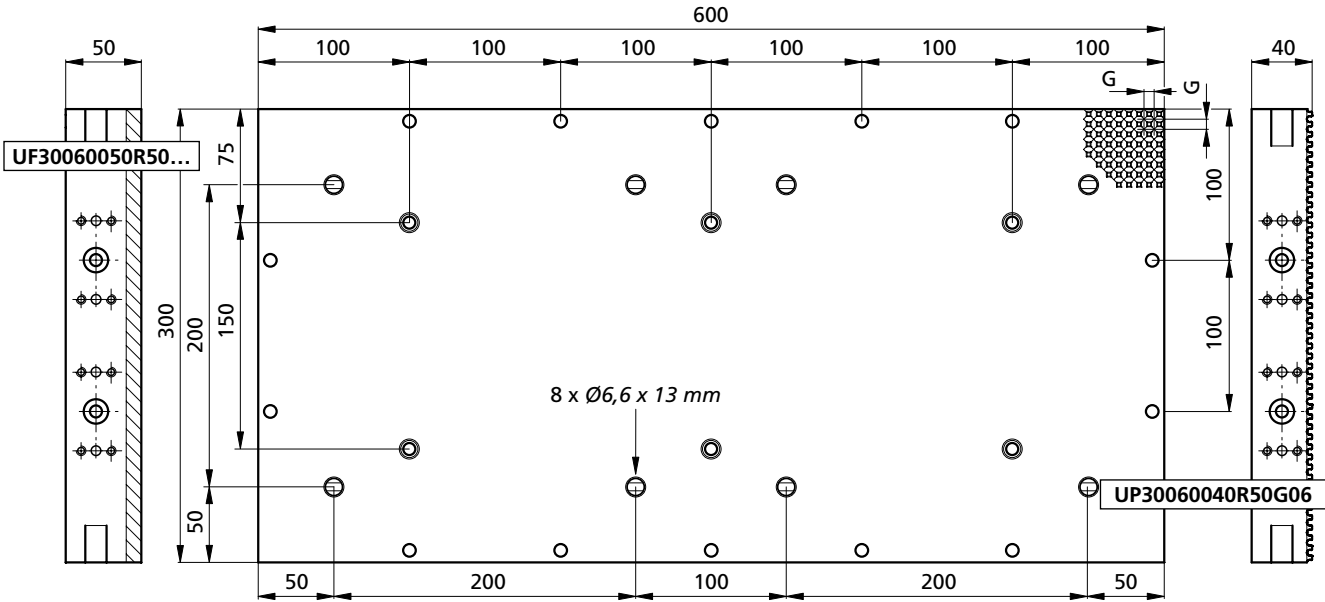

UP30060040R50G13	
1	1x TH160133
2	6x 0700100
3	1x 1110100
4	13x 0920000
5	13x 1111003
6	14x M10X12ISO4027
7	8x M6X45ISO4762
8	1x 0910001
9	8x 0700102
G	= 12,5 mm
kg	~18

UF30060050R50...	
1	1x TH160124
2	6x 0700100
3	1x
4	13x 0920000
5	13x 1111003
6	14x M10X12ISO4027
7	8x M6X45ISO4762
8	1x 0910001
9	8x 0700102
kg	~24,36



UP30060040R50G06	
1	1x TH120176
3	1x 1120100
G	= 6,5 mm
kg	~18,5

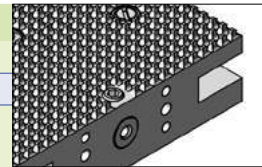

Bestellbeispiel / Ordering example:  
UP30060040R50G13 & 1x 1110100

Profilfräser / Carbide end mills G13 / G06 p. 324  
Dichtsnüre je nach Bedarf / Sealing cords as needed

Separat bestellen / Separate order





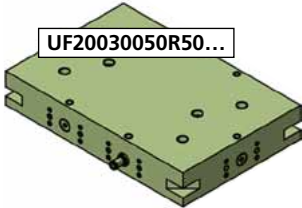

UF20030050R50...

**Formplatten**

Für spezielle Werkstücke, die für das Spannen auf den Standardplatten ungeeignet sind, haben wir Rohplatten entwickelt, die bis zu 3 mal überfräst werden können. So lassen sich bis zu 3 verschiedene Werkstücke nacheinander bearbeiten.

**Die plates**

For special work pieces that are unsuitable for clamping on the standard plates, we have developed raw plates that can be milled again up to 3 times. This way, up to 3 different work pieces can be machined one after the other.

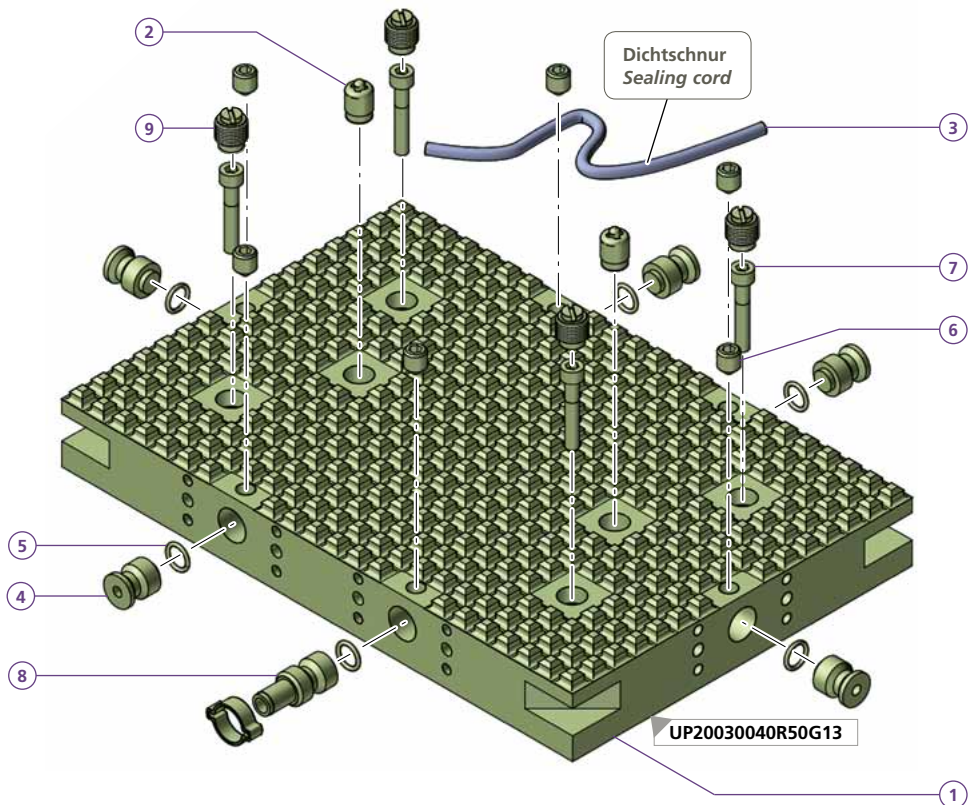
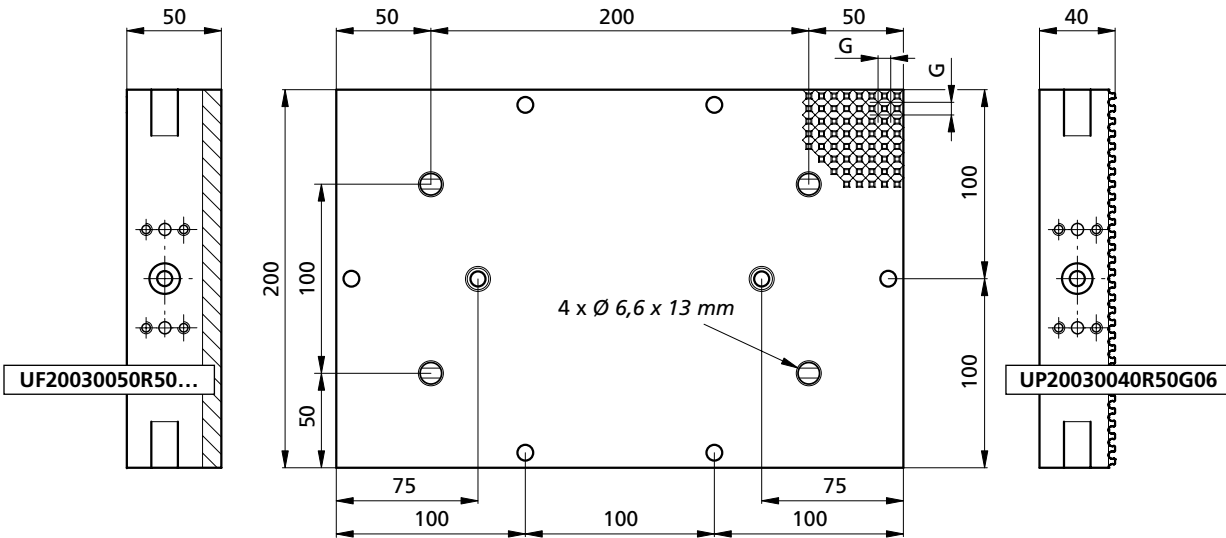

UP20030040R50G13	
1	1x TH160135
2	2x 0700100
3	1x 1110100
4	5x 0920000
5	6x 1111003
6	6x M10X12ISO4027
7	4x M6X45ISO4762
8	1x 0910001
9	4x 0700102
G	= 12,5 mm
kg	~5,5



UP20030040R50G06	
1	1x TH120175
3	1x 1120100
G	= 6,5 mm
kg	~6,0

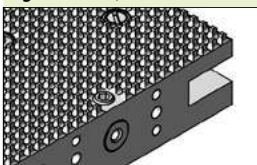

UF20030050R50...	
1	1x TH160136
2	2x 0700100
3	1x
4	5x 0920000
5	6x 1111003
6	6x M10X12ISO4027
7	4x M6X45ISO4762
8	1x 0910001
9	4x 0700102
kg	~8,09

Bestellbeispiel / Ordering example:  
UP20030040R50G13 & 1x 1110100

Profilfräser / Carbide end mills G13 / G06 p. 324

Dichtschnüre je nach Bedarf / Sealing cords as needed





**UF15030050R50...**

**Formplatten**

Für spezielle Werkstücke, die für das Spannen auf den Standardplatten ungeeignet sind, haben wir Rohplatten entwickelt, die bis zu 3 mal überfräst werden können. So lassen sich bis zu 3 verschiedene Werkstücke nacheinander bearbeiten.

**Die plates**

For special work pieces that are unsuitable for clamping on the standard plates, we have developed raw plates that can be milled again up to 3 times. This way, up to 3 different work pieces can be machined one after the other.

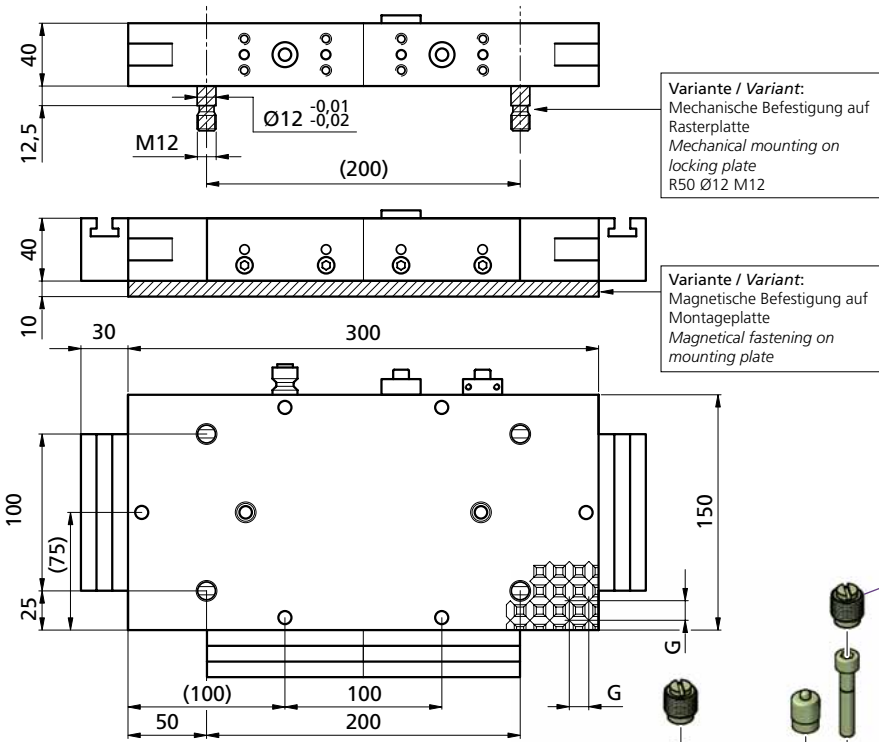

**G13**

**UP15030040R50G13**

1	1x TH150942
2	2x 0700100
3	1x 1110100
4	5x 0920000
5	6x 1111003
6	6x M10X12ISO4027
7	4x M6X35ISO4762
8	1x 0910001
9	4x 0700102
10	4x ADAPT6-12

G = 12,5 mm  
kg ~4,6

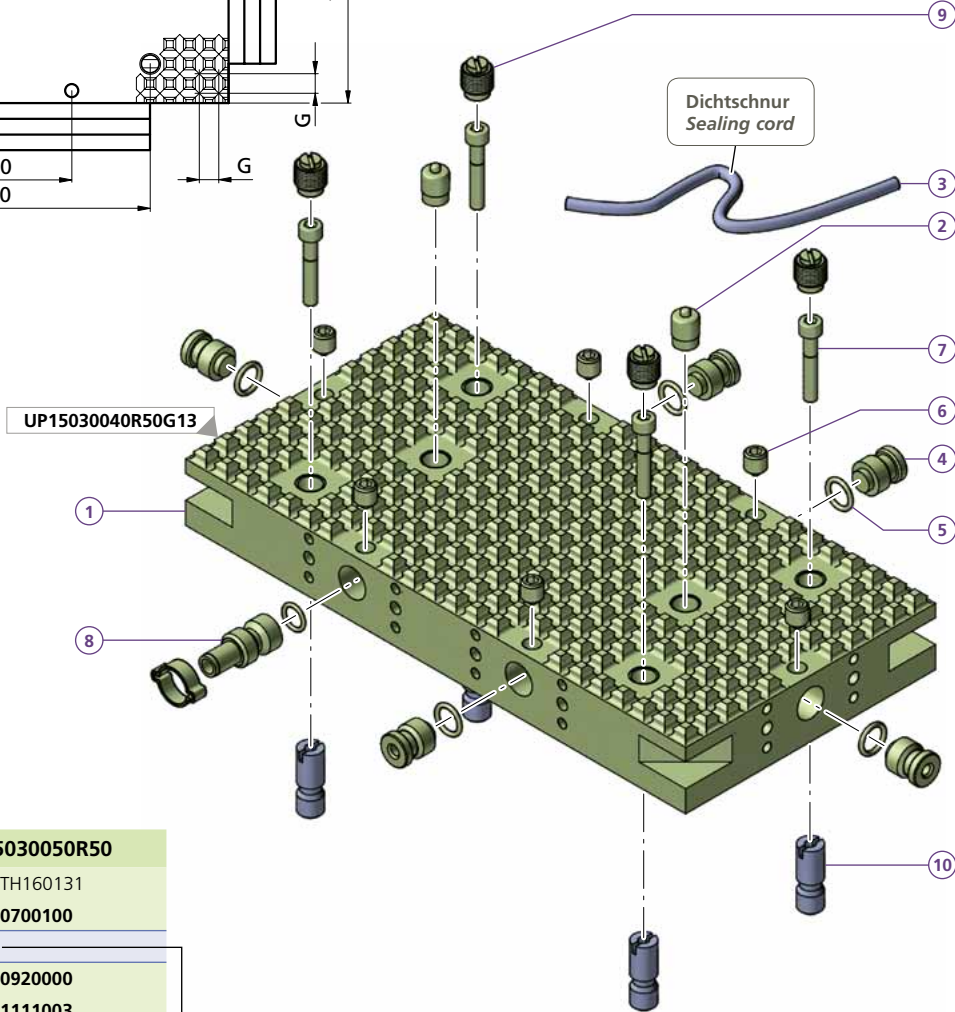

**G06**

**UP15030040R50G06**

1	1x TH160132
3	1x 1120100

G = 6,5 mm  
kg ~4,8

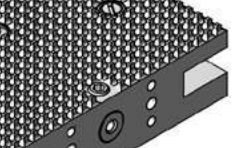

**UF15030050R50**

1	1x TH160131
2	2x 0700100
3	1x
4	5x 0920000
5	6x 1111003
6	6x M10X12ISO4027
7	4x M6X35ISO4762
8	1x 0910001
9	4x 0700102

kg ~6

Bestellbeispiel / Ordering example:  
UP15030040R50G13 & 1x ADAPT6-12 & 1x 1110100

Profilfräser / Carbide end mills G13 / G06 p. 324  
Dichtschnüre je nach Bedarf / Sealing cords as needed

Separat bestellen / Separate order

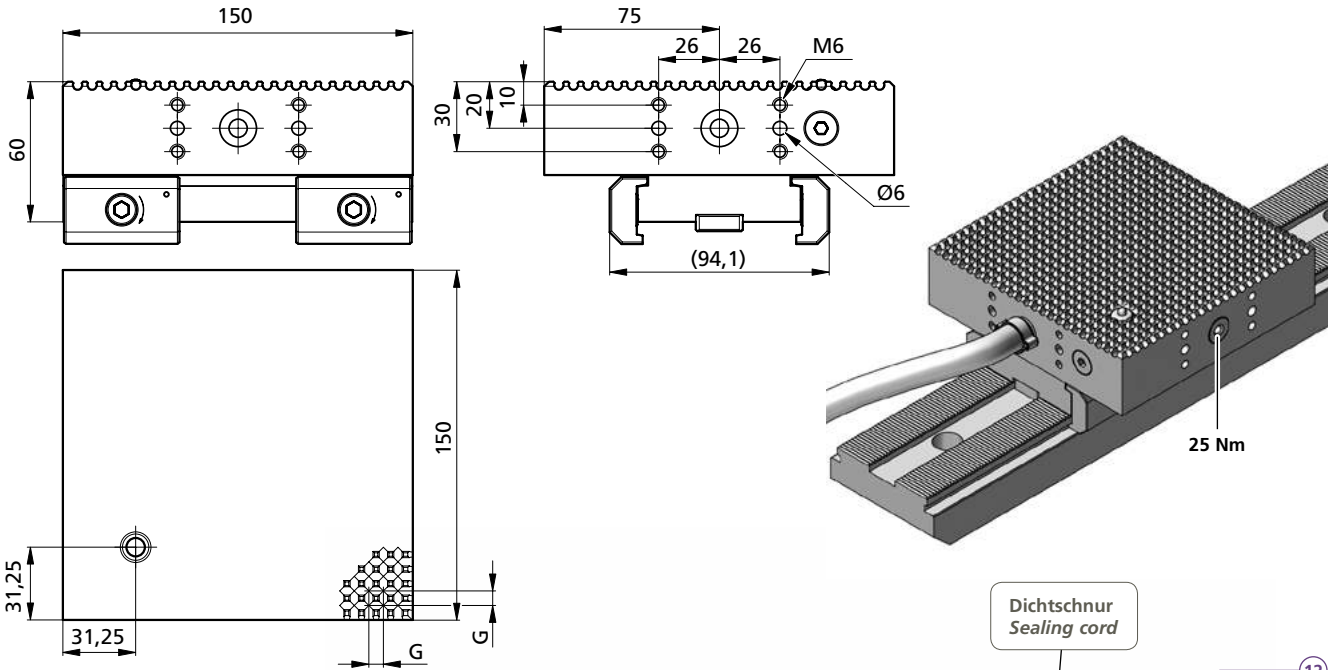

Dichtschnur  
Sealing cord



PS1X150L60-VAC

1	1x TW090017-01	
2	1x 0700100	
3	3x 0920000	
4	4x M10X12ISO4027	
5	1x 0910001	
6	5x 1111003	
7	2x PCSP50R	
8	2x PCSP50L	
9	2x PCS14	
10	2x PCGU2049	
11	2x M6X8ISO7380	
12	1x 1120100	p. 324
13	1x UA182540	p. 322
14	1x UT1003040	
G	= 6,5 mm	
kg	~3,6	

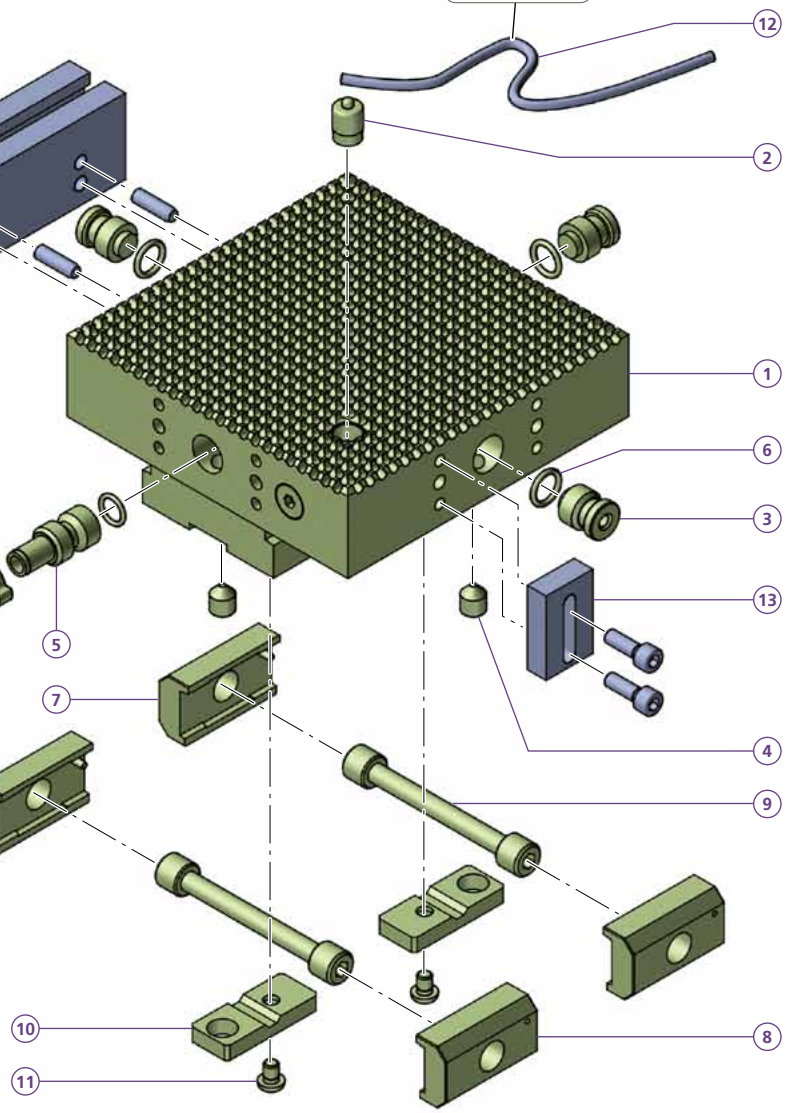

Separat bestellen / Separate order

Bestellbeispiel / Ordering example:  
 PS1X150L60-VAC & 1x 1120100 & 1x UA182540 & 1x UT1003040



# Vakuum-Modul für powerCLAMP Vacuum module for powerCLAMP



PS1X80L31-VAC

trivaCLAMP

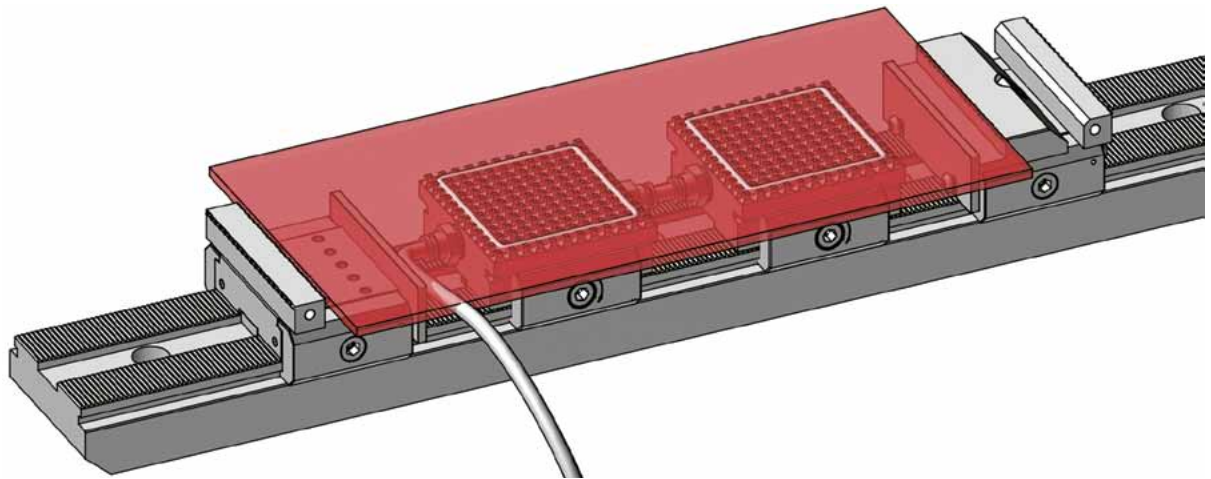
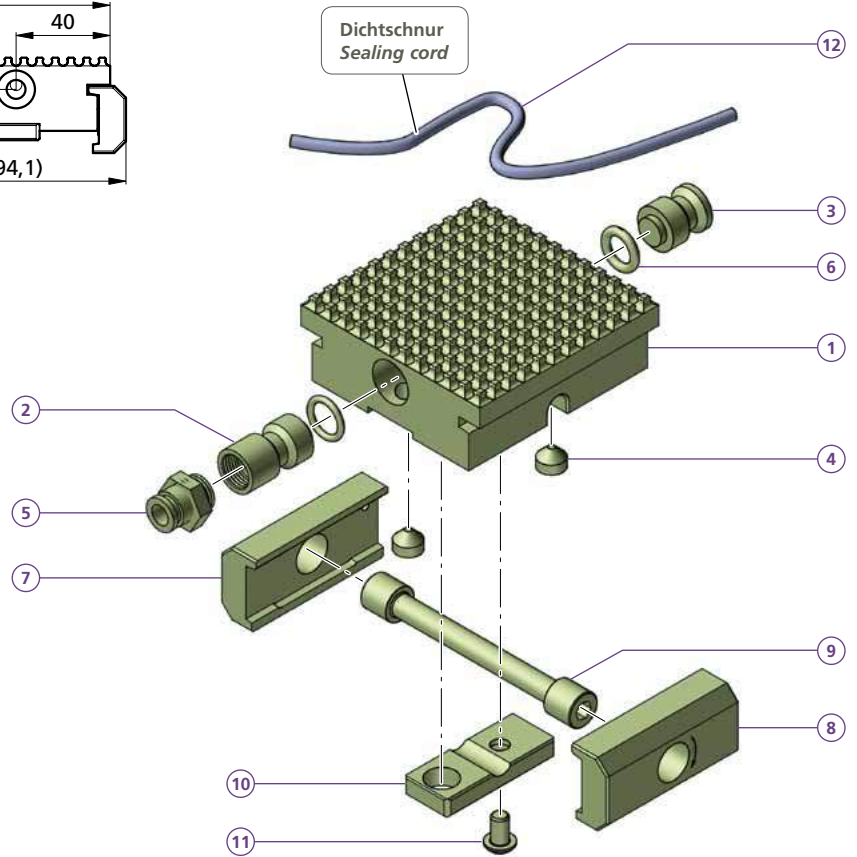
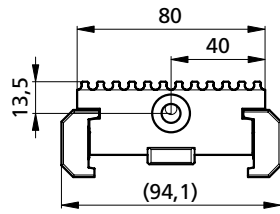
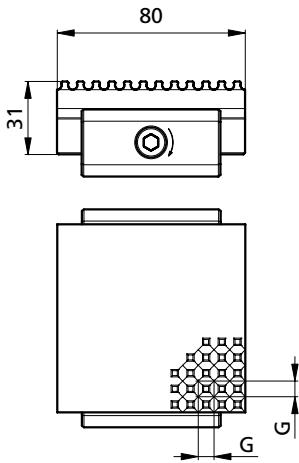

## PS1X80L31-VAC

- ① 1x TH140263
- ② 1x UZV16301/4
- ③ 1x 0920000
- ④ 2x M10X8DIN914
- ⑤ 1x QSG1/4-8
- ⑥ 2x 1111003
- ⑦ 1x PCSP60R
- ⑧ 1x PCSP60L
- ⑨ 1x PCS14
- ⑩ 1x PCGU2049
- ⑪ 1x M6X8ISO7380
- ⑫ 1x 1120100

G = 6,5 mm  
kg ~0,62

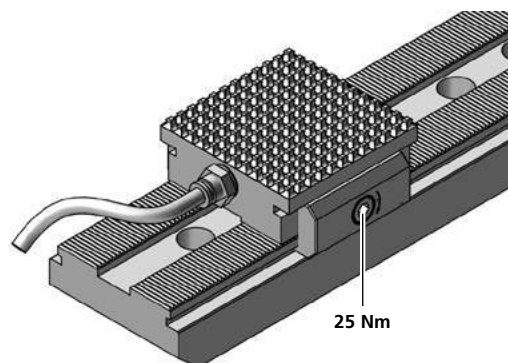

Bestellbeispiel / Ordering example: PS1X80L31-VAC & 1x 1120100

Separat bestellen / Separate order



### UP15030040R50 G06 / G13

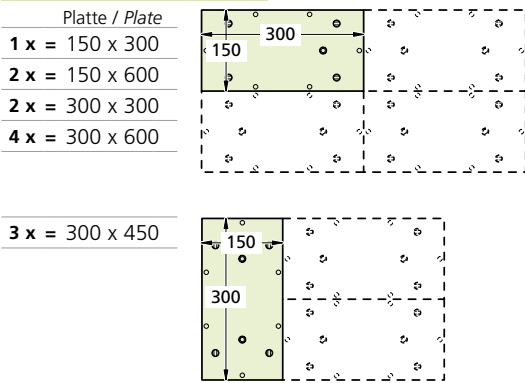

### UP20030040R50 G06 / G13

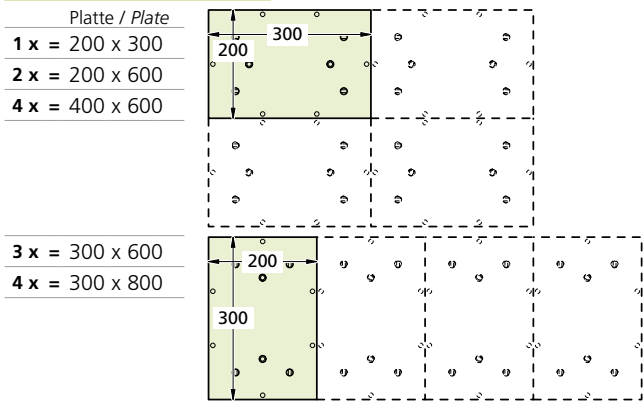

### UP30060040R50 G06 / G13

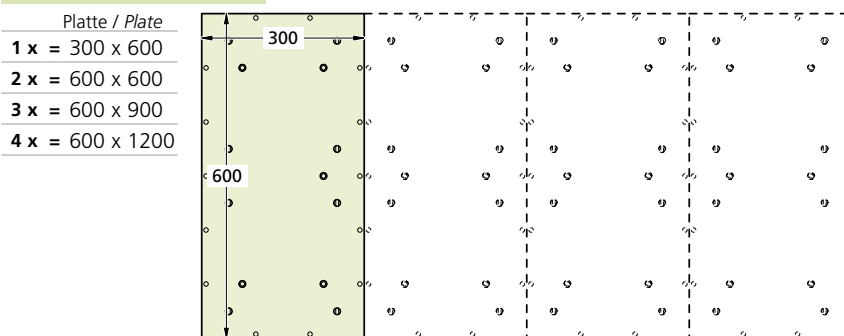

### UP30060040R50 G06 / G13

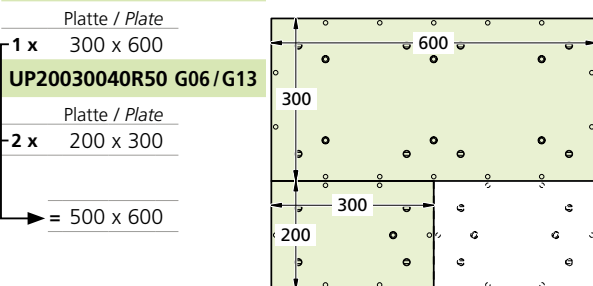

### UP30060040R50 G06 / G13

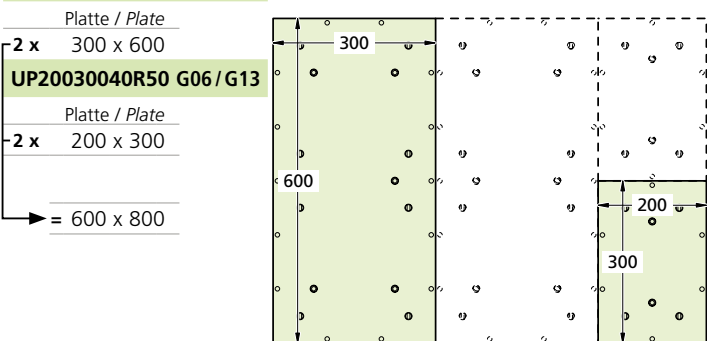

### UP50050040R50 G06 / G13

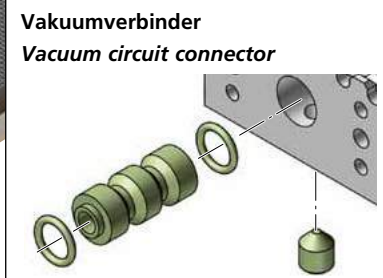
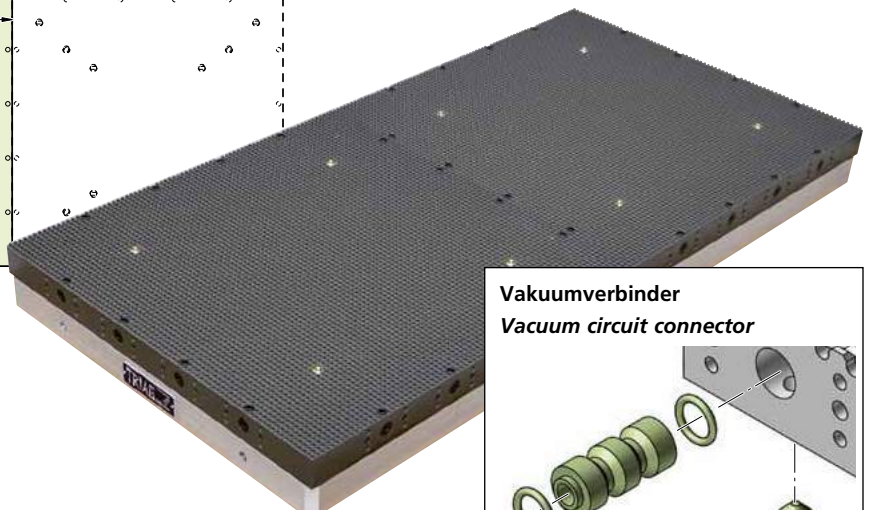
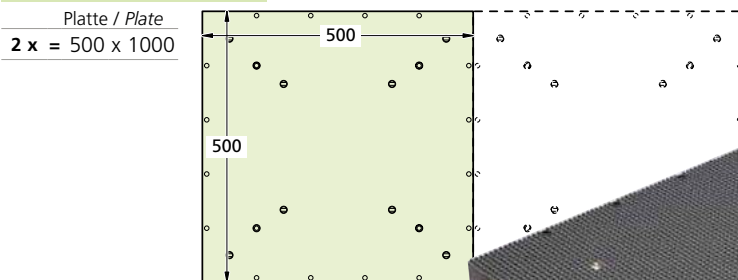

UPSET	D	1	V	G...
<p><b>A</b> UP50050040R50G13 500 500 UF50050050R50 <b>G</b></p> <p><b>B</b> UP30060040R50G13 300 600 UF30060050R50 <b>H</b></p> <p><b>C</b> UP20030040R50G13 200 300 UF20030050R50 <b>I</b></p> <p><b>D</b> UP15030040R50G13 150 300 UF15030050R50 <b>J</b></p> <p><b>E</b> PS1X150L60-VAC <b>G06</b></p> <p><b>F</b> PS1X80L31-VAC <b>G06</b></p>	<p><b>1</b> UPB1JN <b>1</b></p> <p><b>2</b> UPB2JN <b>2</b></p> <p><b>3-5</b> UBA ... <b>3-5</b></p>	<p><b>V</b> UA3-660</p> <p>UT1003040 <b>V</b></p> <p>UA0770</p> <p>UZA5015G13</p> <p>UZA4012G06</p> <p>UA182540</p>		
<p><b>G13</b> <b>G06</b> <b>Vakuumpalte</b> <b>Vacuum plate</b></p>	<p><b>Vakuum erzeugen</b> <b>Generate vacuum</b></p>	<p><b>Zubehör</b> <b>Accessories</b></p>		
<p><b>A</b> 500 x 500 (UP50050040R50 G06 / G13)</p> <p><b>B</b> 300 x 600 (UP30060040R50 G06 / G13)</p> <p><b>C</b> 200 x 300 (UP20030040R50 G06 / G13)</p> <p><b>D</b> 150 x 300 (UP15030040R50 G06 / G13)</p> <p><b>E</b> 150 x 60 (PS1X150L60-VAC)</p> <p><b>F</b> 80 x 31 (PS1X80L31-VAC)</p> <p><b>G</b> 500 X 500 (UF50050050R50)</p> <p><b>H</b> 300 X 600 (UF30060050R50)</p> <p><b>I</b> 200 X 300 (UF20030050R50)</p> <p><b>J</b> 150 X 300 (UF15030050R50)</p>	<p><b>1</b> UPB1JN</p> <p><b>2</b> UPB2JN</p> <p><b>3</b> UBA106230300</p> <p><b>4</b> UBA106110250</p> <p><b>5</b> UBA318400550</p>	<p><b>Z</b> 2x UT1003040 1x UA182540 1x UA3-660</p> <p><b>Y</b> 2x UT1003040 1x UA182540 1x UA3-560</p> <p><b>X</b> 2x UT1003040 1x UA182540 1x UA3-360</p> <p><b>W</b> 2x UT1003040 1x UA182540 1x UA2-260</p> <p><b>V</b> 2x UT1003040 1x UA182540 2x UA0770</p> <p><b>U</b> 4x UZA4012G06</p> <p><b>T</b> 4x UZA5015G13</p>		
<p>Zu jedem SET werden zusätzlich 3 m Vakuumschlauch (0941000) und 25 m Dichtschnur mitgeliefert (1120100) Ø 4 oder (1110100) 6 mm (fest verschraubt) Each SET is supplied with an additional 3 m vacuum hose (0941000) and 25 m sealing cord (1120100) Ø 4 or (1110100) 6 mm (firmly screwed)</p>			<p>Vakuumschlauch Vacuum hose 3 m: 0941000</p> <p>Dichtschnur Sealing cord 25 m: 1120100</p>	
<p>Bestellbeispiel / Ordering example: <b>UPSETD1VG13</b></p>				



Anschlagleisten  
Stop rails

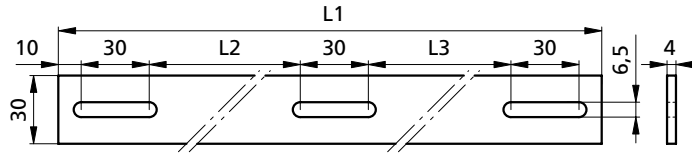

UA3-660	
1	1x TH160274
2	3x M6X12ISO4762
3	3x 6,4 DIN9021
4	3x SM1135M6X8
L1	= 660 mm
L2	= 270 mm
L3	= 280 mm
kg	~0,6

UA3-560	
1	1x TH160275
2	3x M6X12ISO4762
3	3x 6,4 DIN9021
4	3x SM1135M6X8
L1	= 560 mm
L2	= 225 mm
L3	= 225 mm
kg	~0,5

UA3-360	
1	1x TH160277
2	3x M6X12ISO4762
3	3x 6,4 DIN9021
4	3x SM1135M6X8
L1	= 360 mm
L2	= 120 mm
L3	= 130 mm
kg	~0,32

UA2-260	
1	1x TH160278
2	2x M6X12ISO4762
3	2x 6,4 DIN9021
4	2x SM1135M6X8
L1	= 260 mm
L2	= 180 mm
kg	~0,2

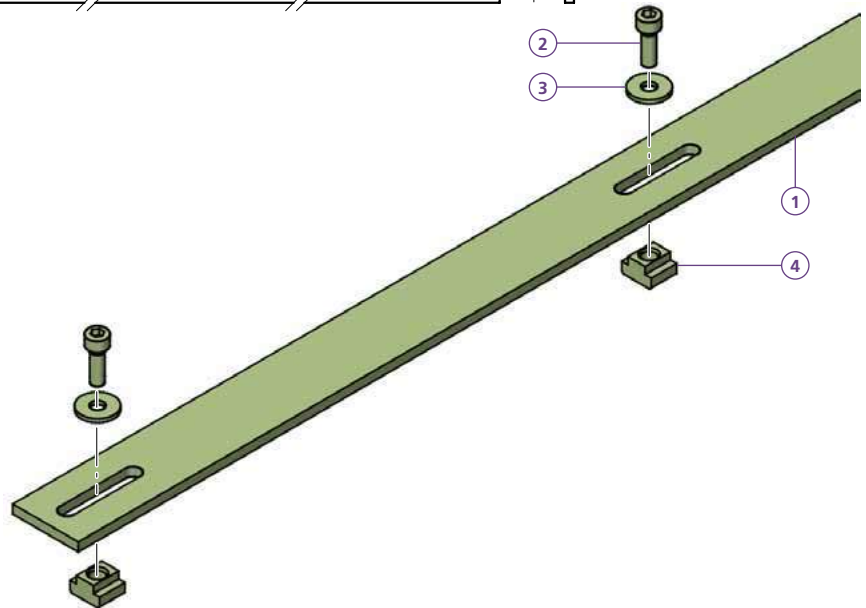

Anschlag  
Stop rail

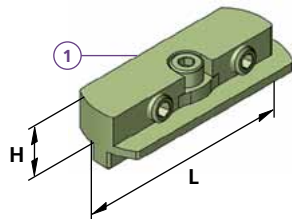

UZA5015G13	
1	1x TB170561
L	= 50 mm
H	= 9 mm
kg	~0,04

Bedienungsanleitung zu diesen zwei Anschlägen  
Operating instructions for these two stops

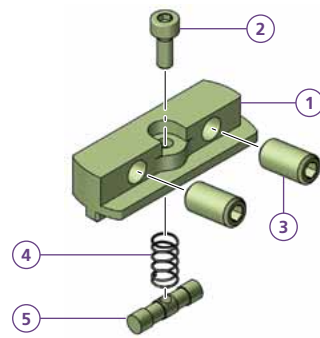

UZA4012G06	
1	1x TB170558
2	1x M4X10ISO4762
3	2x M6X16 DIN913
4	1x TN100535
5	1x TB170562
L	= 40 mm
H	= 8,5 mm
kg	~0,03

T-Nuten Stein  
T-nuts

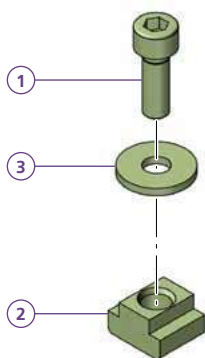

0802000-SET	
1	1x M6X12ISO4762
2	1x SM1135M6X8
3	1x 6,4 DIN9021
kg	~0,03

Ansetzbare T-Nuten  
Attachable T-slots

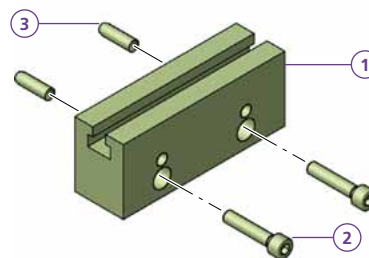

UT1003040	
1	1x TH160227
2	2x M6X25ISO4762
3	2x 6X20-B ISO8734
kg	~0,4

Seiten-/Wendeanschlag  
Reversible stop gage

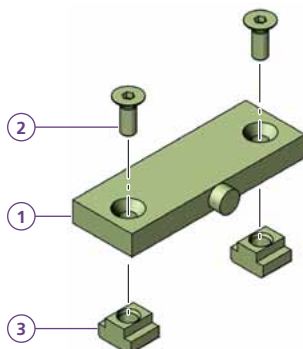

UA0770	
1	1x TH160259
2	2x TN100899
3	2x SM1135M6X8
kg	~0,14

Seitenanschlag  
Side lay

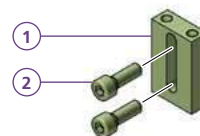

UA182540	
1	1x TH160098
2	2x M6X18ISO4762
kg	~0,1



Vakuumverbinder  
Vacuum circuit connector

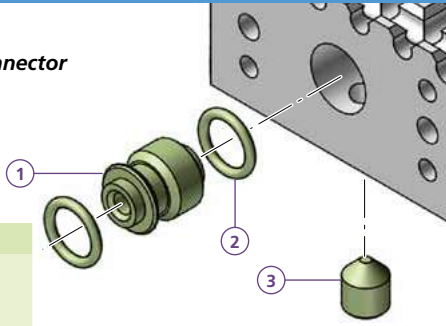

- 0930000**
- ① 1x TK110401
  - ② 2x 1111003
  - ③ 1x M10X12ISO4027
- kg ~0,02

Blindstopfen  
Blind plug

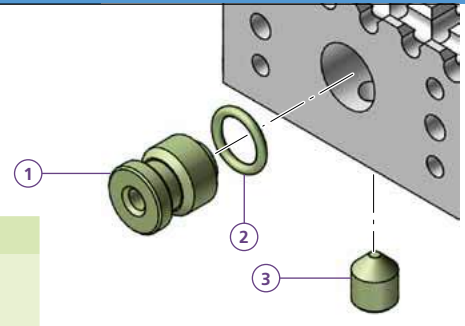

- 0920000**
- ① 1x TK110402
  - ② 1x 1111003
  - ③ 1x M10X12ISO4027
- kg ~0,03

Koppelement  
Link-up plug

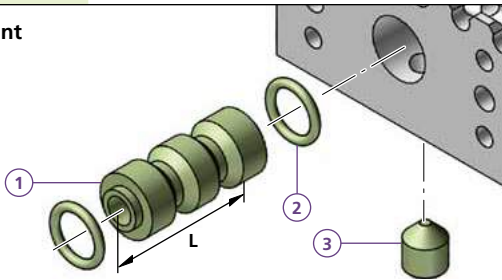

- 0910000**
- ① 1x TK110403
  - ② 2x 1111003
  - ③ 1x M10X12ISO4027
- L = 40 mm
- kg ~0,03

- 0910080**
- ① 1x TK140763
  - ② 2x 1111003
  - ③ 1x M10X12ISO4027
- L = 80 mm
- kg ~0,04

Vakuumverbinder  
Vacuum circuit connector

- TS150487**
- ① 1x TS150487
  - ② 2x TN100682
- d = 5,8 mm
- D = 15 mm

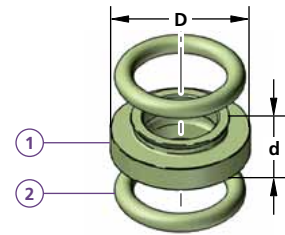

Anschlusselement  
Adapter element

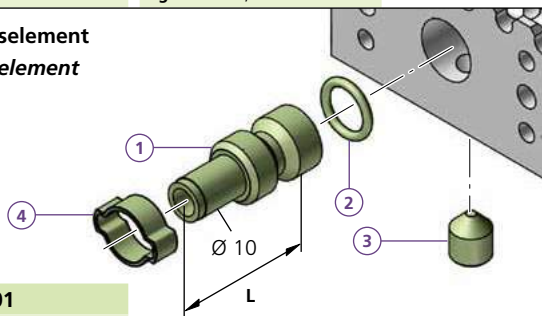

- 0910001**
- ① 1x TK110404
  - ② 1x 1111003
  - ③ 1x M10X12ISO4027
  - ④ 1x TN100992
- L = 40 mm
- kg ~0,04

Vakuumschlauch (per Laufmeter)  
Vacuum hose (per running meter)

- D = 8 mm für Vakuumanbindung von Platte zu Platte  
for vacuum supply from plates to accessories
- D = 16 mm für Vakuumverbindung von Pumpe zu Platten  
for vacuum supply from pump to plate

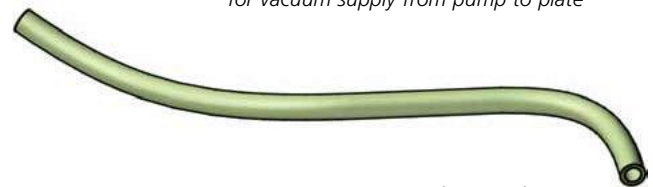

- |                |                |
|----------------|----------------|
| <b>0940800</b> | <b>0941000</b> |
| D = 8 mm       | D = 16 mm      |
| d = 5,5 mm     | d = 10 mm      |

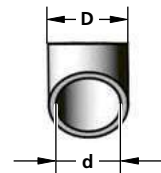

Vakuumverbinder  
Vacuum circuit connector

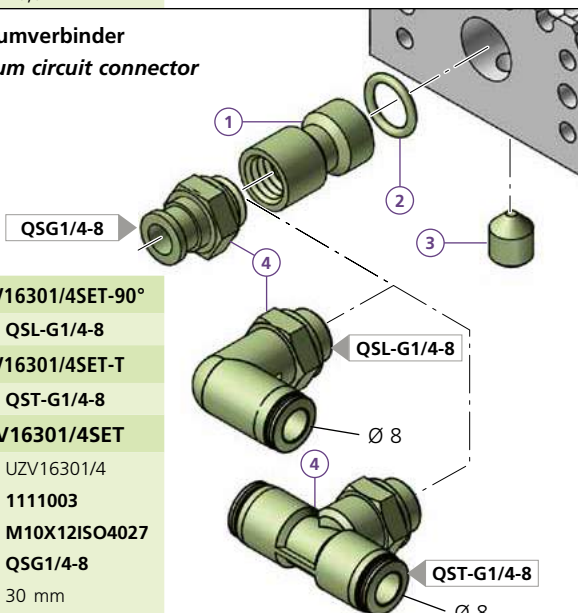

- UZV16301/4SET-90°**
- ④ 1x QSL-G1/4-8
- UZV16301/4SET-T**
- ④ 1x QST-G1/4-8
- UZV16301/4SET**
- ① 1x UZV16301/4
  - ② 1x 1111003
  - ③ 1x M10X12ISO4027
  - ④ 1x QSG1/4-8
- L = 30 mm
- kg ~0,024

Verbindungsschlauch mit Koppelementen  
Connector-tube with link-ups

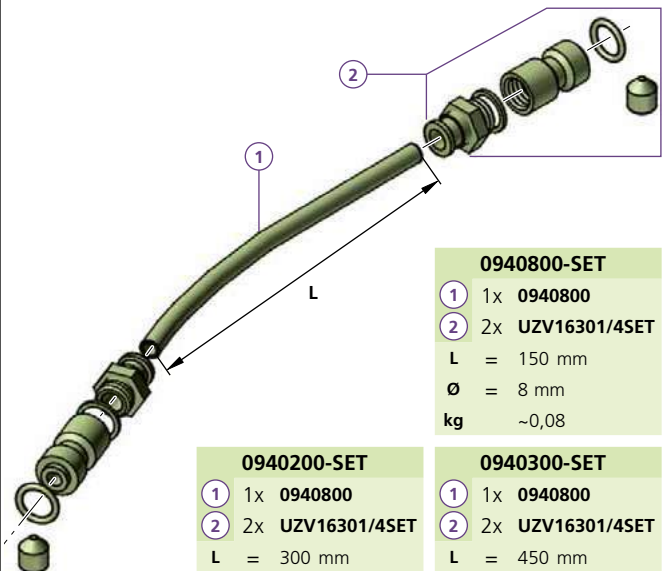

- 0940800-SET**
- ① 1x 0940800
  - ② 2x UZV16301/4SET
- L = 150 mm
- Ø = 8 mm
- kg ~0,08

- 0940200-SET**
- ① 1x 0940800
  - ② 2x UZV16301/4SET
- L = 300 mm
- Ø = 8 mm
- kg ~0,08

- 0940300-SET**
- ① 1x 0940800
  - ② 2x UZV16301/4SET
- L = 450 mm
- Ø = 8 mm
- kg ~0,09



#### Dichtschnüre aus Silikon-Gummi

Beständig gegen Öle, Säuren, Emulsionen, Dielektrika, ionisiertes Wasser und Wärme bis 200°C

#### Silicone-rubber sealing cord

Resistant to oils, acids, coolants, dielectrics, activated water (EDM) and heat up to 200°C

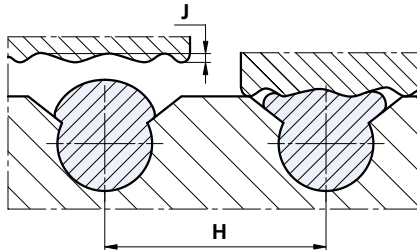

#### Dichtschnüre aus Gummi

- ölbeständig  
- für spezielle Vorrichtungen

#### Rubber sealing cord

- oil resistance  
- to fit special devices

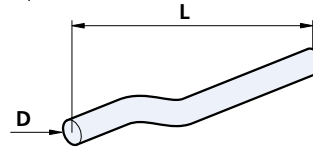

G13



G06

weiss / white

1110100	1120100	1120100M	1130000
L = 25 m	L = 25 m	L = 25 m	L = 5 m
D = 6,5 mm ±0,5	D = 4 mm (4,3-4,6 mm)	D = 4 mm (4,0-4,3 mm)	D = 3 mm
J = max. 0,6 mm	J = max. 0,4 mm	J = max. 0,3 mm	
H = 12-13 mm	H = 6-7 mm	H = 6-7 mm	



G13

schwarz / black

weiss / white

1110100S	1110100SP	0130001	0130002
L = 25 m	L = 25 m	L = 1 m	L = 1 m
D = 6,0-6,5 mm	D = 6,6-7,0 mm	D = 2,15 mm	D = 1,65 mm
J = max. 0,6 mm	J = max. 0,6 mm		
H = 12-13 mm	H = 12-13 mm		

#### Triva Clamp Ventil / Triva Clamp valve

Montage von oben  
Mounting from above

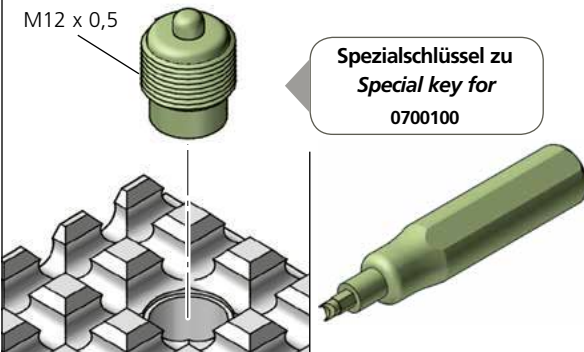

0700100	kg	~0,01	Triva Bit	kg	~0,14
---------	----	-------	-----------	----	-------

Ventil-Blindstopfen  
Valve blind plug

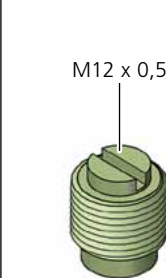

0700102	kg	~0,01
---------	----	-------

Montage von unten, für Spezialvorrichtungen  
Mounting from bottom side, for special devices

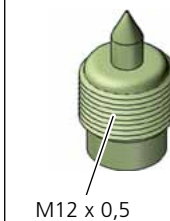

0700200	kg	~0,01
---------	----	-------

Reduktionstück für Rasterplatten M12/12<sup>f7</sup> auf M6  
Adapter piece for Gridplates from M12/12<sup>f7</sup> to M6

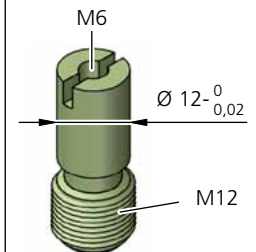

ADAPT6-12	kg	~0,02
-----------	----	-------

#### Schnellkupplung mit Bride Quick hose coupling including clip

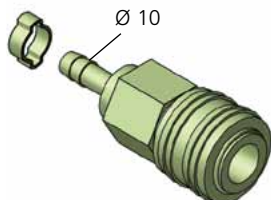

0520000	kg	~0,14
---------	----	-------

#### Schlauchnippel mit Bride Hose nozzle including clip

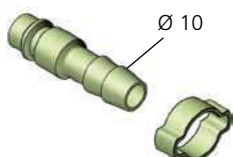

0941010	kg	~0,03
---------	----	-------

#### VHM Profilfräser für Vorrichtungplatten Carbide end mills for plate for dedicated fixtures

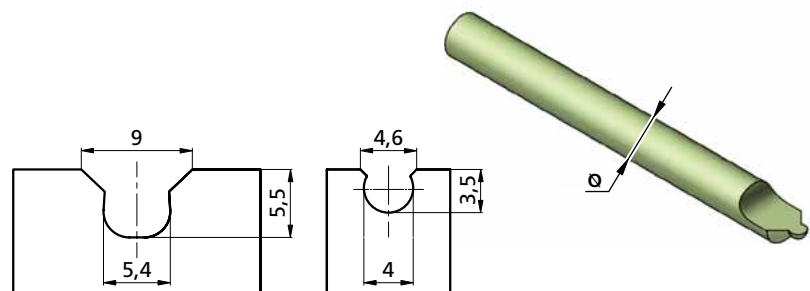

G13

VFP10065L100 (Ø 6,5 mm)

Ø = 10
L = 100



G06

VFP08040L90 (Ø 4 mm)

Ø = 8
L = 90



**Rotationspumpe auf Speichertank für Arbeiten mit Kühlwasser**

**Aggregat ausgerüstet mit:**

- Vakuumpumpe, Enddruck 20 mbar
- Wasserabscheider mit Sintermetallfilter
- Fahrbarem 50 Liter Behälter als Vakuumspeicher und Wasserreservoir
- 5 Meter Vakuumschlauch
- für 3-Phasenbetrieb wartungsfreie Drehstrommotoren
- für 1-Phasenbetrieb wartungsfreie Motoren mit Anlauf-Kondensatoren.

**für Vakuumaufspannflächen:**

- zusammenhängend, oder auf mehrere einzelne Platten verteilt

**Rotary pumptank assembly Pump assembly for machining with flowing coolant**

**Assembly equipped with:**

- Vacuum pump, pressure limit 20 mbar
- Liquid separator with sintered metall filter
- Pump mounted on a movable 50l (13gal) tank being both, vacuum reservoir and water collector
- 5 m (6.5ft) Vacuum hose
- maintenance-free motors for 3 phase operating
- single phase motors with capacitor starter.

**To cover maximum holding surface:**

- built by plate or plate-assembly, or display over several single plates mounted to various machine-tools

**Technische Daten  
Technical data**

**Saugkraft  
Suction capacity**

**Spannfläche bis / Surface up to 1,8 m<sup>2</sup>**

3-Phasen / Triple phase 400 V ± 10%, 50 / 60 Hz, 250 / 300 W	6 / 7,2 m <sup>3</sup> /h	<b>UBA306400250</b>
1-Phasen / Single phase 230 V ± 10%, 50 / 60 Hz, 300 / 360 W	6 / 7,2 m <sup>3</sup> /h	<b>UBA106230300</b>
1-Phasen / Single phase 110 V ± 10%, 50 / 60 Hz, 250 / 300 W	6 / 7,2 m <sup>3</sup> /h	<b>UBA106110250</b>

**Spannfläche bis / Surface up to 5,0 m<sup>2</sup>**

3-Phasen / Triple phase 400 V ± 10%, 50 / 60 Hz, 550 / 660 W	18 / 21 m <sup>3</sup> /h	<b>UBA318400550</b>
1-Phasen / Single phase 230 V ± 10%, 50 / 60 Hz, 600 / 720 W	18 / 21 m <sup>3</sup> /h	<b>UBA118230600</b>

**Separater Tank / Separate tank**

<b>UBT40</b>
Vol. 40l

**Öl für Vakuumpumpe / Oil for vacuum pump**

<b>UB1-OIL</b>
Vol. 1l



Bedienungsanleitung zu diesem Vakuumpumpen  
Operating instructions for this vacuum pump

➔ Größere Pumpen auf Anfrage  
➔ Larger pumps on demand



# Schaltventil und Druckwächter Control unit with pressure sensor switch

Schaltventil  
Control unit

TN100668 kg ~0,096

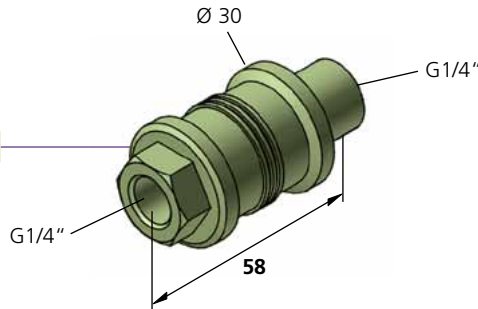

Schaltventil mit Unterdruckanzeige  
Control unit valve with vacuum indicator

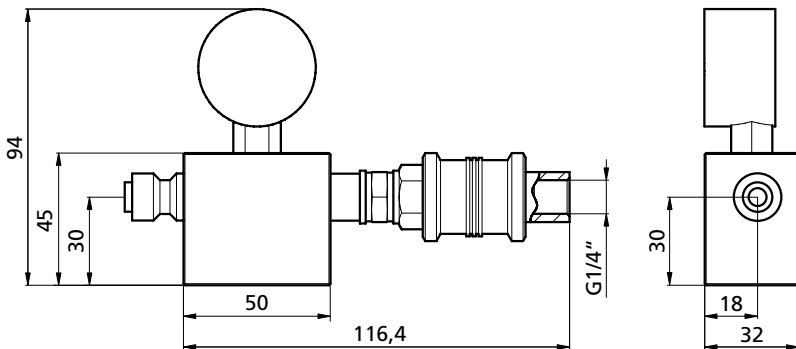

### UBS5045

- 1 1x UBS5045-1
- 2 1x 0910000
- 3 3x TN100822
- 4 1x 0920000
- 5 3x TN100086
- 6 1x TN100671
- 7 2x TN100642
- 8 1x TN100925
- 9 1x TN100668
- 10 1x TH120180

kg ~0,74

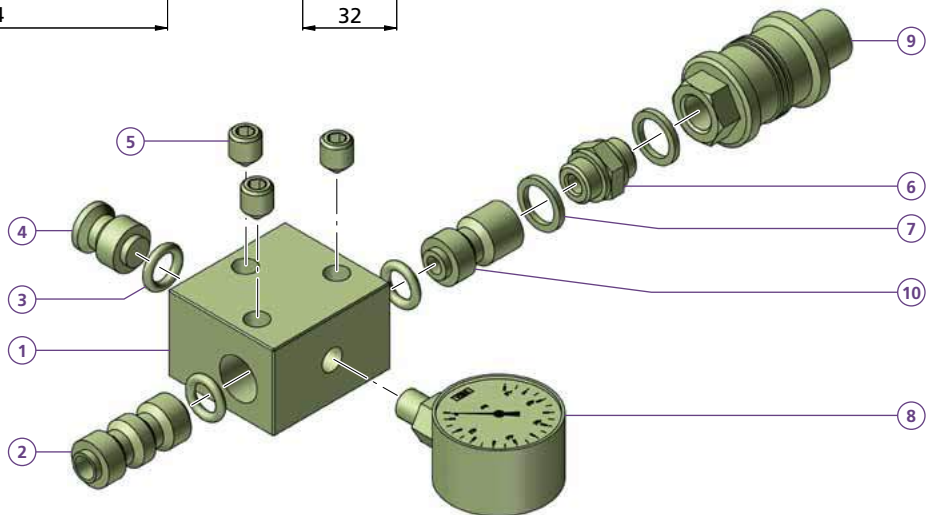

## Druckwächter / Pressure sensor switch

Druck einstellbar; je nach Aufspannung einzustellen.

With adjustable threshold value; to be adjusted according to clamping task.

Anschluss 24-250 V, 50-60 Hz am Ausgang (R) für Elektrokabel zu optischem oder akustischem Warnsignal, oder zum Stillsetzen der Werkzeugmaschine über deren Steuerung, normalerweise mit Funktion M 00 (Maschineninhalt).

Power supply (24-250 V, 50-60 Hz). Connecting point (R) for wiring to trigger a signal (light or whistle) or to switch the machine tool off via its control system, normally using function M 00 (machine stop), in the event of a drop of vacuum.

Winkelanschluss / Elbow fitting

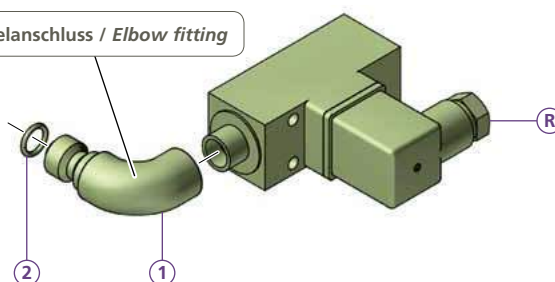

### 0500205

- 1 1x 0940000
- 2 1x 1111003

➔ Weiteres Zubehör auf Anfrage  
➔ Further accessories on demand



# Injektorpumpe

## Injector pump

UPB 1JN  
UPB 2JN

trivaCLAMP

### Vakuumschleuse auf Power-Clamp mit Injektorpumpe für Trocken- und Nasseinsatz

Das modulare Triag Power Clamp Spannsystem kann nun mit Vakuumschleusen bestückt werden. Die Vakuumschleusen können mit oder ohne Zwischenräume gekoppelt werden. Die handliche Injektorpumpe wird mit Druckluft betrieben und kann im Trocken- oder Nasseinsatz verwendet werden.

### Vacuum clamping plates on Power - Clamp with injector pump for dry and wet use

The modular Triag Power Clamp workholding system can now be equipped with vacuum plates. The vacuum plates can be coupled with or without gaps. The handy injector pump is operated with compressed air and can be used in dry and wet applications.

**Maximaler zulässiger Speisedruck: 7 bar**  
**Maximal erreichbares Vakuum: 0,92 bar**

**Maximum allowable supply pressure: 7 bar**  
**Maximum attainable vacuum: 0,92 bar**

Der Normalliter (NI) entspricht dem Volumen, das eine bestimmte Menge (Masse) Gas bei atmosphärischem Druck einnehmen würde. Die Durchflussmenge wird berechnet aus Volumen pro Zeit (NI/s) unter Normalbedingungen (atmosphärischer Druck, 20°C).

The normal litres (NI) is the volume that would take a certain amount (mass) of gas at atmospheric pressure. The flow rate is calculated as volume per time (NI/s) under normal conditions (atmospheric pressure, 20°C).

Typ	Speisedruck	Luftverbrauch	Saugleistung bei 50% Vakuum	Saugleistung bei 90% Vakuum
Type	Feed pressure	Air consumption	Vacuum suction power at 50%	Vacuum suction power at 90%
	bar	NI/s	NI/s	NI/s
UPB1JN	5	2,0	0,6	0,02
	6	2,3	0,5	0,03
UPB2JN	5	4,0	1,2	0,04
	6	4,6	1,0	0,06

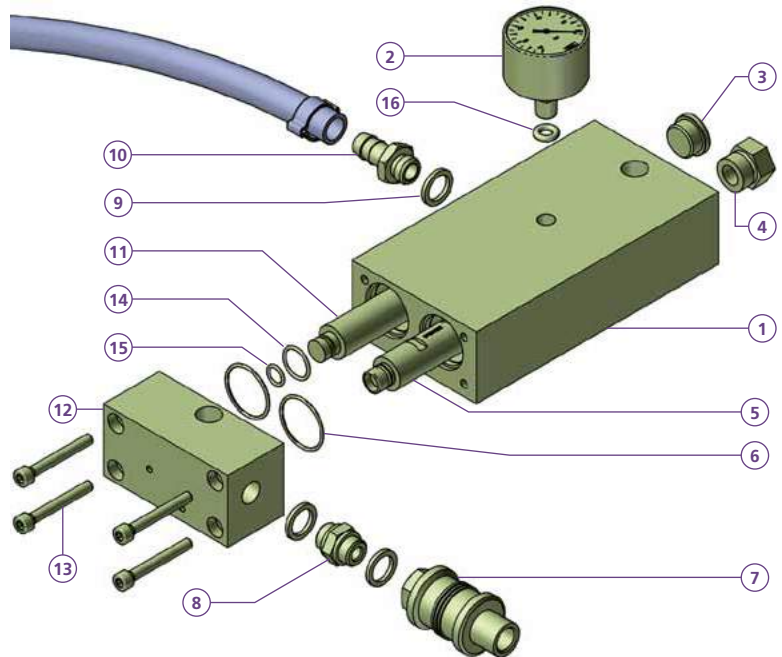
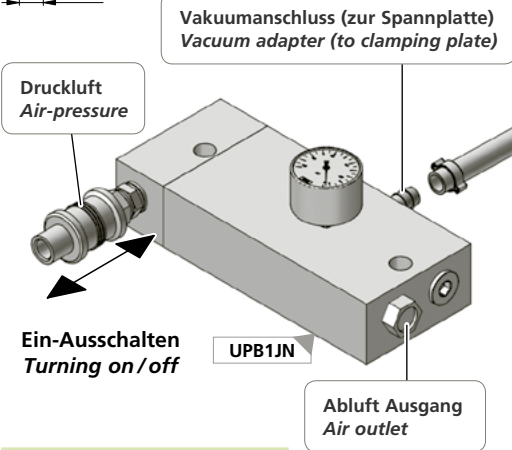
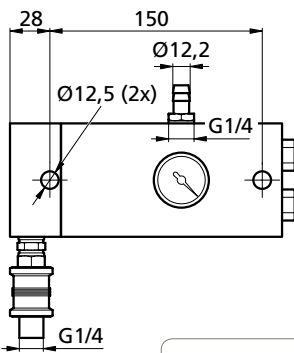
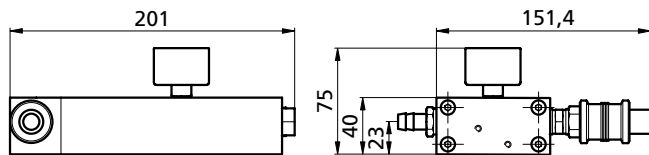

UPB1JN	
1	1x TW090057
2	1x TN100667
3	1x TN100660
4	1x TW100199
5	1x TN100665
6	2x TN100057
7	1x <b>TN100668</b>
8	1x TN100671
9	3x TN100642
10	1x TN100664
11	1x TW090057
12	1x TW90057-02
13	4x TN100666
14	1x TN100691
15	1x TN100163
16	1x TN100654
kg	~1,61

UPB2JN	
1	1x TW090057
2	1x TN100667
4	2x TW100199
5	2x TN100665
6	2x TN100057
7	1x <b>TN100668</b>
8	1x TN100671
9	3x TN100642
10	1x TN100664
12	1x TW90057-02
13	4x TN100666
14	1x TN100691
15	1x TN100163
16	1x TN100654
kg	~1,67

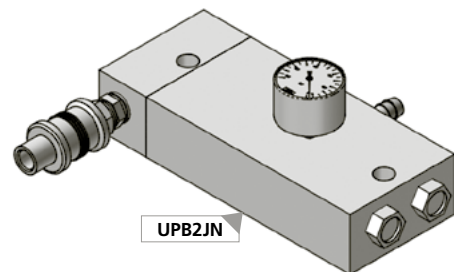

Bestellbeispiel / Ordering example: UPB1JN

Separat bestellen / Separate order





trivaCLAMP



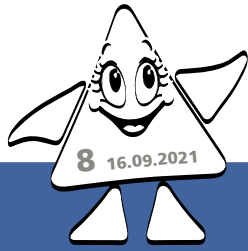

**triGEL**

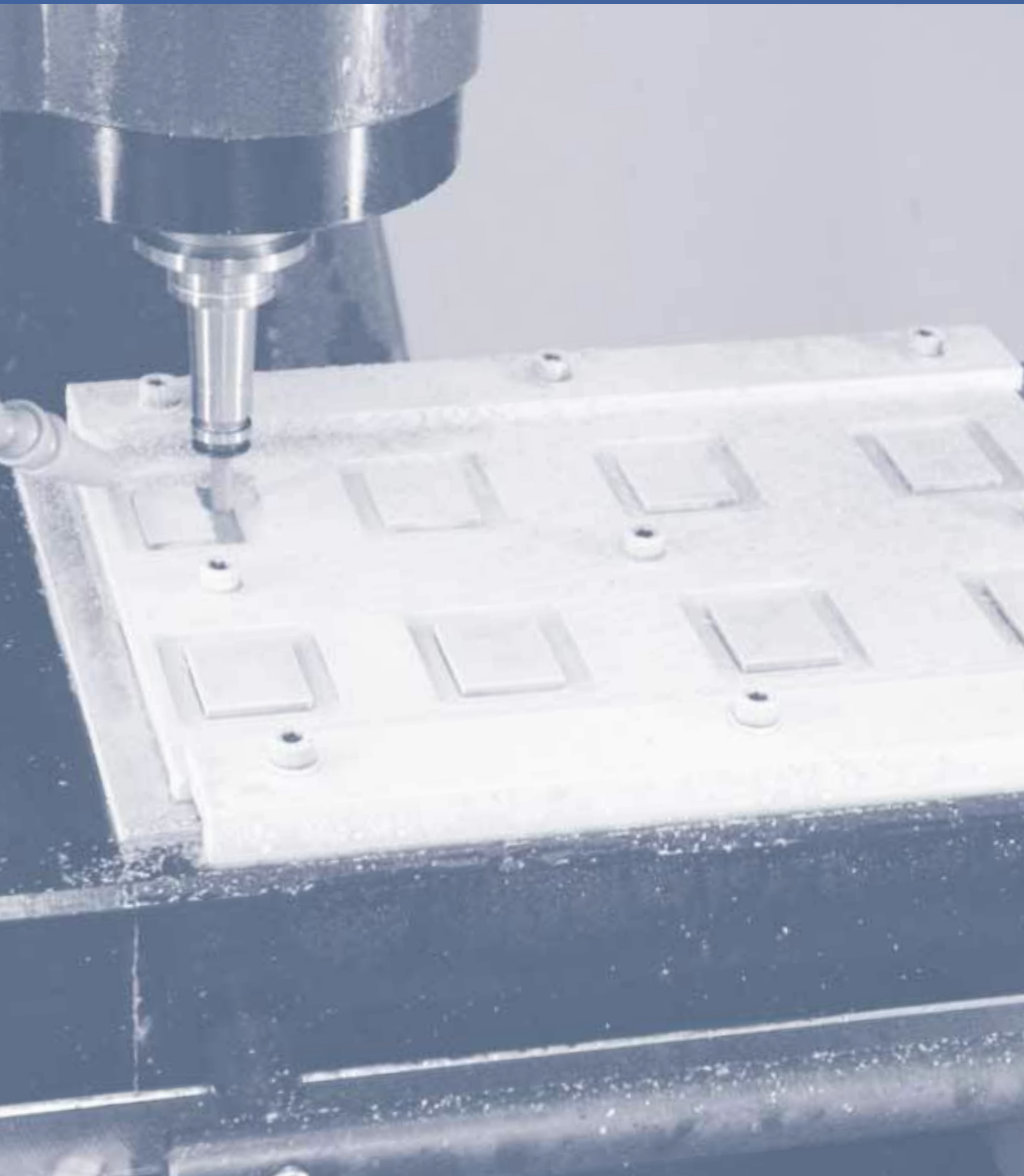



Beim Gefrierspannen werden Werkstücke festgefroren, ähnlich wie wenn man im Winter am Handlauf eines Metallgeländers "kleben" bleibt.

Diese Art von Spannung könnte thermo-elektrisch mit Halbleitern (Peltier-Effekt) oder durch Nutzung eines Kühlmediums erreicht werden. Wir haben uns für das zweite entschieden, weil es leistungsstärker ist. Dabei wird die Verdampfungskälte eines Kühlmediums (bei uns treibhausinaktives R4040) genutzt, das in einem geschlossenen Kühlkreislauf zirkuliert. Das kalte Gas wird durch das Kanallabyrinth des Arbeitstisches geleitet, wobei dessen Temperatur auf die normale Arbeitstemperatur von zirka  $-8^{\circ}\text{C}$  fällt.

Der Arbeitstisch und die Werkstücke werden durch einen Wasserzerstäuber mit einem feinen Wasserfilm überzogen. Dadurch frieren die Teile in ca. 15 bis 60 Sekunden an. Um die Werkstücke wieder zu lösen, wird der Vorgang umgekehrt. Das Gerät arbeitet dann quasi als Wärmepumpe, wodurch sehr schnell der Auftaupunkt wieder erreicht wird und die Werkstücke freigegeben werden.

Ungeeignet ist diese Methode dann, wenn im Zerspanungsprozess zuviel Wärme entsteht, da dadurch die Eisschicht aufgetaut werden kann. Dieses Problem kann mit gut geschärften Werkzeugen verkleinert werden. Das Haftvermögen ist mit  $2\text{N}/\text{mm}^2$  ( $\sim 2\text{t}/\text{dm}^2$ ) etwa 10 bis 20 mal höher als bei einer Vakuumspannung. Allerdings ist die Toleranz für harte mechanische Schocks kleiner. Die Dicke des Wasser- respektive Eisfilms ist vernachlässigbar klein. Unregelmässige Grundflächen werden in einem Wasserbad festgefroren. Spannbar sind alle metallischen, die meisten mineralischen Werkstoffe, sowie auch viele Kunststoffe. Heute findet das Spannen mit Eis nicht nur in der Uhren- und Schmuckindustrie seine Anwendung. Das Anwendungsfeld geht auch in die Medizintechnik und die allgemeine mechanische Fertigung.

*Fixturing with ice is using a physical effect. If we take hold of a metal handrail in the winter, when the temperature is below zero, we suddenly can find ourselves stuck to it.*

*Windshield wipers, door locks and handbrakes frozen into place demonstrate the same effect. This phenomenon is used by ice clamping devices. Those made by TRIAG are known as triGEL devices. There are two different methods of achieving the necessary cooling of the machine table (working surface): one is the Peltier effect, and the other is the use of a cooling medium as it is commonly applied in a deep freezer. In this second method, the latent heat of evaporation of the cooling medium (for example R4040 which has no greenhouse effect) contained in a closed coolant circuit is used. The cold gas passes through a labyrinth of channels in the machine table, bringing its temperature to about  $-8^{\circ}\text{C}$ .*

*Both the machine table and the workpieces are covered with a fine film of water using a water atomizer. This causes the workpiece to stick to the machine table within approximately 15 to 60 seconds. The process is reversed to release the workpieces. The device then operates rather like a heat pump, so that the dew point is reached again very quickly, and the workpieces are released.*

*The second method is significantly more powerful. TRIAG therefore uses this technique for their triGEL system. The adhesive strength, at  $2\text{N}/\text{mm}^2$ , is approximately 10 to 20 times greater than that of vacuum clamping. Hard mechanical shocks should nevertheless be avoided. Since no clamping forces are applied to the workpiece, parts with plane base surfaces can be machined with very high precision. The thickness of the film of water or ice is negligibly small. Irregular base surfaces can be frozen solid in a water bath. All metallic and most mineral materials, as well as many plastics, can be clamped in the way. Ice clamping is now no longer confined for use in the watch making and jewellery industries. The range of applications extends from medical technology through to general mechanical production.*





2 Beispiel Gefrierspannen: 2. Spannung Uhrehäusle aus Messing  
Example of fixturing with ice: 2nd clamping of brazen watch case

### Die triGEL-Vorrichtung setzt sich aus zwei miteinander verbundenen Funktionsteilen zusammen:

1. Ein Arbeitstisch aus Kupfer (100x100 mm, 100x200 mm, 200x300 mm, 170x450 mm, 500x550 mm), der als Kälte-tauscher dient.
2. Schaltkasten mit folgenden Funktionen:
  - Anschluss der elektrischen Aussenleitung (220 oder 380 V)
  - Steuerung und Regelung der Kühl- und Heiztemperaturen mit den optimalen Werten während der Arbeiten in der Gefrierphase, sowie des Auftauens.
  - Sicherheit für die elektromechanischen Elemente gegen elektrische Störungen.
  - Lichtsignale kontrollieren den Arbeitsablauf
  - Temperaturüberwachung und Störungsmeldung an die Maschinensteuerung

### The triGEL-fixture system consists of two connected members:

1. The workholding table made of thermo-conductive material (aluminum, copper). The refrigerating gas R4040 is circulating inside (100x100mm, 100x200mm, 200x300mm, 170x450mm, 500x550mm, custom made sizes on request).
2. The control cabinet including:
  - Compressor and heat exchanger 220 or 380V
  - Thermostatic control for the freezing and the reheating process, includes the maintaining of a preset temperature.
  - Electrical safety circuitry.
  - Control lights to watch the workholding process.
  - Interface to the machine control for process monitoring.

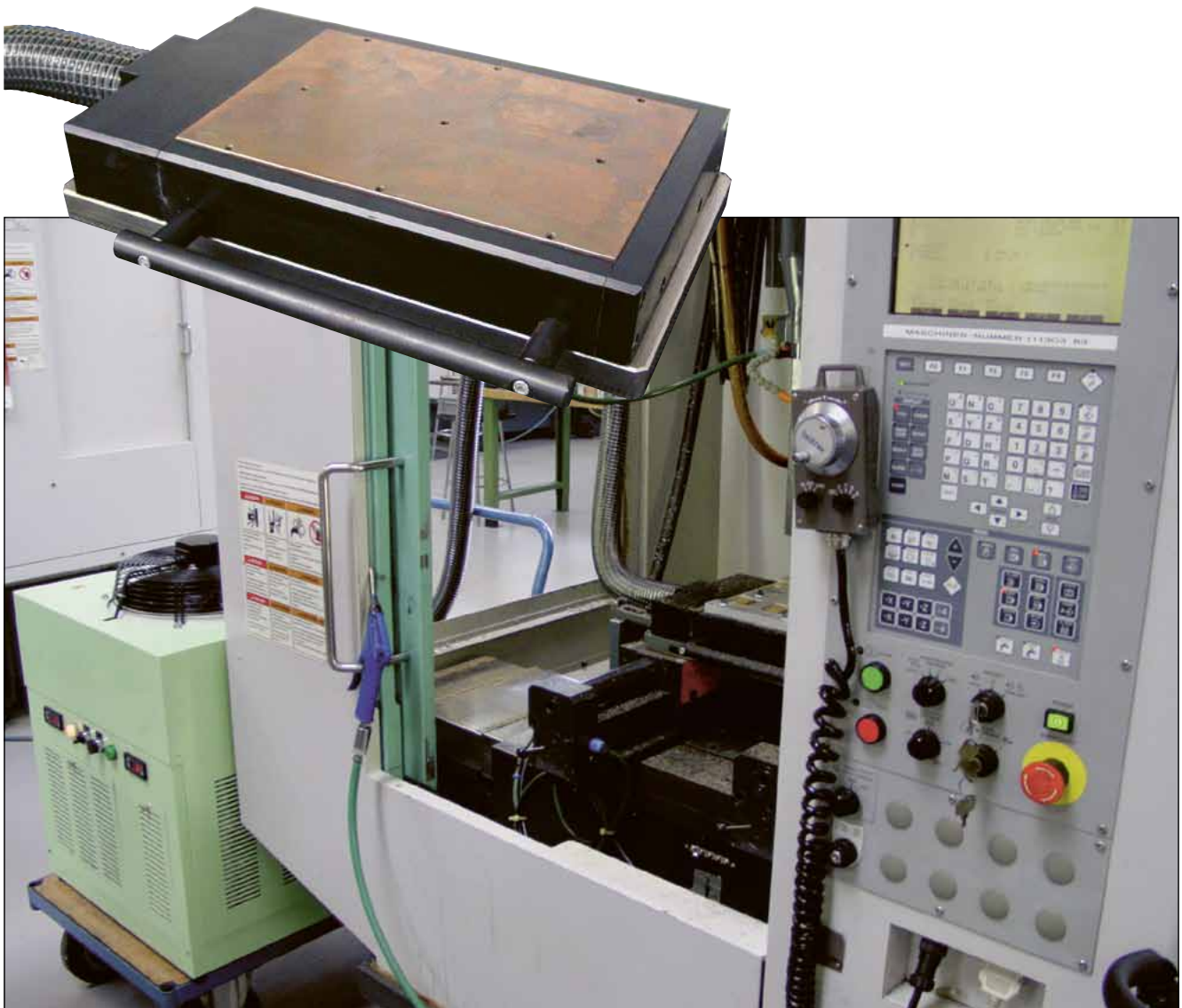



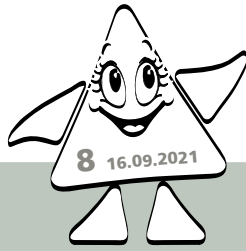
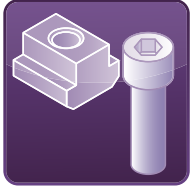

## Zubehör Accessories

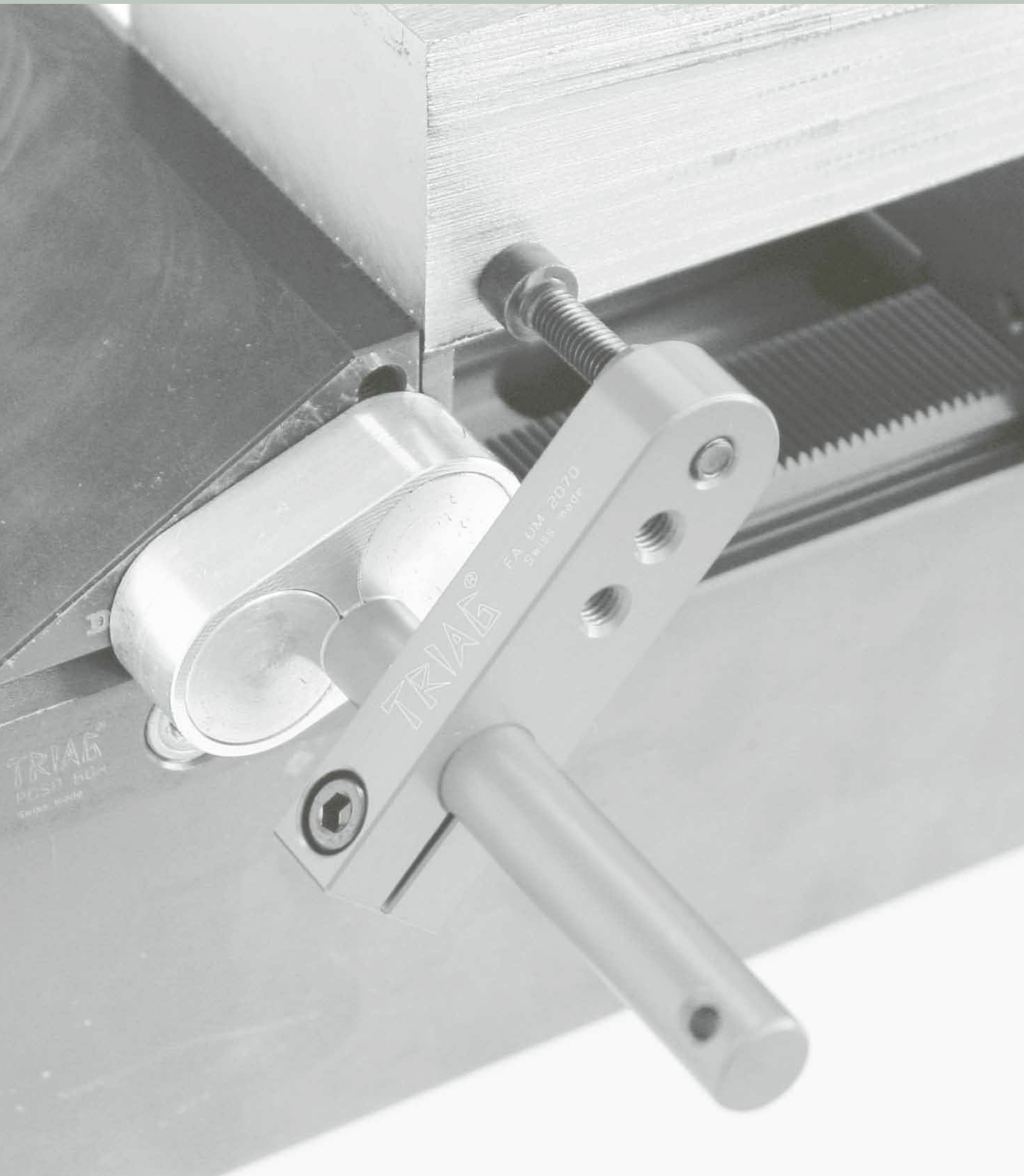





Einstellmasstab | *Measuring device* .....

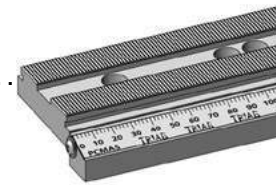

... 335

Magnetanschlag | *Magnetic milling buffer* .....



... 336

Fräsanschlag / Hartmetalldruckstück | *Milling buffer / Carbide gripper* .....

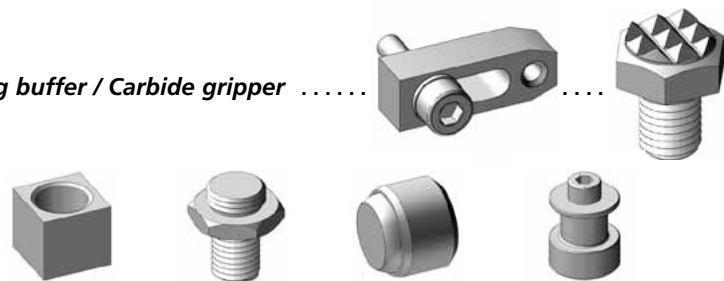

... 337

Stopfen / Spanschrauben / Passschrauben / T-Nuten Steine  
*Plug / Clamping screw / Fitting screw / T-slot nuts* .....

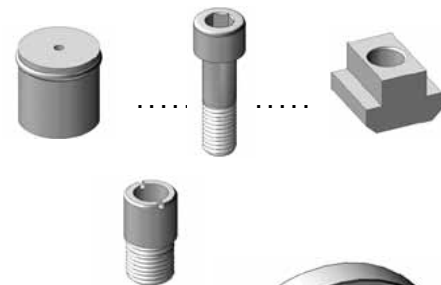

... 338

Triag Bitburr / Magnethalter / Pneumatikschrauber Set  
*Magnetic holder / Pneumatic screwdrivers set* .....

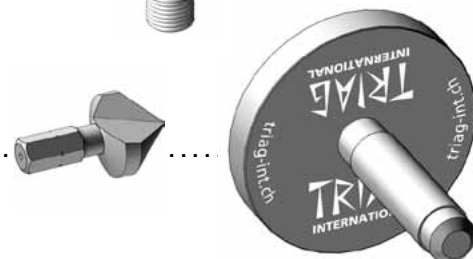

... 339

Drehmomentschlüssel / Spanschlüssel / Messingdrahtbürste  
*Torque wrenches / Clamping wrench / Brass wire brush* .....

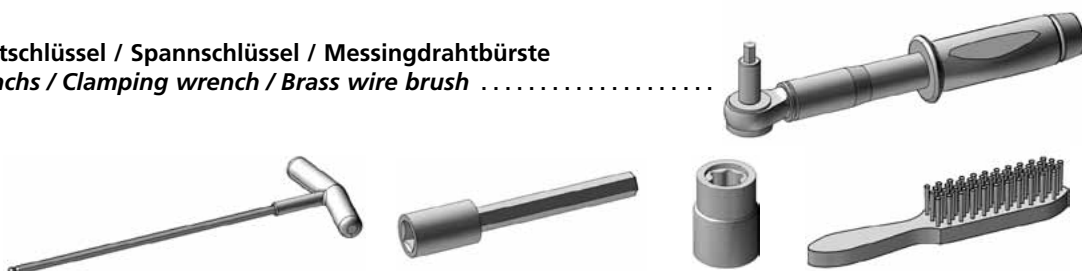

... 340



**Masstab mit Magnetleiste**  
*Scale with magnet profile*

- PCMAS800ML**
- ① 1x PCMAS800ML
  - ② 2x MG1645
  - ③ 2x M3X10ISO4762
  - ④ 1x M6X12BN5128
- kg ~1,0

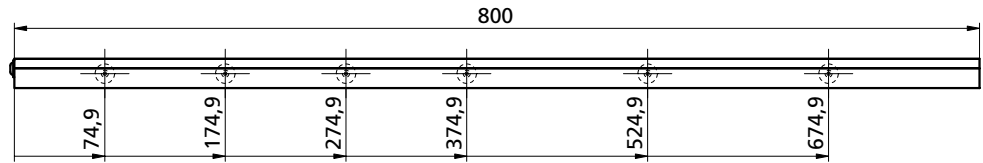

- PCMAS700ML**
- ① 1x PCMAS800ML
  - ② 2x MG1645
  - ③ 2x M3X10ISO4762
  - ④ 1x M6X12BN5128
- kg ~0,88

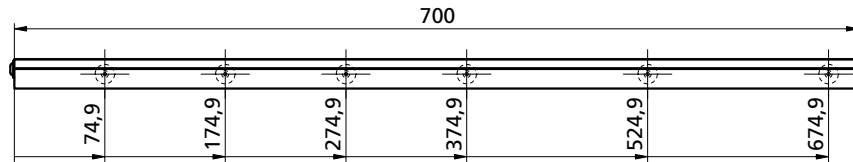

- PCMAS600ML**
- ① 1x PCMAS800ML
  - ② 2x MG1645
  - ③ 2x M3X10ISO4762
  - ④ 1x M6X12BN5128
- kg ~0,75

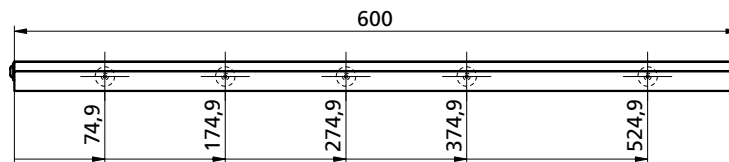

- PCMAS500ML**
- ① 1x PCMAS800ML
  - ② 2x MG1645
  - ③ 2x M3X10ISO4762
  - ④ 1x M6X12BN5128
- kg ~0,63

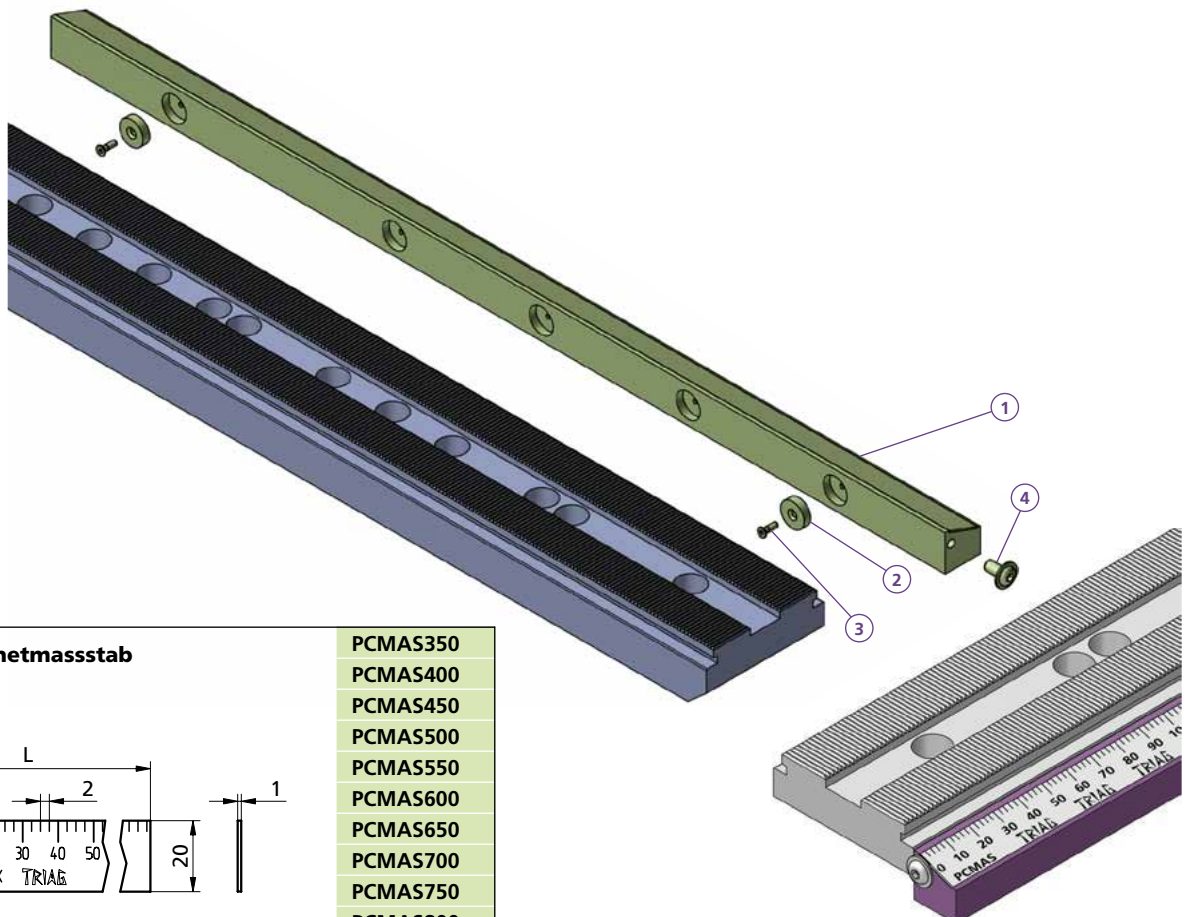
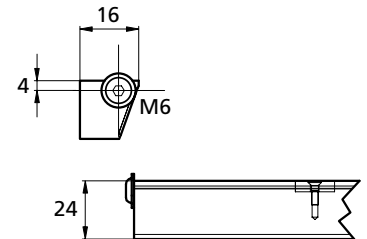
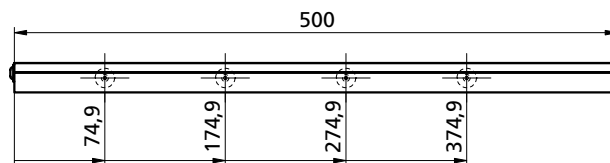

**Alu - Magnetmasstab**  
*Alu scale*

- PCMAS350
- PCMAS400
- PCMAS450
- PCMAS500
- PCMAS550
- PCMAS600
- PCMAS650
- PCMAS700
- PCMAS750
- PCMAS800

Bestellbeispiel / Ordering example : PCMAS800ML

Separat bestellen / Separate order

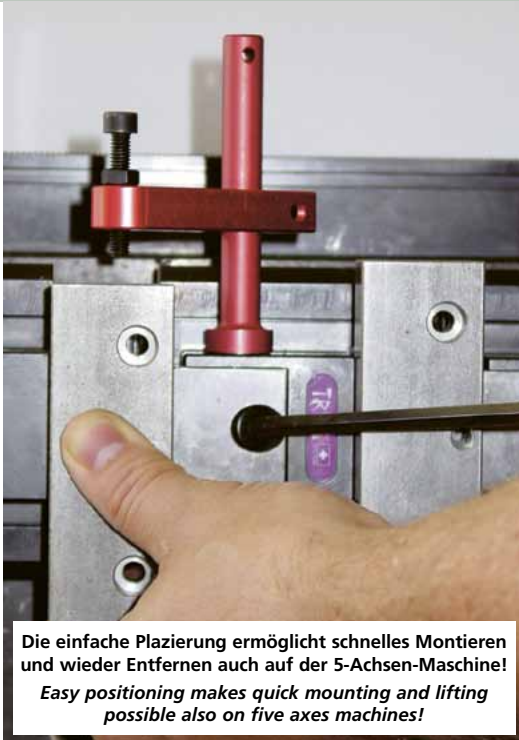

Die einfache Platzierung ermöglicht schnelles Montieren und wieder Entfernen auch auf der 5-Achsen-Maschine!  
 Easy positioning makes quick mounting and lifting possible also on five axes machines!

### Die 3 Sicherheitsstufen:

Durch seine rote Farbe ist der Anschlag besser sichtbar, was das Risiko vermindert, dass er in der Maschine vergessen wird.

Die Bohrung dient zum Befestigen einer Schnur am Handgelenk oder ausserhalb der Maschine.

Dank dem Magnet ist der Anschlag auf allen magnetischen Materialien auf minimalem Platz einsetzbar, bei Kollision wird er weggedrückt. Es entstehen so keine teuren Werkzeugbrüche oder Maschinendefekte.

### The 3 safety levels:

Because of its red color, the buffer is better visible. So the risk of forgetting the device in the machine is diminished.

The drilling serves to fasten a cord around the wrist or outside the machine.

Its magnet makes the buffer applicable on all magnetic materials on minimum space, in case of collision it gets pressed away, so there won't be any expensive breaking of tools or machines.

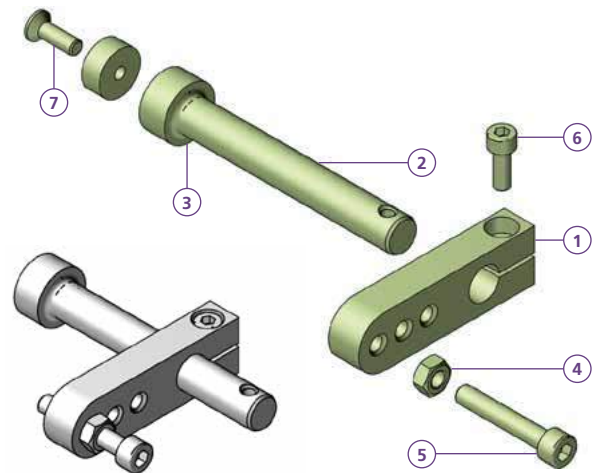
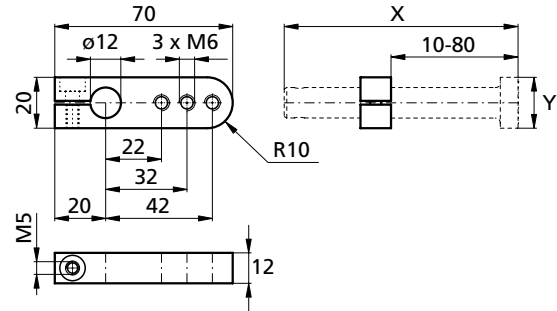

<b>Haltekraft / Holding force</b>	
45N = 4,5daN (~4,5 kg)	
<b>FAUM2070</b>	
1	1x FA2070
2	1x FAD2092
3	2x MG1645
4	2x M6ISO4032
5	1x M6X35ISO4762
6	1x M5X14ISO4762
7	1x M3X8ISO10642
X	= 92
Y	= $\varnothing$ 20
kg	~0,084

<b>Haltekraft / Holding force</b>	
80N = 8daN (~8 kg)	
<b>FAUM2070S</b>	
1	1x FA2070
2	1x FAD2092S
3	1x MG2570
4	1x M6ISO4032
5	1x M6X35ISO4762
6	1x M5X14ISO4762
7	1x M5X16ISO10642
X	= 95
Y	= $\varnothing$ 25
kg	~0,1

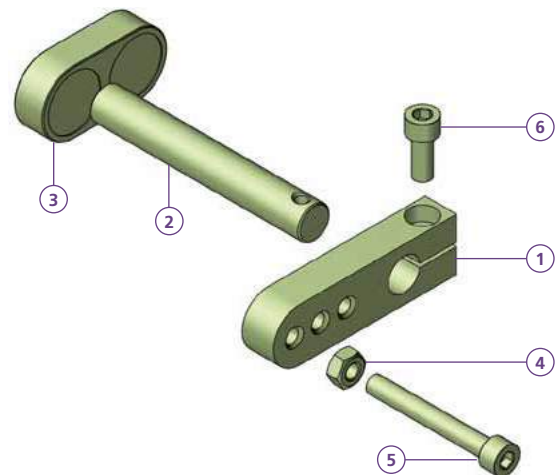
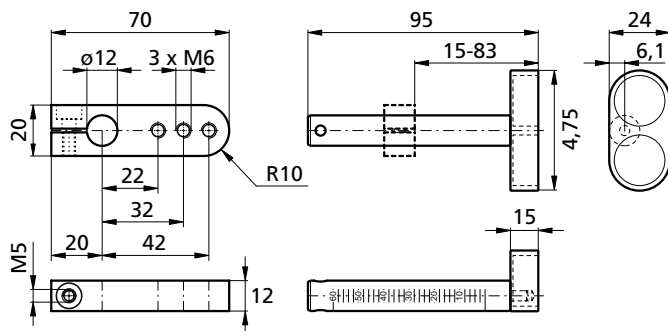

<b>Haltekraft / Holding force</b>	
120N = 12daN (~12 kg)	
<b>FAUM2070US</b>	
1	1x FA2070
2	1x FAD1280
3	1x FUSSUS
4	1x M6ISO4032
5	1x M6X35ISO4762
6	1x M5X14ISO4762
kg	~0,146

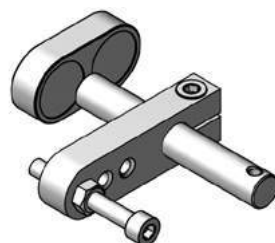

Bestellbeispiel Ordering example : FAUM2070US





**Fräsanschlag / Milling buffer**

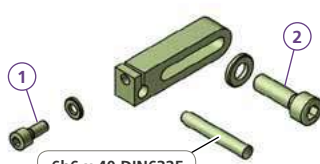
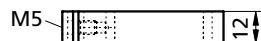
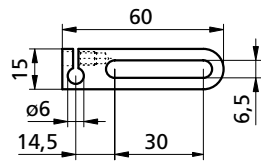
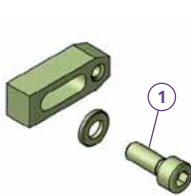
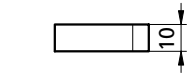
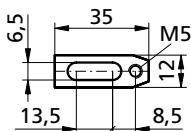

6h6 x 40 DIN6325

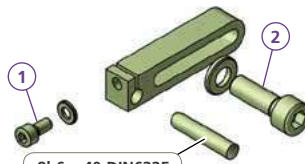
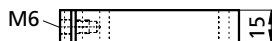
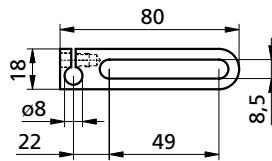

8h6 x 40 DIN6325

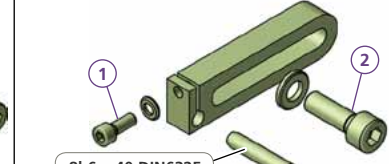
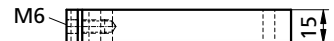
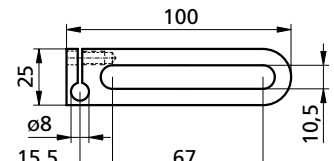

8h6 x 40 DIN6325

**FA1240**

1	1x M6X16ISO4762
2	1x M6X20ISO4762

kg ~0,024

**FA1260**

1	1x M5X12ISO4762
2	1x M6X20ISO4762

kg ~0,07

**FA1280**

1	1x M6X12ISO4762
2	1x M8X25ISO4762

kg ~0,014

**FA12100**

1	1x M6X16ISO4762
2	1x M8X25ISO4762

kg ~0,022

**Distanzbüchse zu Fräsanschlag  
Spacers for workpiece stop**

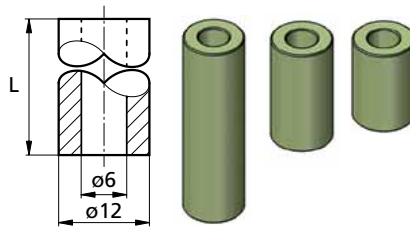
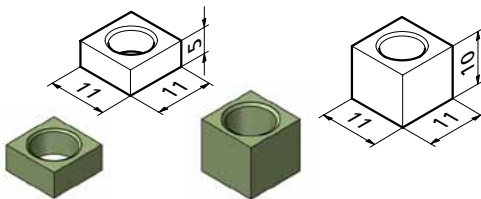

L	kg
FAD12018	18 ~0,012
FAD12023	23 ~0,016
FAD12040	40 ~0,026

CCD005      CCD010

**Positionierstift (spreizbar)  
Locating pin (expandable)**

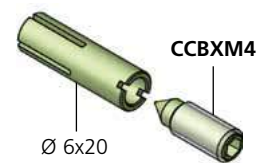

CCBX0802

**Druckstift / Gripping pins**

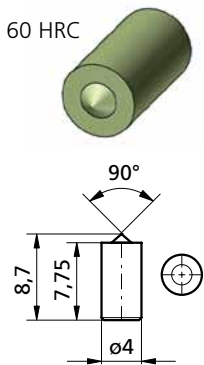

DS0402-90°

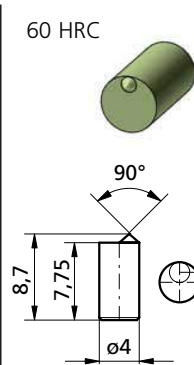

DSE0402-60°

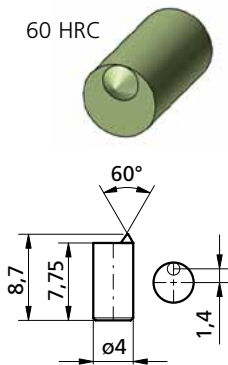

DSE0402-90°

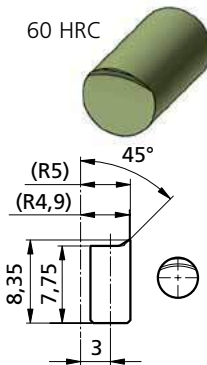

DSE0402-BS

**Einbauanleitung  
Installation guide**

Bohrung vorbereiten  
Preparation of drill-hole  
Einkleben mit / Glue with  
Loctite 641

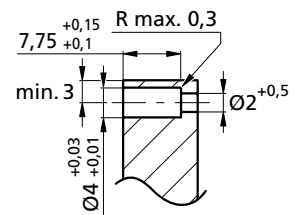

**Hartmetalldruckstück  
Carbide gripper**

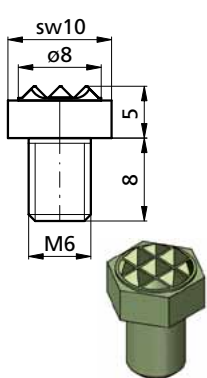

CCHMR

**Prägespanschraube  
Stamping roll screw**

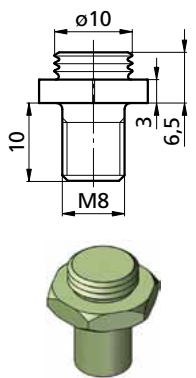

PRG1003M8

**Bohrbild  
Hole pattern**

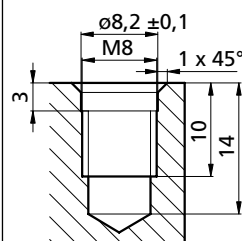

**Kugeldruckstück  
Gripper**

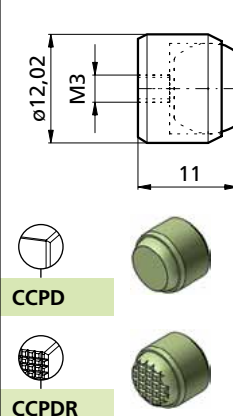

CCPDR

**Ausrichtzapfen für T-Nuten  
Alignment-pins for t-slots**

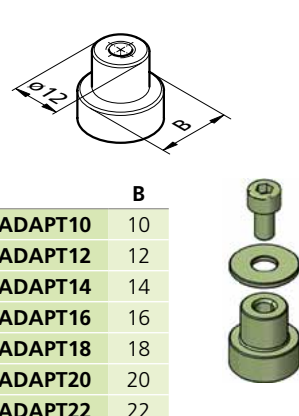

	B
TWADAPT10	10
TWADAPT12	12
TWADAPT14	14
TWADAPT16	16
TWADAPT18	18
TWADAPT20	20
TWADAPT22	22

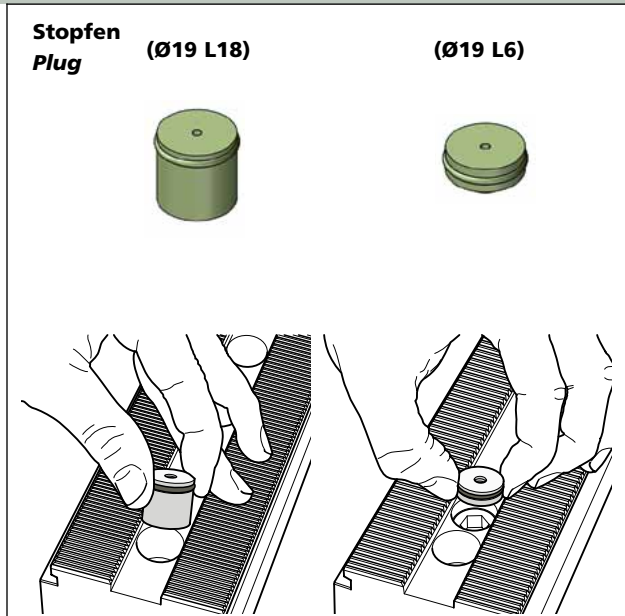

PCPF16L18      PCPF16L6

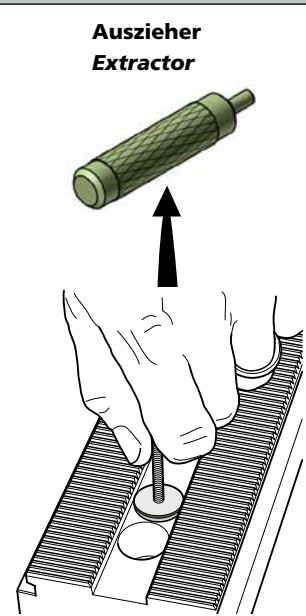

PCAZM3

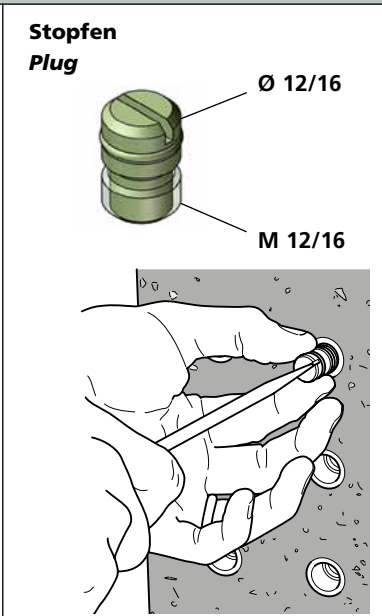

CCPF12ALU / CCPF16ALU

**Spannschrauben (Nitriert)**  
**Clamping screw (Nitrided)**

für/for kg

M8x20ISO4762NQ	B60	~0,012
M10x25ISO4762NQ	B80	~0,024

**Passschrauben / Fitting screw**

M5 / M6 / M12 / M16

**Reduktionshülsen für Rasterplatte**  
**Reduction sleeve for grid plate**

RD18M1612M12    RD16M1612M12    RD16M12

	D	G	L	B	K	sw	Nm	kg
MS50	5 f7	M5	17	9	5	4	4,5	~0,004
MS60	6 f7	M6	17	9	6	5	8	~0,006
TWPAS1250	12 g7	M12	50	30	12	10	60	~0,058
TWPAS1240	12 g7	M12	40	20	12	10	60	~0,048
TWPAS1232	12 g7	M12	32	19	12	10	60	~0,042
TWPAS1227	12 g7	M12	27	14	12	10	60	~0,038
TWPAS16055	16 f7	M16	55	30	15,8	14	150	~0,120

**T-Nuten Steine / T-slot nuts**

d	α	kg
SM1135 M06X08	~0,012	
SM1135 M06X10	~0,012	
SM1135 M08X10	~0,012	
SM1135 M08X12	~0,022	
SM1135 M08X14	~0,04	
SM1135 M10X12	~0,02	
SM1135 M10X14	~0,038	
SM1135 M12X14	~0,045	
SM1135 M12X16	~0,045	
SM1135 M12X18	~0,078	
SM1135 M12X20	~0,13	
SM1135 M14X16	~0,188	
SM1135 M14X18	~0,188	
SM1135 M16X18	~0,068	
SM1135 M16X20	~0,11	
SM1135 M18X20	~0,11	
SM1135 M18X22	~0,15	
SM1135 M18X22	~0,15	
SM1135 M20X22	~0,15	
SM1135 M20X24	~0,23	
SM1135 M24X28	~0,31	

**Bohrbüchsen**  
**Position case**

	L	D	d
CCBUE121812	12	18,0	12,0
CCBUE1218512	12	18,5	12,0
CCBUE121912	12	19,0	12,0
CCBUE162616	16	26,0	16,0

**Nutensteine, flach**  
**Low slot tenons**

Einsatzgehärtet, brüniert, geschliffen  
Case-hardened, blackened, ground

	b	H	L	d1	d2	t	inkl. Schrauben incl. screws	kg
SM1136-12	8	20	5,5	10	5,3		M5x12	~0,019
SM1136-14							M6x16	~0,021
SM1136-16							M6x16	~0,026
SM1136-18	10	22	6,6	11	6,3		M6x16	~0,03
SM1136-20							M6x16	~0,034

**Nutensteine, fest**  
**Fixed slot tenons**

Einsatzgehärtet, brüniert, geschliffen  
Case-hardened, blackened, ground

	H	L	b	Nutenmass slot size	inkl. Schrauben incl. screws	kg
NT2012		22	12	20	M6x10	~0,022
NT2014			14	20	M6x10	~0,026
NT2016		10	25	16	M6x10	~0,028
NT2018			18	20	M6x10	~0,03
NT2022		12	32	22	M6x12	~0,05
NT2024			24	20	M6x12	~0,055

# Pneumatikschrauber Set

## Pneumatic screwdrivers set

### Triag Bitburr / Triag Bit



## Zubehör / Accessories

### Pneumatikschrauber Set

#### Pneumatic screwdrivers set

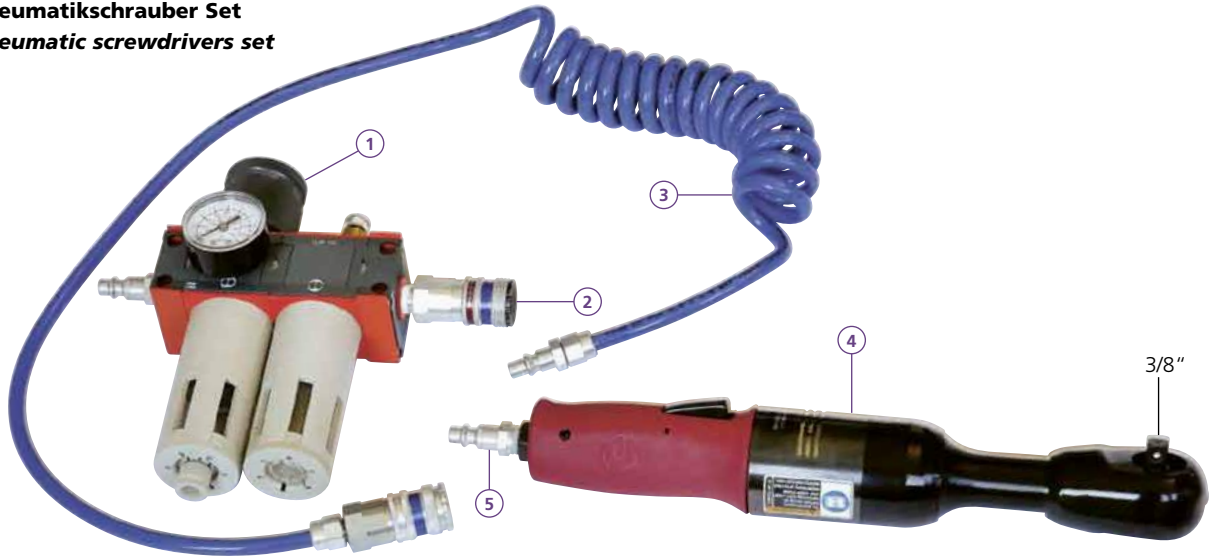

#### RP9431SET

- ① 1x P1H-200-M3QG
  - ② 1x 103002152 (SERIE 300) 1/4"
  - ③ 1x 199589977 (5 x 8 mm, 300, 2 m)
  - ④ 1x RP9431
  - ⑤ 2x 103105152 1/4"
- kg ~1,5

Drehmomenttabelle / Torque table	Druck / Compression (bar)	Nm
	6	50
Schlauchdurchmesser 8 mm	5,5	45
Luftverbrauch 2,5 L Sek	5	40
	4,5	35
Hose diameters 8 mm	4	30
Air consumption 2,5 L sec	3,5	25
	3	20

mit Feder gehalten, nicht magnetisch  
spring locked, not magnetic



mit Feder gehalten, nicht magnetisch  
spring locked, not magnetic



siehe Video  
see video

#### Triag Bit

#### Triag Bitburr

### Luftpistolen Gummiadapter

#### Air gun rubber adapter

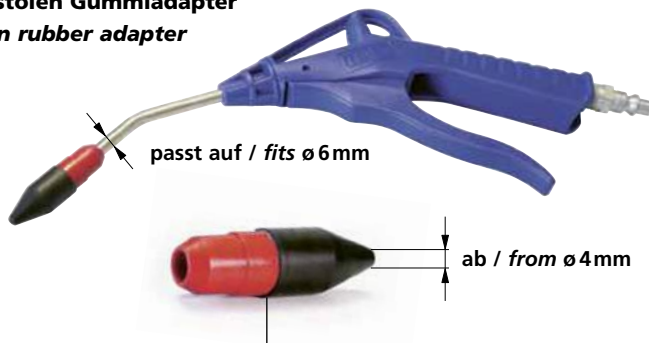

#### ARA14

### Magnethalter

#### Magnetic holder

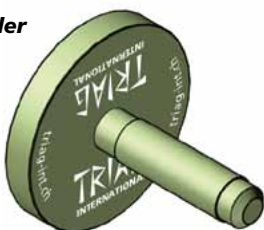

#### Smiley

### Einsatz für Triva Bit

#### Insert for Triva Bit



#### BitT

### Einsätze zu Bitburr

#### Inserts for Bitburr



#### TC10



#### BitF63 Ø 6,3-90°



#### BIT-KH



#### BitF104 Ø 10,4-90°



#### BIT-BF



#### BitF165 Ø 16,5-90°

Bestellbeispiel / Ordering example: RP9431SET





**Drehmomentschlüssel**  
**Torque wrench**

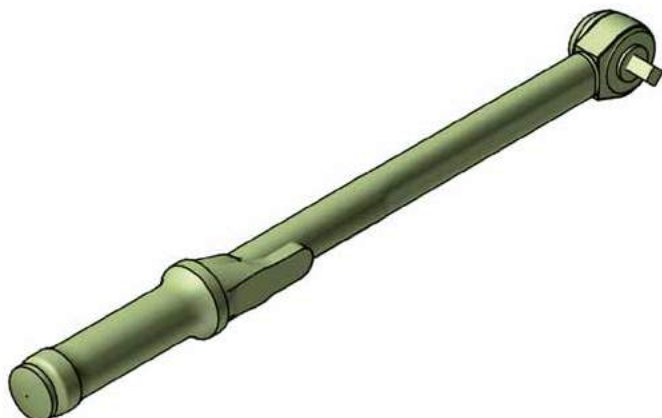

SL3 20-200 Nm (1/2")

**Sechskantstifteinsatz**  
**Hexagonal socket wrench**

(L) lang (L) long  
(LK) lang mit Kugelkopf (LK) long with ball head

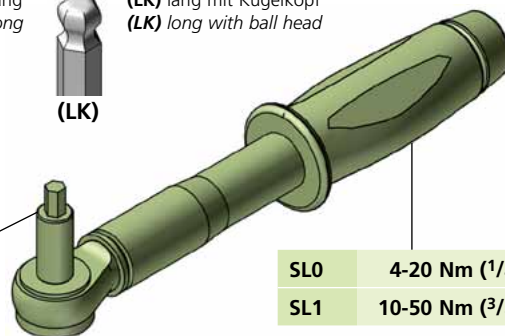

SL0 4-20 Nm (1/4")  
SL1 10-50 Nm (3/8")

NUSS1/4"4MM	4 mm	NUSS3/8"6MM	
NUSS1/4"5MM	5 mm	NUSS3/8"6MML	6 mm
NUSS1/4"6MM	6 mm	NUSS3/8"6MMLK	
NUSS1/4"8MM	8 mm	NUSS3/8"8MM	
		NUSS3/8"8MML	8 mm
		NUSS3/8"8MMLK	
NUSS3/8"5MM		NUSS3/8"10MM	
NUSS3/8"5MML	5 mm	NUSS3/8"10MML	10 mm
NUSS3/8"5MMLK		NUSS3/8"10MMLK	

**Steckschlüsseinsatz**  
**Socket wrench insert**



NUSS3/8"TX30E14	für / for	MCZ, ZSX, ZSM, ZSB, PCZ
NUSS1/4"4.5MM	4,5 mm	für / for MCZ40L30,
NUSS1/4"5.5MM	5,5 mm	UB5AXSET3, PCZ80L40PRG62

**Sechskantstifteinsatz**  
**Hexagonal socket wrench**

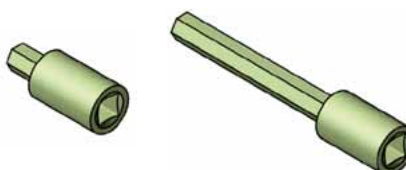

NUSS1/2"8MM	NUSS1/2"14MML
NUSS1/2"10MM	
NUSS1/2"14MM	



AD-BIT-1/4-1/4



AD-BIT-1/4-3/8

**Spannschlüssel**  
**Clamping wrench**



02613160	4 mm
02613164	5 mm
02613168	6 mm
02613172	8 mm
02613176	10 mm

**Langer Spannschlüssel**  
**Long clamping wrench**

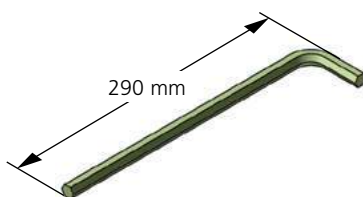

ISL10	sw = 10 mm
ISL14	sw = 14 mm

**Messingdrahtbürste**  
**Brass wire brush**

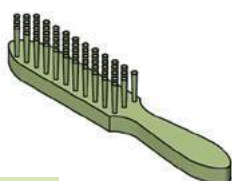

PCMB4



Triag Ei



**KALST powerCLAMP**

- 1 7x
- 2 1x PCB...
- 3 16x
- 4 16x

**KALST aptoCLAMP**

- 1 7x
- 2 1x ACB...
- 3 16x
- 4 16x



# Index

**5AXMCZ100-45-3** 136  
**5AXMCZ100-45-4** 134  
**5AXMCZ100-45-4H** 135  
**5AXMCZ100-45-8** 135  
**5AXMCZ100-45-12** 135  
**5AXMCZ100-90-4** 134  
**5AXZSX35-3** 154  
**0130001** 324  
**0130002** 324  
**0500205** 326  
**0520000** 324  
**0700100** 314, 315, 316, 317, 318, 324  
**0700102** 314, 315, 316, 317, 324  
**0700200** 324  
**0802000-SET** 322  
**0910000** 323, 326  
**0910001** 314, 315, 316, 317, 318, 323  
**0910080** 323  
**0920000** 314, 315, 316, 317, 318, 319, 323, 326  
**0930000** 323  
**0940200-SET** 323  
**0940300-SET** 323  
**0940800** 323  
**0940800-SET** 323  
**0941000** 321, 323  
**0941010** 324  
**1110100** 314, 315, 316, 317, 321, 324  
**1110100S** 324  
**1110100SP** 324  
**1111003** 314, 315, 316, 317, 318, 319, 323, 326  
**1120100** 314, 315, 316, 317, 318, 319, 321, 324  
**1120100M** 324  
**1130000** 324  
**02613160** 340  
**02613164** 340  
**02613168** 340  
**02613172** 340  
**02613176** 340  
**4700347** 53  
**7105230** 53  
**7105250** 53  
**7105520-49** 53  
**7105560-49** 53  
**7105770** 53

## A

**AA5X115-50** 228  
**AA5X125-50** 229  
**AA5X125-50VB** 231  
**AA5X150-50** 230  
**AAND115-50** 228  
**AAND125-50** 229  
**AAND150-50** 230  
**AC1505520W** 233  
**AC1505540W** 233  
**ACB4050400** 222  
**ACB4050450** 222  
**ACB4050500** 222  
**ACB4050550** 222  
**ACB4050600** 222  
**ACB4050650** 222  
**ACB4050700** 222  
**ACB4050750** 222  
**ACB4050800** 222  
**ACBS1646** 233  
**ACD005** 223, 224, 225, 227

**ACES6540** 232  
**ACES10040H25W** 232  
**ACES10240H07** 232  
**ACGGB103048** 227, 231  
**ACPB103048** 227, 231  
**ACU21124** 232  
**ACU36124** 232  
**ACU41124** 232  
**ACU46124** 232  
**ACUH21-124** 233  
**ACWB103048** 227, 231  
**ACZ56540** 232  
**ADAPT6-12** 317, 324  
**AD-BIT-1/4-1/4** 340  
**AD-BIT-1/4-3/8** 340  
**ARA14** 339  
**AS1F150N50-80** 226  
**AS1R150N50-80** 226  
**AS2F115N50-80** 223  
**AS2F125N50-80** 224  
**AS2F150N50-80** 225  
**AS2R115N50-80** 223  
**AS2R125N50-80** 224  
**AS2R150N50-80** 225  
**AS2X125L50-105** 227  
**AS25X115N50-80** 223  
**AS25X125L50-105** 227  
**AS25X125N50-80** 224  
**AS25X150N50-80** 225  
**AS35** 47, 146, 151  
**AS60** 47, 146, 151  
**AS80** 47, 146, 151

## B

**B01** 182, 183, 184, 185  
**B02** 182, 183, 184, 185  
**B03** 182, 183, 184, 185  
**B04** 182, 183, 184, 185  
**B05** 182, 183, 184, 185  
**B05R** 182, 183, 184, 185  
**B07** 178, 179, 180  
**B08** 178, 179, 180  
**B09** 178, 179, 180  
**B09+2** 178, 179, 180  
**B09+5** 178, 179, 180  
**B13** 61, 71, 181  
**B14** 61, 71, 181  
**B15** 61, 71, 181  
**B16** 61, 71, 181  
**B20** 60, 186  
**B21** 60, 186  
**B22** 60, 186  
**B26** 62, 187  
**B27** 62, 187  
**B28** 62, 187  
**B30** 197  
**B31** 197  
**B32** 197  
**B33** 197  
**B36** 190  
**B37** 190  
**B38** 190  
**B45** 63, 72  
**B46** 63, 72  
**B47** 63, 72  
**B47HM** 63, 72  
**B51** 198, 201  
**B52** 198, 201  
**B53** 198, 201  
**B54** 198, 201  
**B55** 198, 201  
**B58** 64, 73, 188, 189, 191, 192, 194,

195  
**B60** 54, 56, 64, 73, 188, 189, 191, 192, 194, 195, 194  
**B61** 64, 73, 188, 189, 191, 192, 194, 195  
**B62** 64, 73, 188, 189, 191, 192, 194, 195  
**B62HM** 64, 73, 188, 189, 191, 192, 194, 195  
**B65** 64, 73, 188, 189, 191, 192, 194, 195  
**B66** 64, 73, 188, 189, 191, 192, 194, 195  
**B67** 64, 73, 188, 189, 191, 192, 194, 195  
**B68** 64, 73, 188, 189, 191, 192, 194, 195  
**B69** 64, 73, 188, 192  
**B77** 64, 73, 188, 189, 191, 192, 194, 195  
**B78** 59, 198, 201  
**B79F** 64, 73, 188, 189, 191, 192, 194, 195  
**B79R** 64, 73, 188, 189, 191, 192, 194, 195  
**B80** 54, 56, 65, 66, 67, 223, 224, 225, 226, 226  
**B80N** 59, 65, 66, 67, 223, 224, 225, 226  
**B81** 65, 66, 67, 223, 224, 225, 226  
**B82** 65, 66, 67, 223, 224, 225, 226  
**B82HM** 65, 66, 67, 223, 224, 225, 226  
**B82L33** 65, 66, 67, 223, 224, 225, 226  
**B83** 65, 66, 67, 223, 224, 225, 226  
**B84** 65, 66, 67, 223, 224, 225, 226  
**B89F** 65, 66, 67, 223, 224, 225, 226  
**B89R** 65, 66, 67, 223, 224, 225, 226  
**B90** 54, 56, 59, 68  
**B90F78** 59, 69  
**B90R78** 59, 69  
**B90W78** 69  
**B91** 68  
**B92** 68  
**B93** 59, 68  
**B94** 68  
**B95** 54, 56, 70, 193  
**B96** 70, 193  
**B97** 70, 193  
**B98** 70, 193  
**B99** 70, 193  
**B105** 59, 77, 79, 80, 81, 84, 107, 199, 200, 227  
**B105-15** 84, 107, 199  
**B105H20** 82  
**B105P** 84, 199  
**B106** 59, 84  
**B106H20** 82  
**B106P** 84  
**B107** 84  
**B107H20** 82  
**B107P** 84  
**B108** 84  
**B108P** 84  
**B110** 59, 79, 84  
**B110H20** 82  
**B110P** 84  
**B111** 59, 84  
**B111H20** 82  
**B111P** 84  
**B112** 84  
**B112E** 84

**B112EP** 84  
**B112H20** 82  
**B112HG** 84  
**B112P** 84  
**B113** 84  
**B113P** 84  
**B115** 74, 84, 199, 227  
**B115P** 59, 84  
**B116P** 84  
**B117P** 84  
**B120** 75, 84, 199, 227  
**B120P** 59, 80, 84  
**B122P** 78  
**B123P** 76  
**B130H20P** 83  
**B131H20P** 83  
**B132H20P** 83  
**B140** 59, 84  
**B140P** 84  
**B141** 59, 84  
**B141P** 84  
**B151** 196  
**B170** 126, 127, 128, 132  
**B172** 128, 130, 132  
**B172-MB** 130  
**B173-26** 129, 132  
**B173-45** 129, 132  
**B173-64** 129, 132  
**B173-83** 129, 132  
**B173-102** 129, 132  
**B173-MB** 130  
**B173SET** 129  
**B175-26** 128, 132  
**B175-45** 128, 132, 136  
**B175-64** 128, 132  
**B175-83** 128, 132  
**B175-102** 128, 132  
**B175-121** 128, 134, 135  
**B175-MB** 130  
**B175SET** 128  
**B176-80** 129, 132  
**B190-13** 116, 117  
**B190-22** 116, 117  
**B190-31** 116, 117  
**B190W6-40** 117  
**B190W10-40** 117  
**B190W20-40** 117  
**B190W30-40** 117  
**B210-62** 123, 124  
**B212W11-60** 123, 124  
**B212W20-60** 123, 124  
**B222** 156  
**B301** 105  
**B310** 105  
**B311** 105  
**B312** 105  
**B313** 105  
**BIT-BF** 339  
**BitF63** 339  
**BitF104** 339  
**BitF165** 339  
**BIT-KH** 339  
**BitT** 339  
**BL-SET** 108

## C

**CC8011** 205  
**CC8021** 205  
**CC8025** 205  
**CC8026** 205  
**CC8030** 205  
**CC8040** 205



# Index

**CC8041** 205  
**CC8050** 205  
**CC8050V90** 205  
**CC8050V120** 205  
**CC8060** 205  
**CC8060R** 205  
**CC8070** 205  
**CC8210** 205  
**CC8211** 205  
**CC8220** 205  
**CC8221** 205  
**CCAZ1050** 204  
**CCBO0801** 110, 190, 191, 194, 201, 204, 292  
**CCBO0802** 186, 187, 188, 189, 197, 198, 204  
**CCBO0803** 190, 192, 204  
**CCBUE121812** 338  
**CCBUE121912** 338  
**CCBUE162616** 338  
**CCBUE1218512** 338  
**CCBX0802** 204, 337  
**CCBXM4** 204, 337  
**CCBXS** 204  
**CCD004** 186, 187, 188, 189, 191, 192, 193, 197, 198, 201  
**CCD005** 190, 337  
**CCD007** 190  
**CCD010** 337  
**CCHMR** 51, 64, 65, 66, 67, 68, 69, 70, 73, 106, 107, 188, 189, 191, 192, 193, 194, 195, 205, 223, 224, 225, 205, 226  
**CCPD** 106, 205  
**CCPDR** 64, 73, 106, 188, 189, 191, 192, 194, 195, 205  
**CCPF12ALU** 338  
**CCPF16ALU** 338  
**CCU15026** 204  
**CCU15027** 204  
**CCU15080** 204  
**CCU15081** 204  
**CCU15082** 204  
**CCU15083** 204  
**CCU20026** 204  
**CCU20027** 204  
**CCU20080** 204  
**CCU20081** 204  
**CCU20082** 204  
**CCU20083** 204  
**CCU25026** 204  
**CCU25027** 204  
**CCU25080** 204  
**CCU25081** 204  
**CCU25082** 204  
**CCU25083** 204  
**CCU27580** 204  
**CCU27581** 204  
**CCU27582** 204  
**CCU27583** 204  
**CCU30026** 204  
**CCU30027** 204  
**CCU30039** 204  
**CCU30080** 204  
**CCU30081** 204  
**CCU32526** 204  
**CCU32527** 204  
**CCU35039** 204  
**CCU35080** 204  
**CCU40039** 204  
**CCU40080** 204  
**CCU45039** 204  
**CCU45080** 204

## D

**DS0402-90°** 337  
**DSE0402-60°** 106, 205  
**DSE0402-90°** 337  
**DSE0402-BS** 337

## E

**ER32** 98  
**ER-033400** 300  
**ER-033402** 299  
**ER-033800** 299, 300  
**ER-036800** 300  
**ER-036802** 299  
**ER-038000** 299, 300  
**ER-039200** 299, 300  
**ER-039201** 299, 300  
**EROWA ITS-Palette** 119  
**EROWA MTS** 297

## F

**FA1240** 59, 107, 337  
**FA1260** 107, 337  
**FA1280** 337  
**FA12100** 337  
**FAD12018** 337  
**FAD12023** 337  
**FAD12040** 337  
**FAUM2070** 336  
**FAUM2070S** 336  
**FAUM2070US** 336  
**FED0318** 71  
**FED0418** 60, 62, 186, 187, 197  
**FED0618** 63, 64, 65, 66, 67, 68, 69, 70, 72, 73, 110, 188, 189, 190, 191, 192, 193, 194, 195, 197, 198, 201, 223, 224, 225, 226, 227, 228, 229, 230, 231  
**FED02813** 182, 183, 184, 185  
**FED03018** 61, 178, 179, 180, 181

## G

**GEWST6L14** 196  
**GPL160MATS** 56, 57  
**GPL30040** 274  
**GPL40040** 274  
**GPL45040** 274  
**GPL50040** 274  
**GPL63040** 274  
**GPL80040** 274  
**GPL50040040** 274

## I

**ISL10** 102, 340  
**ISL14** 340

## K

**KALST aptoCLAMP** 340  
**KALST powerCLAMP** 340

## M

**M3X6ISO4762** 61, 180, 181  
**M3X8ISO4762** 106, 205  
**M3X10ISO4762** 61, 180, 335, 181  
**M3X25ISO4762** 197, 198, 201  
**M4X6ISO4027** 99

**M4X8ISO4762** 159  
**M4X10ISO4762** 322  
**M5X8ISO4762** 111, 112, 190  
**M5X8ISO7380** 157, 158, 159, 186, 187, 188, 189, 191, 192, 193, 197, 198, 201  
**M5X10DIN6912** 182, 183, 184, 185  
**M5X10DIN7991** 200  
**M5X10ISO4762** 60, 61, 62, 63, 64, 65, 66, 67, 68, 69, 70, 71, 72, 73, 74, 75, 76, 77, 78, 79, 81, 82, 83, 85, 86, 87, 88, 89, 90, 91, 106  
**M5X10ISO7380-1** 223, 224, 225, 226, 227, 228, 229, 230, 231  
**M5X12ISO4762** 178, 179, 180, 205, 205  
**M5X12ISO7380** 106, 186, 187, 188, 189, 190, 191, 192, 193, 197, 198, 201, 205  
**M5X14ISO4762** 60, 62, 63, 64, 65, 66, 67, 68, 69, 70, 73, 74, 75, 76, 77, 78, 79, 80, 81, 82, 83, 182, 183, 184, 185, 336  
**M5X14ISO7380-1** 223, 224, 225, 226, 227  
**M5X16DIN912** 92, 122, 152  
**M5X16DIN7991** 106  
**M5X16ISO4026** 73  
**M5X16ISO4762** 68, 72, 141, 175, 176, 178  
**M5X16ISO7380** 190  
**M5X18ISO4762** 107, 205  
**M5X20BN1362** 96  
**M5X20BN1392** 108  
**M5X20ISO4762** 106, 107, 111, 205, 205  
**M5X22ISO4762** 112  
**M5X25ISO4762** 205  
**M5X30ISO4762** 106  
**M5X85DIN912** 109, 110, 112  
**M6X8ISO7380** 47, 48, 50, 51, 60, 61, 62, 63, 64, 65, 66, 67, 68, 69, 70, 71, 72, 73, 74, 75, 76, 77, 78, 79, 80, 81, 82, 83, 85, 86, 87, 88, 89, 90, 91, 92, 93, 94, 95, 96, 97, 98, 99, 100, 101, 102, 105, 108, 146, 150, 151, 318, 319  
**M6X10ISO4762** 141, 142, 144, 146, 150, 151  
**M6X10ISO7380** 123, 124, 148  
**M6X12BN5128** 335  
**M6X12DIN912** 43  
**M6X12ISO4762** 43, 322, 337  
**M6X14ISO10642** 104  
**M6X16ISO4762** 61, 71, 181, 337  
**M6X16ISO7380** 126  
**M6X18DIN912** 160  
**M6X18ISO4762** 322  
**M6X20ISO4762** 60, 186, 337  
**M6X25ISO4762** 177, 322  
**M6X35ISO4762** 157, 317, 336  
**M6X40ISO4762** 158  
**M6X45ISO4762** 97, 314, 315, 316  
**M6X60ISO4762** 158  
**M8X16ISO4762** 157, 158  
**M8X20ISO4762** 62, 63, 64, 72, 73, 186, 187, 188, 189, 190, 191, 192, 194, 195, 197, 198, 199, 201, 189  
**M8x20ISO4762NQ** 338  
**M8X22DIN7991** 175, 176  
**M8X25ISO4762** 46, 200, 202, 203, 337

**M8X28ISO4762** 74, 75, 76, 78, 80, 84  
**M8X30ISO4762** 76, 77, 79, 81, 84, 188, 192, 199, 200, 203, 227  
**M8X35DIN912** 190  
**M8X35ISO4762** 82, 83, 191, 194, 201  
**M8X40DIN912** 136  
**M8X50ISO4762** 97  
**M8X55DIN912** 190  
**M8X55ISO4762** 97, 192  
**M10X12ISO4027** 314, 315, 316, 317, 318, 323  
**M10X22ISO4762** 108  
**M10X25ISO4762** 65, 66, 67, 68, 69, 70, 193, 223, 224, 225, 226  
**M10x25ISO4762NQ** 338  
**M10X30ISO4762** 96  
**M12X16ISO4762** 289  
**M12X20DIN6912** 119  
**M12X20ISO4762** 136  
**M12X25DIN7984** 275  
**M12X30DIN7984** 232  
**M12X30ISO4762** 228, 229, 230, 231  
**M12X35ISO4762** 118, 119, 193, 271  
**M12X40ISO4762** 46, 50, 54  
**M12X45ISO4762** 43, 46  
**M12X50ISO4762** 228, 229, 230, 231  
**M16X45ISO4762** 223, 224, 225, 227, 228, 229, 230, 231  
**M16X55ISO4762** 227, 231  
**M16X65ISO4762** 228, 229, 230  
**M16X70ISO4762** 223, 224, 225, 226, 228, 229, 230  
**MA248650R50** 269  
**MA248655R50** 269  
**MA248660R50** 269  
**MA248665R50** 269  
**MA301265R50-8-2** 270  
**MA301270R50-8-2** 270  
**MA301275R50-8-2** 270  
**MABD501550** 275  
**MABD502050** 275  
**MABD502550** 275  
**MABD503050** 275  
**MAND38-14PRG** 92, 176  
**MAND38-14PRG6** 176  
**MAND58-14PRG** 92, 141, 154, 175  
**MAND58-14PRG6** 175  
**MANF38-14F25** 176  
**MANF38-14RF** 176  
**MANF38-14W25** 176  
**MANF58-14F25** 176  
**MANF58-14RF** 176  
**MANF58-14W25** 140, 154, 176  
**MCD004** 180, 181  
**MCU11037** 61, 180, 181, 204  
**MCU15037** 61, 180, 181, 204  
**MCU18037** 61, 180, 181, 204  
**MCU20037** 61, 180, 181, 204  
**MCU22537** 61, 180, 181, 204  
**MCZ40L30** 115, 116, 117  
**MCZ40L30PRG13** 116, 118, 119, 120, 204  
**MCZ40L30PRG22** 116, 118, 119, 120  
**MCZ40L30PRG31** 116, 118, 119, 120  
**MCZ40L30W6** 118, 119, 120  
**MCZ40L30W10** 118, 119, 120





# Index

- MCZ40L30W20** 116, 118, 119, 120  
**MCZ40L30W30** 118, 119  
**MCZ100L50** 127, 130, 132, 133, 134, 135, 136, 126  
**MK200970R50** 251  
**MK300950R50** 251  
**MK300955R50** 251  
**MK300960R50** 251  
**MK300965R50** 251  
**MK300970R50** 251  
**MK300975R50** 251  
**MK301850R50** 253  
**MK301855R50** 253  
**MK301860R50** 253  
**MK301865R50** 253  
**MK301870R50** 253  
**MK301875R50** 253  
**MK321075R100** 254  
**MK321080R100** 254  
**MK321085R100** 254  
**MK321090R100** 254  
**MK321095R100** 254  
**MK321875R100** 254  
**MK321880R100** 254  
**MK321885R100** 254  
**MK321890R100** 254  
**MK321895R100** 254  
**MK350865R50** 252  
**MK350870R50** 252  
**MK350875R50** 252  
**MK350880R50** 252  
**MK350885R50** 252  
**MK350890R50** 252  
**MK350895R50** 252  
**MK351865R50** 255  
**MK351870R50** 255  
**MK351875R50** 255  
**MK351880R50** 255  
**MK351885R50** 255  
**MK351890R50** 255  
**MK351895R50** 255  
**MK401865R50** 256  
**MK401870R50** 256  
**MK401875R50** 256  
**MK401880R50** 256  
**MK401885R50** 256  
**MK401890R50** 256  
**MK401895R50** 256  
**MQ161630R50** 257  
**MQ161635R50** 257  
**MQ161640R50** 257  
**MQ161645R50** 257  
**MQ161650R50** 257  
**MQ202045R50** 258  
**MQ202050R50** 258  
**MQ202055R50** 258  
**MQ202060R50** 258  
**MQ202065R50** 258  
**MQ202070R50** 258  
**MQ242450R50** 258  
**MQ242455R50** 258  
**MQ242460R50** 258  
**MQ242465R50** 258  
**MQ252560R50** 259  
**MQ252565R50** 259  
**MQ252570R50** 259  
**MQ252575R50** 259  
**MQ252580R50** 259  
**MQ303050R50** 259  
**MQ303055R50** 259  
**MQ303060R50** 259  
**MQ303065R50** 259  
**MQ303070R50** 259  
**MQ303075R50** 259  
**MQ353565R50** 260  
**MQ353570R50** 260  
**MQ353575R50** 260  
**MQ353580R50** 260  
**MQ353585R50** 260  
**MQ353590R50** 260  
**MQ353595R50** 260  
**MQ404065R50** 260  
**MQ404070R50** 260  
**MQ404075R50** 260  
**MQ404080R50** 260  
**MQ404085R50** 260  
**MQ404090R50** 260  
**MQ404095R50** 260  
**MQ424275R40** 261  
**MQ424280R40** 261  
**MQ424285R40** 261  
**MQ424290R40** 261  
**MQ424295R40** 261  
**MR1F30N23-07** 178  
**MR301550R50** 262  
**MR301555R50** 262  
**MR301560R50** 262  
**MR301565R50** 262  
**MR401245R50** 262  
**MR401250R50** 262  
**MR401255R50** 262  
**MR401260R50** 262  
**MR402050R50** 263  
**MR402055R50** 263  
**MR402060R50** 263  
**MR402065R50** 263  
**MR402070R50** 263  
**MR402075R50** 263  
**MR502060R50-2** 264  
**MR502060R50-4** 264  
**MR502065R50-2** 264  
**MR502065R50-4** 264  
**MR502070R50-2** 264  
**MR502070R50-4** 264  
**MR502075R50-2** 264  
**MR502075R50-4** 264  
**MR502080R50-2** 264  
**MR502080R50-4** 264  
**MR502085R50-2** 264  
**MR502085R50-4** 264  
**MR502090R50-2** 264  
**MR502090R50-4** 264  
**MR502095R50-2** 264  
**MR502095R50-4** 264  
**MR602060R50-2** 265  
**MR602060R50-4** 265  
**MR602065R50-2** 265  
**MR602065R50-4** 265  
**MR602070R50-2** 265  
**MR602070R50-4** 265  
**MR602075R50-2** 265  
**MR602075R50-4** 265  
**MR602080R50-2** 265  
**MR602080R50-4** 265  
**MR602085R50-2** 265  
**MR602085R50-4** 265  
**MR602090R50-2** 265  
**MR602090R50-4** 265  
**MR602095R50-2** 265  
**MR602095R50-4** 265  
**MR633075R40** 266  
**MR633080R40** 266  
**MR633090R40** 266  
**MR633095R40** 266  
**MR701550R50** 267  
**MR701555R50** 267  
**MR701560R50** 267  
**MR701565R50** 267  
**MR701570R50** 267  
**MR701575R50** 267  
**MS1F22N40-07** 179  
**MS1F24N22-07** 180  
**MS1F25N25-13** 181  
**MS1F35L14-152** 196  
**MS1F35N14-01** 182  
**MS1F35N22-01** 182  
**MS1F58L14W251** 176  
**MS1P58L14PRG15** 175  
**MS1R24N22-07** 180  
**MS1R25N25-13** 181  
**MS1R35L14-152** 196  
**MS1R35N14-01** 182  
**MS2F58L14W251** 176  
**MS2F60N14-01** 184  
**MS2P58L14PRG15** 175  
**MS2X35N23-01** 183  
**MS3F85N14-01** 185  
**MS50** 117, 130, 177, 180, 182, 183, 184, 185, 196, 338  
**MS60** 102, 181, 338  
**MS321960R50** 268  
**MS321965R50** 268  
**MS321966R80** 268  
**MS321970R50** 268  
**MS321975R50** 268  
**MS321980R50** 268  
**MS402366R40** 268  
**MS402366R50** 268  
**MS402395R40** 268  
**MS402395R50** 268  
**MSK15W45** 196  
**MUB2817-H85** 271  
**MUB2817-H100** 271  
**MUB2817-H125** 271  
**MV1F20L35BV1** 101, 177  
**NR701560R50** 267  
**NR701565R50** 267  
**NR701570R50** 267  
**NR701575R50** 267  
**MS1F22N40-07** 179  
**MS1F24N22-07** 180  
**MS1F25N25-13** 181  
**MS1F35L14-152** 196  
**MS1F35N14-01** 182  
**MS1F35N22-01** 182  
**MS1F58L14W251** 176  
**MS1P58L14PRG15** 175  
**MS1R24N22-07** 180  
**MS1R25N25-13** 181  
**MS1R35L14-152** 196  
**MS1R35N14-01** 182  
**MS2F58L14W251** 176  
**MS2F60N14-01** 184  
**MS2P58L14PRG15** 175  
**MS2X35N23-01** 183  
**MS3F85N14-01** 185  
**MS50** 117, 130, 177, 180, 182, 183, 184, 185, 196, 338  
**MS60** 102, 181, 338  
**MS321960R50** 268  
**MS321965R50** 268  
**MS321966R80** 268  
**MS321970R50** 268  
**MS321975R50** 268  
**MS321980R50** 268  
**MS402366R40** 268  
**MS402366R50** 268  
**MS402395R40** 268  
**MS402395R50** 268  
**MSK15W45** 196  
**MUB2817-H85** 271  
**MUB2817-H100** 271  
**MUB2817-H125** 271  
**MV1F20L35BV1** 101, 177  
**NT2012** 338  
**NT2014** 338  
**NT2016** 338  
**NT2018** 338  
**NT2022** 338  
**NT2024** 338  
**NUSS1/2"8MM** 340  
**NUSS1/2"10MM** 340  
**NUSS1/2"14MM** 340  
**NUSS1/2"14MML** 340  
**NUSS1/4"4.5MM** 340  
**NUSS1/4"4MM** 340  
**NUSS1/4"5.5MM** 340  
**NUSS1/4"5MM** 340  
**NUSS1/4"6MM** 340  
**NUSS1/4"8MM** 340  
**Nuss 1/4 - sw 4,5** 116, 117, 118, 119, 122, 123, 124  
**Nuss 1/4 - sw 5,5** 123, 124  
**NUSS3/8"5MM** 340  
**NUSS3/8"5MML** 340  
**NUSS3/8"5MMLK** 340  
**NUSS3/8"6MM** 340  
**NUSS3/8"6MML** 340  
**NUSS3/8"6MMLK** 340  
**NUSS3/8"8MM** 340  
**NUSS3/8"8MML** 340  
**NUSS3/8"8MMLK** 340  
**NUSS3/8"10MM** 340  
**NUSS3/8"10MML** 340  
**NUSS3/8"10MMLK** 340  
**NUSS3/8"TX30E14** 126, 127, 136, 141, 142, 144, 146, 150, 151, 287, 288, 289, 126, 287  
**O**  
**OP92BUE23** 291  
**OP92BUE23ID** 291  
**OPA1ID160** 293  
**OPA1ID160R50** 293  
**OPA1ID200** 293  
**OPA1ID200R50** 293  
**OPA1IDPCBD178** 293  
**OPA4Q200** 296  
**OPA4Q200R50** 296  
**OPA182H63-RS** 293  
**OPA2200** 294  
**OPA2200R50** 294  
**OPA3200** 295  
**OPA3200R50** 295  
**OPANS-8** 301  
**OPB1ID** 293  
**OPB4Q200** 296  
**OPB2160** 294  
**OPB2200** 294  
**OPB2200R50** 294  
**OPB2200R50ID-1** 294  
**OPB2200R50ID-2** 294  
**OPB3200** 295  
**OPB3200ID-1** 295  
**OPBM4Q100R50** 283, 286, 287, 288, 289  
**OPBM4Q100R200** 287  
**OPEGB** 292  
**OPEGBID** 292  
**OPM3X80L75** 286, 290  
**OPM3X100L82** 286, 290  
**OPM3X125L88** 286, 290  
**OPM25-15R50H28** 286  
**OPM25-15RH40** 286  
**OPMAD** 286  
**OPMAW** 289  
**OPMB12M12** 283, 287, 289  
**OPMB12M12S** 289  
**OPMB12M12U** 289  
**OPMB18M12** 119, 288, 289, 290  
**OPMB18M12S** 289  
**OPMB18M12U** 289, 290  
**OPMBL** 289  
**OPPAD** 301  
**OPPD** 301  
**OPRV** 301  
**OPSKU** 301  
**OPST-NI** 301  
**OPUB150H44** 286, 288  
**P**  
**PA5X19-49F** 85, 143, 161  
**PA5X19-49R** 85, 161  
**PA5X26-49F** 85  
**PA5X26-49R** 85  
**PA5X34-49F** 85, 143  
**PA5X34-49R** 85  
**PA5X43-49F** 89  
**PA5X43-49R** 89  
**PA5X48-49F** 89, 161  
**PA5X48-49R** 89, 161  
**PA5X49-49F** 161  
**PA5X49-49R** 161  
**PA5X94-49F** 89  
**PA5X94-49R** 89, 271  
**PA5X125-49F** 89, 143, 161



# Index

- PA5X125-49R 89, 161
- PAND19-49 85
- PAND25-44 86, 143
- PAND26-49 85
- PAND34-49 85, 143
- PAND43-49 89, 143
- PAND48-34 58, 87, 143
- PAND48-34PRF-A1 58, 90
- PAND48-34PRG-A1 90, 143
- PAND48-49 58, 89
- PAND48-49PRF-A1 58, 90
- PAND48-49PRG-A1 90
- PAND48-75 87, 143
- PAND58-34 87
- PAND58-49 87
- PAND60-19 157, 158, 159
- PAND60-20.5UWB 159
- PAND61-34 87
- PAND68-34 88, 143
- PAND78-34 58, 88
- PAND78-34UPRG 92, 144, 146
- PAND78-34X50UPRG 92, 144
- PAND78-49 58, 88, 143
- PAND78-49UPRG 92
- PAND94-34 58, 88
- PAND94-34PRF-A1 58, 90
- PAND94-34PRG-A1 90, 161
- PAND94-34PRGV 91
- PAND94-44 86
- PAND94-49 58, 89
- PAND94-49PRF-A1 58, 90
- PAND94-49PRF-A1P 148
- PAND94-49PRG-A1 90, 115, 139, 143, 148
- PAND94-49PRGV 91
- PAND120-49UPRG 92
- PAND125-34PRG-A1 91
- PAND125-49 89, 143
- PAND125-49PRG-A1 90
- PAND150-34PRG-A1 91
- PB2212L/6 202, 203
- PC2280L40PRG62 124
- PC48-34PRG 107
- PC48-49PRG 107
- PC94-34PRG 107
- PC94-49PRG 107
- PC4349 106
- PC4349DS 106
- PC4834 106, 107
- PC4834DS 106
- PC4834N 111
- PC4834RF 107
- PC4849 107
- PC4849DS 106
- PC4849RF 107
- PC9434 106
- PC9434DS 106
- PC9434N 111
- PC9434RF 107
- PC9434V120 106
- PC9449DS 106
- PC9449RF 107
- PC9449V120 106
- PC9460 106
- PC9460R 106
- PC12549 106
- PC12549DS 106
- PC943425W 106
- PC943430W 106
- PC944930W 106
- PC1254930W 106
- PCAZM3 338
- PCB250Q90H35 47
- PCB850SET 46
- PCB900SET 46
- PCB950SET 46
- PCB1000SET 46
- PCB6090 42
- PCB25200 42, 50
- PCB25300 42, 50
- PCB50207W25 52
- PCB50320 41, 42
- PCB50320H60 41, 43
- PCB50320H80 41, 44
- PCB50350H80 44
- PCB50400H80 44
- PCB50450H80 44
- PCB50500H80 44
- PCB50550H80 44
- PCB50600H80 44
- PCB50650H80 44
- PCB50700H80 44
- PCB50750H80 44
- PCB100350H60 43
- PCB100400H60 43
- PCB100500H60 43
- PCB100600H60 43
- PCB100650H60 43
- PCB100690H60 43
- PCB100850H60 43
- PCB2550250 42, 58
- PCB2550250-OPM 286
- PCB4050125 42
- PCB4050125H80 44
- PCB4050220W2 42
- PCB4050250KP 46
- PCB4050350 42, 58
- PCB4050400 42, 58
- PCB4050400KP 46
- PCB4050450 42, 58
- PCB4050450KP 46
- PCB4050500 42, 58
- PCB4050500KP 46
- PCB4050550 42, 58
- PCB4050600 42, 58
- PCB4050650 42, 58
- PCB4050650KP 46
- PCB4050700 42, 58
- PCB4050700KP 46
- PCB4050750 42, 58
- PCB4050800 42, 58
- PCBP69SET 46, 244
- PCBR40 43
- PCD005 60, 62, 63, 64, 65, 66, 67, 68, 69, 70, 73, 74, 75, 76, 77, 78, 79, 80, 81, 82, 83, 223, 224, 225, 226, 227
- PCD008 68, 72, 111
- PCFM58 110
- PCFM3322 110
- PCFM5822 110
- PCFX30 109
- PCFX35 109
- PCFX50 109
- PCFX70 109
- PCGL15050 53
- PCGU2028 108
- PCGU2030 47, 61, 71, 93, 146, 151
- PCGU2030LB 108
- PCGU2049 48, 50, 51, 60, 62, 63, 64, 65, 66, 67, 68, 69, 70, 72, 73, 85, 86, 87, 88, 89, 90, 91, 92, 93, 94, 95, 96, 100, 101, 102, 105, 124, 148, 150, 151, 318, 319
- PCGU2049F 104
- PCGU2059 74, 75, 76, 77, 78, 79, 80, 81, 82, 83, 91, 94, 97, 98
- PCL4349N 108
- PCL4834N 108
- PCL9434N 108
- PCL9449N 108
- PCL12549N 108
- PCMAS350 335
- PCMAS400 335
- PCMAS450 335
- PCMAS500 335
- PCMAS500ML 335
- PCMAS550 335
- PCMAS600 335
- PCMAS600ML 335
- PCMAS650 335
- PCMAS700 335
- PCMAS700ML 335
- PCMAS750 335
- PCMAS800 335
- PCMAS800ML 335
- PCMB4 340
- PCMB50300H175 45
- PCMB50400H175 45
- PCMB50500H175 45
- PCMB50600H175 45
- PCMT150-700 54
- PCMT150-750 54
- PCMT150-800 54
- PCMT150-850 54
- PCPF16L6 46, 338
- PCPF16L18 46, 338
- PCS14 47, 48, 50, 51, 60, 61, 62, 63, 64, 65, 66, 67, 68, 69, 70, 71, 72, 73, 74, 75, 76, 77, 78, 79, 80, 81, 82, 83, 85, 86, 87, 88, 89, 90, 91, 92, 93, 94, 95, 96, 97, 98, 99, 100, 101, 102, 104, 105, 123, 124, 126, 146, 148, 150, 151, 318, 319
- PCS14M107SET 126, 127
- PCS16TR140SET 141, 142, 144, 150
- PCS16TR160SET 141, 142, 144, 150
- PCS16TR180SET 141, 142, 144, 150
- PCS16TR200SET 141, 142, 144, 146, 150, 151
- PCSET18-250A 58
- PCSET18-320B 58
- PCSET18-350A 58
- PCSET18-400A 58
- PCSET18-400B 58
- PCSET18-450A 58
- PCSET18-500A 58
- PCSET18-500B 58
- PCSET18-550A 58
- PCSET18-600A 58
- PCSET18-600B 58
- PCSET18-650A 58
- PCSET18-650B 58
- PCSET18-690B 58
- PCSET18-850B 58
- PCSET18-L1 59
- PCSET18-L2 59
- PCSET18-L3 59
- PCSET18-L4 59
- PCSET18-L5 59
- PCSET18-L6 59
- PCSET18-L7 59
- PCSET18-L8 59
- PCSET18-L9 59
- PCSET18-L11 59
- PCSET18-L12 59
- PCSET18-L13 59
- PCSET18-L14 59
- PCSET18-L15 59
- PCSET18-L16 59
- PCSET18-L17 59
- PCSET18-N1 58, 59
- PCSET18-N2 59
- PCSET18-N3 59
- PCSET18-N4 59
- PCSET18-N5 59
- PCSET18-N6 59
- PCSET18-N7 59
- PCSET18-N8 59
- PCSET18-N9 59
- PCSET18220W2-OPM 286
- PCSET18250-OPM 286
- PCSP10B 109, 110, 112
- PCSP10G 109, 110, 112
- PCSP10SET 110
- PCSP30L 47, 61, 93, 98, 146, 151
- PCSP30R 47, 61, 93, 98, 146, 151
- PCSP40L 71
- PCSP40R 71
- PCSP50L 65, 67, 72, 86, 91, 92, 93, 94, 95, 96, 104, 318
- PCSP50LF 68
- PCSP50R 65, 67, 72, 86, 91, 92, 93, 94, 95, 96, 104, 318
- PCSP50RF 68
- PCSP60L 48, 50, 51, 60, 62, 63, 64, 65, 66, 67, 68, 69, 70, 73, 74, 75, 76, 77, 78, 79, 80, 81, 82, 83, 85, 87, 88, 89, 90, 91, 92, 93, 94, 96, 97, 98, 99, 100, 101, 102, 105, 123, 124, 126, 148, 151, 319
- PCSP60LG 150
- PCSP60R 48, 50, 51, 60, 62, 63, 64, 65, 66, 67, 68, 69, 70, 73, 74, 75, 76, 77, 78, 79, 80, 81, 82, 83, 85, 87, 88, 89, 90, 91, 92, 93, 94, 96, 97, 98, 99, 100, 101, 102, 105, 123, 124, 126, 148, 151, 319
- PCSP60RG 150
- PCT110-250MATS 56, 57
- PCT110-300 54
- PCT110-300MATS 56, 57
- PCT110-350 54
- PCT110-400 54
- PCT110-450 54
- PCT110-500 54
- PCT110-550 54
- PCT110-600 54
- PCT110-650 54
- PCT110-700 54
- PCT155-290-3MATS 56, 57
- PCT7280232MATS 56, 57
- PCU10093 112
- PCU14093 112, 232
- PCU20018 112
- PCU20025 112
- PCU20033 112
- PCU20042 112
- PCU20047 112
- PCU20057 112
- PCU20060 112
- PCU20067 112
- PCU20077 112
- PCU20077B10 112
- PCU20077B10-W 112
- PCU20093 112, 232
- PCU20124 112, 232
- PCU24018 112
- PCU24025 112
- PCU24033 112
- PCU24042 112



# Index

- PCU24047 112
- PCU24057 112
- PCU24060 112
- PCU24067 112
- PCU24077 112
- PCU24093 112, 232
- PCU24093B10 112
- PCU24093B10-W 112
- PCU24124 112, 232
- PCU29018 112
- PCU29025 112
- PCU29033 112
- PCU29042 112
- PCU29047 59, 112
- PCU29057 112
- PCU29060 112
- PCU29067 112
- PCU29077 112
- PCU29093 59, 112, 232
- PCU29093B10 112
- PCU29124 112, 232
- PCU31018 112
- PCU31025 112
- PCU31033 112
- PCU31042 112
- PCU31047 112
- PCU31057 112
- PCU31060 112
- PCU31067 112
- PCU31077 112
- PCU31093 112, 232
- PCU31093B10 112
- PCU31124 112, 232
- PCU34018 112
- PCU34025 112
- PCU34033 112
- PCU34042 112
- PCU34047 112
- PCU34077 112
- PCU34093 112, 232
- PCU34093B10 112
- PCU34124 112, 232
- PCU39018 112
- PCU39025 112
- PCU39033 112
- PCU39042 112
- PCU39047 112
- PCU39077 59, 112
- PCU39093 112, 232
- PCU39093B10 112
- PCU39093B10-W 112
- PCU39124 112, 232
- PCU44018 112
- PCU44025 112
- PCU44033 112
- PCU44042 112
- PCU44047 112
- PCU44077 112
- PCU44093 112, 232
- PCU44093B10 112
- PCU44093B10-W 112
- PCU44124 112, 232
- PCU46033 112
- PCU46042 112
- PCU46047 112
- PCU46093 112, 232
- PCU46093B10 112
- PCU46093B10-W 112
- PCU46124 112
- PCU46518 112
- PCU46525 112
- PCU46533 112
- PCU47042 112
- PCU47093 112
- PCUB60-70-130 51
- PCUB60-130 48
- PCUB100-200 48
- PCUB100-300 48
- PCUB115-200-R25 50
- PCUB115-300-R25 50
- PCUH2594 112
- PCUM1409308 111
- PCUM2009308 111
- PCUM2409308 111
- PCUM2909308 111
- PCUM3109308 111
- PCUM3409308 111
- PCUM3909308 111
- PCUM4409308 111
- PCUM4609308 111
- PCUSR14 76, 77, 79, 81, 82, 83, 84, 200
- PCUSR16 74, 75, 76, 78, 80, 84
- PCWB252594 73
- PCWB252594RF 73
- PCWB262694 73
- PCZ80L40PRG62 123
- PCZ100L50 103, 126, 130, 132
- PCZB7021PRF 149, 152
- PCZB7023PRG 149, 152
- PCZB8050UPRG 149, 150, 151, 152
- PCZB8060R34 149, 152
- PCZB8060R40ALU 152
- PCZB10060R50 152
- PCZB10060R50ST 152
- PCZB12060R34 149, 152
- PCZS2439-ID-SET 126, 127
- PCZS2439L 126, 127
- PCZS2439R 126, 127
- PF-SET 84
- PR94-39-50 94
- PR94-39-50SET 94
- PR94-49 94
- PR94-49SET 94, 143
- PR125-49 94
- PR125-49ALU 94
- PR125-49SET 94
- PR125-49SETALU 94
- PR150-49 94
- PR150-49SET 94
- PRG1003M8 129, 152, 337
- PRS50L78ST 96
- PRS70L78ST 96, 143
- PS1F19N49-20 60
- PS1F20L35BV1 101
- PS1F20L35BV1NS 101
- PS1F25N44-13 61
- PS1F26N49-26 62
- PS1F34N49-45 63
- PS1F43N49-60 51, 64
- PS1F43N62-60 64
- PS1F48L34-105 76
- PS1F48L49-105 79
- PS1F48N34-80 65
- PS1F48N49-80 66
- PS1F58N34-80 65
- PS1F68N34-80 65
- PS1F78L34-105 77
- PS1F78L49-105 77
- PS1F78N34-80 67
- PS1F78N49-80 67
- PS1F78N49-90 69
- PS1F94L34-105 81
- PS1F94L49-105 81
- PS1F94N34-80 67
- PS1F94N34-90 68
- PS1F94N49-90 68
- PS1F125N49-95 70
- PS1F-KLD1 100
- PS1F-KLD1NS 100
- PS1P48L34-105 74
- PS1P48L49-105 74
- PS1P94L34-105 75
- PS1P94L49-105 75
- PS1P694L34-105 75
- PS1PF48L34-105 74
- PS1PF48L49-105 74
- PS1PF94L34-105 75
- PS1PF94L49-105 75
- PS1PV48L34-105 76
- PS1PV94L34-105 78
- PS1PV94L49-105 78
- PS1R19N49-20 60
- PS1R25N44-13 61
- PS1R26N49-26 62
- PS1R34N49-45 63
- PS1R43N49-60 64
- PS1R43N49-B60 54, 56
- PS1R43N62-60 64
- PS1R48L34-105 76, 77
- PS1R48L49-105 79
- PS1R48L49-105H20 82
- PS1R48N34-80 65
- PS1R48N49-80 66
- PS1R48N75-80 66
- PS1R58N34-80 65
- PS1R58N49-80 65
- PS1R68N34-80 65
- PS1R78L34-105 77
- PS1R78L49-105 77
- PS1R78N34-80 67
- PS1R78N49-80 67
- PS1R78N49-90 69
- PS1R94L34-105 81
- PS1R94L49-105 81
- PS1R94L49-105H20 82
- PS1R94N34-80 67
- PS1R94N34-90 68
- PS1R94N34-B80 54, 56
- PS1R94N49-90 68
- PS1R94N49-B90 54, 56
- PS1R125L49-105H20 83
- PS1R125N49-95 70
- PS1R125N49-B95 54, 56
- PS1X50L78ST 96
- PS1X50N62-ER32 98
- PS1X50N100-ER32 98
- PS1X63N100-ER40 98
- PS1X68N80-W20 99
- PS1X70L78ST 96
- PS1X80L31-VAC 319, 321
- PS1X100-65ER-036345 104
- PS1X150L60-250MAG11 102
- PS1X150L60-VAC 103, 318, 321
- PS2F61N34-45 72
- PS2G94N44-13 71
- PS2R61N34-45 72
- PS2X94N49-60 73
- PS3X80L75BSET 97
- PS3X100L82BSET 97
- PS3X125L87BSET 97
- PS5X19N49-20 60
- PS5X26N49-26 62
- PS5X34N49-45 63
- PS5X43N49-60 64
- PS5X48L34-105 80
- PS5X48L49-105 79
- PS5X48N49-80 66
- PS5X94L49-105 81
- PS5X94N49-90 68
- PS5X125N49-95 70
- PSH1X94L49-310 105
- PT-F61-25X30 93
- PT-F61-25X50 93
- PT-F61-25X60 93
- PT-F80-30X30NS 93
- PT-F80-30X60 93, 143
- PT-F80-30X60NS 93
- PT-F132-34RD 94
- PT-F132-34RDSET 94
- PTX80-30 97
- PTX100-29 104
- PTX100-30 97
- PTX125-29 97
- PTX160-57S 95
- PTX160-77S 95

## Q

- QSG1/4-8 319, 323
- QSL-G1/4-8 323
- QST-G1/4-8 323

## R

- RD16M12 338
- RD16M1612M12 338
- RD18M1612M12 338
- RP9431SET 339
- RPD504-R50 274
- RPQ50504-R50 274

## S

- SET18ZSP40L38-2 156
- SET18ZSP125L85-1 157
- SET18ZSP125L110-2 158
- SFED6W90 196
- SL0 340
- SL1 340
- SL3 340
- SM1135M6X8 322, 338
- SM1135M06X10 338
- SM1135M08X10 338
- SM1135M08X12 338
- SM1135M08X14 338
- SM1135M10X12 338
- SM1135M10X14 338
- SM1135M12X14 338
- SM1135M12X16 338
- SM1135M12X18 338
- SM1135M12X20 338
- SM1135M12X22 338
- SM1135M14X16 338
- SM1135M14X18 338
- SM1135M16X18 338
- SM1135M16X20 338
- SM1135M18X20 338
- SM1135M18X22 338
- SM1135M20X22 338
- SM1135M20X24 338
- SM1135M24X28 338
- SM1136-12 338
- SM1136-14 338
- SM1136-16 338
- SM1136-18 338
- SM1136-20 43, 338
- Smiley 339
- SMK24-24-42OPP200 272
- SMK30-17-42OPP200 272
- SMK301850R50 253
- SMK301855R50 253





# Index

SMK301860R50 253  
 SMK301865R50 253  
 SMK301870R50 253  
 SMK301875R50 253  
 SMK351865R50 255  
 SMK351870R50 255  
 SMK351875R50 255  
 SMK351880R50 255  
 SMK351885R50 255  
 SMK351890R50 255  
 SMK351895R50 255  
 SMUB2373H220 276  
 SMUB3373H220 276

## T

TB150091 144, 146  
 TB150092 144, 146  
 TB150998 123, 124  
 TB160379 134, 135, 286, 288, 289,  
 301  
 TB170051 142  
 TC10 339  
 TH130026 117  
 TK150FL160 53  
 TK150057 174  
 TKPC110-300 53  
 TKPC110-350 53  
 TKPC110-400 53  
 TKPC110-450 53  
 TKPC110-500 53  
 TKPC110-550 53  
 TKPC110-600 53  
 TKPC110-650 53  
 TN100668 326, 327  
 TN100682 323  
 TN100992 323  
 Triag Bit 339  
 Triag Bitburr 339  
 Triag Ei 340  
 Triva Bit 324  
 TS150487 323  
 TWADAPT10 337  
 TWADAPT12 337  
 TWADAPT14 337  
 TWADAPT16 337

TWADAPT18 337  
 TWADAPT20 337  
 TWADAPT22 337  
 TWPAS1227 338  
 TWPAS1232 195, 338  
 TWPAS1240 46, 50, 54, 179, 287,  
 287  
 TWPAS1250 338  
 TWPAS16055 338

## U

UA2-260 321, 322  
 UA3-360 321, 322  
 UA3-560 321, 322  
 UA3-660 321, 322  
 UA0770 321, 322  
 UA182540 318, 321, 322  
 UB1-OIL 325  
 UB5AXMCZ40-35SET4 118  
 UB5AXMCZ40-35SET8 118  
 UB5AXMCZ40-45SET4 119  
 UB5AXMCZ40-45SET8 119  
 UB5AXMCZ40-45SET8-ER 119  
 UB5AXMCZ4045SET8-OPBM 286  
 UB5AXMCZ4045SET8-OPMB 119  
 UB5AXSET18-3 122  
 UBA106110250 321, 325  
 UBA106230300 321, 325  
 UBA118230600 325  
 UBA306400250 325  
 UBA318400550 321, 325  
 UBS5045 326  
 UBT40 325  
 UF15030050R50 317, 321  
 UF20030050R50 316, 321  
 UF30060050R50 315, 321  
 UF50050050R50 314, 321  
 UP15030040R50G06 317, 320, 321  
 UP15030040R50G13 317, 321  
 UP20030040R50G06 316, 320, 321  
 UP20030040R50G13 316, 321  
 UP30060040R50G06 315, 320, 321  
 UP30060040R50G13 315, 321  
 UP50050040R50G06 314, 320, 321  
 UP50050040R50G13 314, 321

UPB1JN 321, 327  
 UPB2JN 321, 327  
 US150300 317  
 UT1003040 318, 321, 322  
 UZA4012G06 321, 322  
 UZA5015G13 321, 322  
 UZV16301/4SET 323  
 UZV16301/4SET-90° 323  
 UZV16301/4SET-T 323

## V

VA168-20PRG 199  
 VFP08040L90 (Ø 4 mm) 324  
 VFP10065L100 (Ø 6,5 mm) 324  
 VS1F19N35-20 186  
 VS1F41L30-51 198  
 VS1F41N30-60 189  
 VS1F48L50-105 200  
 VS1F80L30-51 201  
 VS1F80N30-36 190  
 VS1F80N30-60 191  
 VS1F125N49-95 193  
 VS1P48L50-105 200  
 VS1R19N35-20 186  
 VS1R26L35-31 197  
 VS1R26N35-26 187  
 VS1R38N50-60 188  
 VS1R41L30-51 198  
 VS1R41N30-60 189  
 VS1R80L30-51 201  
 VS1R80N30-36 190  
 VS1R80N30-60 191  
 VS1R80N50-36 190  
 VS1R80N50-60 192  
 VS1R125N49-95 193  
 VS1X59L60H5 203  
 VS1X59L60K 202  
 VS1X68L20-105 199  
 VS2F90N30-60 195  
 VS2R80N30-60 194

## W

W20 99, 120

## Z

ZB150786 141  
 ZB150787 141  
 ZB150791 150, 151  
 ZB150792 150, 151  
 ZB170050 142  
 ZK160798M5 129  
 ZSB140L50 149, 150  
 ZSB160L50 149, 150  
 ZSB170L71GH200PCB 151  
 ZSB180L50 149, 150  
 ZSB200L50 149, 150  
 ZSM140L50 115, 143, 144, 148  
 ZSM160L50 143, 144  
 ZSM170L65GH200PCB 103, 145,  
 146  
 ZSM180L50 143, 144, 148, 162  
 ZSM200L50 139, 143, 144, 149  
 ZSMB250L82 147  
 ZSMB500L112 147  
 ZSP40L38-2 155, 156  
 ZSP125L85-1 155, 157, 159  
 ZSP150L100 160  
 ZSP200L55 155  
 ZSP200L100 160, 161  
 ZSP250L100 160  
 ZSX140L50PRG120 142  
 ZSX140L50UPRG 141, 283, 288  
 ZSX140L50UPRG-OPM 286  
 ZSX160L50PRG120 142  
 ZSX160L50UPRG 141  
 ZSX160L50UPRG-OPM 286  
 ZSX180L50PRG120 142  
 ZSX180L50UPRG 141  
 ZSX180L50UPRG-OPM 286  
 ZSX200L50PRG120 142  
 ZSX200L50UPRG 140, 141, 154  
 ZSX200L50UPRG-OPM 286



**Produktion einer Werkstück Familie**  
**Producing a complete workpiece family**

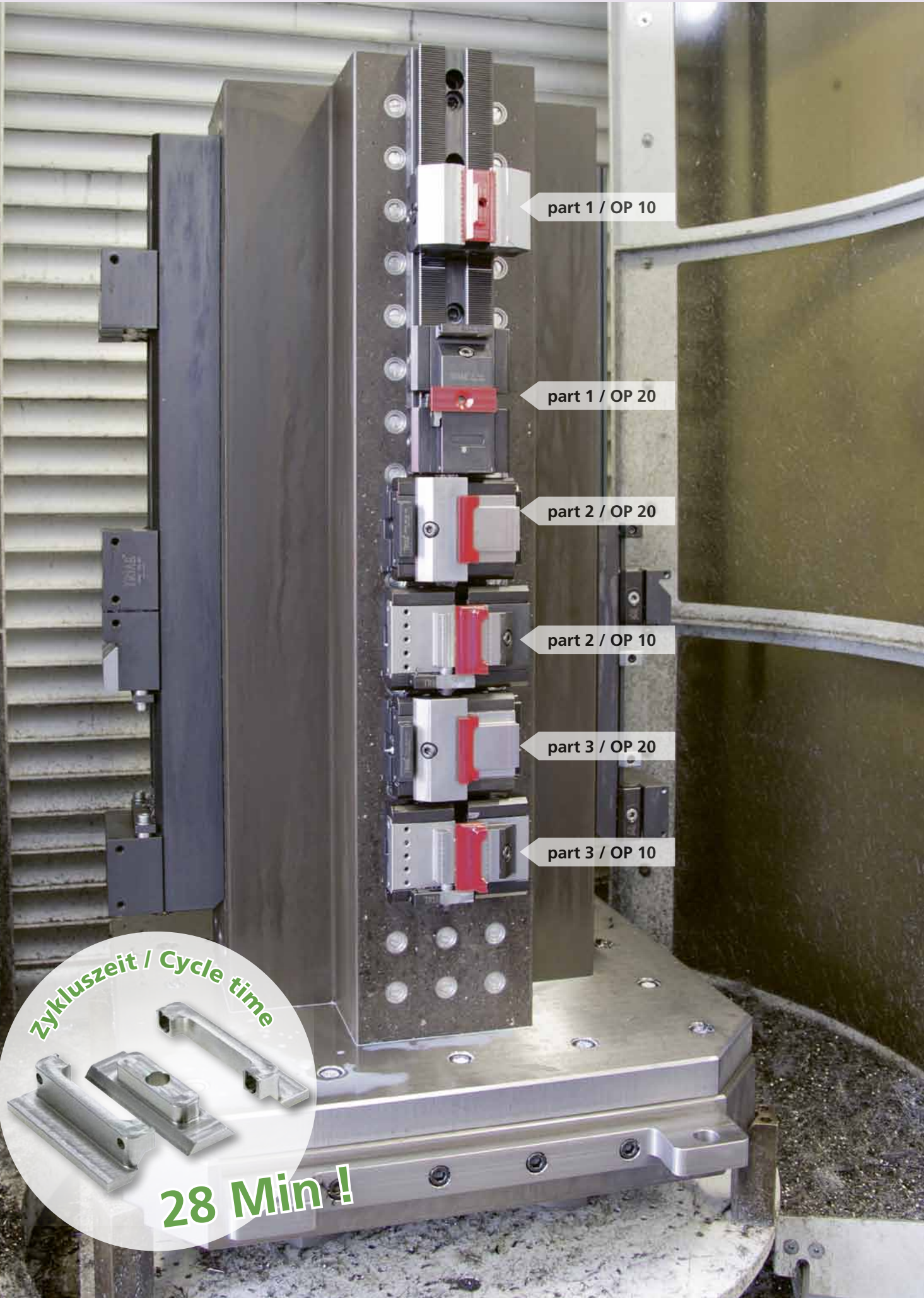

Zykluszeit / Cycle time



**28 Min !**

A circular inset showing three metal workpieces of different shapes. The text 'Zykluszeit / Cycle time' is written in green above the workpieces, and '28 Min !' is written in large green letters below them.





### **powerCLAMP & Saxes powerCLAMP**

Das schnellstverstellbare Mehrfachspannsystem! Die Positionierung der Spannmodule erfolgt mittels einer Verzahnung auf der Schiene. Befestigung mit nur einer Schraube!

### **powerCLAMP & Saxes powerCLAMP**

*The quickest multiple workholding system for easy set up! Positioning of the clamping modules by teeth on the base rail. Repositioning by opening only one single screw!*

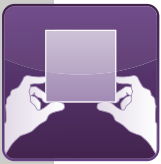

### **triCENTRO & Saxes triCENTRO**

Kleine bis grosse, sowie modulare Zentrischspanner in verschiedenen Ausführungen.

### **triCENTRO & Saxes triCENTRO**

*Small to big modular self centering vises in different variations.*



### **microCLAMP**

Kleinste Module für den Vorrichtungsbau. Sie haben eine grosse Spannkraft (bis 28'000N), der benötigte Abstand zwischen den Werkstücken ist im Optimalfall nur 15 mm.

### **microCLAMP**

*Smallest modules for dedicated fixtures. Having a high clamping force (up to 28'000N) the distance between workpieces is only 15 mm in optimum set up.*



### **aptoCLAMP & Saxes aptoCLAMP**

Die hohe Spannkraft dieses Systems ermöglicht den Einsatz für schwere Zerspanung.

### **aptoCLAMP & Saxes aptoCLAMP**

*The high clamping force of the aptoCLAMP enables heavy cuts.*



### **tripoxyMINERAL**

Spanntürme aus Mineralguss. Die Vibrationsdämpfung ist zehnmal besser als bei Grauguss. Das spezifische Gewicht ist hingegen kleiner als bei Aluminium. Erhältlich in vielen verschiedenen Formen.

### **tripoxyMINERAL**

*Tombstones made of composite concrete. Vibration damping effect is ten times better than with cast iron. Specific weight on the other hand is less than aluminum. Available in many different shapes.*



### **oppSystem & Saxes oppSystem**

Unser Nullpunkt-Palettiersystem ermöglicht ein genaues Positionieren von Mehrfachspannsystemen, Schraubstöcken und Vorrichtungen auf Maschinentischen oder Spanntürmen.

### **oppSystem & Saxes oppSystem**

*Our zero-point palleting system allows exact positioning of multiple workholding systems, vices and dedicated fixtures on machining tables or tombstones.*



### **trivaCLAMP**

Vakuumspannsystem: Bestens geeignet für plattenförmige Werkstücke (auch nicht magnetische). Es können sowohl Druckstellen als auch Deformationen an labilen Teilen vermieden werden.

### **trivaCLAMP**

*Workholding by vacuum: Suited for plateshaped workpieces (also for non magnetical). Pressure marks as well as deformations on soft parts can be avoided.*



### **triGEL**

Unser Gefrierspannsystem. Sehr gut geeignet für unförmige Teile. Es erlaubt mehrseitiges Bearbeiten ohne Neuspannen. Das Haftvermögen ist sehr gross, wobei die Gefrier- und Auftauzeiten sehr gering sind.

### **triGEL**

*Workholding by freezing: Well suited for strangely shaped parts. It allows processing from more than one side without unclamping. Holding effects are very strong whereas freezing and defrosting times are very short.*

**TRIAG**  
INTERNATIONAL

**Triag International AG**

Bösch 84 CH-6331 Hünenberg

+41 41 727 27 77

spannen@triag-int.ch

clamping@triag-int.ch

**triag-int.ch**

Official Website

