

**microCLAMP**

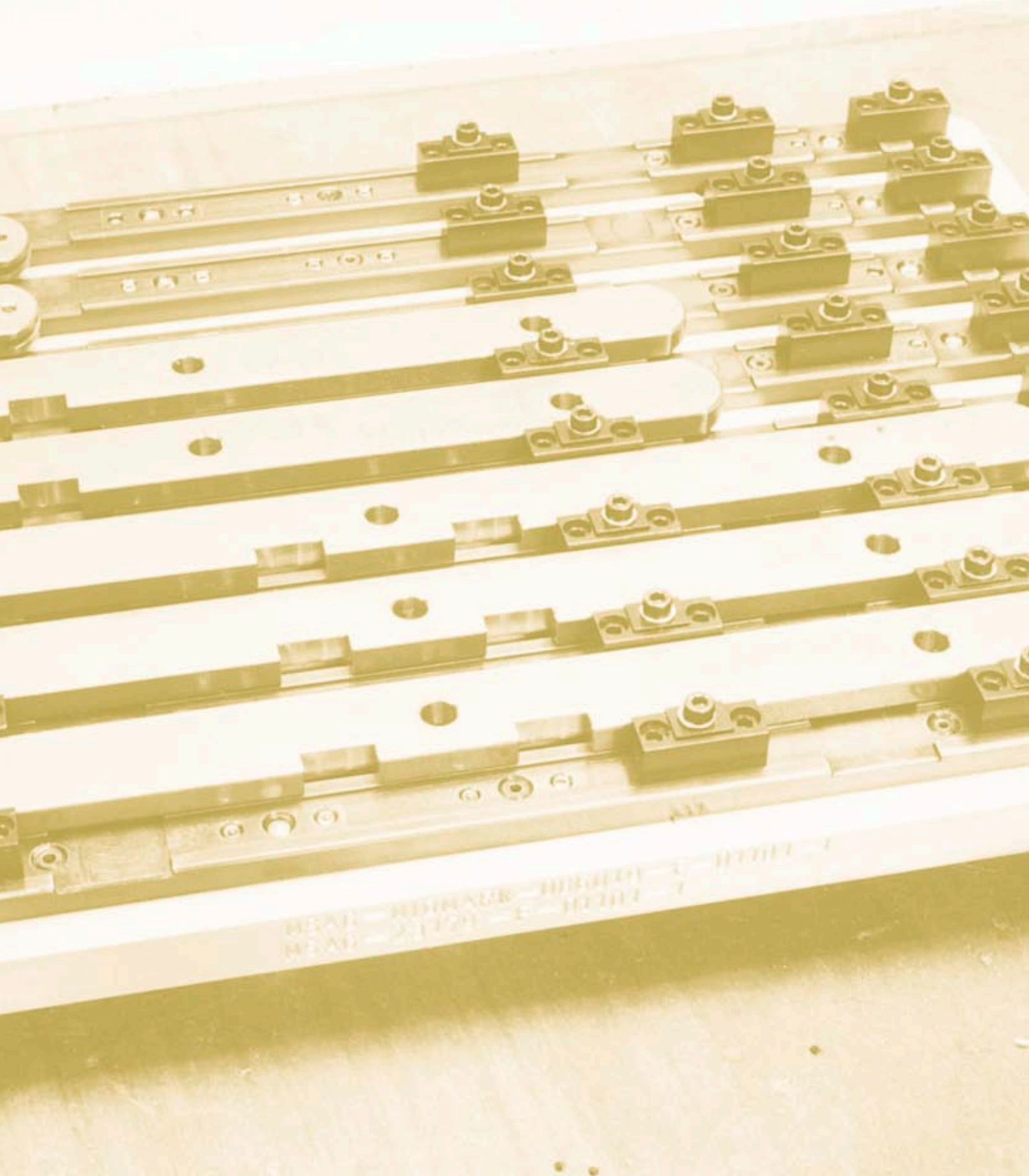

# compactCLAMP

Mehrfachspannsystem / Multiple workholding system

**Nur noch Ersatzteile und  
Nachlieferungen!  
Keine Compact Clamp  
Neuentwicklungen mehr!**

Beim Compact Clamp lassen sich die Spannmodule auf einer Basisschiene mittels Passstiften massgenau positionieren. Die Schienen sind mit einem Lochraster mit 7,5 mm Teilung, die Spannmodule mit einer 10 mm-Teilung versehen. Dank Anwendung des Nonius-Prinzips entsteht ein kleinstmöglicher Positionierschritt von 2,5 mm. Bei einem Backenhub von 4 mm ist es somit möglich, an jedem beliebigen Punkt der Schiene nullpunktbezogen zu spannen. Ab 20 mm ist die Bearbeitung von drei Seiten möglich. Da das Spannmodul mit vier Schrauben in den T-Nuten verankert wird, ist es sinngemäss auch möglich, an Stelle der Original-Spannmodule individuelle Vorrichtungen und Sonderbacken zu befestigen. Das Compact Clamp Spannsystem ist ein System für Tüftler. Praktisch keine Spannprobleme bleiben damit ungelöst. Dafür sind die Umrüstzeiten etwas länger als beim Power Clamp. Compact Clamp-Basisschienen sind in den Längen 113 - 750 mm lieferbar. Die angebotenen Befestigungsraaster sind 40 und 50 mm. Neben den Stahlschienen werden für leichte Arbeiten auch Schienen aus Aluminium hergestellt.

**Only spare parts and  
additional deliveries! No  
more new Compact Clamp  
developments!**

*In the Compact Clamp, the vise modules are positioned precisely on a base rail by means of alignment pins. On the base rail, positioning holes are located on a 7,5 mm grid, while on the vise module there is one with a 10 mm spacing. Following the vernier principle, the smallest possible positioning step is therefore 2,5 mm. With a jaw movement of 4 mm it is therefore possible to clamp the workpiece in any desired position with a known distance to program Zero (original datum face). From 20 mm up, three sided machining is possible. Special jaws or dedicated fixtures may easily be bolted onto the rails in place of standard vise modules if the need arises. They may be anchored in the T-slots and located by using alignment pins in the positioning holes. Hence the Compact Clamp is the ideal workholding system for "do it yourself" customers. Change over times are longer than with the Power Clamp, though. Available Compact Clamp base rails lengths: 113 - 750 mm. The fastening grids on the rails are 40 and 50 mm. In addition those made of steel we also produce rails made of aluminum for light work.*

Sie können den Katalog unter der folgenden  
Webadresse herunterladen!

You can download the catalogue at the  
web address below!

[www.triag-int.ch/wp-content/uploads/compactCLAMP.pdf](http://www.triag-int.ch/wp-content/uploads/compactCLAMP.pdf)

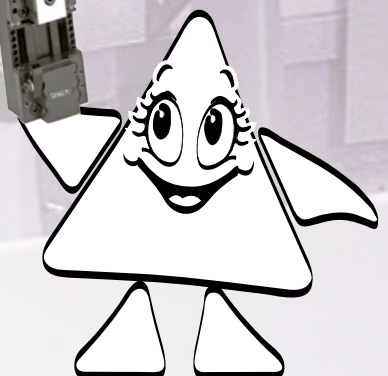



Einleitung | *Introduction* ..... 166 - 167

Anwendungsbeispiele | *Examples of application* ..... 168 - 171



Spannkraft und Drehmoment | *Workholding force and torque* ..... 173

Vorrichtungsbau - Präge- und Anschlagmodule (Linear)  
*For dedicated fixture - stamping- and end modules (linear)* ..... 174 - 176

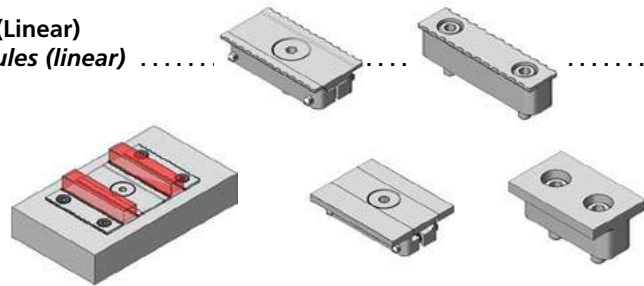

Niederzugspannmodule | *Pull down clamp modules* ..... 177 - 195

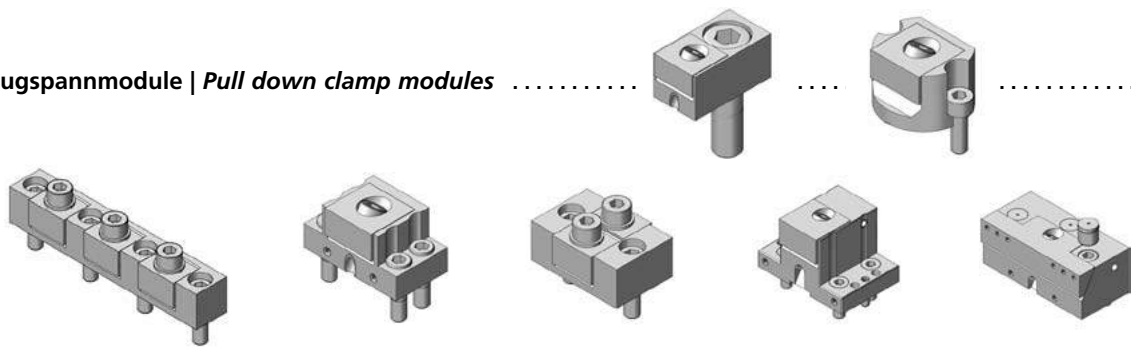

Linearspannmodule | *Linear clamping modules* ..... 196 - 203

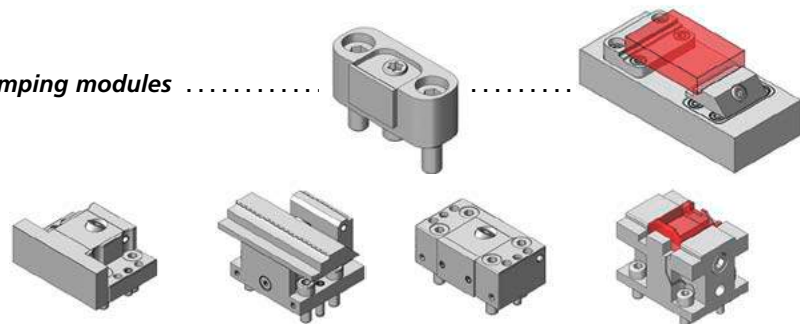

Zubehör | *Accessories* ..... 204 - 205





Zum Aufbau kundenspezifischer Sondervorrichtungen für höchste Werkstückdichte im Arbeitsraum von Bearbeitungszentren ist das Spannsystem Micro Clamp ausgelegt (Spezielle Anschlagbacken, siehe Bild). Sehr kompakte Spannmodule mit Prägebacken verwirklichen eine zuverlässige Aufspannung bei nur etwa 2 mm Verlust an Rohmaterial

*Clamps for dedicated fixtures for high density to get your best output from your machine. Clamping modules in different sizes and shapes and jaws with serrations also flat and carbide coated are available.*

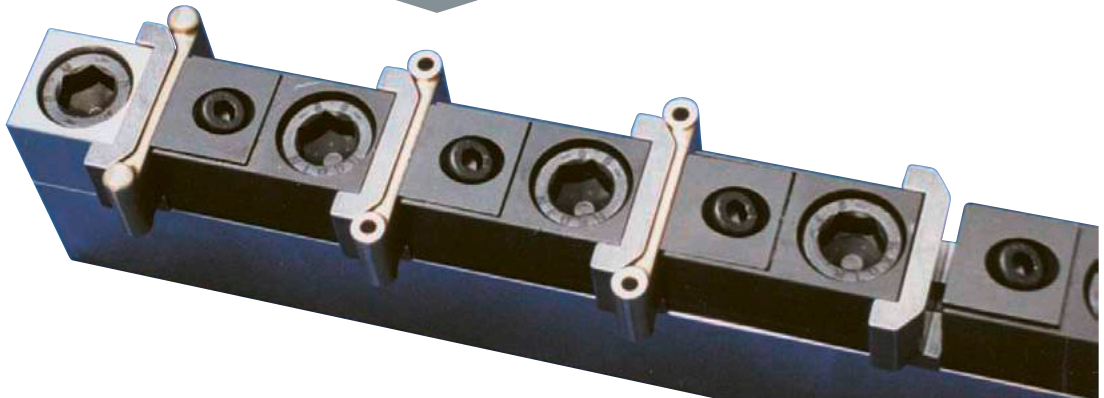

**Kleinst-Spannmodule für den Vorrichtungsbau. *Extremely small clamping modules for dedicated fixtures.***

**Hohe Spanndichte**

Die Spannmodule haben auf der Vorderseite eine Spannbacke, die Rückseite ist zu den Befestigungsbohrungen massgenau geschliffen oder gefräst. Damit kann diese Anschlagfläche für das folgende Werkstück genutzt werden. Diese Anordnung lässt eine sehr hohe Spanndichte zu. Beim kleinsten Micro Clamp-Modul sind nur 15 mm Spannabstand erforderlich.

***High workholding density***

*These clamping modules have a clamping jaw on the front, while rear is precisely ground or milled with reference to the fixing holes. This means that it can be used as a datum face for the following workpiece. This arrangement allows very high clamping densities. Only 15 mm clamping clearance is needed between workpieces using the smallest Micro Clamp module.*

- Maximale Spannkraft der Module 2,8t (28'000N)
- Benötigter Platz zwischen den Werkstücken ab 15 mm
- Spannhub ab 1,5 mm
- Genaue Positionierung durch Passschrauben und Positionierstifte

- *Clamping force up to 2,8t (28'000N)*
- *Space between workpieces only 15 mm*
- *Stroke of jaw from 1,5 mm*
- *Precise positioning by ground shoulder screws or dowel pins*

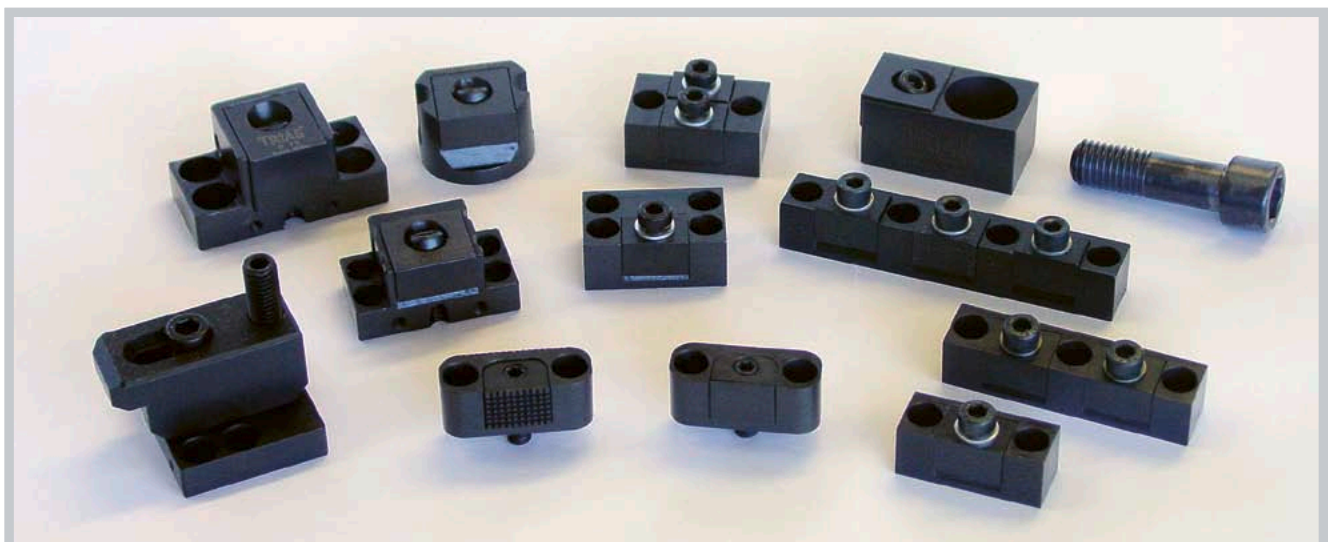

Ein grosses Angebot an verschiedensten Spannmodulen.  
*A wide range of clamp modules in different sizes are available*

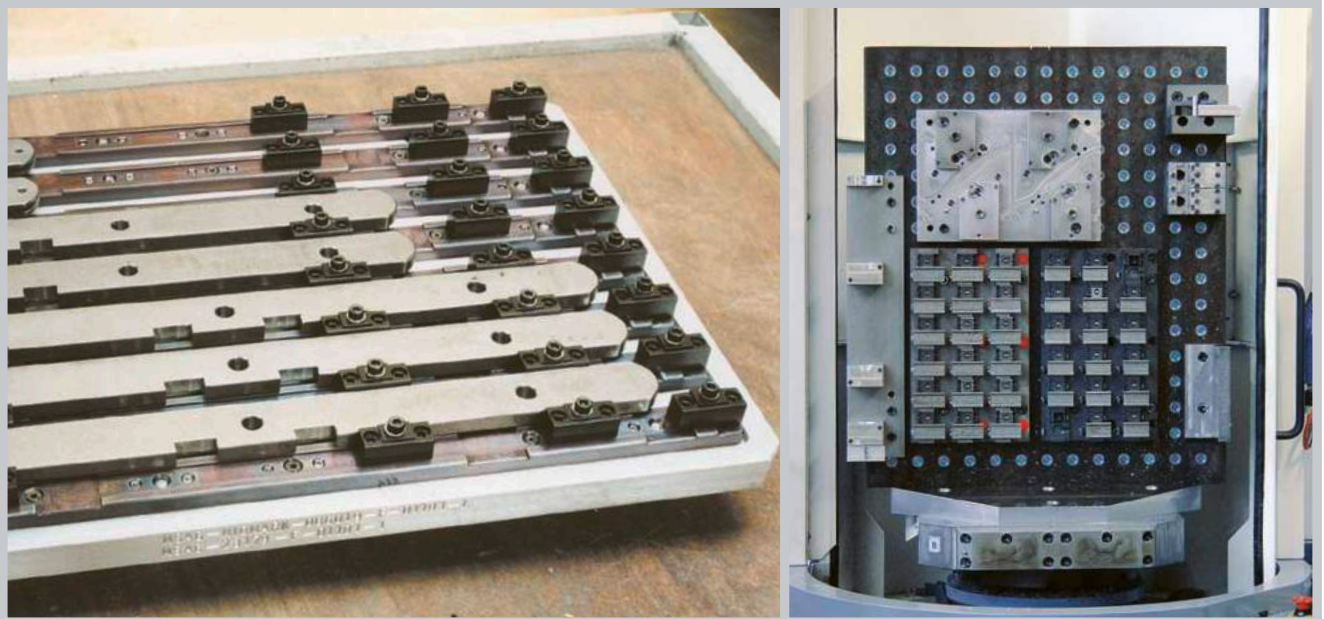

Hohe Spanndichte für Werkstücke in grossen Stückzahlen.  
*High density fixture plates for repeating orders in high quantities*

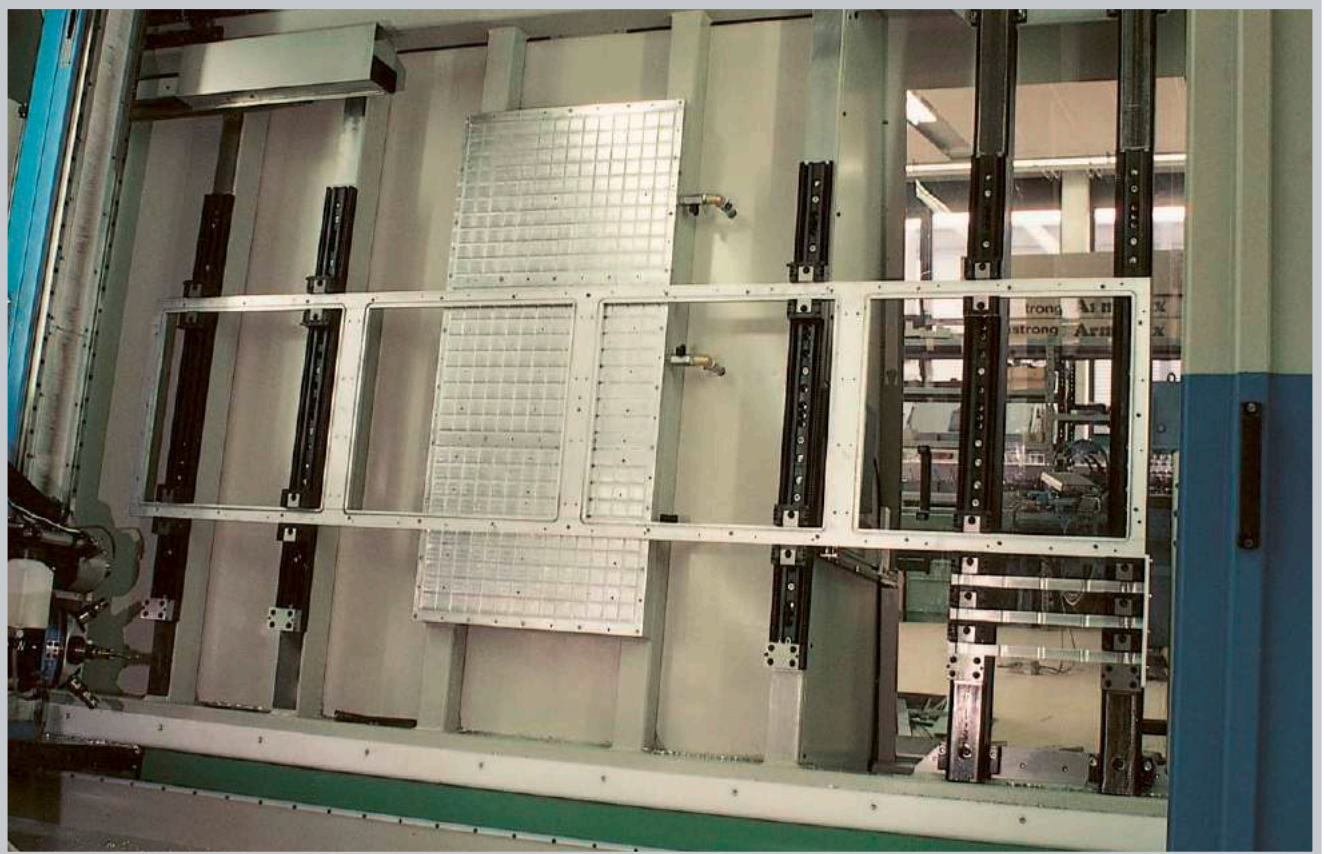

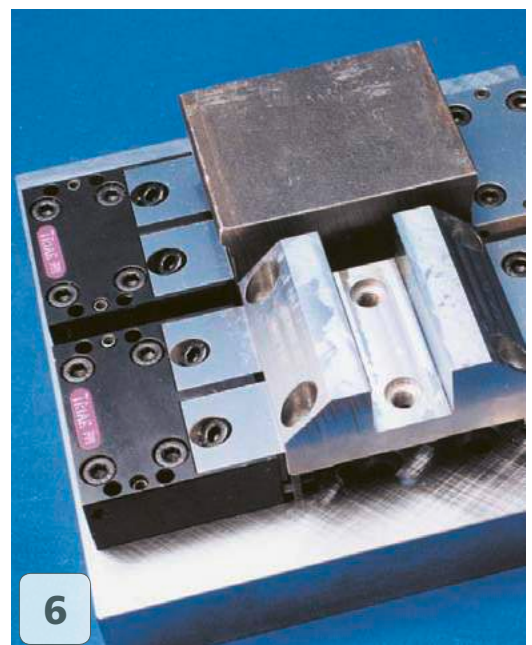
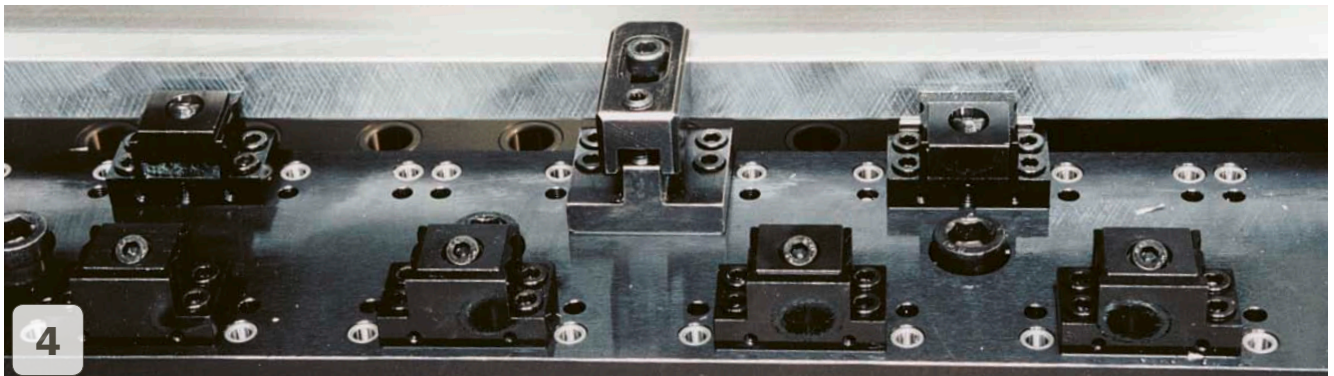
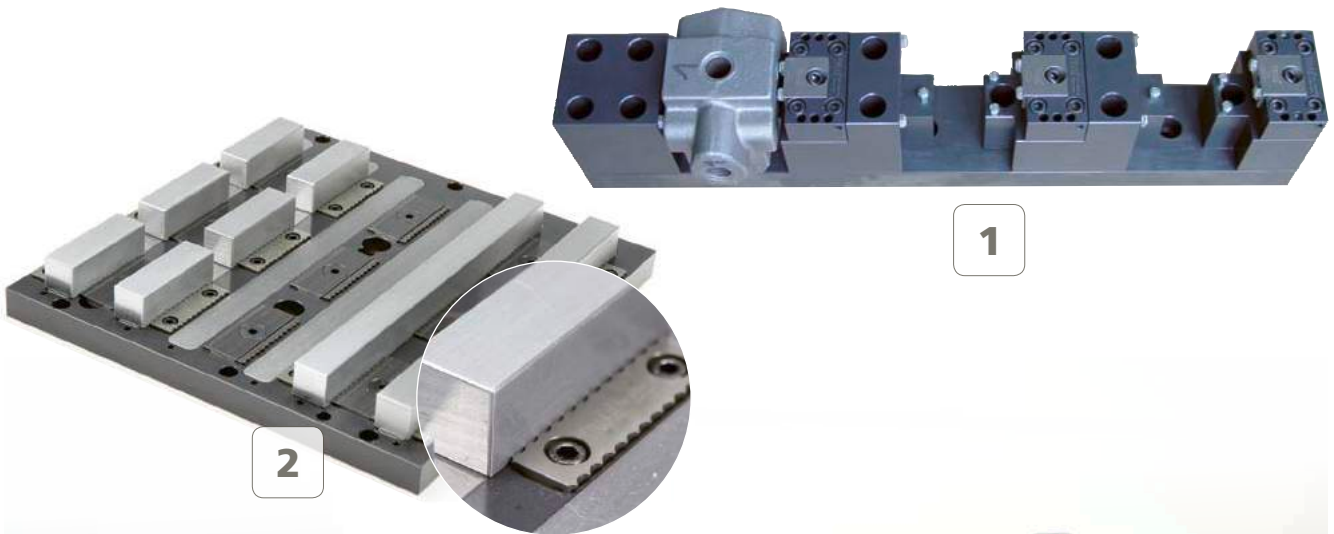

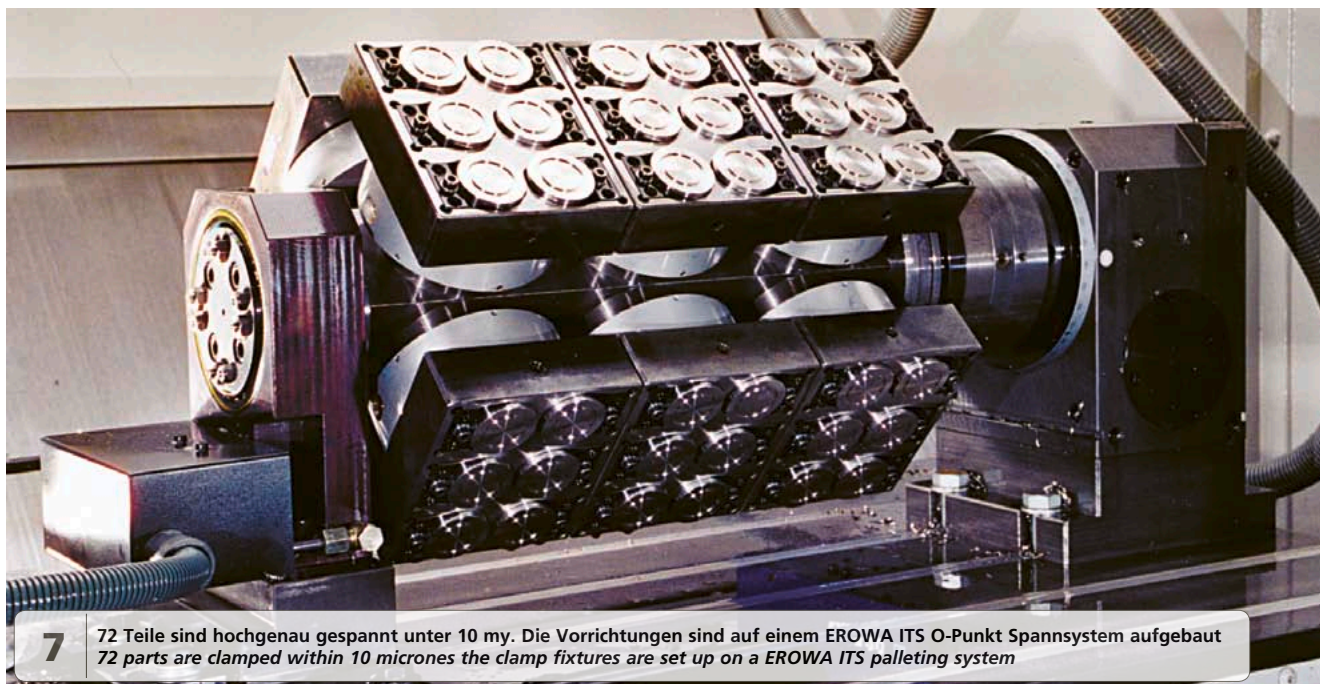

7 72 Teile sind hochgenau gespannt unter 10 my. Die Vorrichtungen sind auf einem EROWA ITS O-Punkt Spannsystem aufgebaut  
72 parts are clamped within 10 microns the clamp fixtures are set up on a EROWA ITS palleting system

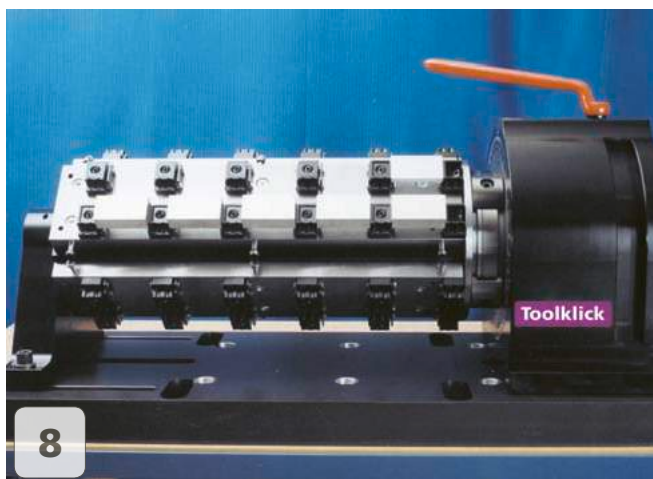

8

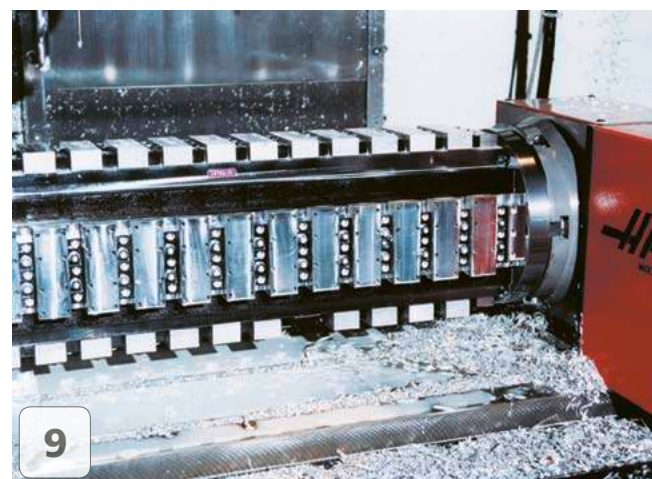

9

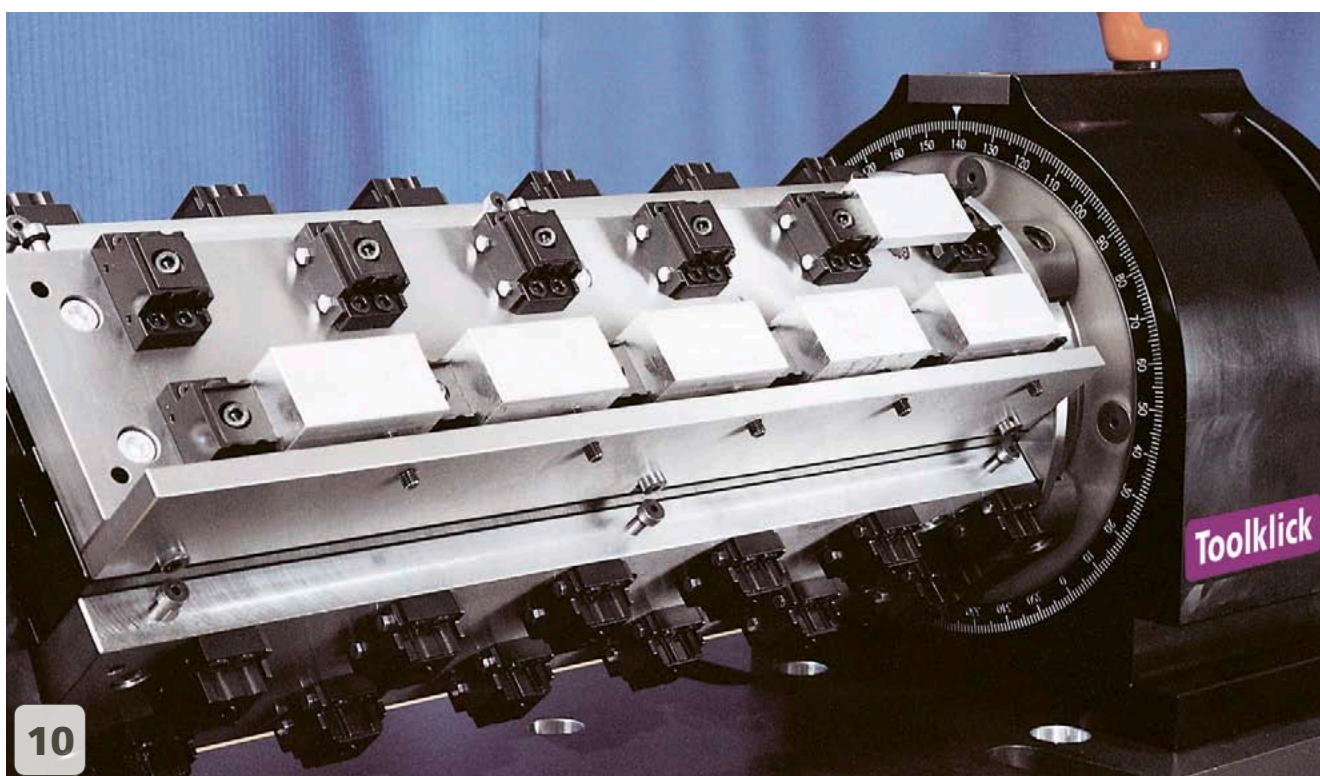

10



11

84 Teile sind gespannt mit Micro Clamp und werden jeweils nachts unbemannt produziert  
84 parts are clamped with Micro Clamp and are machined always at night unmanned



12

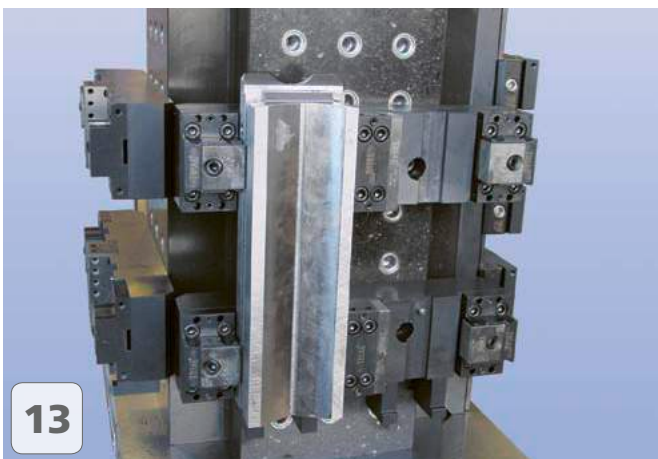

13



16

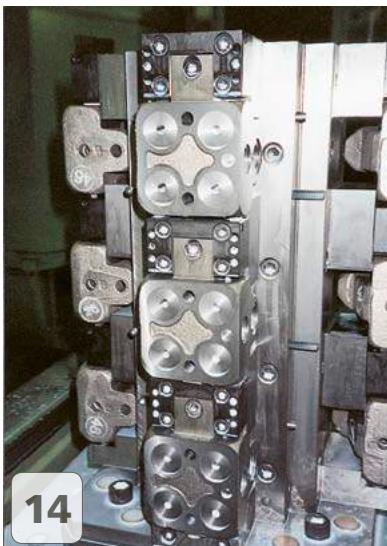

14



15



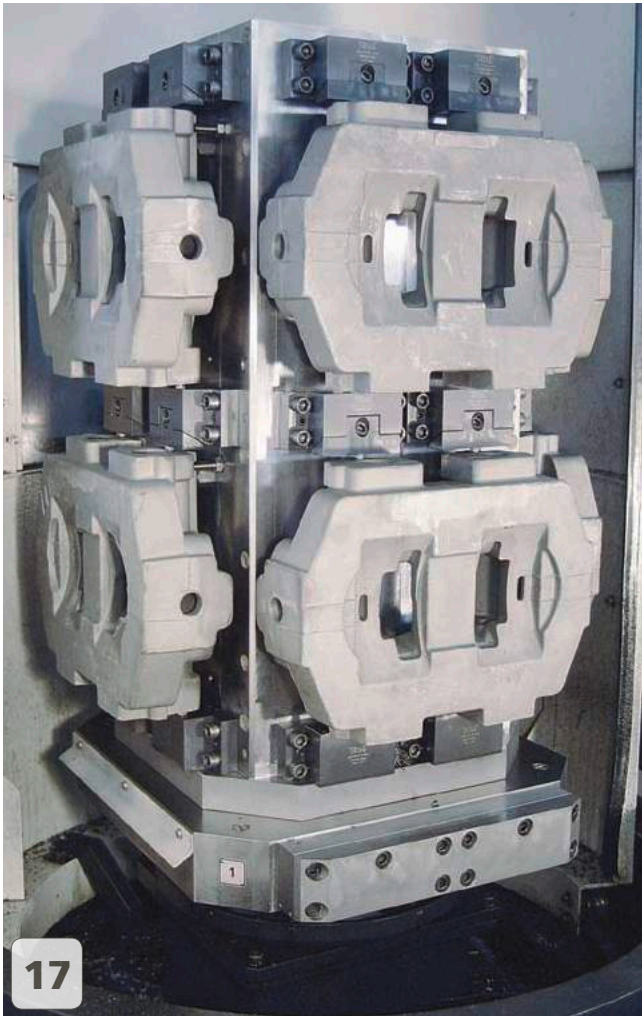

17



18

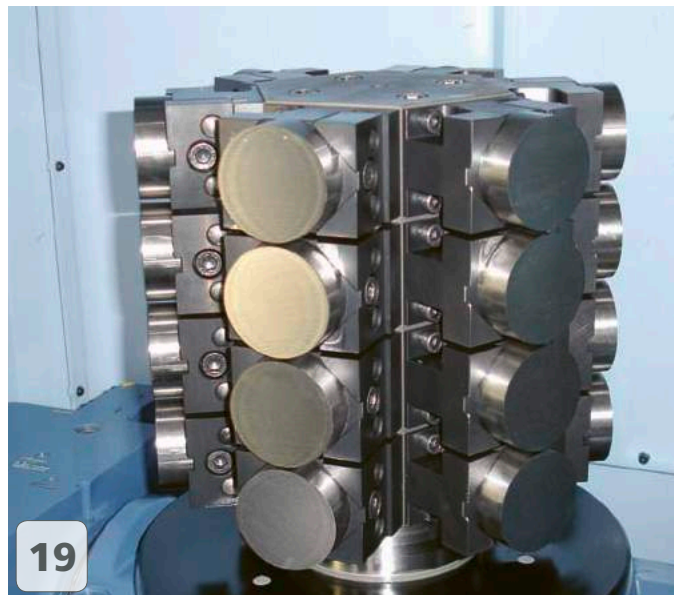

19



20



21



System System		bei Anschlagmodulen for end module	Modulnutzbreite Module clamping width	Modulnutztiefe / -höhe Module clamping depth or height
A	Apto Clamp	N nitriertgehärtet nitrided		<b>MS:</b> Tiefe Depth  <b>VS:</b> Höhe Height
P	Power Clamp	D durchgehärtet through hardened		
C	Compact Clamp	<b>bei Spannmodulen for vice modules</b>		
M	Micro Clamp	1 2 3 Anzahl Spannbacken Number of jaws	19 25 26 34 43 48 58 61 68 78 94 125	
V	Vorrichtungsbau module Workholding modules for dedicated fixtures	- keine Spannbacke no clamping jaw		

**M S 1 F 35 N 14 -01**

Modultyp Type of module	
A	Anschlagmodul End module
S	Spannmodul Clamping module
T	Trägermodul Supporting module
R	Rohling / Rundes Modul Blank / Round mod- ule
V	Vertikalspannmodul Vertical clamp

Anschlagfläche der Module Datum face	
F	Anschlagfläche glatt Datum face flat
R	Anschlagfläche geriffelt Datum face double serrated
D	eine Seite glatt, eine Seite geriffelt one face flat, one face double serrated
G	Anschlagfläche gerillt Datum face serrated
X	spezielle Ausführung special execution
5X	5axes Clamp
P	prägen stamping

Backenhub Stroke of clamping jaw	
N	Niederzug Pull down
L	linear / parallel linear / parallel
-	ohne Spannbacke no clamping jaw

Spannbackentyp Type of clamping jaw	
B01	Spannbacke Clamping jaw
- B151	
-01	Modul ohne Spann- backen Module without clamp- ing jaw
- -150	



# ACHTUNG / CAUTION

**WICHTIG:** Die im Micro Clamp Kapitel angegebenen Drehmomente sind die absoluten Maximalwerte. Über die Spannkraften gibt die untenstehende Tabelle Auskunft.

**IMPORTANT:** The torque numbers specified in the Micro Clamp chapter represent the absolute maximum. The table at the bottom of this page provides further information on the workholding forces.

Niederzug-Spannmodule Pull down module	MC-Module	Schraube Screw	Drehmoment Torque		Spannkraft Workholding force		
			Nm	(lb-ft)	~daN	~(lb)	~t
	MR1F 30N23 -07	M5	10	7,4	= 1020	2250	1,02
	MS1F 22N40 -07		10	7,4	= 1020	2250	1,02
	MS1F 24N22 -07		10	7,4	= 1020	2250	1,02
	MS1R/F 25N25 -13	M6	15	11	= 1520	3350	1,52
	MS1F 35N14 -01	M5	10	7,4	= 1020	2250	1,02
	MS1F 35N22 -01		10	7,4	= 1020	2250	1,02
	MS2X 25N23 -01		10	7,4	= 1020	2250	1,02
	MS2F 60N14 -01		10	7,4	= 1020	2250	1,02
	MS3F 85N14 -01		10	7,4	= 1020	2250	1,02
	VS1R 19N35 -20		M6	15	11	= 1520	3350
	VS1R 26N35 -26	M8	25	18,4	= 2100	4630	2,10
	VS1R 38N50 -60		25	18,4	= 2100	4630	2,10
	VS1R/F 41N30 -60		25	18,4	= 2100	4630	2,10
	VS1R/F 80N30 -36		25	18,4	= 2100	4630	2,10
	VS1R 80N50 -36		25	18,4	= 2100	4630	2,10
	VS1R/F 80N30 -60		25	18,4	= 2100	4630	2,10
	VS1R 80N50 -60	M10	25	18,4	= 2100	4630	2,10
	VS1R/F 125N49 -95		40	29,5	= 2800	6170	2,80
VS2R 80N30 -60	25		18,4	= 2100	4630	2,10	
VS2F 90N30 -60	25		18,4	= 2100	4630	2,10	
	MS1F (MS1R) 35L14 -152	M6x0,5	10	7,4	= 570	1260	0,57
	MS2P (MS2P) 58L14 PRG15	M8	15	11	= 600	1320	0,6
	MS2F (MS1F) 58L14 W251		15	11	= 600	1320	0,6
	VS1R 26L35 -31		25	18,4	= 2100	4630	2,10
	VS1R/F 41L30 -51	25	18,4	= 2100	4630	2,10	
	VS1R/F 80L30 -51	25	18,4	= 2100	4630	2,10	
	VS1X 68L20 -105	M10	40	29,6	= 1600	3530	1,60
	VS1X 59L60 K		50	37	= 1880	4140	1,88
	VS1X 59L60 H5		50	37	= 1640	3620	1,64

**Die Spannbacken und Schrauben regelmässig fetten!**  
*Lubricate clamping jaw and screw regularly with grease!*

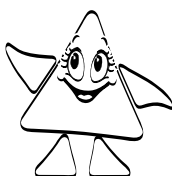

Schraube Screw	Drehmoment Torque		Spannkraft Workholding force		
M5 + M6	4	3	= 500	1100	0,50
	5	3,7	= 580	1280	0,58
	6	4,4	= 690	1520	0,69
	7	5,2	= 780	1720	0,78
	8	5,9	= 880	1940	0,88
	9	6,6	= 980	2160	0,98
M6	10	7,4	= 1020	2250	1,02
	12	8,9	= 1220	2690	1,22
	14	10,4	= 1450	3200	1,45
M8	15	11	= 1520	3350	1,52
	4	3	= 410	900	0,41
	5	3,7	= 490	1080	0,49
	6	4,4	= 560	1250	0,56
	7	5,2	= 660	1460	0,66
	8	5,9	= 730	1610	0,73
	9	6,6	= 810	1790	0,81
	10	7,4	= 900	1980	0,90
M10	15	11	= 1520	3350	1,52
	20	14,8	= 1810	3990	1,81
	25	18,4	= 2100	4630	2,10
	10	7,4	= 400	880	0,40
	20	14,8	= 1400	3090	1,40
M10	30	22,1	= 2000	4410	2,00
	40	29,5	= 2800	6170	2,80



Keilspanner in weicher Ausführung zum Bearbeiten von Formbacken.

Double angle clamps with soft jaws for making shaped forms.

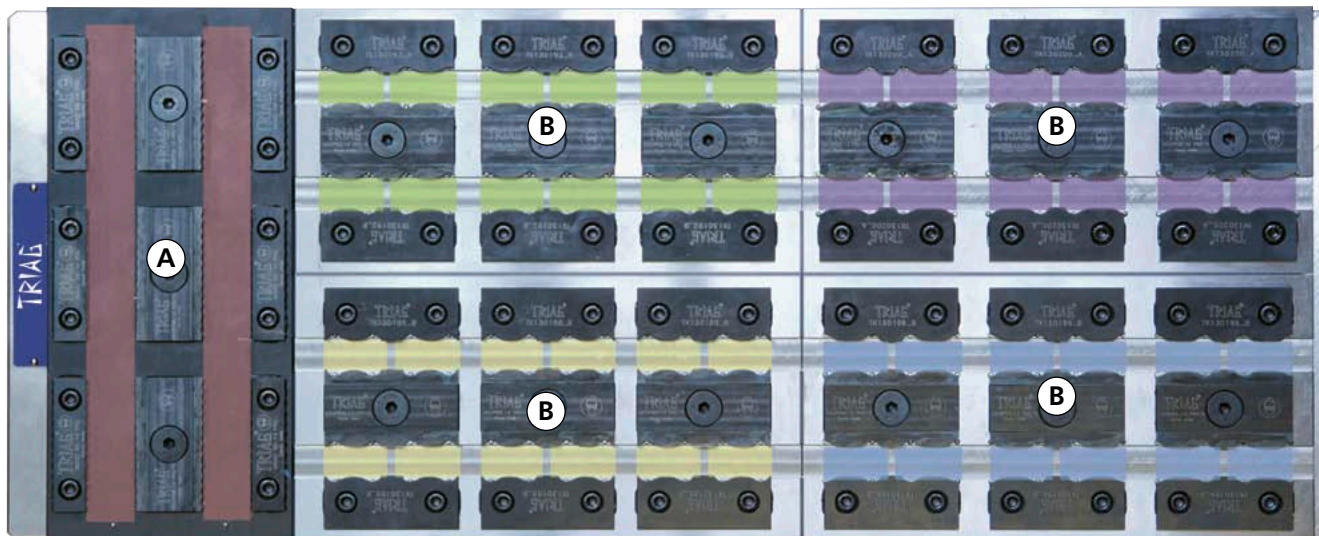

**A** Prägbacken Spanntiefe 1,8mm  
 12 Werkstücke werden hergestellt  
*First clamp 12 parts with stamping jaws  
 clamping depth 1,8mm*

**B** 4 x 12 verschiedene Teile werden in der  
 2. Spannung bearbeitet  
*4 times 12 different parts are machined  
 in the second operation*

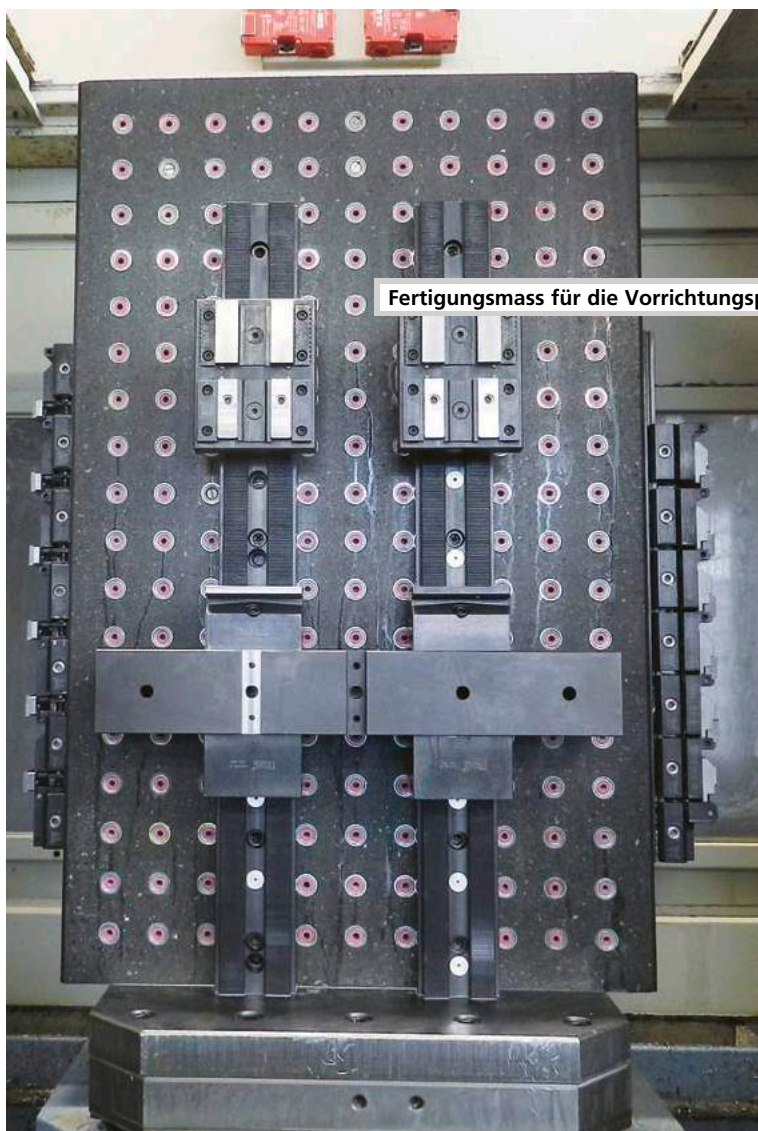

Fertigungsmass für die Vorrichtungplatte: / Machining data for the fixture plate: p. 175

**Fräser / Milling cutter**

Der abgebildete Fräser benötigt man für die Herstellung der «Kerben».  
 Siehe Fertigungsmasse für die Vorrichtungplatte Seite 175.

*The illustrated milling cutter is required for the production of "notches".  
 Manufacturing drawing for the fixture plate on page 175.*

45°	d	D	L1	H	z	L
TK150057	6	6,0	24,0	1,5	3	58

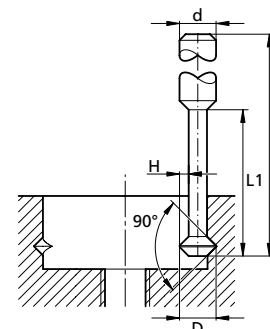

Fertigungsmasse für die Vorrichtungplatte / Machining data for the fixture plate

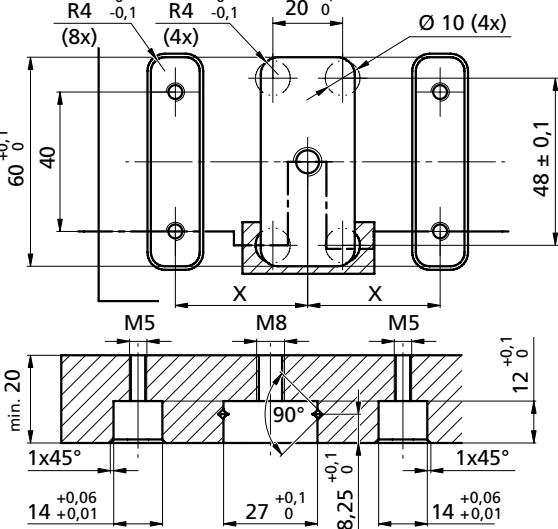
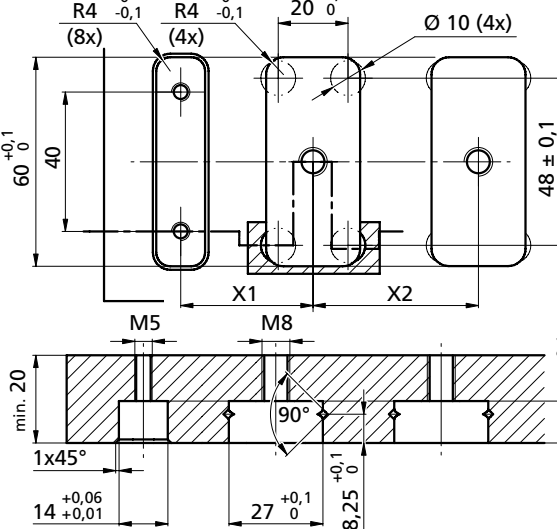
	
<p><b>Mass</b>  <b>X (X1) = B + 24 mm</b>  <b>Beispiel:</b>          Bauteilbreite = 14 mm</p> <p><b>Dimension</b>  <b>X (X1) = B + 24 mm</b>  <b>Example:</b>          Width of component part = 14 mm</p> <p>Taschenabstand          X = 14 + 24 = 38          Das ergibt eine Einlegeluft von 0,8 mm          (Hub bis 2,7 mm)</p>	<p><b>Mass</b>  <b>X2 = B + 33,5 mm</b>  <b>Beispiel:</b>          Bauteilbreite = 14 mm</p> <p><b>Dimension</b>  <b>X2 = B + 33,5 mm</b>  <b>Example:</b>          Width of component part = 14 mm</p> <p>Taschenabstand          X = 14 + 33,5 = 47,5          Das ergibt eine Einlegeluft von 0,8 mm          (Hub bis 2,7 mm)</p>

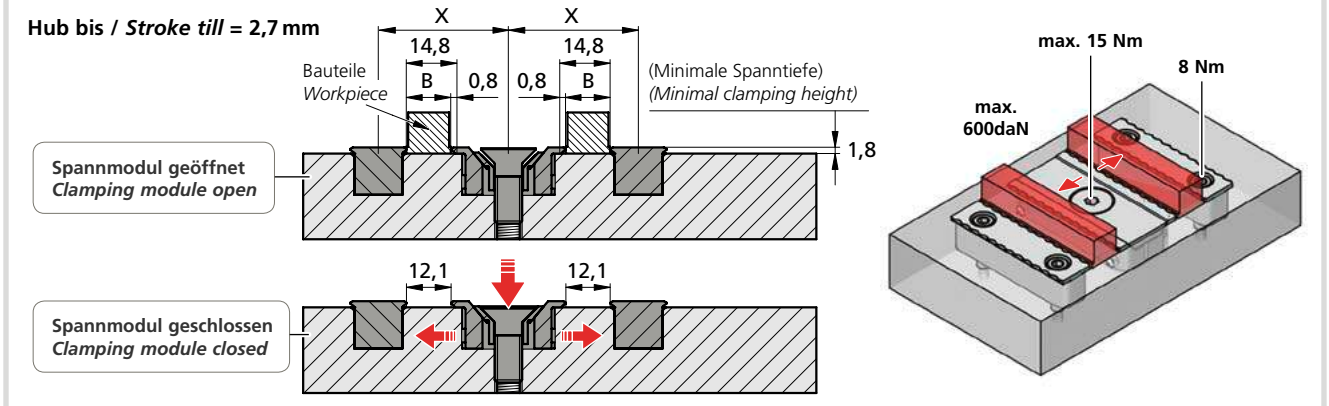
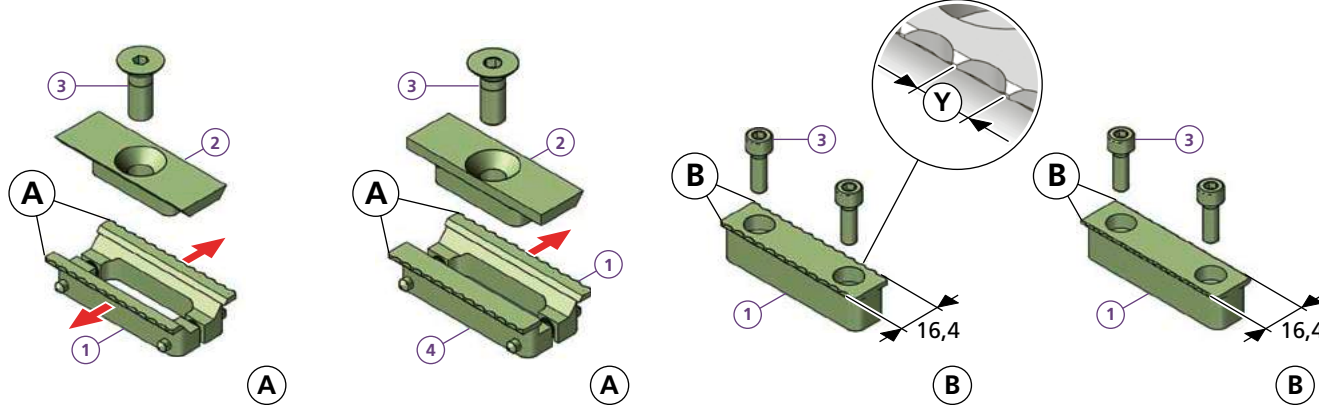

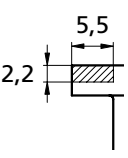

<p><b>MS2P58L14PRG15</b></p> <ul style="list-style-type: none"> <li>1 2x TK120225</li> <li>2 1x TK120227</li> <li>3 1x M8X22DIN7991</li> </ul> <p>Y 4,7 mm</p> <p>i 57HRC</p> <p>kg ~0,12</p>	<p><b>MS1P58L14PRG15</b></p> <ul style="list-style-type: none"> <li>1 1x TK120225</li> <li>2 1x TK120721</li> <li>3 1x M8X22DIN7991</li> <li>4 1x TK120720</li> </ul> <p>Y 4,7 mm</p> <p>i 57HRC</p> <p>kg ~0,12</p>	<p><b>MAND58-14PRG</b></p> <ul style="list-style-type: none"> <li>1 1x TK120226</li> <li>3 2x M5X16ISO4762</li> </ul> <p>Y 4,7 mm</p> <p>i 57HRC</p> <p>kg ~0,08</p>	<p><b>MAND58-14PRG6</b></p> <ul style="list-style-type: none"> <li>1 1x TB150282</li> <li>3 2x M5X16ISO4762</li> </ul> <p>Y 6,0 mm</p> <p>i 57HRC</p> <p>kg ~0,08</p>
---	--	--	---

**Zum Erstellen Ihrer individuellen Formbacke:**  
 Schnittzeichnung zum Ermitteln der maximalen Bearbeitungsprofiltiefe  
**If a dedicated jaw is being machined:**  
 Sectional drawing to determine the maximum machining depth

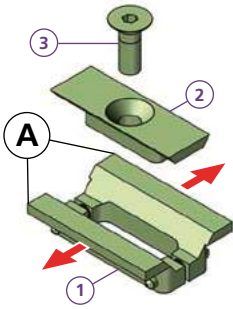
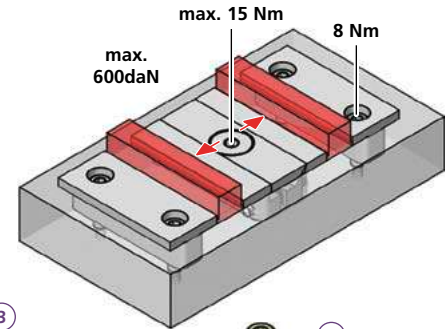

für / for TK120531 | TK120531 | TK120529 | TK160554



**MS2F58L14W251**

- 1 2x TK120531
- 2 1x TK120227
- 3 1x M8X22DIN7991

i \*

kg ~0,12

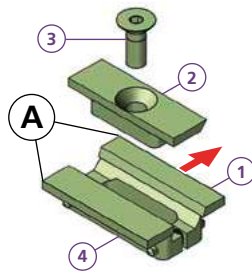

**MS1F58L14W251**

- 1 1x TK120531
- 2 1x TK120721
- 3 1x M8X22DIN7991
- 4 1x TH130566

i \*

kg ~0,12

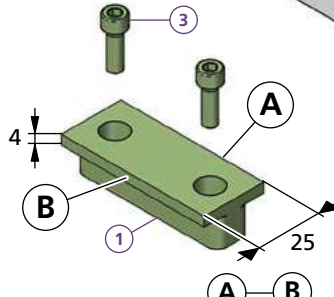

**MANF58-14W25**

- 1 1x TK120529
- 3 2x M5X16ISO4762
- i \*

**MANF58-14F25**

- 1 1x TK150033
- 3 2x M5X16ISO4762
- i HV700 x 0,2mm

kg ~0,11

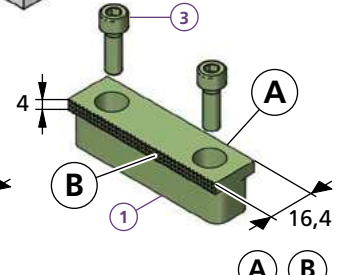

**MANF58-14RF**

- 1 1x TB160563
- 3 2x M5X16ISO4762

i HV700 x 0,2mm

kg ~0,11

**p. 175 Fertigungsmass für die Vorrichtungslatte: / Machining data for the fixture plate:**

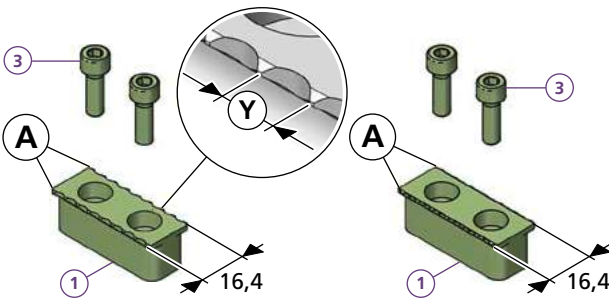

**MAND38-14PRG**

- 1 1x TB150234
- 3 2x M5X16ISO4762
- Y 4,7 mm

i 57HRC

kg ~0,08

**MAND38-14PRG6**

- 1 1x TB150283
- 3 2x M5X16ISO4762
- Y 6,0 mm

i 57HRC

kg ~0,08

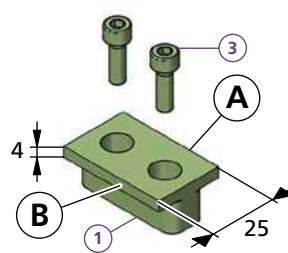

**MANF38-14W25**

- 1 1x TK160554
- 3 2x M5X16ISO4762
- i \*

**MANF38-14F25**

- 1 1x TK160553
- 3 2x M5X16ISO4762
- i HV700 x 0,2mm

kg ~0,08

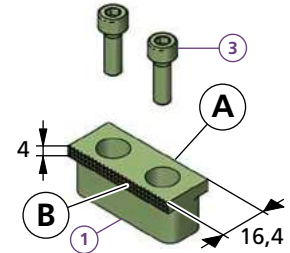

**MANF38-14RF**

- 1 1x TB170062
- 3 2x M5X16ISO4762

i HV700 x 0,2mm

kg ~0,08

**Fertigungsmass für die Vorrichtungslatte**  
 Machining data for the fixture plate

für / for TB150234 | TB150283 | TK160554 | TK160553 | TB170062

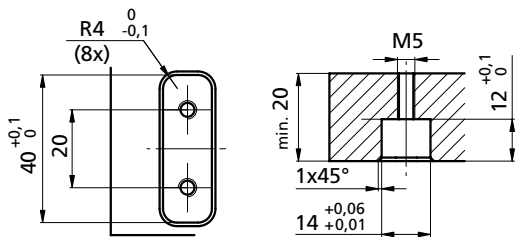

**Spannmodule**  
**Clamping module**



**MV1F20L35BV1**

**microCLAMP**

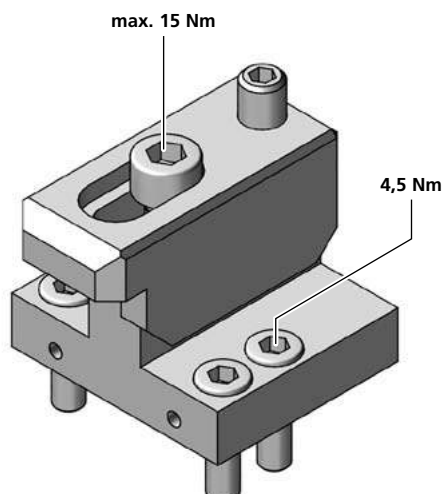
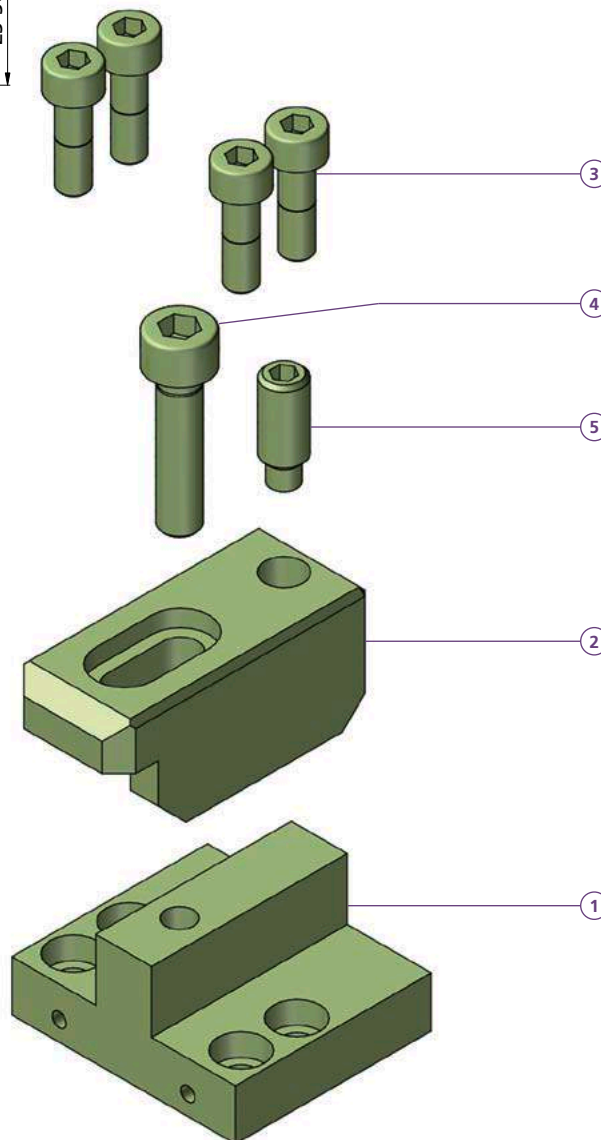
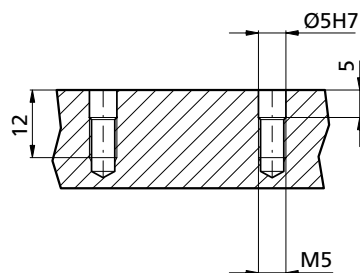
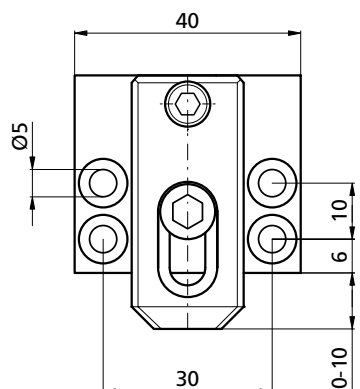
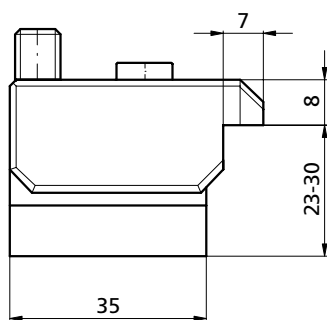
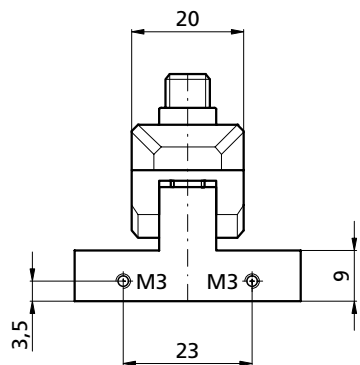

**MV1F20L35BV1**

- ① 1x TF140710
  - ② 1x BV1
  - ③ 4x M550
  - ④ 1x M6X25ISO4762
  - ⑤ 1x M8x20ISO4028
- kg ~0,225

Bestellbeispiel / Ordering example : **MV1F20L35BV1**



# MR1F30N23-07

microCLAMP

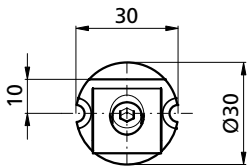
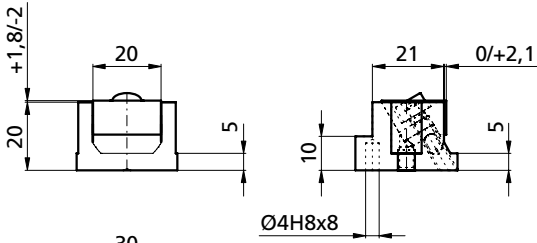
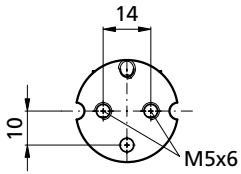

Ø4H8x8

Version 2

Version 1

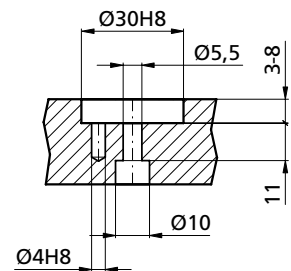
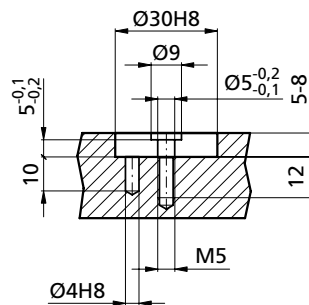
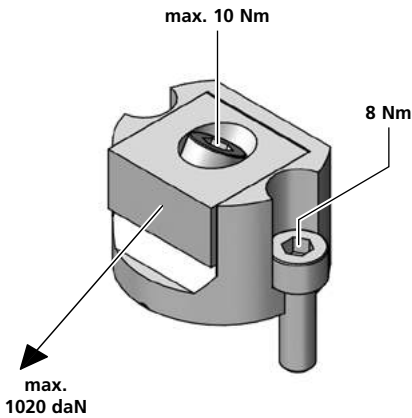
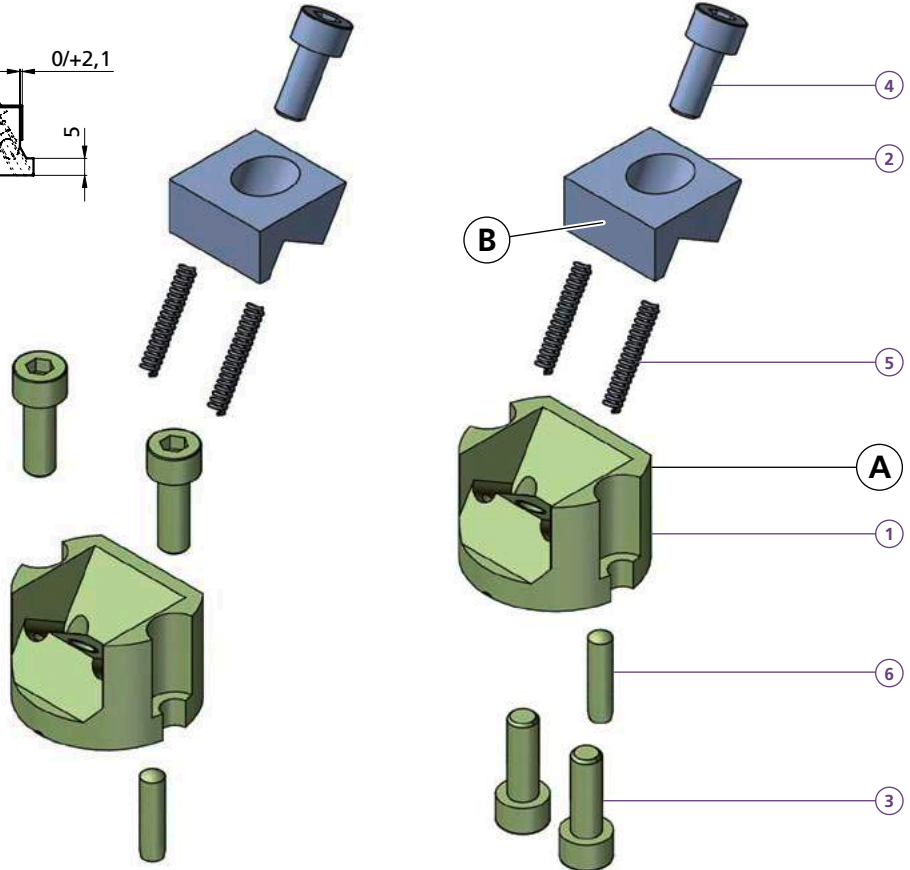

Bestellbeispiel / Ordering example: 1x MR1F30N23-07 & 1x B08

MR1F30N23-07		B07 B08 B09 B09+2 B09+5				
1	1x TF140711					
2	1x					
3	2x M5X16ISO4762					
4	1x M5X12ISO4762					
5	2x FED03018					
6	1x Ø4x14 DIN 6325					
kg	~0,095					
		C	H	L	D	i
		20	20	20	20	20
		10	10	10	10	10
		9,5	9,5	9,5	11,5	14,5
		5,5	5,5	5,5	5,5	5,5
		6	6	6	6	6
		HV700	HV700	*	*	*
		x0,2mm	x0,2mm			
		kg	~0,02	~0,02	~0,02	~0,02

**B07, B08, B09**

**B09+2, B09+5**

Separat bestellen / Separate order





# MS1F22N40-07

microCLAMP

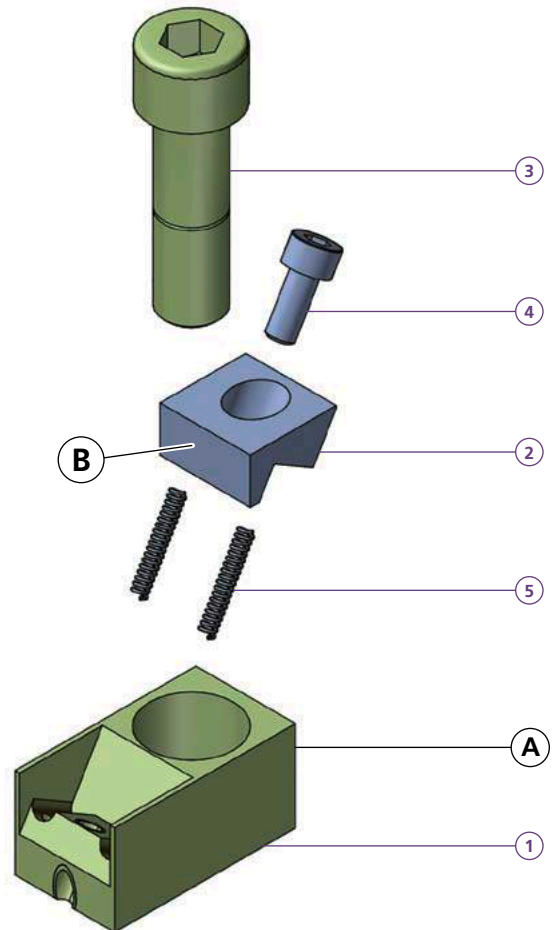
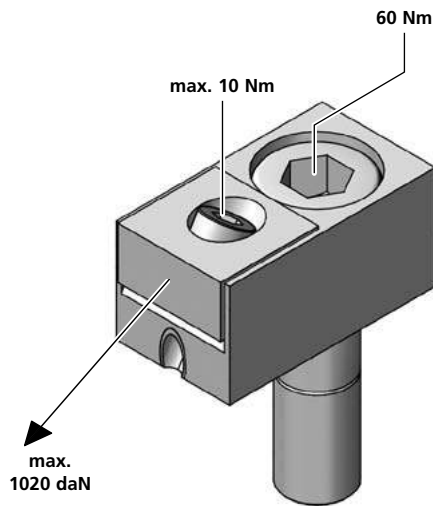
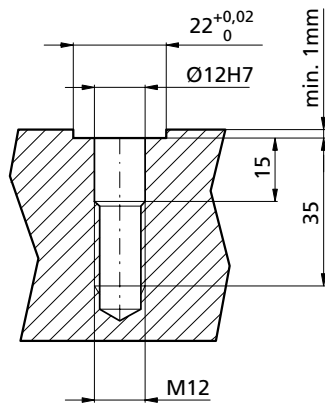
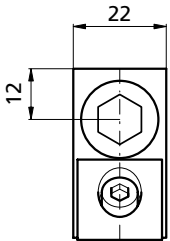
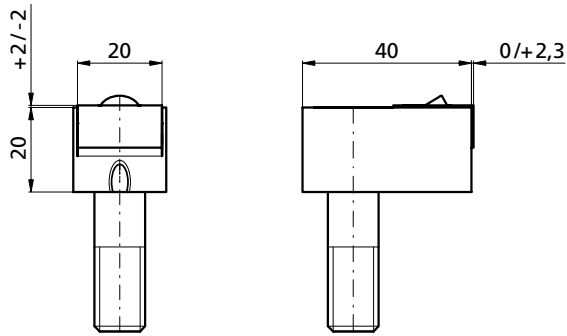

MS1F22N40-07	
1	1x TF140712
2	1x
3	1x TWPAS1240
4	1x M5X12ISO4762
5	2x FED03018
kg	~0,15

	B07	B08	B09	B09+2	B09+5
C	20	20	20	20	20
H	10	10	10	10	10
L	9,5	9,5	9,5	11,5	14,5
D	5,5	5,5	5,5	5,5	5,5
ø	6	6	6	6	6
i	HV700	HV700	*	*	*
	x0,2mm	x0,2mm			
kg	~0,02	~0,02	~0,02	~0,02	~0,02

Bestellbeispiel / Ordering example: 1x MS1F22N40-07 & 1x B08

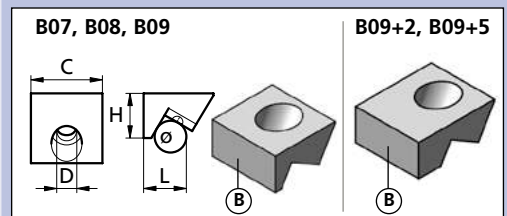

\* = weicher Stahl / soft steel

Separat bestellen / Separate order



# MS1R/F24N22-07

microCLAMP

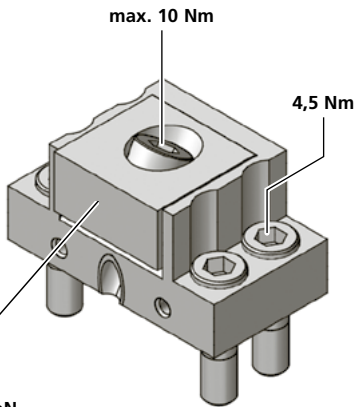
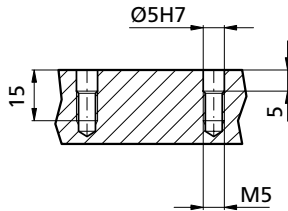
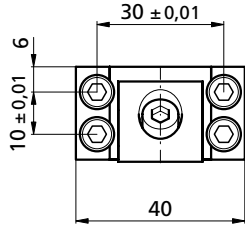
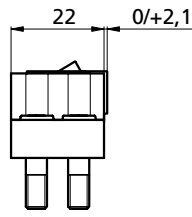
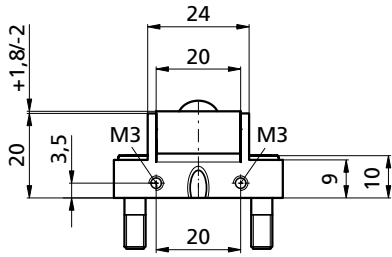

max. 1020 daN

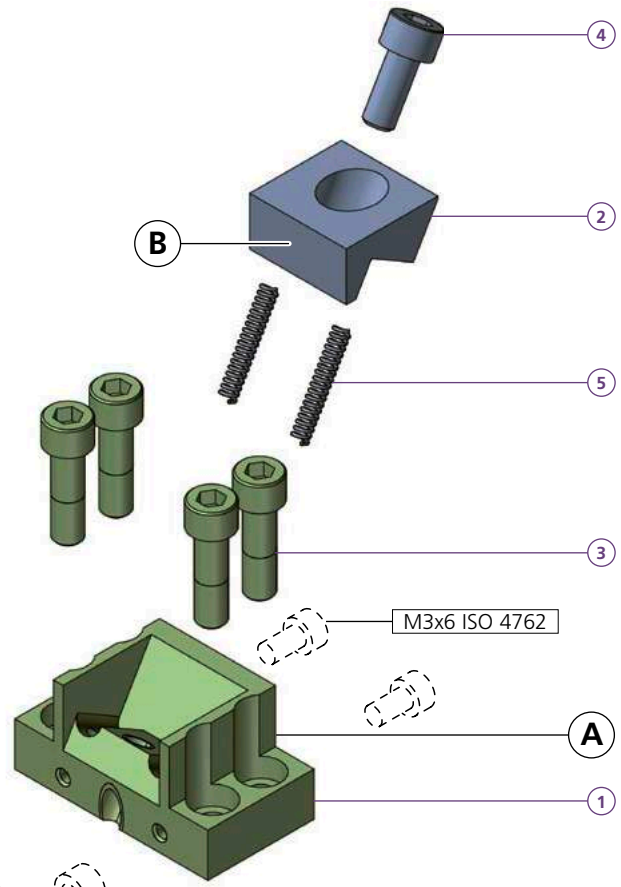
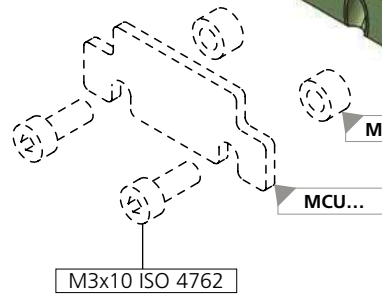

	H	B	N	kg
MCU11037	11	23	2	~0,004
MCU15037	15	23	2	~0,006
MCU18037	18	23	2	~0,008
MCU20037	20	23	2	~0,008
MCU22537	22,5	23	2	~0,008

- 2x M3X10ISO4762
- 2x M3X6ISO4762
- 2x MCD 004

**Achtung:** Bei Spannkraften über 400 daN (0,4t) muss das Spannmodul in eine Nut eingelassen werden (Nuttiefe mindestens 1mm)

**Remark:** Using forces higher than 400 daN, clamps must be mounted into a slot (depth minimum 1mm)

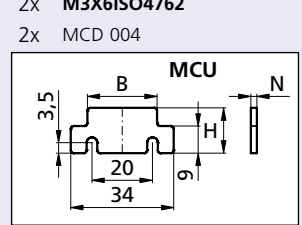
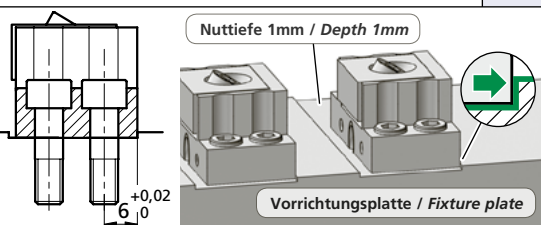

<b>MS1F24N22-07</b>	
1	1x TF140713
<b>MS1R24N22-07</b>	
1	1x TW100172-01
2	1x
3	4x MS50
4	1x M5X12ISO4762
5	2x FED03018
kg	~0,125

	B07	B08	B09	B09+2	B09+5
C	20	20	20	20	20
H	10	10	10	10	10
L	9,5	9,5	9,5	11,5	14,5
D	5,5	5,5	5,5	5,5	5,5
ø	6	6	6	6	6
i	HV700	HV700	*	*	*
	x0,2mm	x0,2mm			
kg	~0,02	~0,02	~0,02	~0,02	~0,02

Bestellbeispiel / Ordering example: 1x MS1F24N22-07 & 1x B08

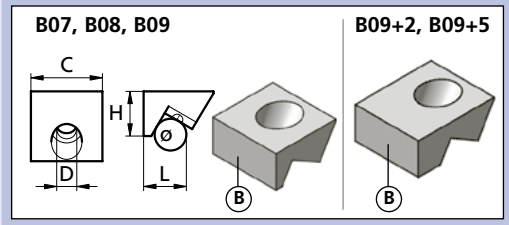

Separat bestellen / Separate order



# MS1R/F25N25-13

microCLAMP

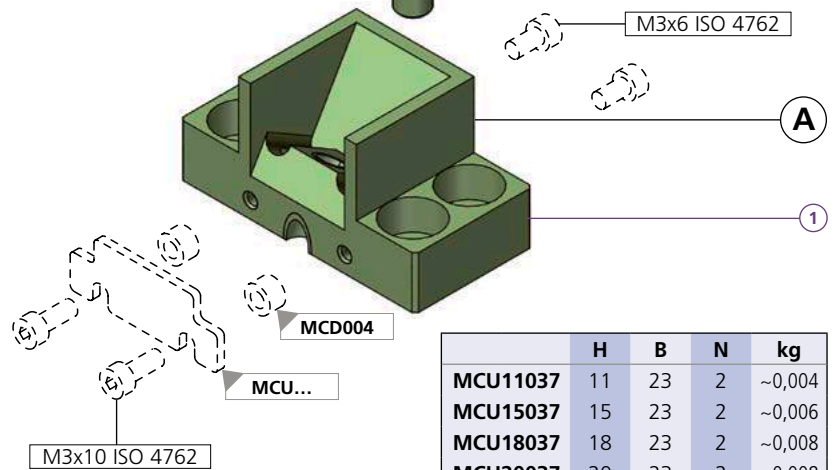
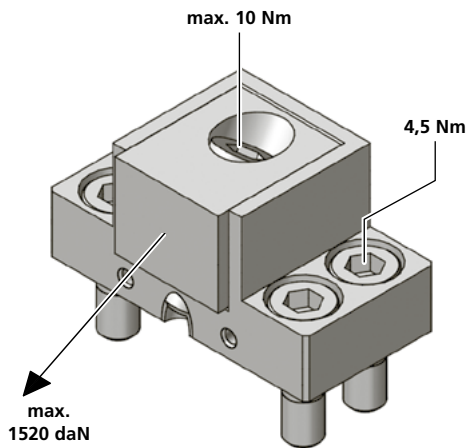
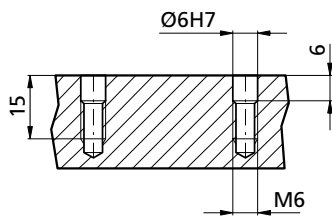
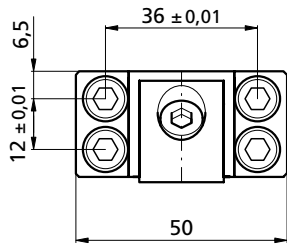
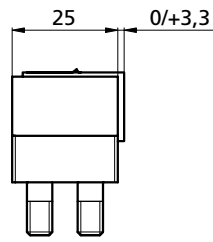
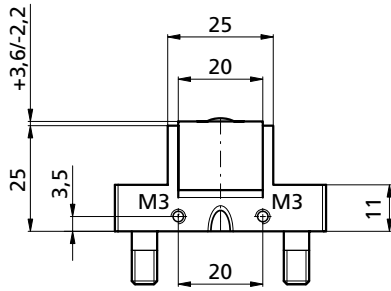

	H	B	N	kg
MCU11037	11	23	2	~0,004
MCU15037	15	23	2	~0,006
MCU18037	18	23	2	~0,008
MCU20037	20	23	2	~0,008
MCU22537	22,5	23	2	~0,008

- 2x M3X10ISO4762
- 2x M3X6ISO4762
- 2x MCD 004

**Achtung:** Bei Spannkraften über 400 daN (0,4t) muss das Spannmodul in eine Nut eingelassen werden (Nuttiefe mindestens 1mm)

**Remark:** Using forces higher than 400 daN, clamps must be mounted into a slot (depth minimum 1mm)

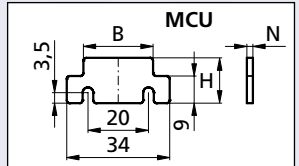
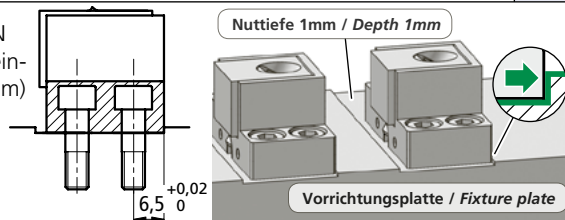

MS1F25N25-13	
1	1x TF140714
MS1R25N25-13	
1	1x TF140715
2	1x
3	4x MS60
4	1x M6X16ISO4762
5	2x FED03018
kg	~0,165

Bestellbeispiel / Ordering example: 1x MS1F25N25-13 & 1x B14

	B13	B14	B15	B16
C	20	20	20	20
H	16	16	16	16
L	13,8	13,8	13,8	19
D	6,5	6,5	6,5	6,5
ø	10	10	10	10
i	HV700	HV700	*	*
	x0,2mm	x0,2mm		
kg	~0,05	~0,05	~0,05	~0,06

\* = weicher Stahl / soft steel

Separat bestellen / Separate order



# MS1R/F35N14-01

# MS1F35N22-01

microCLAMP

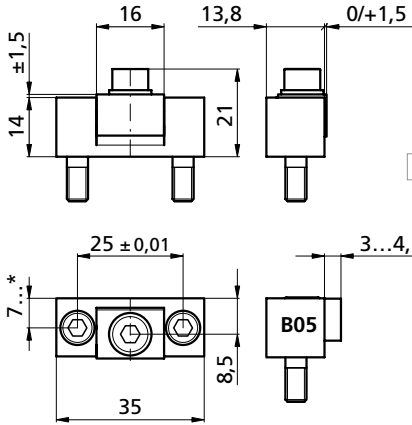

MS1F35N14-01

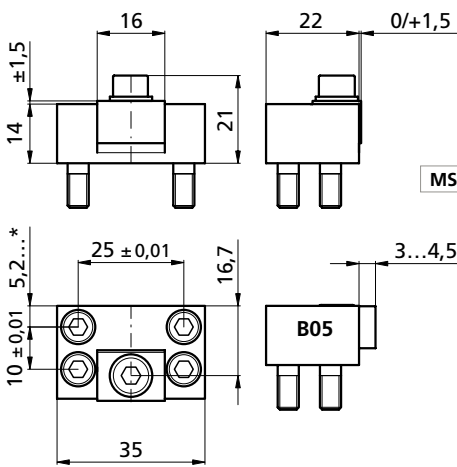
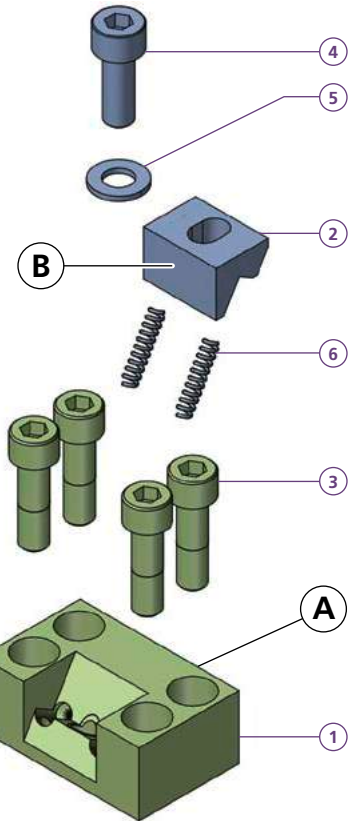
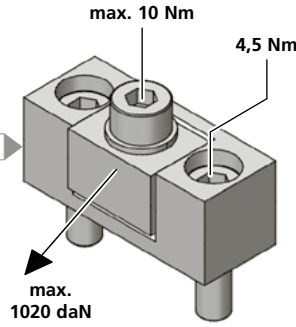

MS1F35N22-01

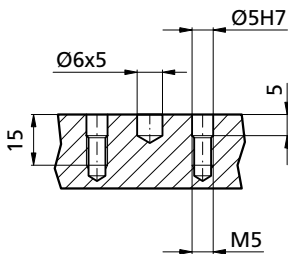
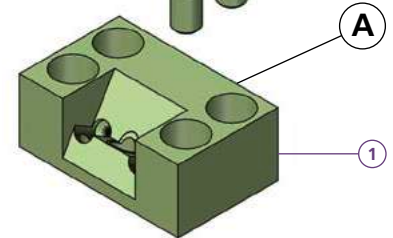
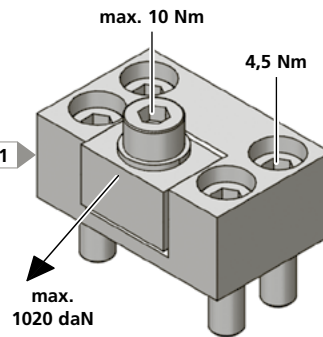

**Beim Einsatz der Backe B05(R) Jaw B05(R) in use**  
 Nachbearbeitung am Modul, falls If a stroke of 1,1mm to 1,5mm der gesamte Backenhub (1,1mm bis is required the module must be 1,5mm) benötigt wird. machined according to this sketch.

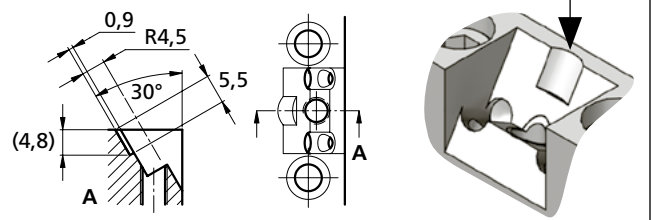

**Achtung:** Bei Spannkraften über 400 daN (0,4t) muss das Spannmodul in eine Nut eingelassen werden (Nuttiefe mindestens 1mm)

**Remark:** Using forces higher than 400 daN, clamps must be mounted into a slot (depth minimum 1mm)

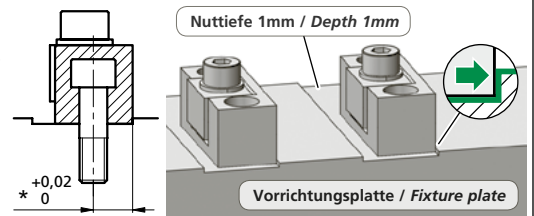

<b>MS1F35N14-01</b>	<b>A</b>
1x TF140718	
<b>MS1R35N14-01</b>	<b>B</b>
1x TK190150	
1x	
2x MS50	
1x M5X14ISO4762	
1x 5x10x1DIN125A	
2x FED02813	
kg ~0,05	
<b>MS1F35N22-01</b>	<b>A</b>
1x TF140719	
4x MS50	
kg ~0,08	

Bestellbeispiel / Ordering example: 1x MS1F35N14-01 & 1x B02

	B01	B02	B03	B04	B05	B05R
C	16	16	16	16	16	16
H	10	10	10	10	10	10
L	8	8	11	8	10	10
D	5,5	5,5	5,5	5,5	5,2	5,2
ø	4	4	4	4	4	4
i	HV700	HV700	*	Messing	HV700	HV700
	x0,2mm	x0,2mm		Laiton	x0,2mm	x0,2mm
kg	~0,01	~0,01	~0,014	~0,012	~0,014	~0,014

M5X10DIN6912



# MS2X35N23-01

microCLAMP

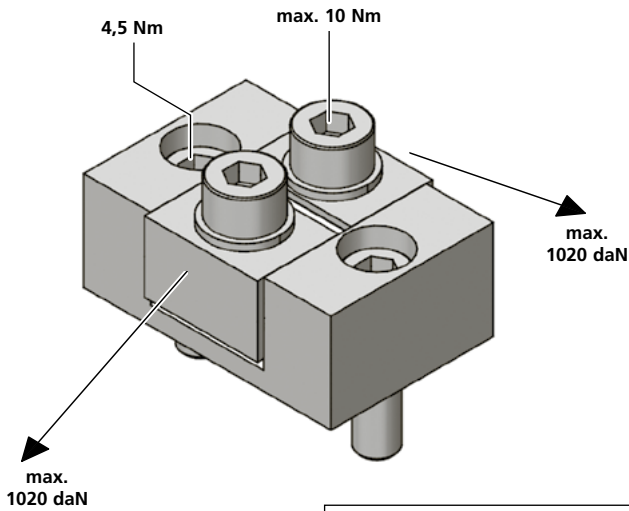
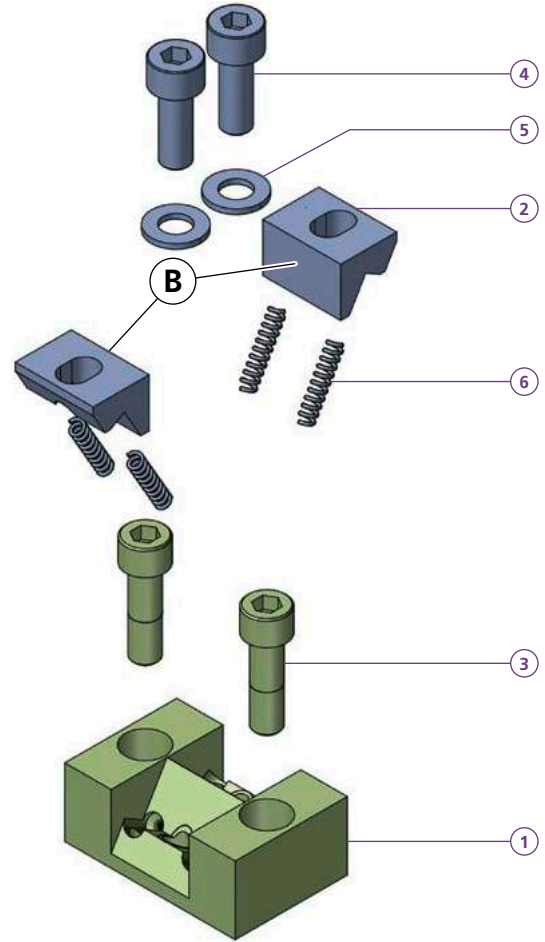
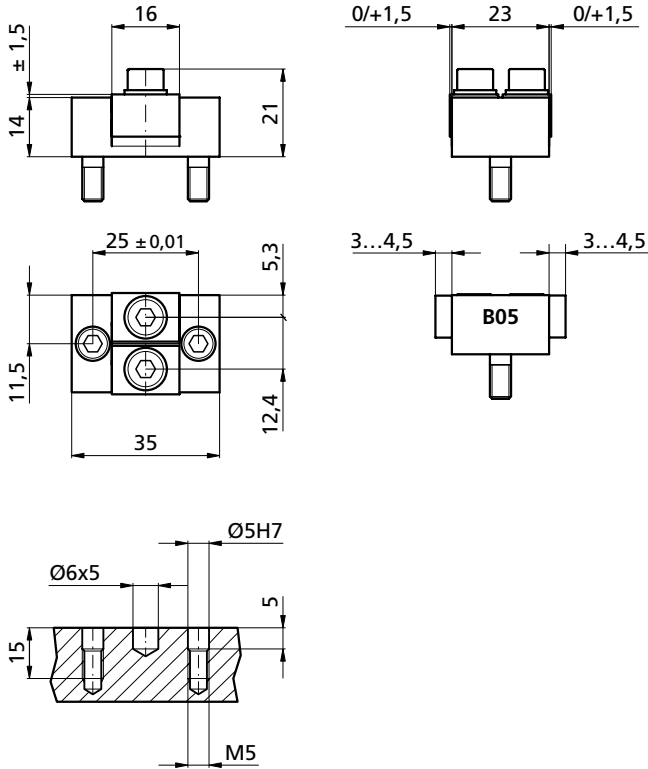

**Beim Einsatz der Backe B05(R) Jaw B05(R) in use**  
 Nachbearbeitung am Modul, falls If a stroke of 1,1mm to 1,5mm der gesamte Backenhub (1,1mm bis is required the module must be 1,5mm) benötigt wird. machined according to this sketch.

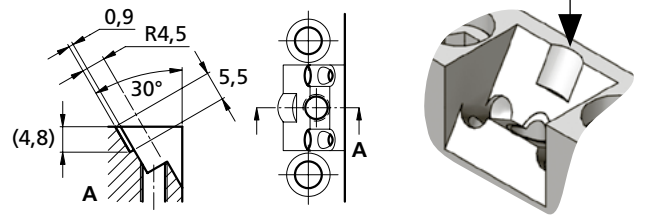

**Achtung:** Bei Spannkraften über 400 daN (0,4t) muss das Spannmodul in eine Nut eingelassen werden (Nuttiefe mindestens 1mm)

**Remark:** Using forces higher than 400 daN, clamps must be mounted into a slot (depth minimum 1mm)

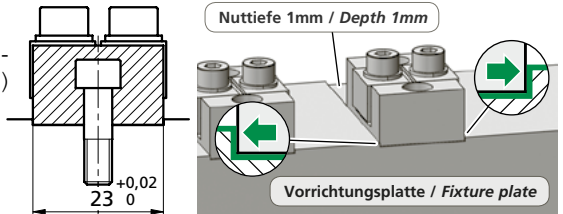

**Bestellbeispiel / Ordering example: 1x MS2X35N23-01 & 2x B02**

MS2X35N23-01		B01	B02	B03	B04	B05	B05R
①	1x TF140720						
②	2x						
③	2x MS50						
④	2x M5X14ISO4762						
⑤	2x 5x10x1DIN125A						
⑥	4x FED02813						
kg	~0,085						
		kg	kg	kg	kg	kg	kg
		~0,01	~0,01	~0,014	~0,012	~0,014	~0,014

	B01	B02	B03	B04	B05	B05R
C	16	16	16	16	16	16
H	10	10	10	10	10	10
L	8	8	11	8	10	10
D	5,5	5,5	5,5	5,5	5,2	5,2
ø	4	4	4	4	4	4
i	HV700	HV700	*	Messing	HV700	HV700
	x0,2mm	x0,2mm		Laiton	x0,2mm	x0,2mm

**M5X10DIN6912**

\* = weicher Stahl / soft steel

Separat bestellen / Separate order



# MS2F60N14-01

microCLAMP

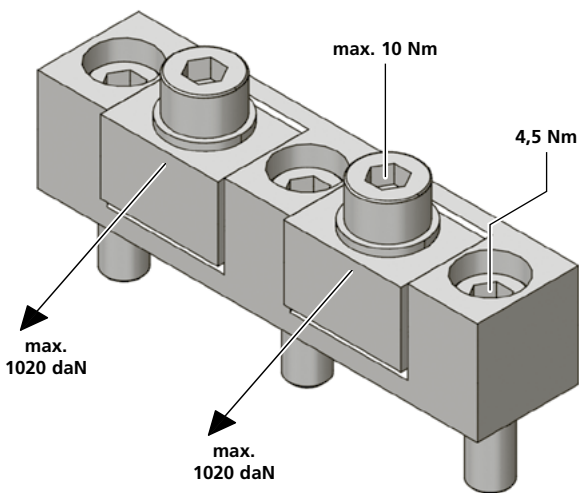
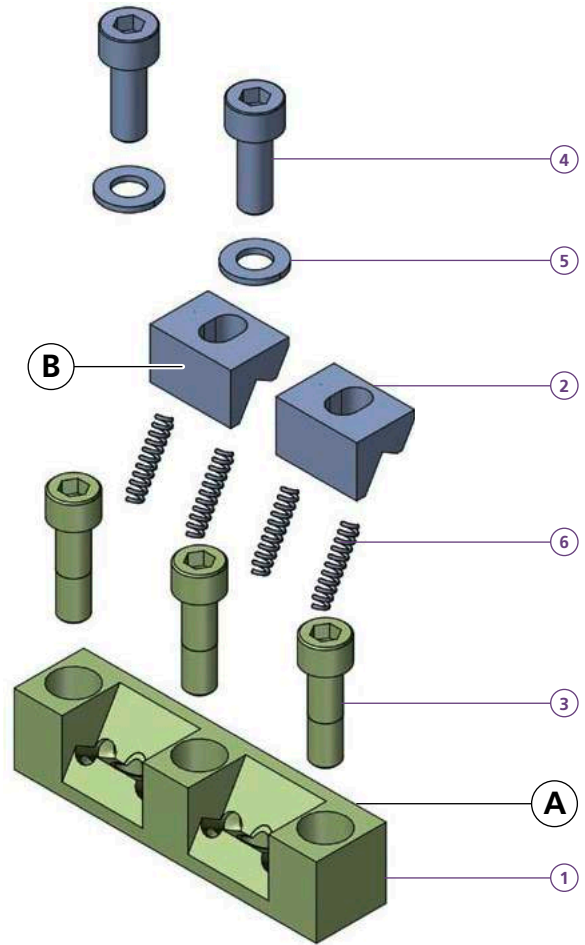
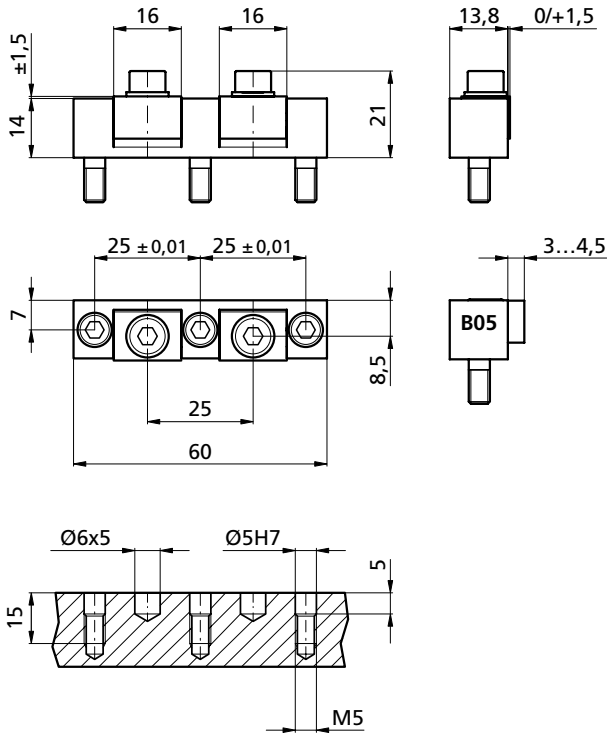

**Beim Einsatz der Backe B05(R) Jaw B05(R) in use**  
 Nachbearbeitung am Modul, falls If a stroke of 1,1mm to 1,5mm  
 der gesamte Backenhub (1,1mm bis is required the module must be  
 1,5mm) benötigt wird. machined according to this sketch.

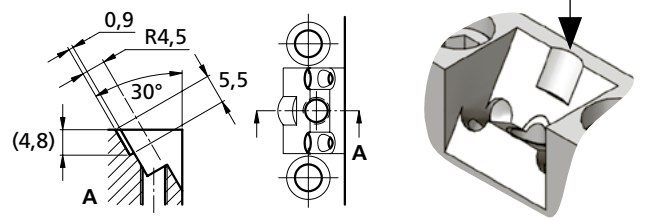

**Achtung:** Bei Spannkraften über 400 daN (0,4t) muss das Spannmodul in eine Nut eingelassen werden (Nuttiefe mindestens 1mm)  
**Remark:** Using forces higher than 400 daN, clamps must be mounted into a slot (depth minimum 1mm)

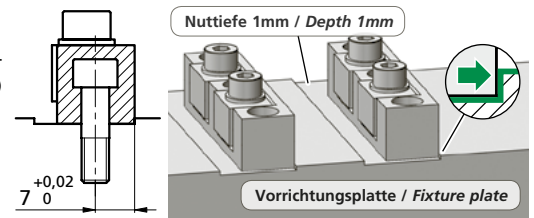

MS2F60N14-01		Bestellbeispiel / Ordering example: 1x MS2F60N14-01 & 2x B02						
1	1x TF140721	B01	B02	B03	B04	B05	B05R	M5X10DIN6912
2	2x							
3	3x MS50							
4	2x M5X14ISO4762							
5	2x 5x10x1DIN125A							
6	4x FED02813							
kg	~0,09	kg	~0,01	~0,01	~0,014	~0,012	~0,014	~0,014

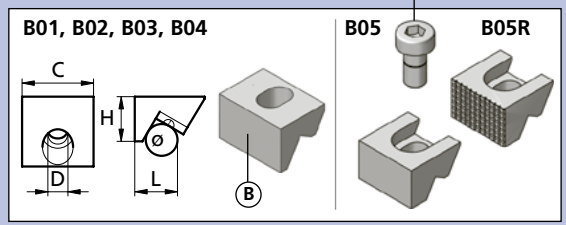

Separat bestellen / Separate order



# MS3F85N14-01

microCLAMP

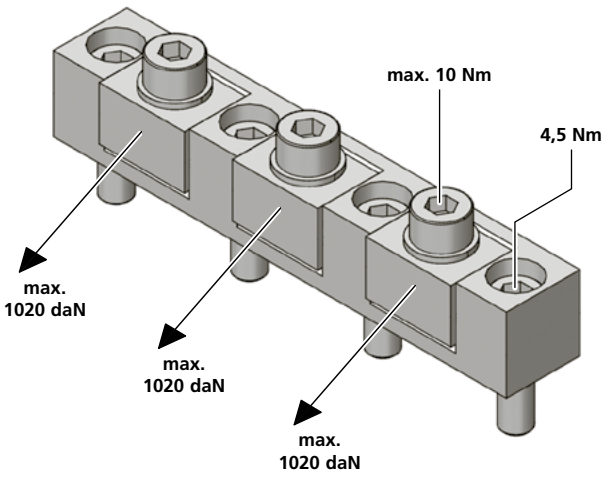
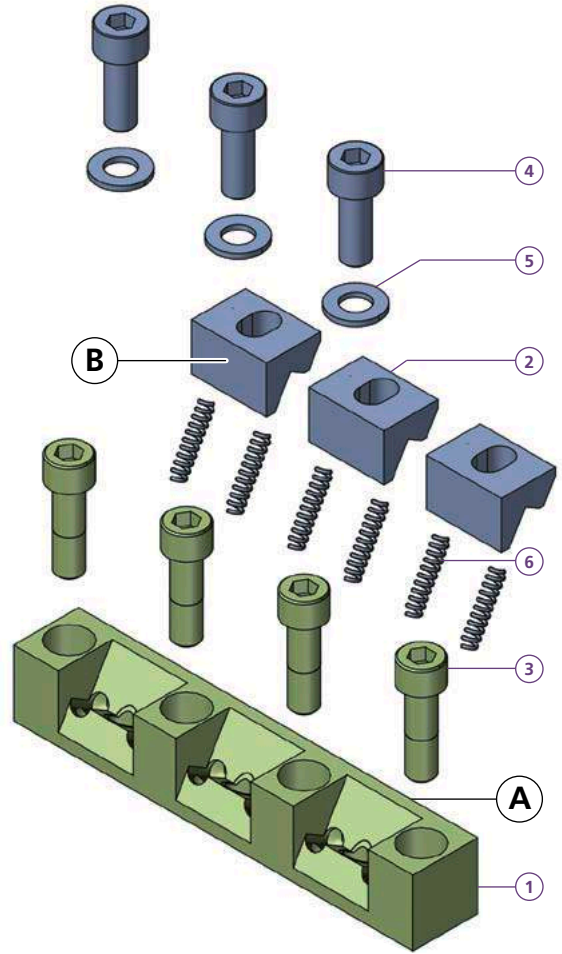
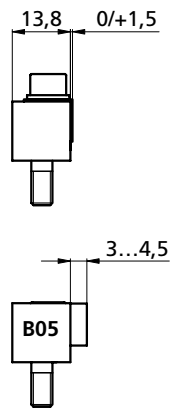
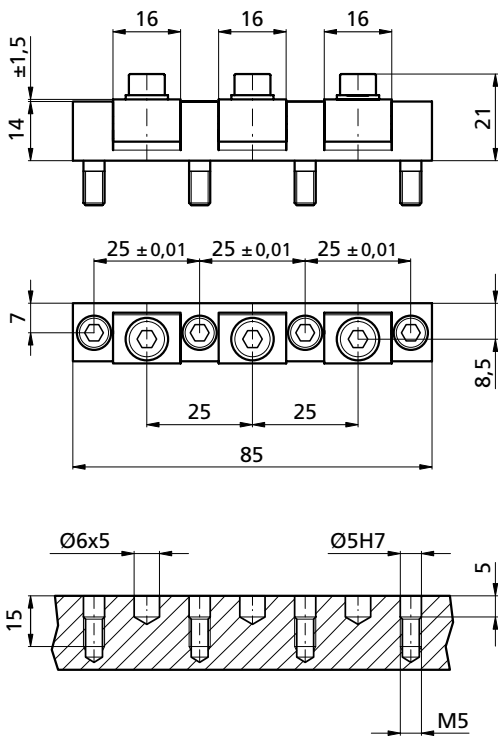

**Beim Einsatz der Backe B05(R) Jaw B05(R) in use**  
 Nachbearbeitung am Modul, falls If a stroke of 1,1mm to 1,5mm  
 der gesamte Backenhub (1,1mm bis is required the module must be  
 1,5mm) benötigt wird. machined according to this sketch.

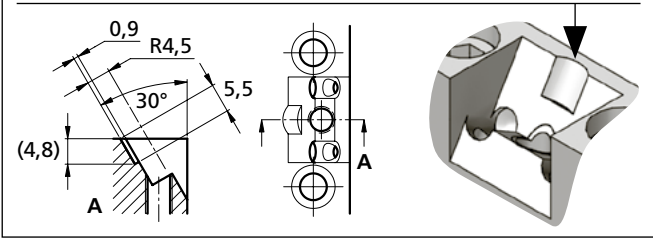

**Achtung:** Bei Spannkraften über 400 daN (0,4t) muss das Spannmodul in eine Nut eingelassen werden (Nuttiefe mindestens 1mm)  
**Remark:** Using forces higher than 400 daN, clamps must be mounted into a slot (depth minimum 1mm)

Bestellbeispiel / Ordering example: 1x MS3F85N14-01 & 3x B02

MS3F85N14-01	B01	B02	B03	B04	B05	B05R
1x TH160579						
3x						
4x MS50						
3x M5X14ISO4762						
3x 5x10x1DIN125A						
6x FED02813						
kg ~0,125	kg ~0,01	kg ~0,01	kg ~0,014	kg ~0,012	kg ~0,014	kg ~0,014

	C	H	L	D	ø	i
B01	16	10	8	5,5	4	HV700
B02	16	10	8	5,5	4	HV700
B03	16	10	11	5,5	4	*
B04	16	10	8	5,5	4	Messing Laiton
B05	16	10	10	5,2	4	HV700
B05R	16	10	10	5,2	4	HV700

M5X10DIN6912

\* = weicher Stahl / soft steel

Separat bestellen / Separate order



# VS1R/F19N35-20

microCLAMP

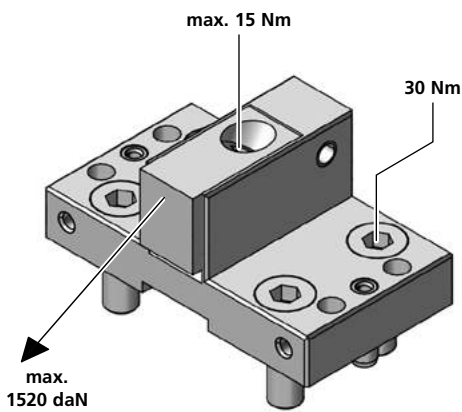
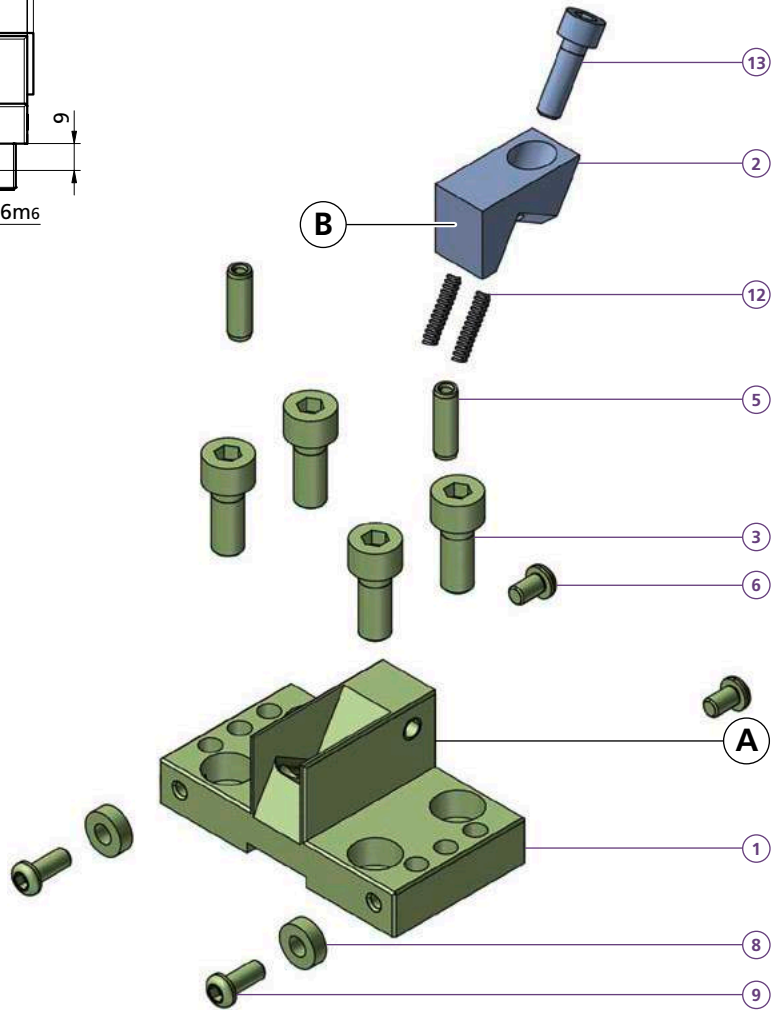
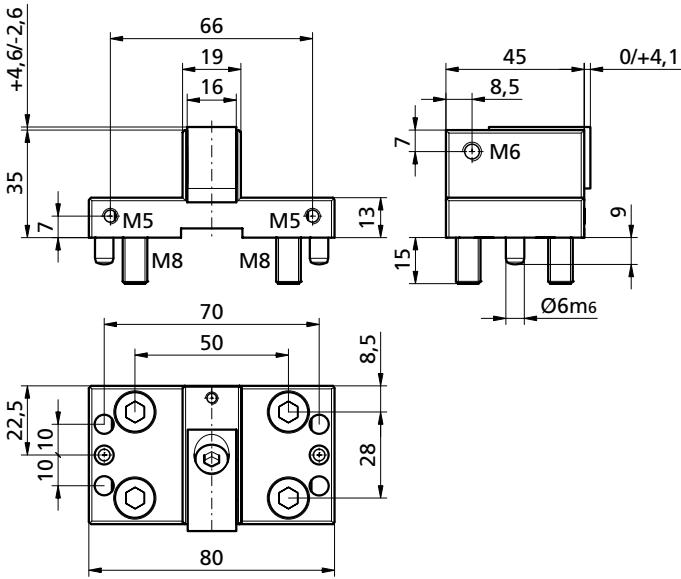

	<b>A</b>
<b>VS1F19N35-20</b>	
<b>1</b>	1x TF150029
<b>VS1R19N35-20</b>	
<b>1</b>	1x TF140723
<b>2</b>	1x
<b>3</b>	4x M8X20ISO4762
<b>5</b>	2x CCBO0802
<b>6</b>	2x M5X8ISO7380
<b>8</b>	2x CCD004
<b>9</b>	2x M5X12ISO7380
<b>12</b>	2x FED0418
<b>13</b>	1x M6X20ISO4762
<b>kg</b>	~0,505

**B** Bestellbeispiel / Ordering example: 1x VS1R19N35-20 & 1x B21

	B20	B21	B22
<b>C</b>	16	16	16
<b>H</b>	20	20	20
<b>L</b>	19	19	19
<b>D</b>	6,5	6,5	6,5
<b>ø</b>	12	12	12
<b>i</b>	HV700	HV700	*
	x0,2mm	x0,2mm	
<b>kg</b>	~0,011	~0,011	~0,011

**B20, B21, B22**

Separat bestellen / Separate order





# VS1R26N35-26

microCLAMP

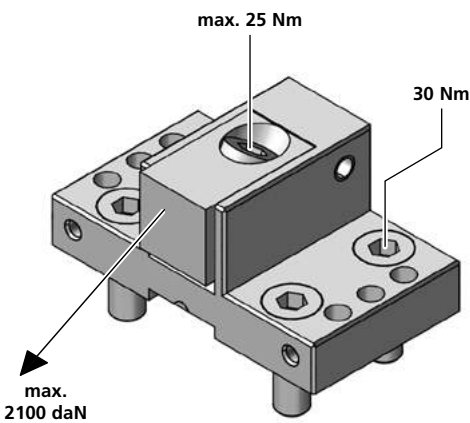
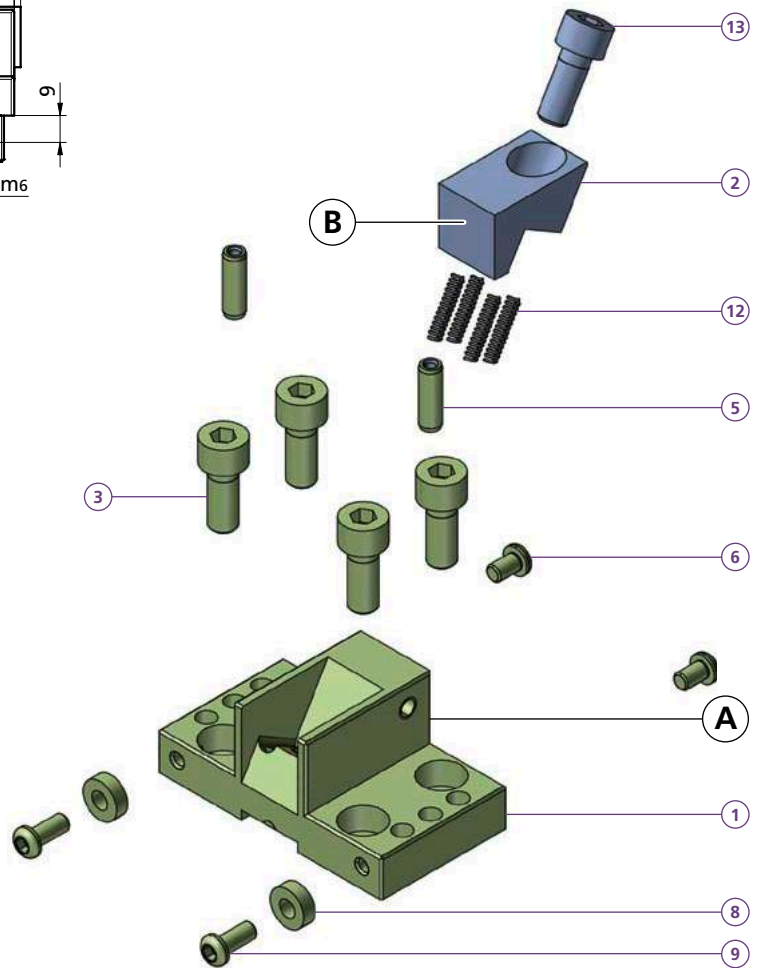
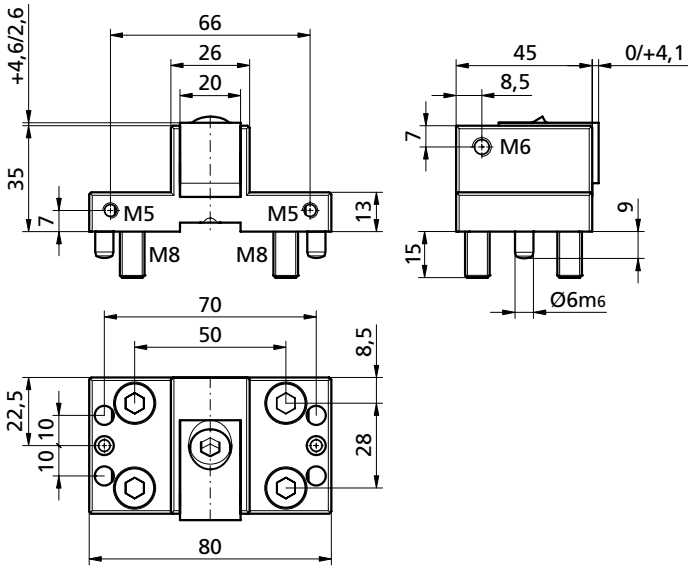

VS1R26N35-26	
1	1x TF140725
2	1x
3	4x M8X20ISO4762
5	2x CCBO0802
6	2x M5X8ISO7380
8	2x CCD004
9	2x M5X12ISO7380
12	4x FED0418
13	1x M8X20ISO4762
kg	~0,55

Bestellbeispiel / Ordering example: 1x VS1R26N35-26 & 1x B27

	B26	B27	B28
C	20	20	20
H	20	20	20
L	19	19	19
D	9	9	9
ø	12	12	12
i	HV700	HV700	*
	x0,2mm	x0,2mm	
kg	~0,064	~0,064	~0,064

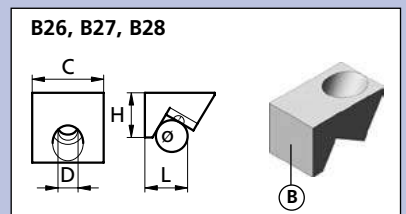

\* = weicher Stahl / soft steel

Separat bestellen / Separate order



# VS1R38N50-60

microCLAMP

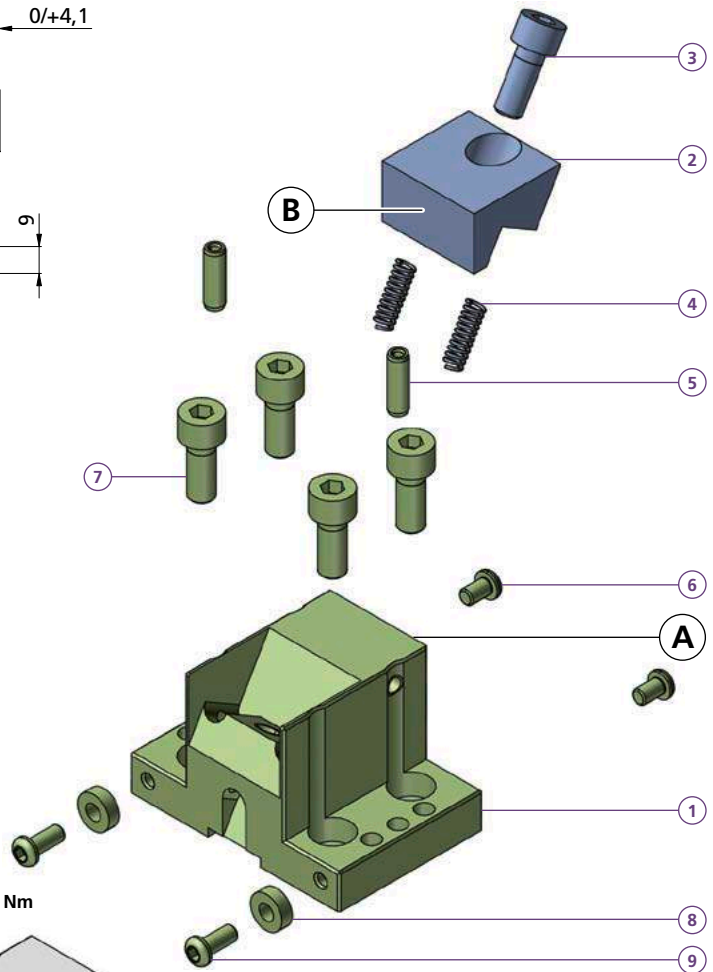
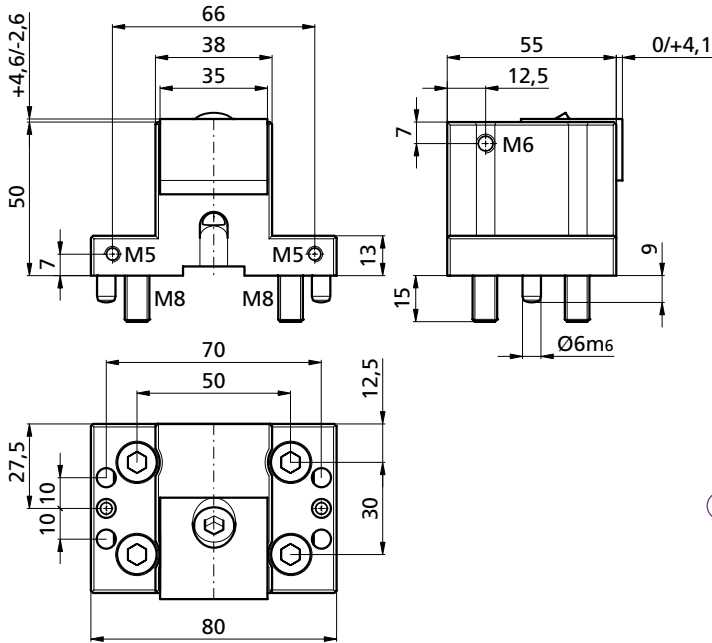

**VS1R38N50-60**

1	1x	TF140726
2	1x	
3	1x	M8X20ISO4762
4	2x	FED0618
5	2x	CCBO0802
6	2x	M5X8ISO7380
7	4x	M8X20ISO4762
8	2x	CCD004
9	2x	M5X12ISO7380
kg		~1,01

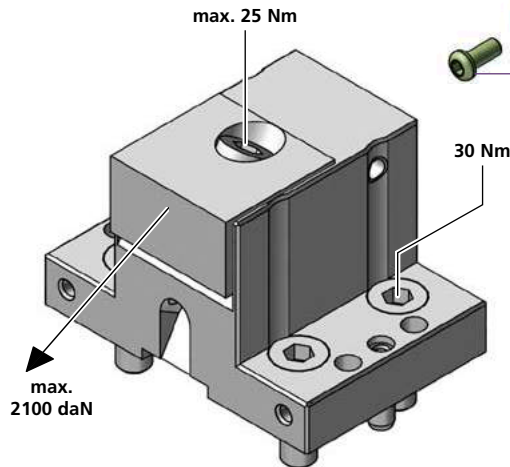

Bestellbeispiel / Ordering example: 1x VS1R38N50-60 & 1x B61

	B58	B60	B61	B62	B62HM	B65	B66	B67	B68	B69	B77	B79F	B79R
C	35	35	35	35	35	35	35	35	35	35	35	35	35
H	20	20	20	20	20	20	20	20	20	25	20	20	20
L	26	19	19	19	19	19	19	24	26	22	22	25	25
D	9	9	9	9	9	9	9	9	9	9	9	9	9
ø	12	12	12	12	12	12	12	12	12	12	12	12	12
i	ALU	56HRC	56HRC	*	HM	HV700	HV700	HV700	*	*	56HRC	HV700	HV700
						x0,2mm	x0,2mm	x0,2mm				x0,2mm	x0,2mm
kg	~0,07	~0,12	~0,12	~0,12	~0,12	~0,12	~0,12	~0,14	~0,15	~0,15	~0,12	~0,18	~0,18

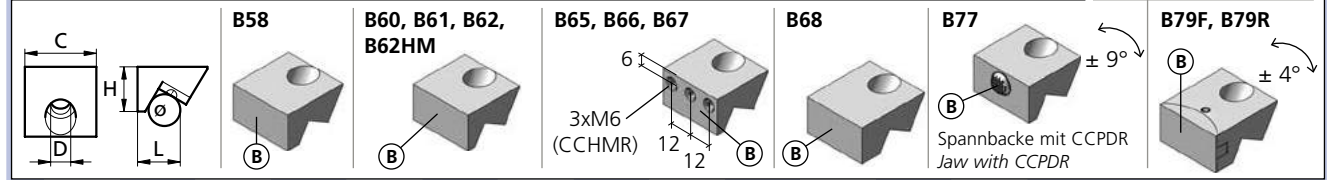
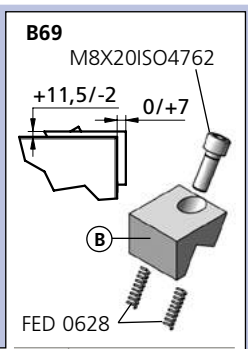



# VS1R/F41N30-60

microCLAMP

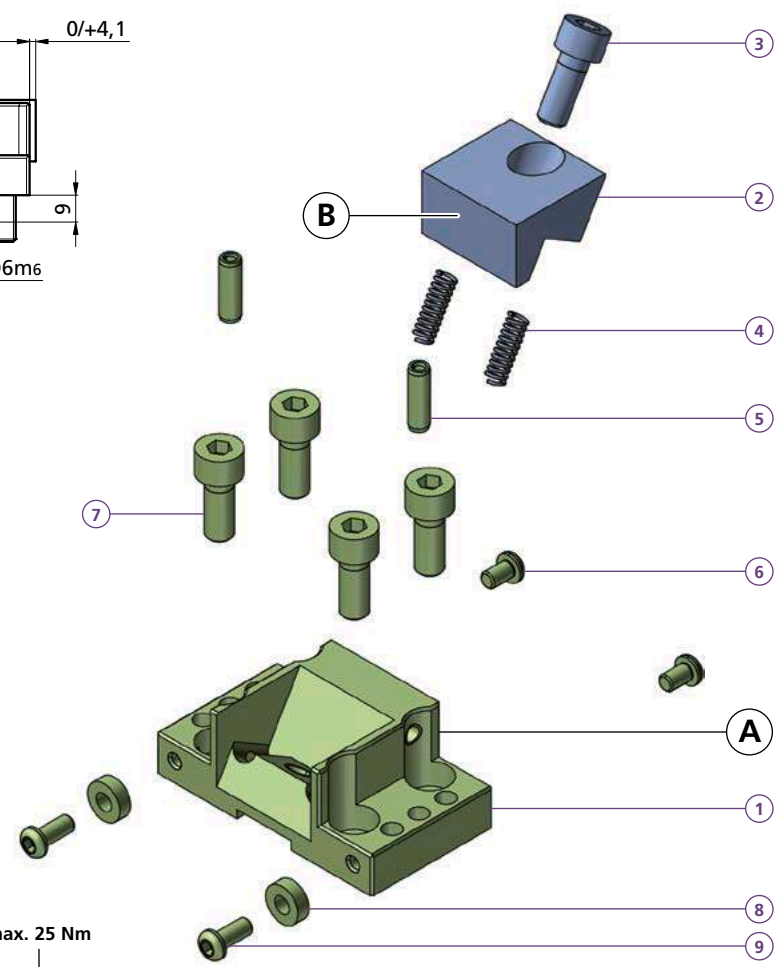
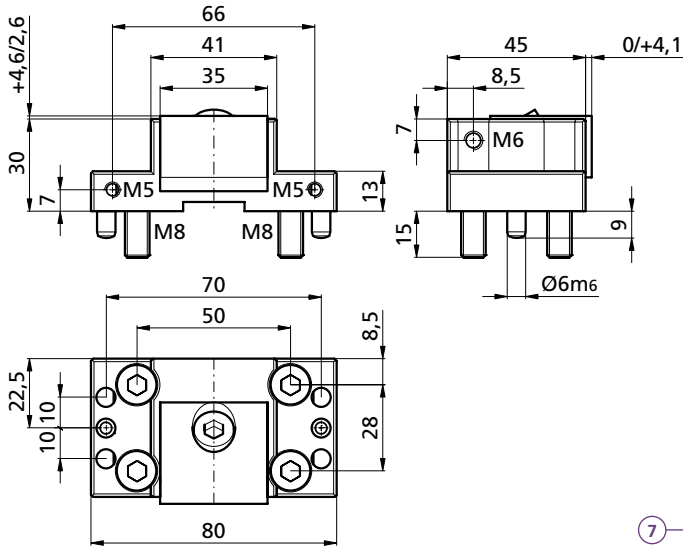

- VS1F41N30-60**
- 1x TF140729
- VS1R41N30-60**
- 1x TF140730
- 1x
- 1x M8X20ISO4762
- 2x FED0618
- 2x CCBO0802
- 2x M5X8ISO7380
- 4x M8X20ISO4762
- 2x CCD004
- 2x M5X12ISO7380
- kg ~0,58

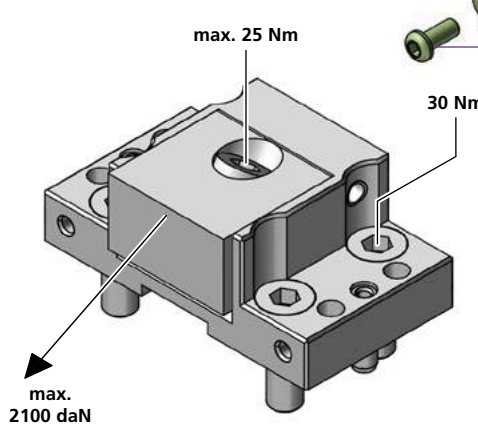

Bestellbeispiel / Ordering example: 1x VS1R41N30-60 & 1x B61

	B58	B60	B61	B62	B62HM	B65	B66	B67	B68	B69	B77	B79F	B79R
C	35	35	35	35	35	35	35	35	35	35	35	35	35
H	20	20	20	20	20	20	20	20	20	25	20	20	20
L	26	19	19	19	19	19	19	24	26	22	22	25	25
D	9	9	9	9	9	9	9	9	9	9	9	9	9
ø	12	12	12	12	12	12	12	12	12	12	12	12	12
i	ALU	56HRC	56HRC	*	HM	HV700	HV700	HV700	*	*	56HRC	HV700	HV700
		x0,2mm	x0,2mm	x0,2mm								x0,2mm	x0,2mm
kg	~0,07	~0,12	~0,12	~0,12	~0,12	~0,12	~0,12	~0,14	~0,15	~0,15	~0,12	~0,18	~0,18

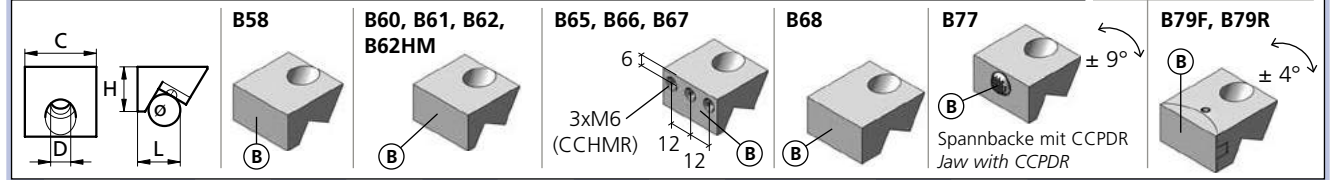
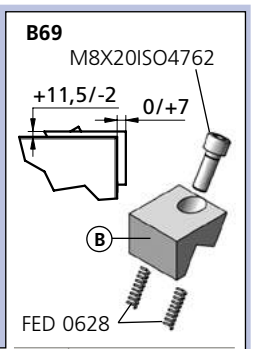

\* = weicher Stahl / soft steel      HM = Hartmetallbeschichtet / Carbide coated      ALU = ENAW-7022

Separat bestellen / Separate order



# VS1R/F80N30-36

# VS1R80N50-36

microCLAMP

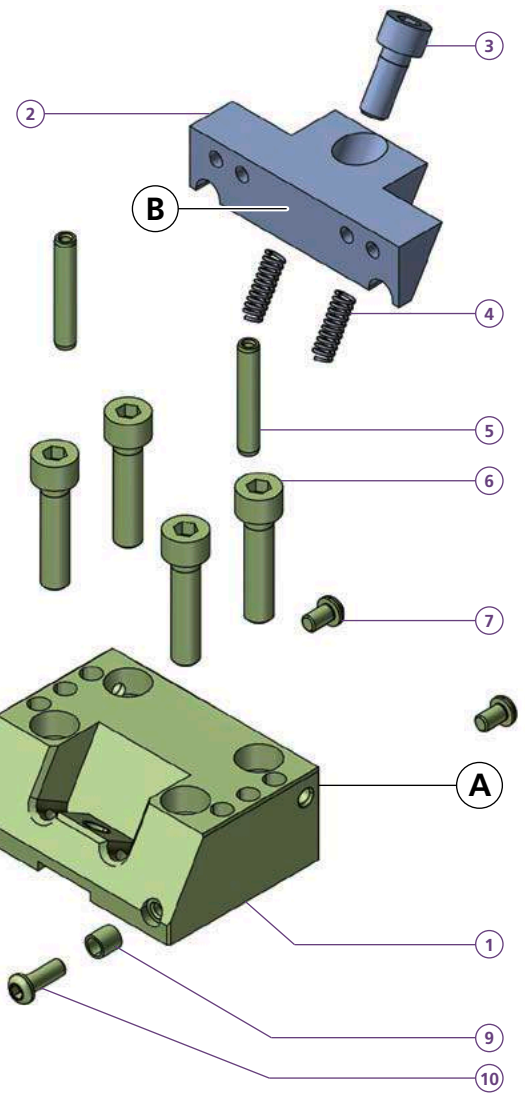
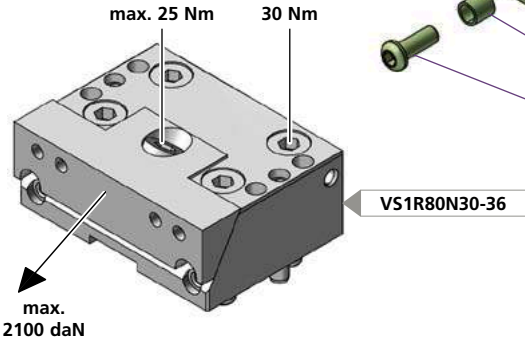
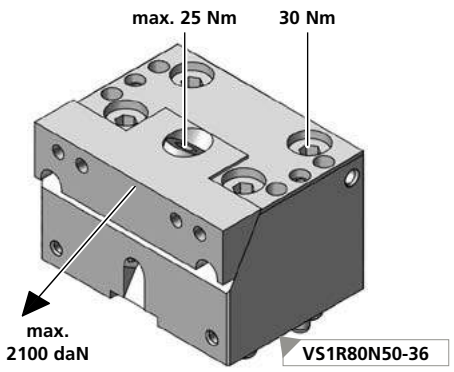
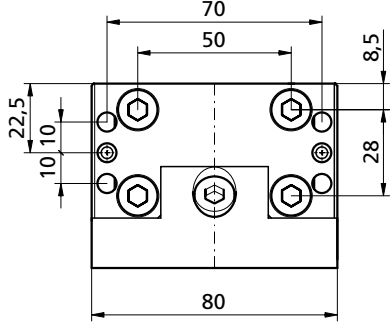
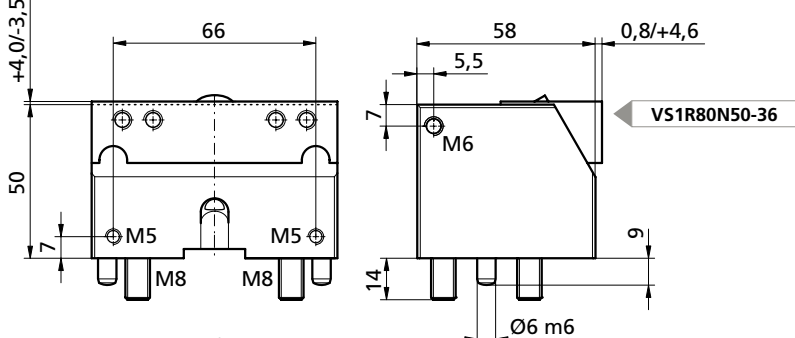
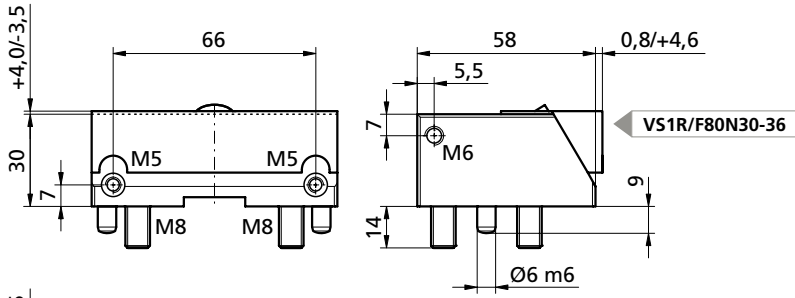

<b>VS1F80N30-36</b>		<b>VS1R80N50-36</b>	
1	1x TF140733	1	1x TF140742
<b>VS1R80N30-36</b>		2	1x _____
1	1x TF140734	5	2x CCBO0803
2	1x _____	6	4x M8X55ISO4762
3	1x M8X20ISO4762	9	2x CCD005
4	4x FED0618	10	2x M5X12ISO7380
5	2x CCBO0801	kg	~1,9
6	4x M8X35ISO4762		
7	2x M5X8ISO4762		
9	2x CCD007		
10	2x M5X16ISO7380		
kg	~1,2		

Bestellbeispiel / Ordering example: 1x VS1R80N30-36 & 1x B37

	B36	B37	B38
C	80	80	80
H	20	20	20
L	19	19	19
D	9	9	9
ø	12	12	12
i	HV700	HV700	*
	x0,2mm	x0,2mm	
kg	~0,18	~0,18	~0,18

**B36, B37, B38**

Separat bestellen / Separate order



# VS1R/F80N30-60

microCLAMP

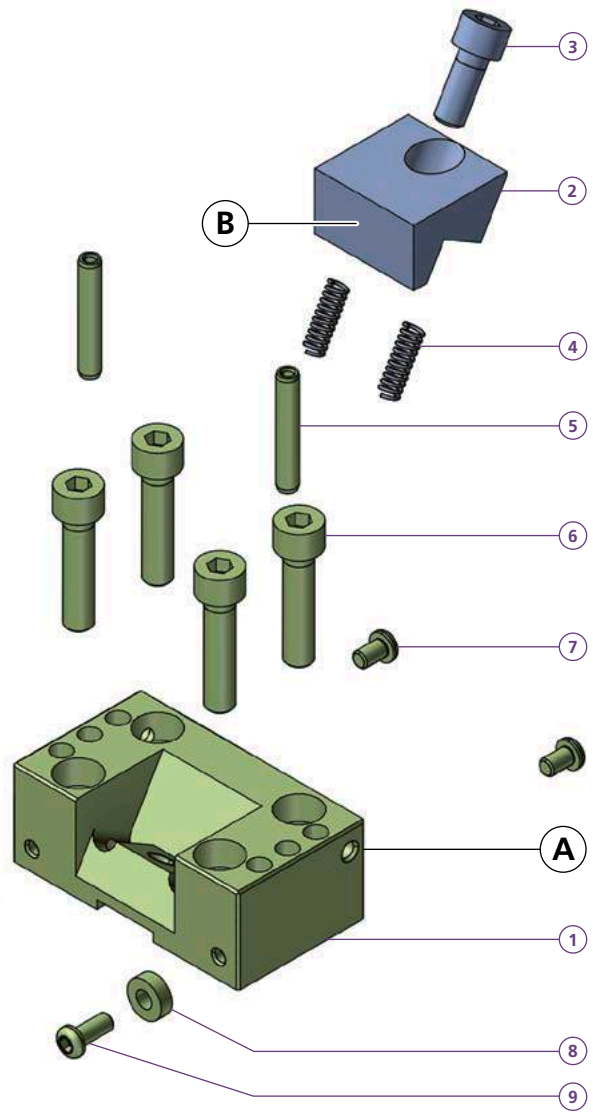
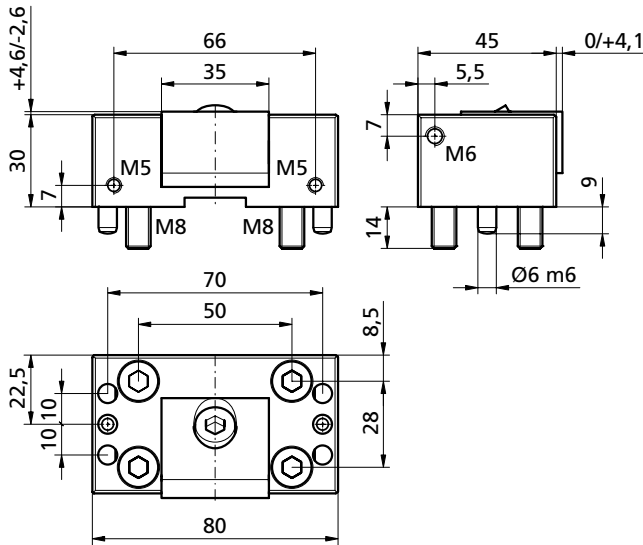

- VS1F80N30-60**
- 1 1x TF140735
- VS1R80N30-60**
- 1 1x TF140736
  - 2 1x
  - 3 1x M8X20ISO4762
  - 4 2x FED0618
  - 5 2x CCBO0801
  - 6 4x M8X35ISO4762
  - 7 2x M5X8ISO7380
  - 8 2x CCD004
  - 9 2x M5X12ISO7380
  - kg ~0,74

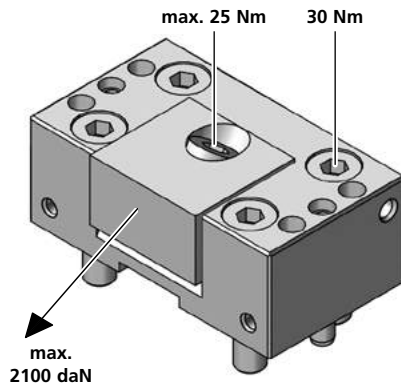

Bestellbeispiel / Ordering example: 1x VS1F80N30-60 & 1x B61

	B58	B60	B61	B62	B62HM	B65	B66	B67	B68	B69	B77	B79F	B79R
C	35	35	35	35	35	35	35	35	35	35	35	35	35
H	20	20	20	20	20	20	20	20	20	25	20	20	20
L	26	19	19	19	19	19	19	24	26	22	22	25	25
D	9	9	9	9	9	9	9	9	9	9	9	9	9
o	12	12	12	12	12	12	12	12	12	12	12	12	12
i	ALU	56HRC	56HRC	*	HM	HV700	HV700	HV700	*	*	56HRC	HV700	HV700
		x0,2mm	x0,2mm	x0,2mm								x0,2mm	x0,2mm
kg	~0,07	~0,12	~0,12	~0,12	~0,12	~0,12	~0,12	~0,14	~0,15	~0,15	~0,12	~0,18	~0,18

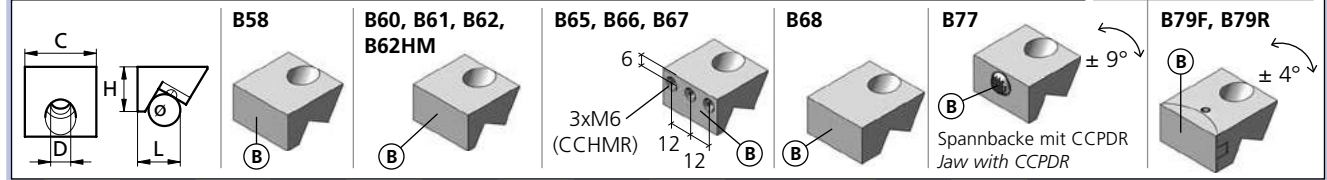
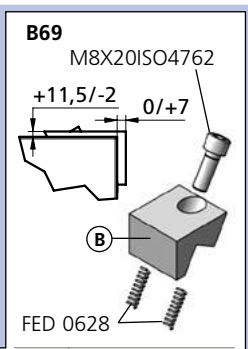

\* = weicher Stahl / soft steel      HM = Hartmetallbeschichtet / Carbide coated      ALU = ENAW-7022

Separat bestellen / Separate order



# VS1R80N50-60

microCLAMP

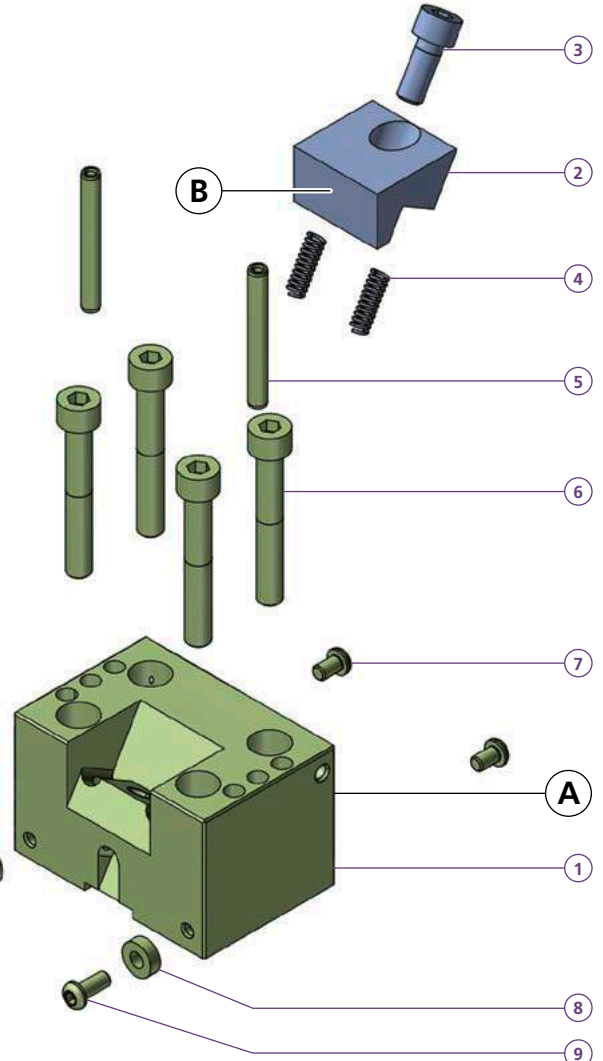
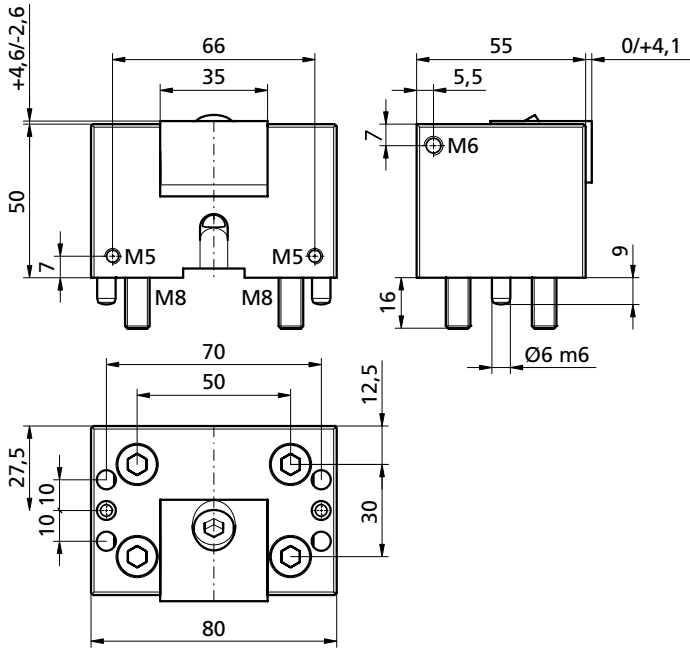

- VS1R80N50-60**
- 1 1x TF140737
  - 2 1x
  - 3 1x M8X20ISO4762
  - 4 2x FED0618
  - 5 2x CCBO0803
  - 6 4x M8X55ISO4762
  - 7 2x M5X8ISO7380
  - 9 2x CCD004
  - 10 2x M5X12ISO7380
- kg ~1,6

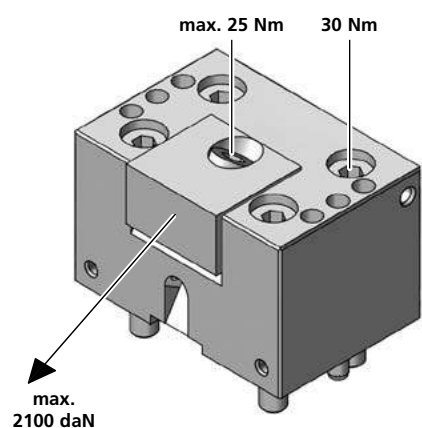

Bestellbeispiel / Ordering example: 1xVS1R80N50-60 & 1x B61

	B58	B60	B61	B62	B62HM	B65	B66	B67	B68	B69	B77	B79F	B79R
C	35	35	35	35	35	35	35	35	35	35	35	35	35
H	20	20	20	20	20	20	20	20	20	25	20	20	20
L	26	19	19	19	19	19	19	24	26	22	22	25	25
D	9	9	9	9	9	9	9	9	9	9	9	9	9
ø	12	12	12	12	12	12	12	12	12	12	12	12	12
i	ALU	56HRC	56HRC	*	HM	HV700	HV700	HV700	*	*	56HRC	HV700	HV700
		x0,2mm	x0,2mm			x0,2mm	x0,2mm	x0,2mm				x0,2mm	x0,2mm
kg	~0,07	~0,12	~0,12	~0,12	~0,12	~0,12	~0,12	~0,14	~0,15	~0,15	~0,12	~0,18	~0,18

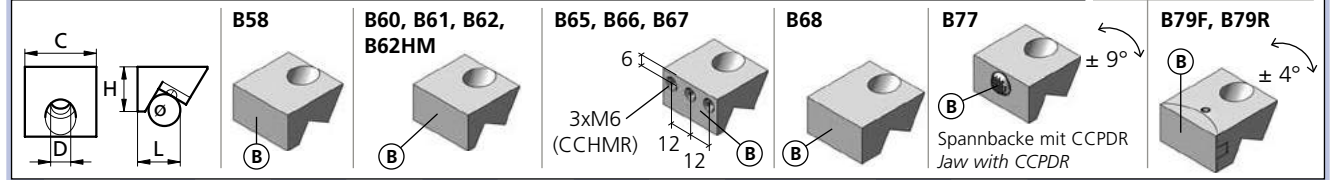
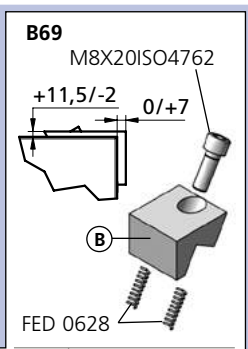

Separat bestellen / Separate order



# VS1R/F125N49-95

microCLAMP

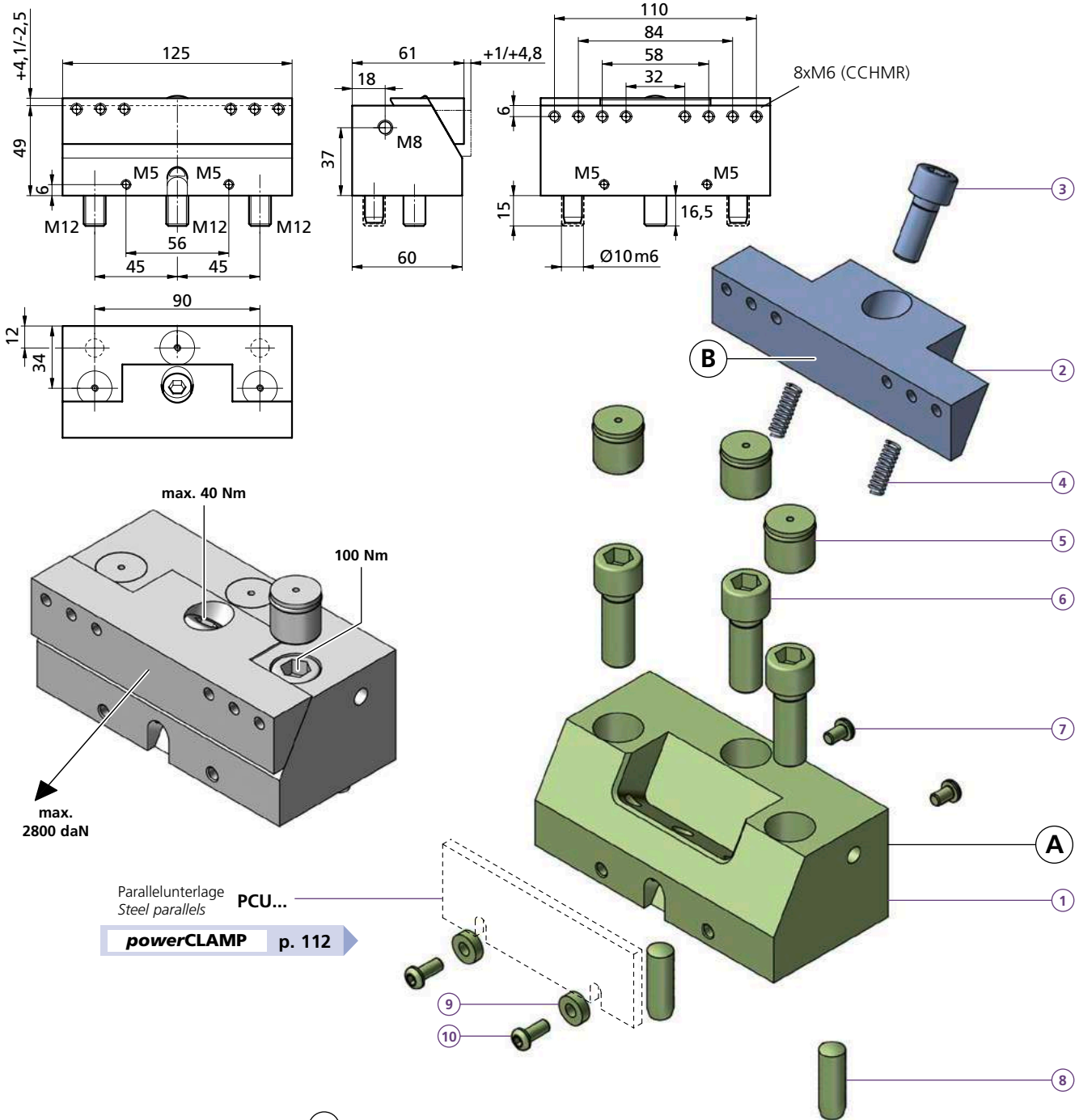

Bestellbeispiel / Ordering example: 1x VS1R125N49-95 & 1x B96

	B95	B96	B97	B98	B99
<b>VS1F125N49-95</b>					
① 1x TF140738					
<b>VS1R125N49-95</b>					
① 1x TF140739					
② 1x					
③ 1x M10X25ISO4762					
④ 2x FED0618					
⑤ 3x PCPF16L18Alu					
⑥ 3x M12X35ISO4762					
⑦ 3x M5X8ISO7380					
⑧ 2x 10m6x30 DIN6325					
⑨ 2x CCD004					
⑩ 2x M5X12ISO7380					
kg	~2,6				

	B95	B96	B97	B98	B99
ⓐ	125	125	125	125	125
ⓑ	25	25	25	25	25
ⓒ	23	23	23	30	23
ⓓ	11	11	11	11	11
ⓔ	15	15	15	15	15
ⓖ	HV700	HV700	*	*	HV700
	x0,2mm	x0,2mm			x0,2mm
kg	~0,45	~0,45	~0,45	~0,63	~0,45

**B95, B96, B97, B99**

**B98**

Separat bestellen / Separate order

\* = weicher Stahl / soft steel



# VS2R80N30-60

microCLAMP

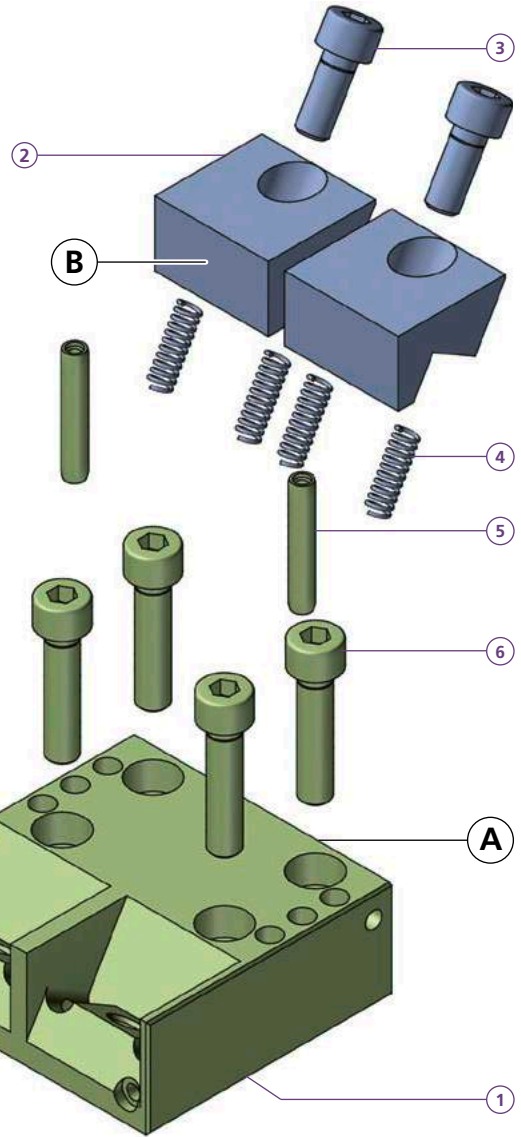
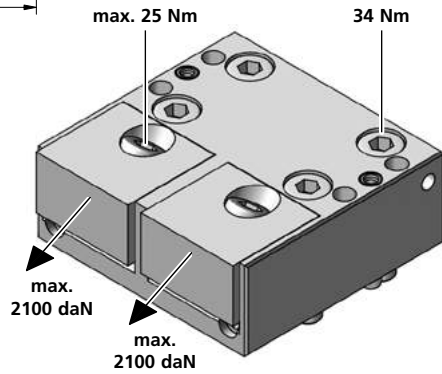
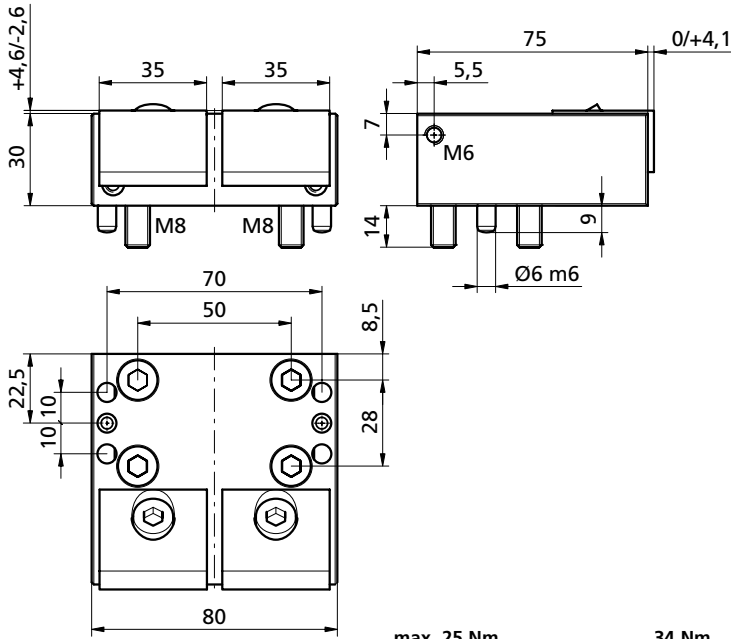

VS2R80N30-60	
1	1x TF140740
2	2x
3	2x M8X20ISO4762
4	4x FED0618
5	2x CCBO0801
6	4x M8X35ISO4762
kg	~1,3

Bestellbeispiel / Ordering example: 1x VS2R80N30-60 & 2x B61

	B58	B60	B61	B62	B62HM	B65	B66	B67	B68	B69	B77	B79F	B79R
C	35	35	35	35	35	35	35	35	35	35	35	35	35
H	20	20	20	20	20	20	20	20	20	25	20	20	20
L	26	19	19	19	19	19	19	24	26	22	22	25	25
D	9	9	9	9	9	9	9	9	9	9	9	9	9
ø	12	12	12	12	12	12	12	12	12	12	12	12	12
i	ALU	56HRC	56HRC	*	HM	HV700	HV700	HV700	*	*	56HRC	HV700	HV700
						x0,2mm	x0,2mm	x0,2mm				x0,2mm	x0,2mm
kg	~0,07	~0,12	~0,12	~0,12	~0,12	~0,12	~0,12	~0,14	~0,15	~0,15	~0,12	~0,18	~0,18

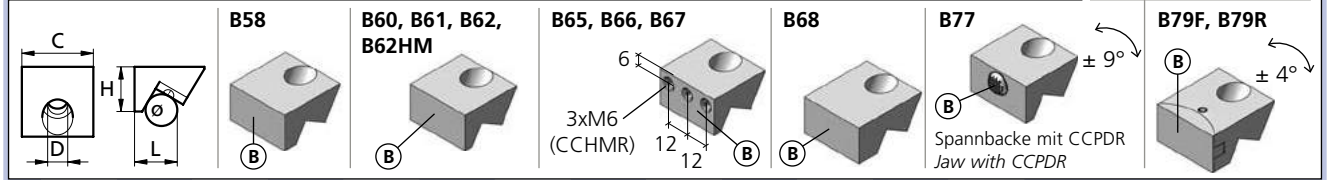
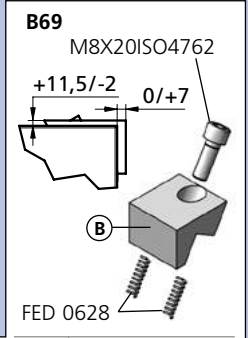





# VS2F90N30-60

microCLAMP

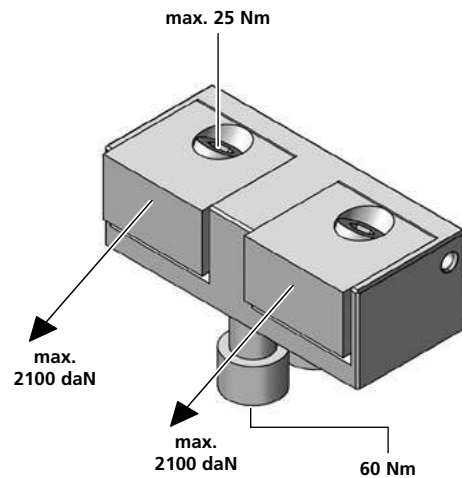
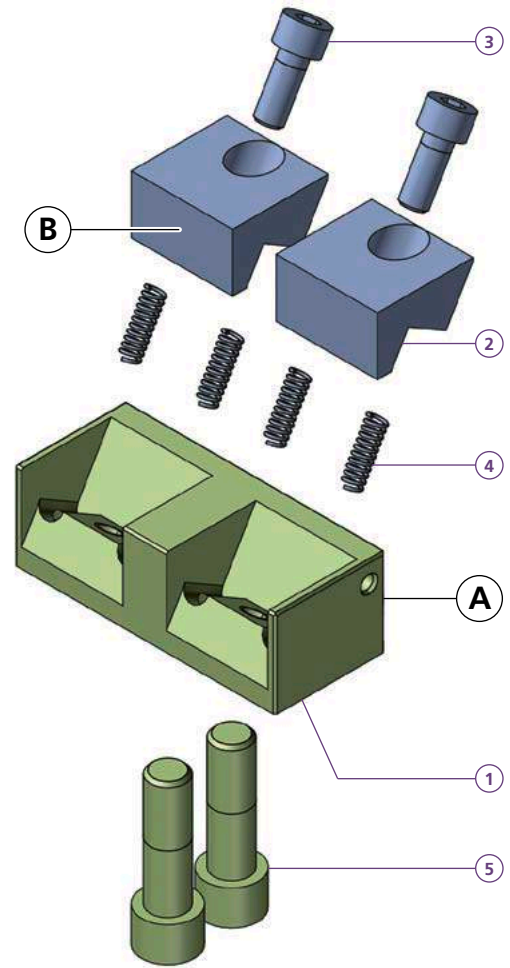
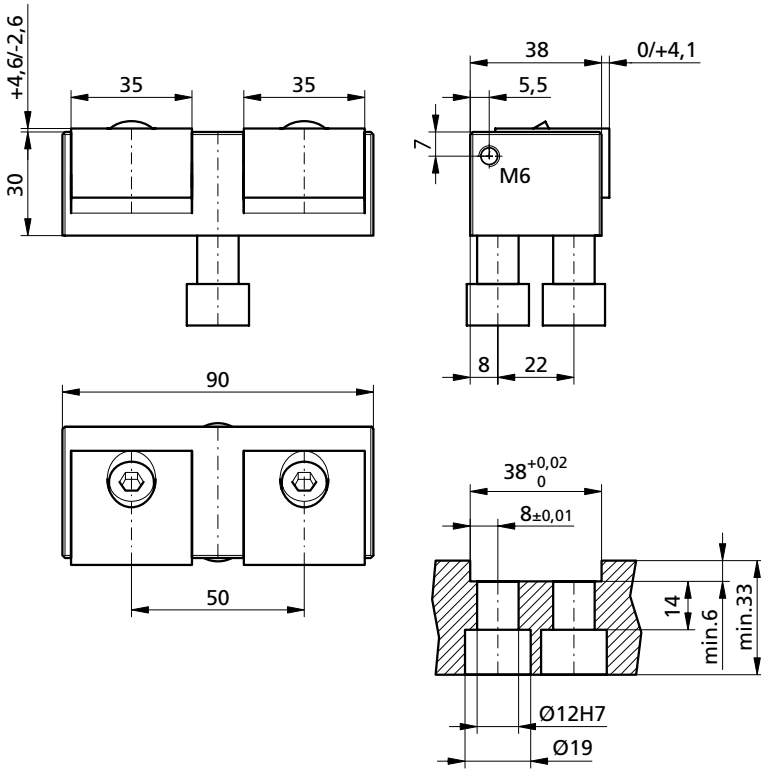

VS2F90N30-60	
1	1x TF140741
2	2x
3	2x M8X20ISO4762
4	4x FED0618
5	2x TWPAS1232
kg	~0,85

Bestellbeispiel / Ordering example: 1x VS2F90N30-60 & 2x B61

	B58	B60	B61	B62	B62HM	B65	B66	B67	B68	B69	B77	B79F	B79R
C	35	35	35	35	35	35	35	35	35	35	35	35	35
H	20	20	20	20	20	20	20	20	20	25	20	20	20
L	26	19	19	19	19	19	19	24	26	22	22	25	25
D	9	9	9	9	9	9	9	9	9	9	9	9	9
o	12	12	12	12	12	12	12	12	12	12	12	12	12
i	ALU	56HRC	56HRC	*	HM	HV700	HV700	HV700	*	*	56HRC	HV700	HV700
						x0,2mm	x0,2mm	x0,2mm				x0,2mm	x0,2mm
kg	~0,07	~0,12	~0,12	~0,12	~0,12	~0,12	~0,12	~0,14	~0,15	~0,15	~0,12	~0,18	~0,18

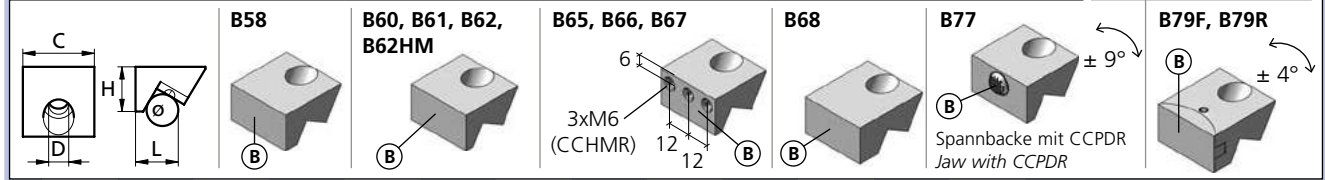
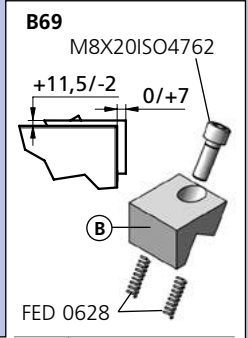

\* = weicher Stahl / soft steel      HM = Hartmetallbeschichtet / Carbide coated      ALU = ENAW-7022

Separat bestellen / Separate order

**MS1R/F35L14-152**

**\*MS1R/F35L14-150\* (Alte Version / Old Version)**

**microCLAMP**

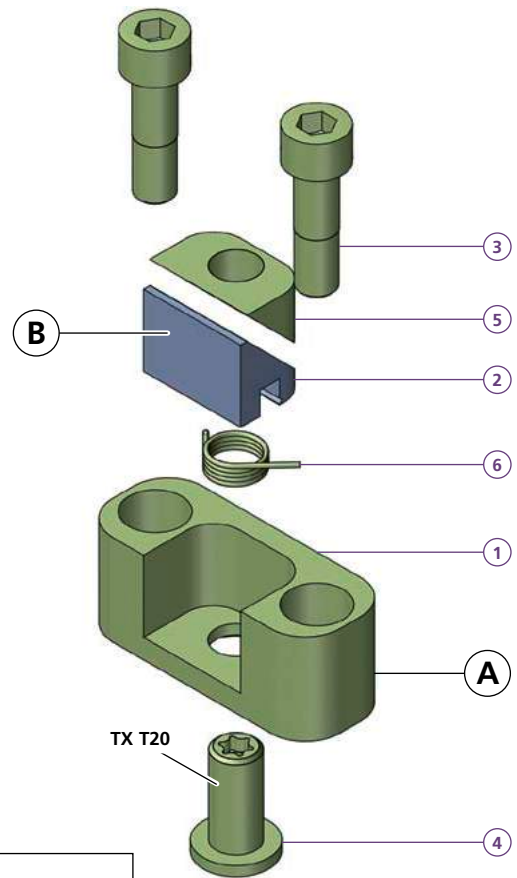
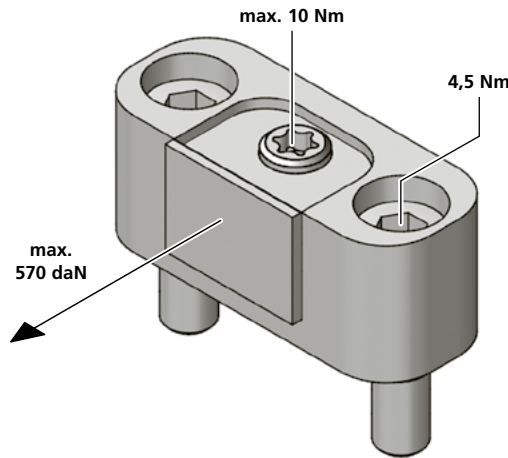
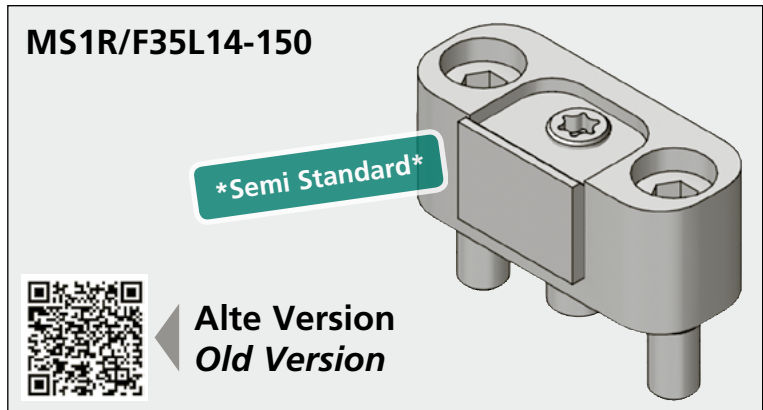
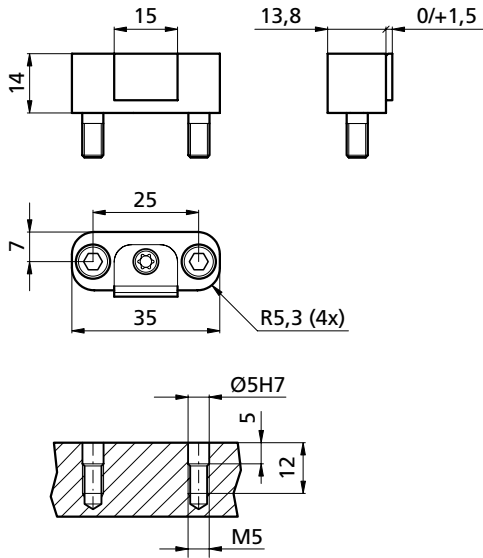

Drehmoment Torque		Spannkraft Workholding force		
Nm	(lb-ft)	~daN	~(lb)	~t
7	5,18	= 390	860	0,39
8	5,92	= 450	990	0,45
9	6,66	= 510	1120	0,51
10	7,4	= 570	1250	0,57

**Achtung:** Bei Spannkraften über 400 daN (0,4t) muss das Spannmodul in eine Nut eingelassen werden (Nuttiefe mindestens 1mm)

**Remark:** Using forces higher than 400 daN, clamps must be mounted into a slot (depth minimum 1mm)

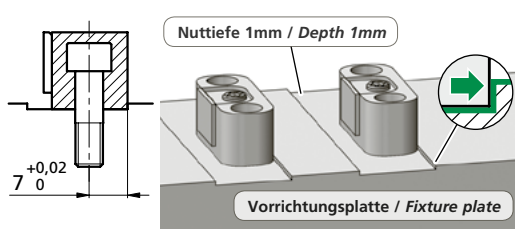

MS1F35L14-152	
1	1x TK181266
MS1R35L14-152	
1	1x TF190596
2	1x
3	2x MS50
4	1x GEWST6L14
5	1x MSK15W45
6	1x SFED6W90
kg	~0,03

Bestellbeispiel / Ordering example: 1x MS1F35L14-152 & 1x B151

	B150	B151
C	15	15
H	11	11
L	40,3	40,3
ø	40	40
i	HV700	HV700
	x0,2mm	x0,2mm
kg	~0,004	~0,004

Separat bestellen / Separate order

VS1R26L35-31

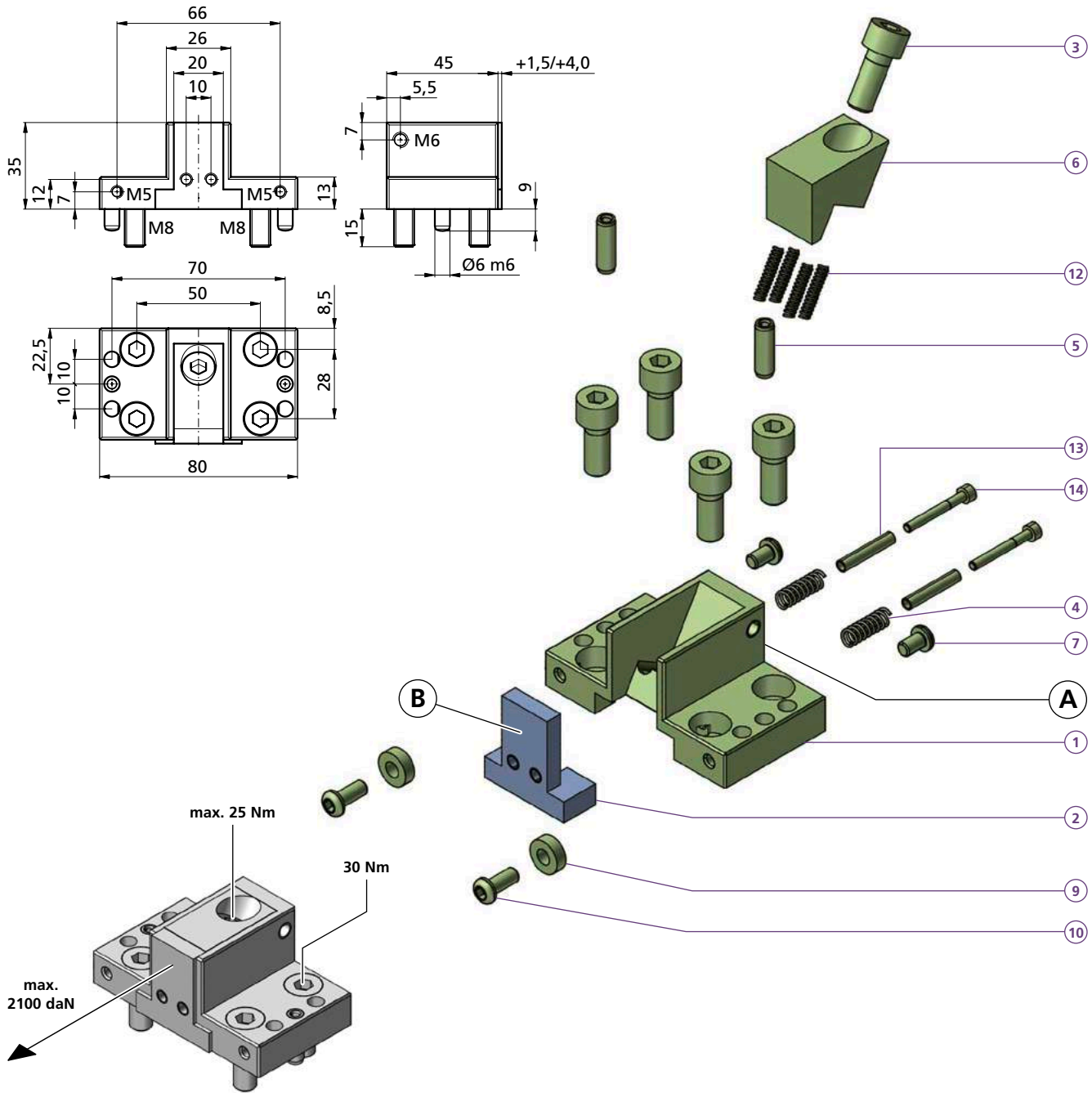

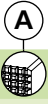
VS1R26L35-31 	
1	1x TF140724
2	1x
3	5x M8X20ISO4762
4	2x FED0618
5	2x CCBO0802
6	1x B30
7	2x M5X8ISO7380
9	2x CCD004
10	2x M5X12ISO7380
12	4x FED0418
13	2x CCD422
14	2x M3X25ISO4762
kg	~0,55

Bestellbeispiel / Ordering example: 1x VS1R26L35-31 & 1x B32

	B31	B32	B33
C	20	20	20
H	35	35	35
L	6	6	6
D	-	-	-
e	-	-	-
i	HV700	HV700	*
	x0,2mm	x0,2mm	
kg	~0,046	~0,046	~0,046

**B31, B32, B33**

\* = weicher Stahl / soft steel

Separat bestellen / Separate order

VS1R/F41L30-51

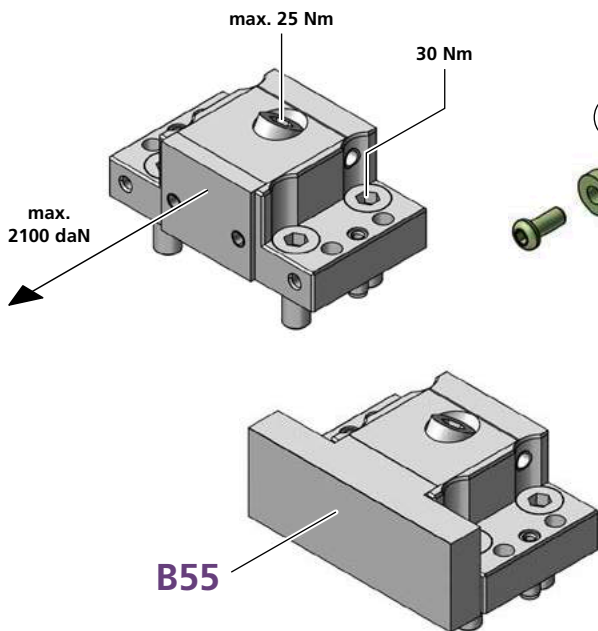
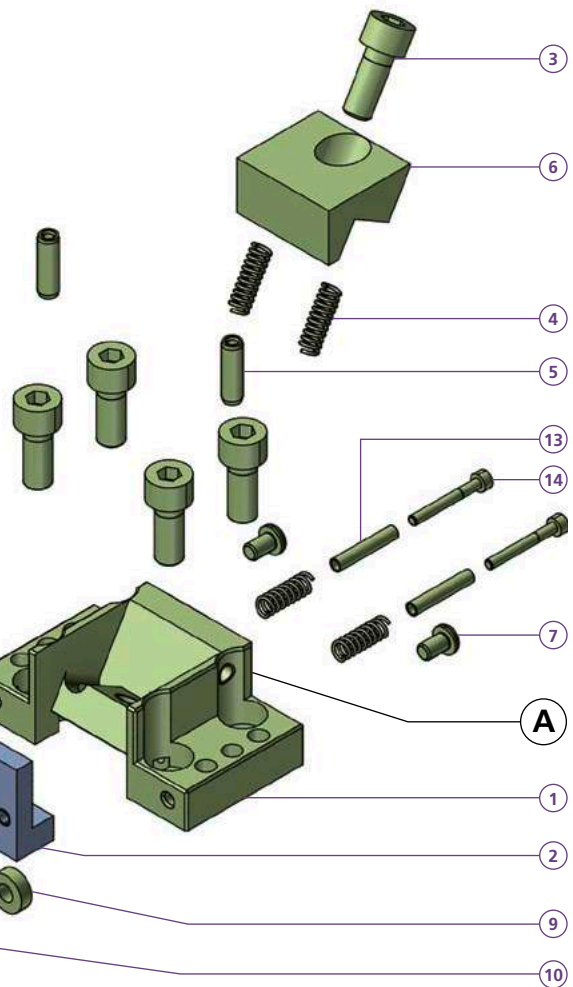
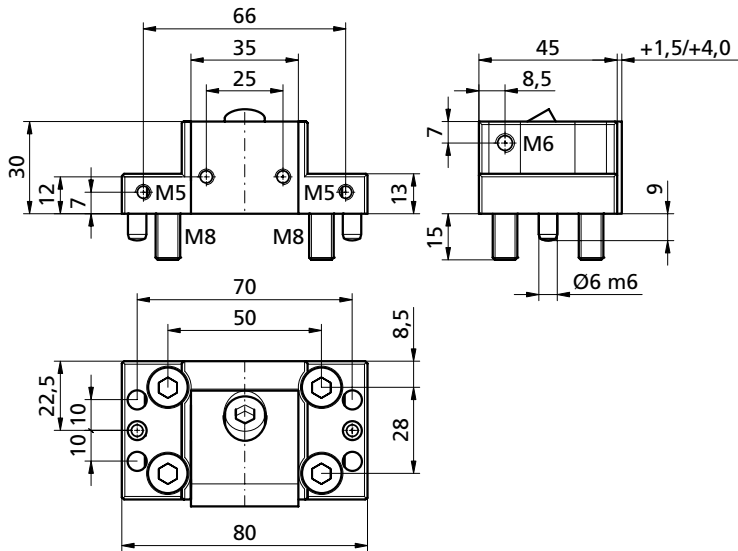

VS1F41L30-51	
1	1x TF140727
VS1R41L30-51	
1	1x TF140728
2	1x
3	5x M8X20ISO4762
4	4x FED0618
5	2x CCBO0802
6	1x B78
7	2x M5X8ISO7380
9	2x CCD004
10	2x M5X12ISO7380
13	2x CCD422
14	2x M3X25ISO4762
kg	~0,545

Bestellbeispiel / Ordering example: 1x VS1R41L30-51 & 1x B52

	B51	B52	B53	B54	B55
C	35	35	35	35	80
H	30	30	30	35	30
L	6	6	10	10	11,5
D	-	-	-	-	-
e	-	-	-	-	-
i	56HRC	56HRC	*	*	*
kg	~0,06	~0,06	~0,06	~0,12	~0,27

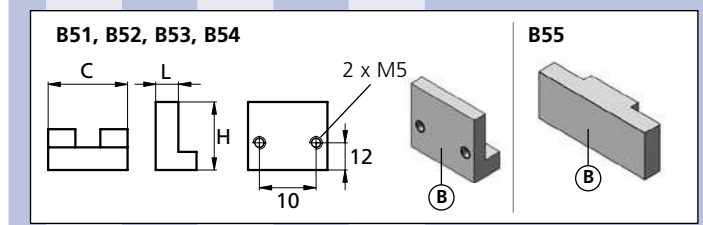

**Vorrichtungsbau Modul für Linearbacken**

Alle bestehenden Linearbacken passen auf dieses Modul  
(**powerCLAMP** Seite **84 - 83**). In die Vorrichtungsplatte wird eine Tasche gefräst um das Modul zu positionieren. Gut geeignet sind die Anschlagbacken **MAND** und **MANF** um als Gegenbacke zu dienen.

**Fixture clamp module for linear jaws**

All of our standard linear jaws fit to this clamp module  
(**powerCLAMP** Page **84 - 83**). All to do is milling a pocket to fit and positioning the clamp modules. To use the **MAND** and **MANF** as datum stop will make a perfect match. (Seite / Page **175 - 176**)

**Fertigungsmasse für die Vorrichtungsplatte**  
**Machining data for the fixture plate**

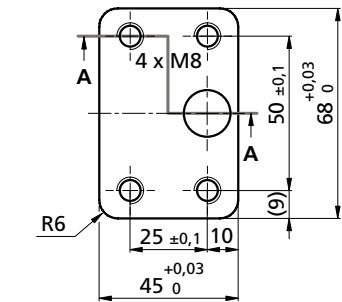

**Schnitt / Section A-A**

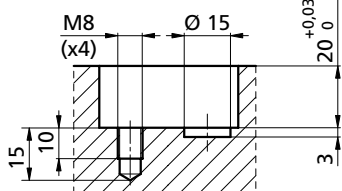

Das Fertigungsmass gilt auch für das Anschlagmodul.  
The production dimension is also valid for the end module. (VA168-20PRG)

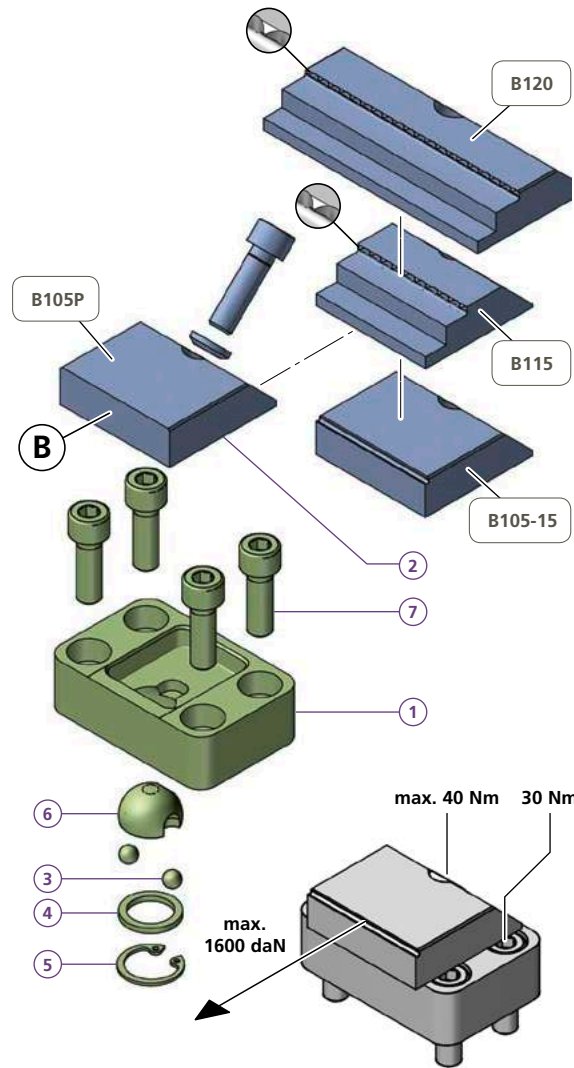
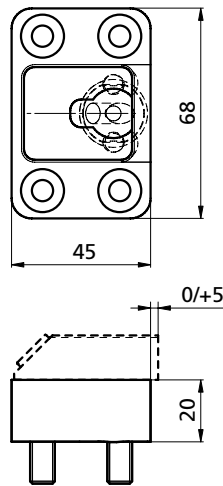

VS1X68L20-105	
1	1x TB150170
2	1x <b>powerCLAMP</b> p. 84, 82, 83
3	1x D=6 DIN 5401
4	1x TN100747
5	1x TN100779
6	1x PCKMR45M8
7	4x M8X25ISO4762
kg	~0,42

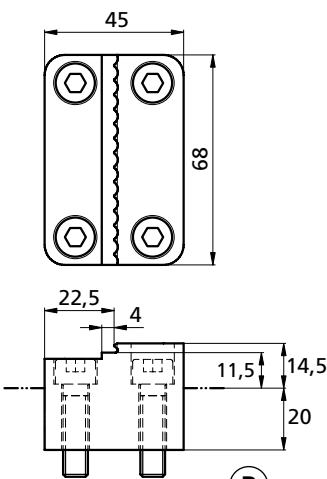

VA168-20PRG	
8	1x TH160280
9	4x M8X30ISO4762
kg	~0,75

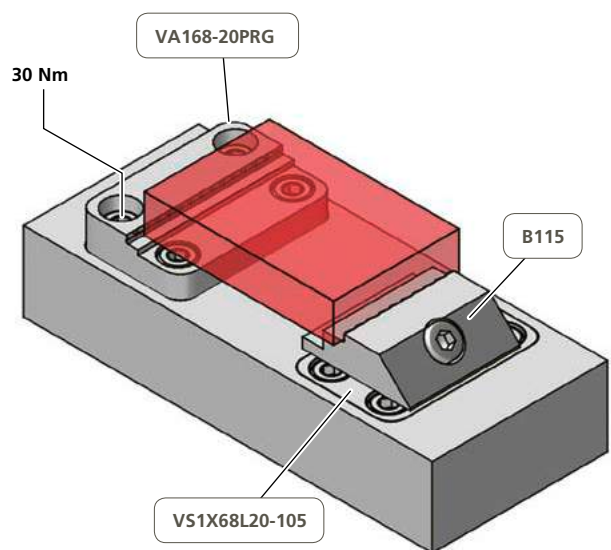
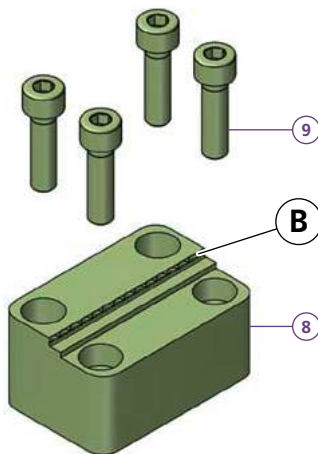



Bestellbeispiel / Ordering example: 1x VS1X68L20-105 & 1x B105P

Separat bestellen / Separate order

**VS1F48L50-105**

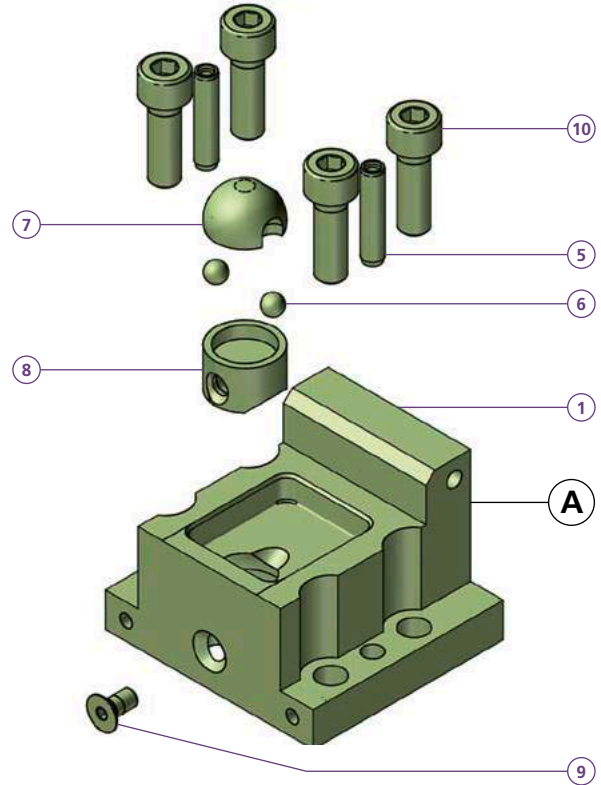
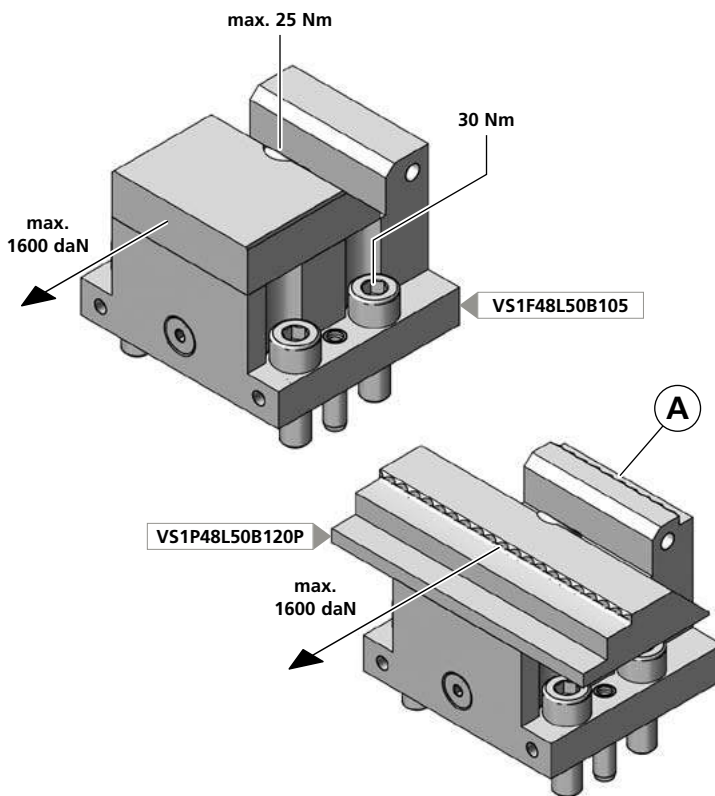
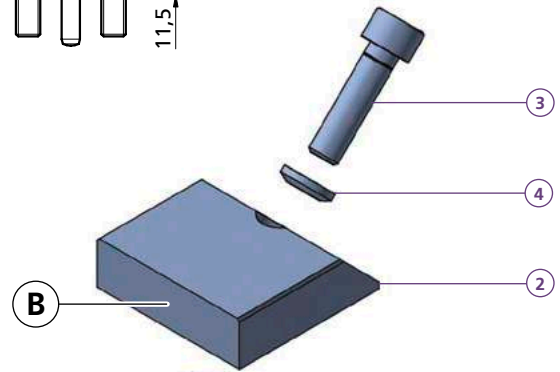
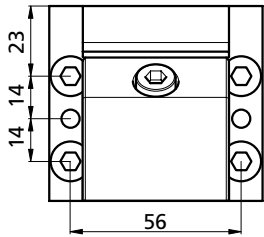
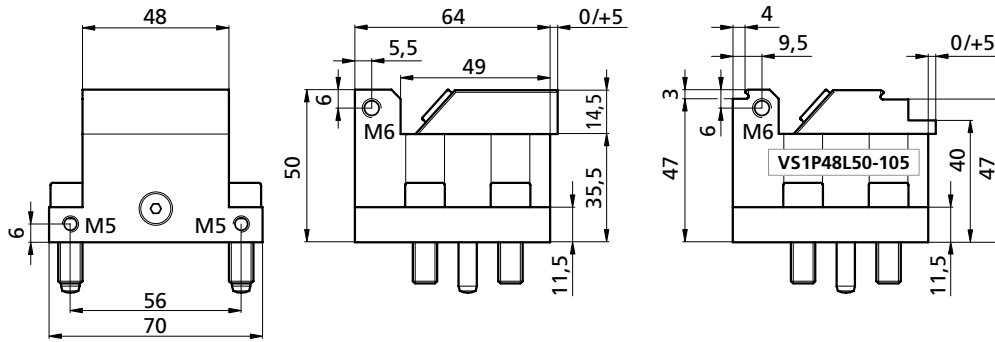
**VS1P48L50-105**



	<b>VS1F48L50-105</b>	
1	1x TK120807	
	<b>VS1P48L50-105</b>	
1	1x TK120761	
2	1x <b>powerCLAMP</b>	
3	1x <b>M8X30ISO4762</b>	
4	1x PCUSR14	
5	1x 6-m6x26 DIN 79790	
6	2x BN869d=6	
7	1x PCKMR45M8	
8	2x TS120001-04	
9	1x M5X10DIN7991	
10	4x <b>M8X25ISO4762</b>	
kg	~1,21	

**powerCLAMP** p. 84

Bestellbeispiel / Ordering example: 1x VS1F48L50-105 & 1x B105

Separat bestellen / Separate order

VS1R/F80L30-51

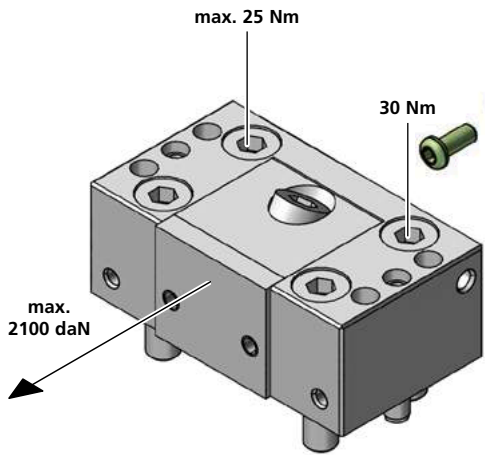
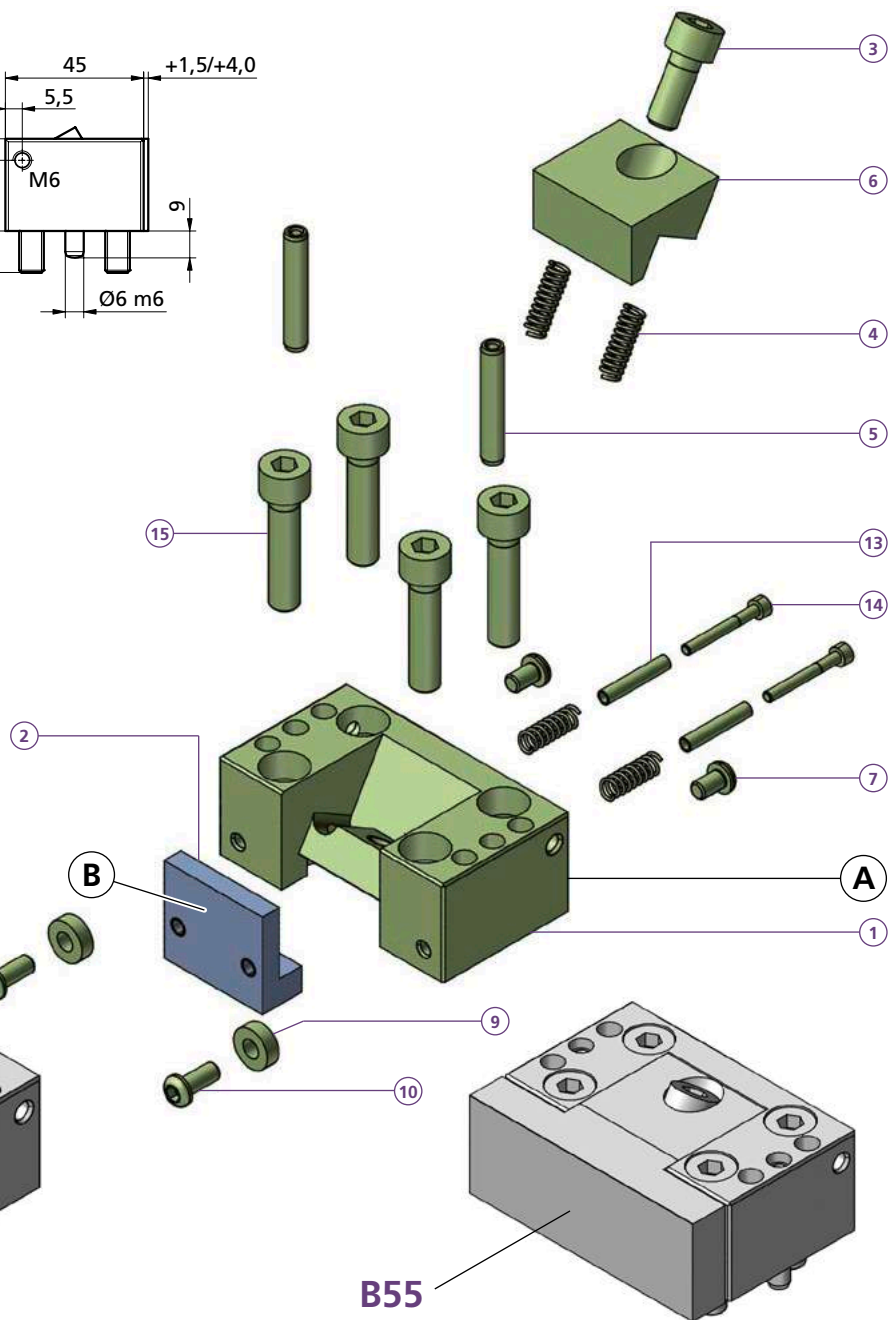
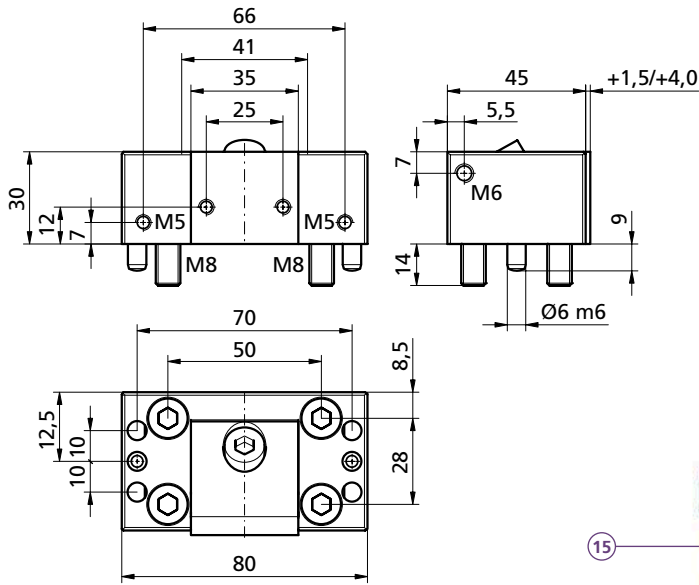

- VS1F80L30-51**
- 1 1x TF140731
- VS1R80L30-51**
- 1 1x TF140732
  - 2 1x
  - 3 1x M8X20ISO4762
  - 4 4x FED0618
  - 5 2x CCBO0801
  - 6 1x B78
  - 7 2x M5X8ISO7380
  - 9 2x CCD004
  - 10 2x M5X12ISO7380
  - 13 2x CCD422
  - 14 2x M3X25ISO4762
  - 15 4x M8X35ISO4762
- kg ~0,74

Bestellbeispiel / Ordering example: 1x VS1R80L30-51 & 1x B52

	B51	B52	B53	B54	B55
C	35	35	35	35	80
H	30	30	30	35	30
L	6	6	10	10	11,5
D	-	-	-	-	-
e	-	-	-	-	-
i	56HRC	56HRC	*	*	*
kg	~0,06	~0,06	~0,06	~0,12	~0,27

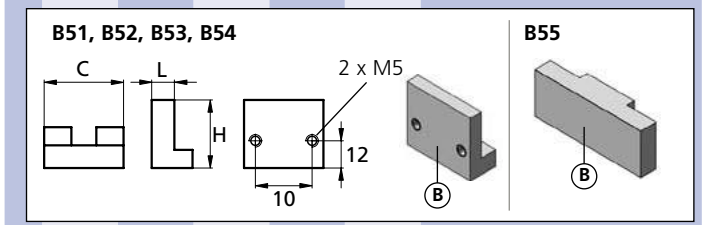

\* = weicher Stahl / soft steel

Separat bestellen / Separate order

**VS1X59L60K**

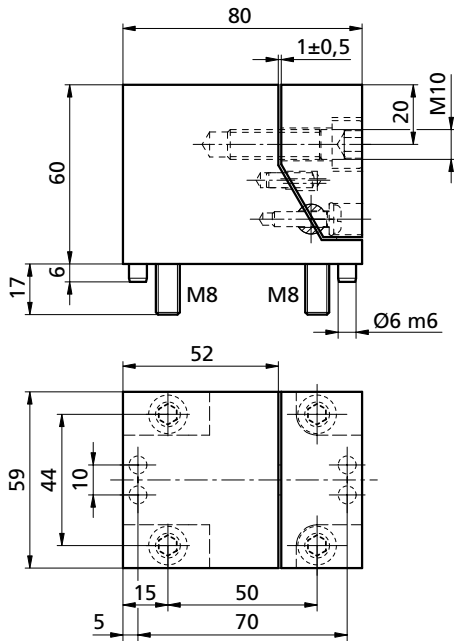

Empfohlener Sechskantschlüssel  
Recommended hexagon wrench  
**PB2212L/6**

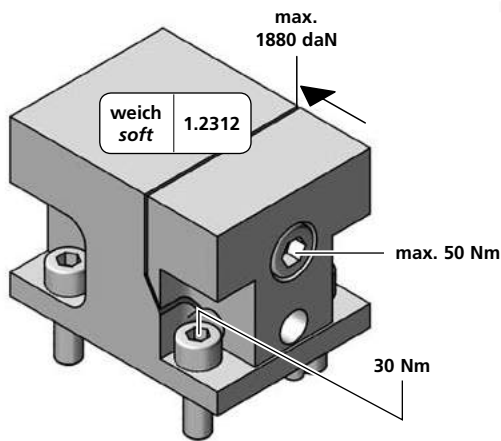
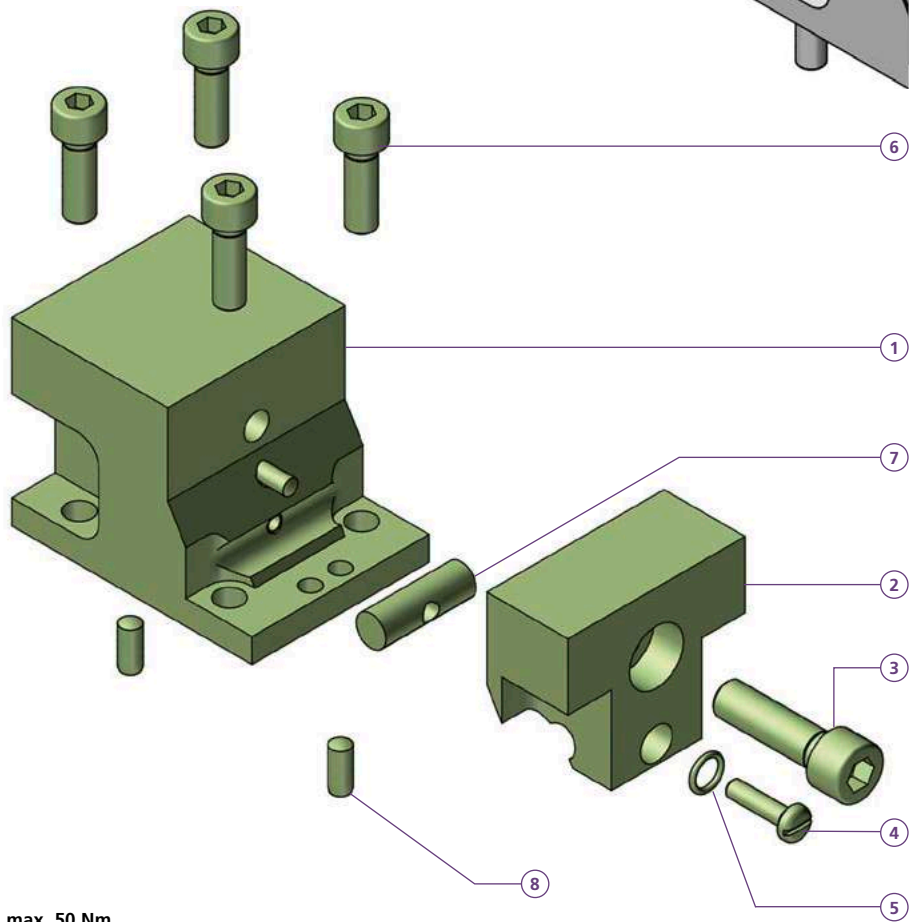

Spannstelle an Werkstück angepasst und nitriert.  
Clamping face machined to the shape of the workpiece and nitrided.

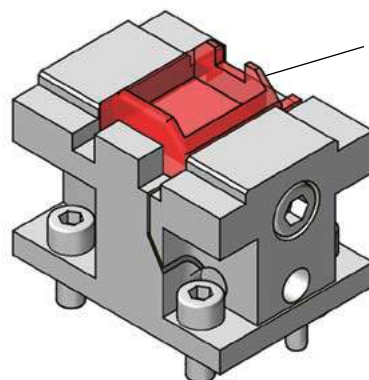

*VS1X59L60K	
1	1x VS1X59L60H5KA
2	1x VS1X59L60H5KS
3	1x M10X35ISO4762
4	1x M5X20DIN85A
5	1x ORØ8x1,5
6	4x <b>M8X25ISO4762</b>
7	1x VS1X59L60H5KG
8	2x 6m6x14 DIN 6325
kg	~1,89



VS1X59L60H5

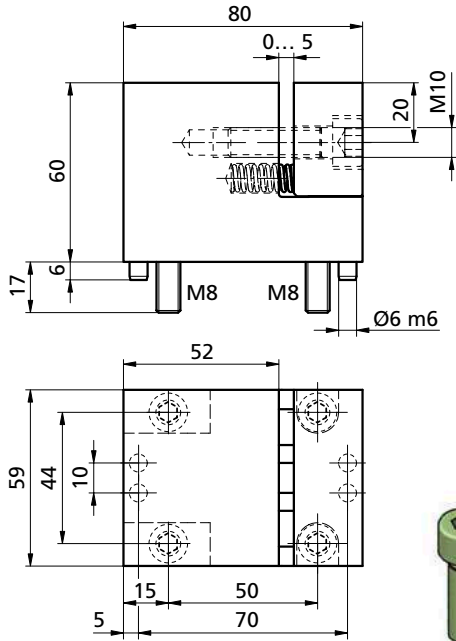

Empfohlener Sechskantschlüssel  
Recommended hexagon wrench  
**PB2212L/6**

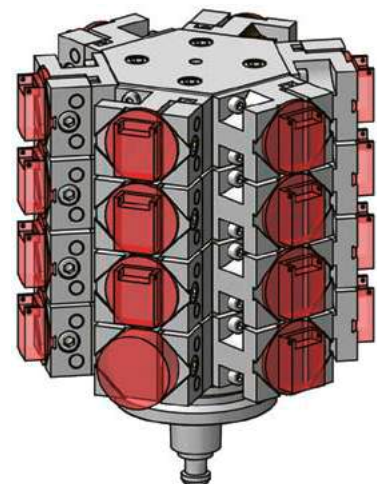
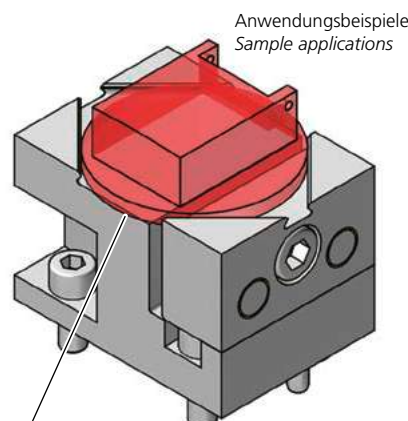
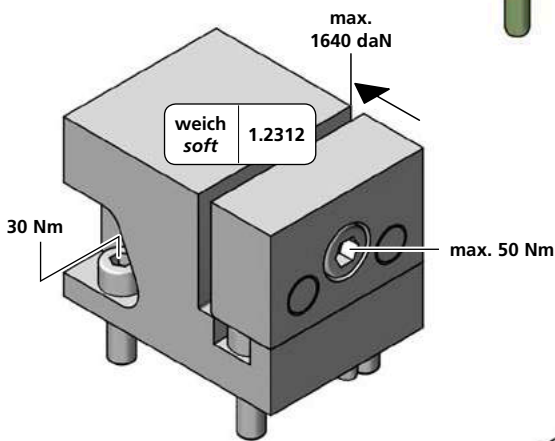
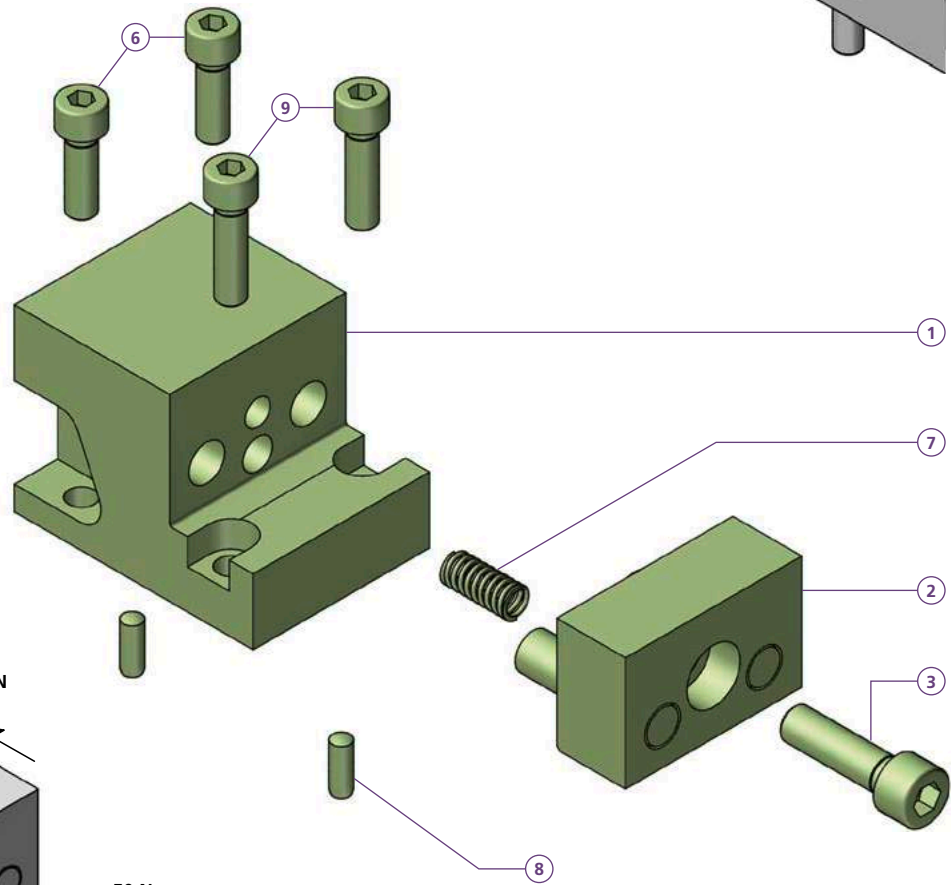
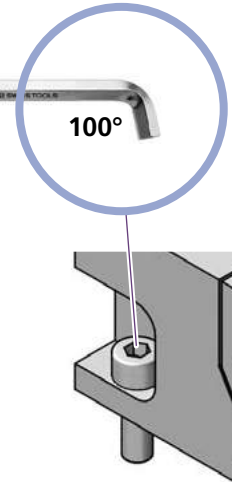

Spannstelle an Werkstück angepasst und nitriert.  
Clamping face machined to the shape of the workpiece and nitrided.

*VS1X59L60H5	
1	1x VS1X59L60H5A
2	1x VS1X59L60H5S
3	1x M10X35ISO4762
6	2x M8X25ISO4762
7	1x FED0833
8	2x 6m6x14 DIN 6325
9	2x M8X30ISO4762
kg	~1,94

\* = Stahl / steel 1.2312



Bestellbeispiel / Ordering example : VS1X59L60H5

Separat bestellen / Separate order

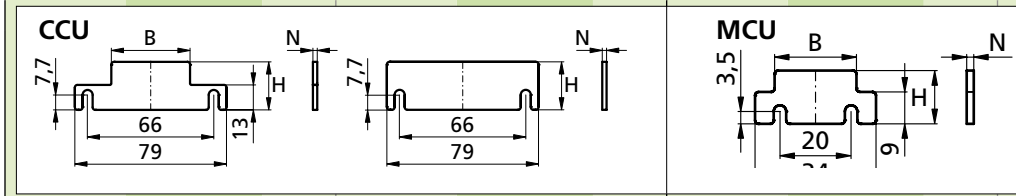

durchgehärtet / through hardened										nitriert / nitrated									
<b>26mm</b>	<b>B</b>	<b>H</b>	<b>N</b>	<b>kg</b>	<b>41mm</b>	<b>B</b>	<b>H</b>	<b>N</b>	<b>kg</b>	<b>23mm</b>	<b>B</b>	<b>H</b>	<b>N</b>	<b>kg</b>	<b>41mm</b>	<b>B</b>	<b>H</b>	<b>N</b>	<b>kg</b>
CCU15026	26	15	2,2	~0,017	CCU15081	41	15	2,2	~0,018	MCU11037	23	11	2	~0,004	CCU15083	41	15	3	~0,025
CCU20026	26	20	2,2	~0,02	CCU20081	41	20	2,2	~0,022	MCU15037	23	15	2	~0,006	CCU20083	41	20	3	~0,029
CCU25026	26	25	2,2	~0,022	CCU25081	41	25	2,2	~0,025	MCU18037	23	18	2	~0,008	CCU25083	41	25	3	~0,034
CCU30026	26	30	2,2	~0,025	CCU27581	41	27	2,2	~0,027	MCU20037	23	20	2	~0,008	CCU27583	41	27,5	3	~0,036
CCU32526	26	32,5	2,2	~0,026	CCU30081	41	30	2,2	~0,029	MCU22537	23	22,5	2	~0,008					
<b>38mm</b>	<b>B</b>	<b>H</b>	<b>N</b>	<b>kg</b>	<b>80mm</b>	<b>B</b>	<b>H</b>	<b>N</b>	<b>kg</b>	<b>26mm</b>	<b>B</b>	<b>H</b>	<b>N</b>	<b>kg</b>	<b>80mm</b>	<b>B</b>	<b>H</b>	<b>N</b>	<b>kg</b>
CCU30039	38	30	2,2	~0,028	CCU15080	79	15	2,2	~0,019	CCU15027	26	15	3	~0,024	CCU15082	79	15	3	~0,026
CCU35039	38	35	2,2	~0,031	CCU20080	79	20	2,2	~0,027	CCU20027	26	20	3	~0,027	CCU20082	79	20	3	~0,036
CCU40039	38	40	2,2	~0,035	CCU25080	79	25	2,2	~0,035	CCU25027	26	25	3	~0,03	CCU25082	79	25	3	~0,045
CCU45039	38	45	2,2	~0,039	CCU27580	79	27,5	2,2	~0,039	CCU30027	26	30	3	~0,033	CCU27582	79	27,5	3	~0,049
					CCU30080	79	30	2,2	~0,043	CCU32527	26	32,5	3	~0,034					
					CCU35080	79	35	2,2	~0,05										
					CCU40080	79	40	2,2	~0,057										
					CCU45080	79	45	2,2	~0,063										

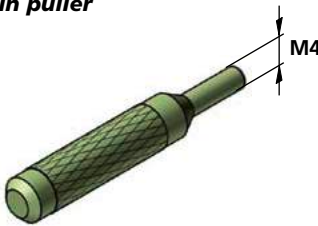

<p><b>Schraubenzieher mit Konterung für</b> <b>Screwdriver with holding sleeve for</b></p>  <p><b>CCBXSK</b></p>	<p><b>Positionsbolzen</b> <b>Position pin</b></p>  <table border="1"> <thead> <tr> <th></th> <th>L</th> <th>kg</th> </tr> </thead> <tbody> <tr> <td>CCBO0801</td> <td>36</td> <td>~0,006</td> </tr> <tr> <td>CCBO0802</td> <td>20</td> <td>~0,002</td> </tr> <tr> <td>CCBO0803</td> <td>50</td> <td>~0,01</td> </tr> </tbody> </table>		L	kg	CCBO0801	36	~0,006	CCBO0802	20	~0,002	CCBO0803	50	~0,01	<p><b>Bolzen-Auszieher</b> <b>Pin puller</b></p>  <p><b>CCAZ1050</b></p>
	L	kg												
CCBO0801	36	~0,006												
CCBO0802	20	~0,002												
CCBO0803	50	~0,01												

**Positionierstift (spreizbar)**  
**Locating pin (expandable)**

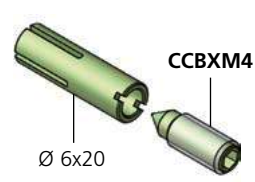

**CCBXM4**  
Ø 6x20

**CCBX0802**

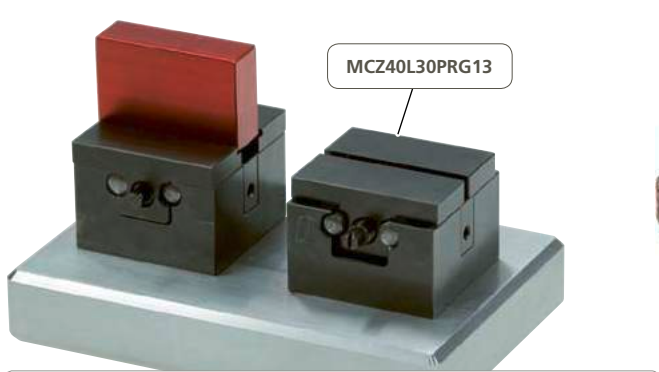

Mehr Informationen siehe Zentrischspanner  
For more information check the self centring vise **p. 116**



Mehr Informationen siehe Zentrischspanner  
For more information check the self centring vise **p. 127**



CC ...  
CC ... V

microCLAMP

**Universalbacke / Universal jaw**

CC	Material	A	B	x	Y	Z	i	kg
CC8011	M5X12ISO7380			30	24	10	56 HRC	~ 0,15
CC8025				50	44	10		~ 0,28
CC8040	M5X20ISO4762			30	24	20	*	~ 0,33

**Backe mit 2 Pendeldruckstücken  
Jaw with 2 swiveling balls**

CC	Material	A	B	x	Y	Z	i	kg
CC8060	M5X20ISO4762			30	24	10	56 HRC	~ 0,30
CC8060R	M3x8ISO4762			50	44	10		~ 0,30

CC	Material	A	B	x	Y	Z	i	kg
CC8021	M5X12ISO7380			30	24	10	56 HRC	~ 0,11
CC8026				50	44	10		~ 0,17
CC8041	M5X20ISO4762			30	24	20	*	~ 0,24

**Backe für Druckstift  
Jaw for pressure pin**

CC	Material	A	x	kg
CC8070	M5X12ISO4762		30	~ 0,17

**Weiche Backe / Soft jaw**

CC	Material	x	i	kg
*CC8030	M5X12ISO4762	30	1.1191	~ 0,35
*CC8050		50		~ 0,59

**Prismabacke / Prismatic jaw**

CC	Material	x	Ø	i	kg
CC8050V120°	M5X25ISO4762	30	min 8 max 120	56 HRC	~ 0,41

CC	Material	x	Ø	i	kg
CC8050V90°	M5X18ISO4762	30	min 6 max 42	56 HRC	~ 0,38

**Backe / Jaw**

CC	Material	A	B	x	kg
CC8210	HV 700x0,2mm			30	~ 0,03
CC8211				30	

CC	Material	A	B	x	kg
CC8220	HV 700x0,2mm			30	~ 0,02
CC8221				30	

\* = weicher Stahl / soft steel

Bestellbeispiel / Ordering example: CC8011



microCLAMP

